

# ELECTRONIC TRANSFORMER FOR A 12V HALOGEN LAMP

by P. Fichera, R. Scollo

## 1. INTRODUCTION

Lighting that uses halogen lamps is commonly found in residential environments, where it offers a warm light in comparison with that generated by fluorescent tubes, and greater efficiency than conventional filament bulbs.

These lamps are available with voltage ratings of 6, 12 or 24 Volts, and so a transformer is needed in order to provide the lamp with a low voltage supply from either 110V a.c. or 220V a.c. mains. They are generally available with power ratings of 50, 75, 100 and 250 Watts.

The “electronic” transformer represents an alternative means of power conversion to the more standard iron core, 50Hz transformer technique.

The advantages of the electronic transformer compared with the classical solution are:

- The output power from the electronic transformer to the lamp can be varied, thus dimming control can be added;

- It is possible to include protection against short circuit of the lamp filament;
- Weight can be reduced and the construction made more compact; and
- Acoustic noise (mains hum) is eliminated.

## 2. THE ELECTRONIC SOLUTION

The topology of the circuit is the classic half-bridge. The control circuit could be realised using an IC (so fixing the operating frequency), but there is a more economical solution which consists of a self-oscillating circuit where the two transistors are driven in opposing phase by feedback from the output circuit.

## 3. CIRCUIT DESCRIPTION

The line voltage is rectified by the full-bridge rectifier, generating a semi-sinusoidal voltage at double the line frequency. The diac starts to conduct during each cycle, starting the half-bridge oscillation. The turn-on of the diac can be varied by modifying the time constant of the RC network formed by R and

Figure 1. Electronic transformer for 12V Halogen Lamp

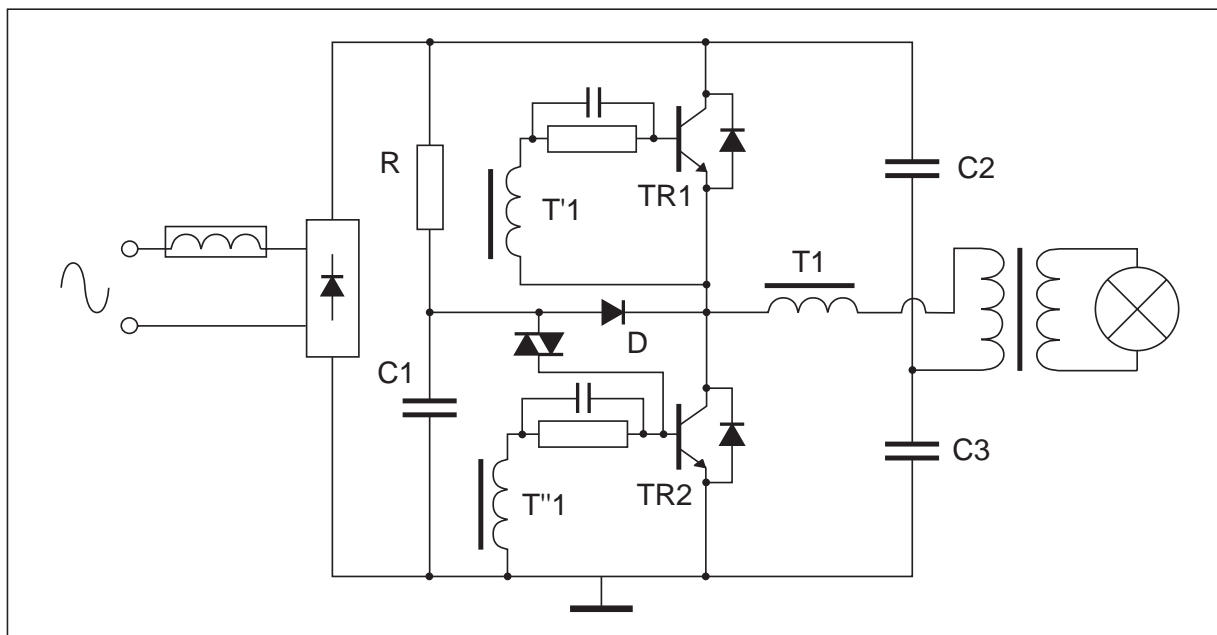



exists, the protection will be re-triggered after a short time. In this way the circuit limits the energy dissipated by the transistors.

It should be noted that the transistor must be robust enough to withstand the fault condition while the short circuit protection reacts - that is to say devices with a large RBSOA must be used.

#### 4. TRANSISTOR SELECTION

Because of the tight cost constraints and the voltage range of this application, the bipolar is the usual choice of transistor. The voltage and current ratings of the power devices used must be selected based on the circuit topology, the required output power and the frequency of operation.

##### 4.1 Voltage rating

The required voltage rating of the devices is defined by the half-bridge topology. Supplying the circuit with 220V RMS A.C. mains, calculating peak value, and adding a safety margin, gives a maximum supply voltage  $V_{CC}$  of:

$$\begin{aligned} V_{CC(\max)} &= 220V \times \sqrt{2} + 10\% \\ &= 310V + 10\%. \\ &\approx \mathbf{350V.} \end{aligned}$$

To this figure must also be added the overvoltage generated by the input filter at turn-off. In practice, devices are used with a rating of:

$$V_{CE(\max)} = \mathbf{450 - 500V}$$

##### 4.2 Current rating

The nature of the half-bridge topology is such that in normal operation, half the supply voltage is dropped across each device, so from the above figures  $V_{CE}$  in the steady state is  $310V / 2$ , 155V. Hence the collector current in the steady state can be calculated using:

$$\begin{aligned} P_{OUT} &= I_{C(RMS)} \cdot V_{CE(RMS)} \\ V_{CE(RMS)} &= 1/2 \cdot V_{mains} \\ I_{C(RMS)} &= \frac{2 \cdot P_{OUT}}{V_{mains}} \\ I_{C(RMS)} &= \frac{I_{C(peak)}}{\sqrt{2}} \\ I_{C(peak)} &= \frac{2 \cdot \sqrt{2} \cdot P_{OUT}}{V_{mains}} \\ &= \frac{2 \cdot \sqrt{2} \cdot 50W}{220V} \end{aligned}$$

$$I_{C(peak)} = \mathbf{0.64A}$$

As stated above, when the circuit is first turned on, the low initial resistance the lamp filament causes a large current to flow through the transistors. This current can be up to ten times the current in the steady state, and the devices must be selected to withstand this.

In this example then it is recommended that the device used is bipolar transistor, rated at 450V and around 7A. An example is the BUL38-D, which also incorporates an integrated anti-parallel diode.

##### 4.3 Storage and fall times

The fall time,  $t_{fall}$ , of the transistors influences the losses of the circuit, while the storage time,  $t_s$ , is important as it affects the switching frequency of the converter. The nature of the processes used to produce bipolar transistors means that the storage time between batches of transistors may vary considerably. The transistors used must be manufactured, tested and selected to have storage times within certain limits.

Transistors with too large a storage time may cause the circuit to oscillate below the operating limits of the output transformer, causing saturation of the core towards the end of each cycle. This will cause a spike in the collector current of the transistors every cycle, which will eventually cause them to overheat and be destroyed.

#### 5. POWER FACTOR CORRECTION

As the capacitor at the input of the circuit is relatively small, there is little deformation of the input current waveform. However, this type of circuit generates a certain amount of electro-magnetic interference, due to the high frequency source that feeds the resonant network, and so a suitable filter must be inserted in the circuit before the rectifier bridge to prevent this interference being fed back to the mains. This filter must satisfy VDS and UL norms concerning maximum RFI levels, clearance and creepage distances and the frequency response of the filter.

#### CONCLUSION

Electronic transformers can offer an economic, simple and compact alternative to the traditional 50Hz transformer. This technique is particularly useful in halogen lamp applications because of the short circuit protection, reduced weight, absence of acoustic noise and the possibility of including a dimming facility.

## APPLICATION NOTE

---

The simple general circuit shown and the guidance given in choosing a suitable transistor should provide a useful starting point for developing more specific applications.

### Electronic Transformer Design-in Guidelines

Type	V <sub>cew</sub> (V)	V <sub>ces</sub> /V <sub>cev</sub> (V)	I <sub>c</sub> (A)	P <sub>tot</sub> (W)	Package	Typical Application
BUL39D*	400	850	4	70	TO-220	up to 50W
BUL38D*	450	800	5	80	TO-220	up to 75W
BUL49D*	450	850	5	80	TO-220	up to 75W
BUL58D*	450	850	8	90	TO-220	up to 105W
BUL59	400	800	8	85	TO-220	up to 105W
BUL67	450	700	10	100	TO-220	up to 150W
BUL510	400	1000	10	100	TO-220	up to 150W
BUL89	450	850	12	110	TO-220	up to 250W
BUL810	450	1000	15	125	TO-218	up to 300W

\*Integrated freewheeling diode

Information furnished is believed to be accurate and reliable. However, STMicroelectronics assumes no responsibility for the consequences of use of such information nor for any infringement of patents or other rights of third parties which may result from its use. No license is granted by implication or otherwise under any patent or patent rights of STMicroelectronics. Specification mentioned in this publication are subject to change without notice. This publication supersedes and replaces all information previously supplied. STMicroelectronics products are not authorized for use as critical components in life support devices or systems without express written approval of STMicroelectronics.

The ST logo is a trademark of STMicroelectronics

© 1999 STMicroelectronics - Printed in Italy - All Rights Reserved

STMicroelectronics GROUP OF COMPANIES

Australia - Brazil - China - Finland - France - Germany - Hong Kong - India - Italy - Japan - Malaysia - Malta - Morocco - Singapore - Spain - Sweden - Switzerland - United Kingdom - U.S.A.

<http://www.st.com>