

LED display and signage solutions

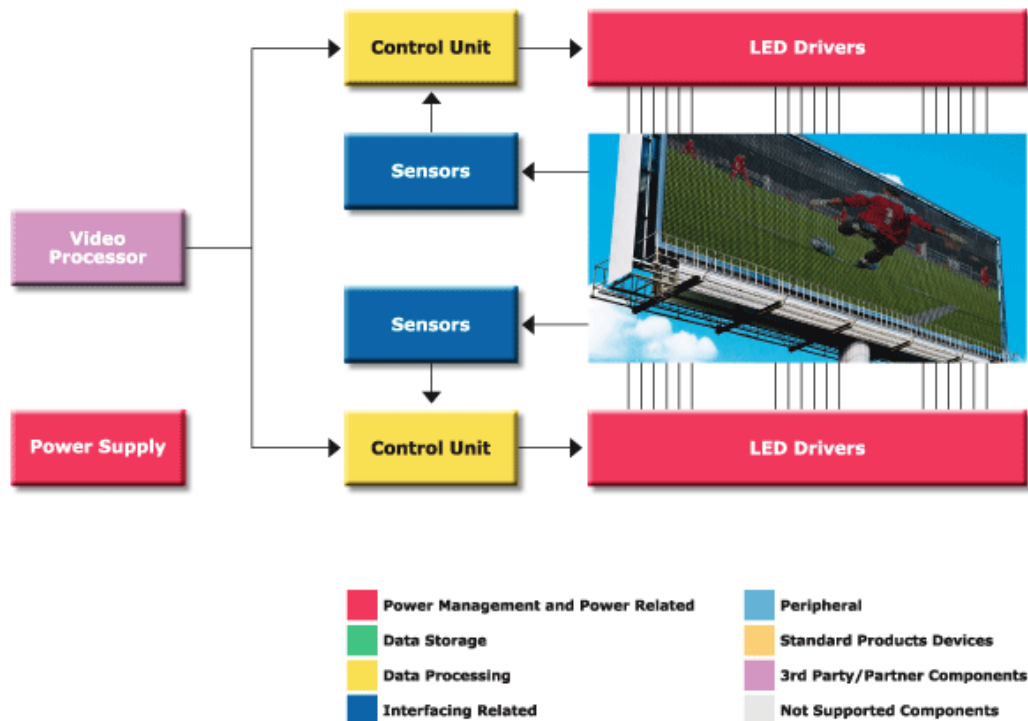

LED display and signage solutions



ST's position

- #1 in lighting segment*
- #2 in power management**

ST's expertise

- System solutions
- Technology integration and innovation
- Excellent technical support

*STMicroelectronics, Datapoint and Darnell - 2008

**iSupply - 2010

- LED display and signage solutions
 - LED array driver features/benefits
 - Constant current
 - Error detection/diagnostics
 - Auto power savings/shutdown
 - High precision
 - High current
 - Balanced turn-on/off
 - System evaluation boards and tools
 - HB LED driver solution with diagnostics (32, 40 LEDs)
 - 16 x 32 LED matrix display panel
 - RGB LED driver for color displays and backlighting
 - Super HB RGB color LED solution
 - High-brightness LED array dimmer solution
 - RGB moving message display system



LED array drivers



From small to very large LED displays and signs

- Full color video
- Monochrome message boards
- Variable message signs
- Transportation
- Information
- Special lighting
- LED backlighting

STP04CM05, STP08*P05,
STP16*05 and STP24*05
families

- Constant-current drivers, set by only one external resistor
- Serial data and clock resynchronization
- High current and high precision
- Thermal shutdown
- Error detection and auto power saving

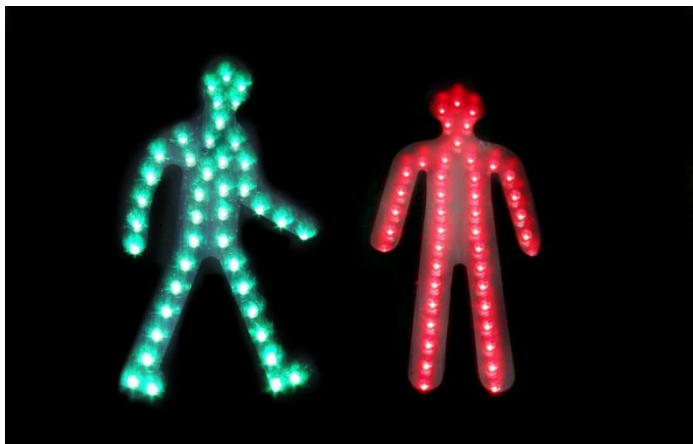

LED array driver general portfolio



STP****05 series features

- Absolute output voltage up to 20 V
- Output enable frequency up to 1 MHz
- SDI and CLK resynchronized device-by-device w/o use of CLK falling edge
- Analog thermal shutdown protection
- Clock frequency over 30 MHz
- TSSOP package with exposed pad
- Extended junction temperature range of -40 to 125 °C

C: Constant current

P: Precision

PP: Precision and lower output current range (3 to 40 mA output current)

M: High current (80 to 400 mA)

D: Error detection/diagnostic

S: Auto shutdown

Part number	Description	I _{OUT}	Bit precision	Chip precision	Evaluation board
STP08CP05	8-bit C.C. LED driver	5 to 100 mA	+/-1%	+/-3%	-
STP08DP05	8-bit C.C. LED driver with diagnostics	5 to 100 mA	+/-1.5%	+/-5%	STEVAL-ILL002V3 STEVAL-ILL002V4
STP16CP(P)(S)05*	16-bit with auto power saving	5 to 100 mA	+/-1.5%	+/-5%	STEVAL-ILL003V2
STP16DP(P)(S)05	16-bit with diagnostics	5 to 100 mA	+/-1.5%	+/-5%	STEVAL-ILL025V1
STP1612PW05	16-bit with 12/16 bit e-PWM	3 to 80 mA	+/-1.5%	+/-6%	STEVAL-ILL028V1
STP04CM05	4-bit CC power LED driver	80 to 400 mA	+/-1%	+/-6%	STEVAL-ILL009V5
STP24DP05	24-bit with diagnostics	3 to 80 mA	+/-3%	+/-8%	STEVAL-ILL015V1

*Also available as STP16CPC05, STP16CPC26 with balanced turn-on/turn-off feature

LED array driver portfolio features



Standard constant-current
LED drivers



STP08CP05, STP16CP05, STP16CPC26

Low-current/high-accuracy
LED array drivers



STP16CPP05, STP16DPP05,
STP16CPPS05, STP16DPSS05

LED array drivers with
error detection



STP08DP05, STP16DP05, STP16DPP05,
STP16DPS05, STP16DPSS05

LED array drivers
with auto shutdown



STP16CPS05, STP16CPPS05,
STP16DPS05, STP16DPSS05

LED array drivers
with balanced T_{ON}/T_{OFF}



STP16CPC05, STP16CPC26

LED array drivers
with PWM brightness control



STP1612PW05

LED array drivers
for RGB solutions



STP04CM05, STP24DP05,

STP08CP/DP05 – 8-channel, 5 to 100 mA



LED array drivers

Key features

- Low-voltage power supply: 3 to 5.5 V
- 8 constant-current output channels
- 8-bit shift register
- Serial data in/parallel data out
- Output current: 5 to 100 mA
- Adjustable output current through external resistor
- Maximum clock frequency: 30 MHz
- 3.3 V microcontroller drivable
- Current accuracy: +/-1.5% between bits
STP08CP05: +/-3% between ICs
STP08DP05: +/-5% between ICs
- ESD protection: 2.5 kV HBM, 200 V MM
- Extended thermal shutdown and protection features
- Shorted- and open-output error detect: STP08DP05

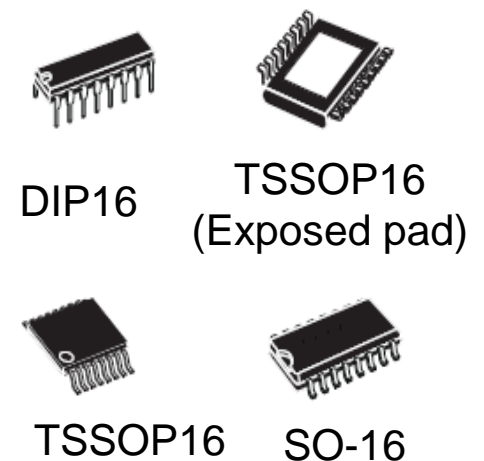
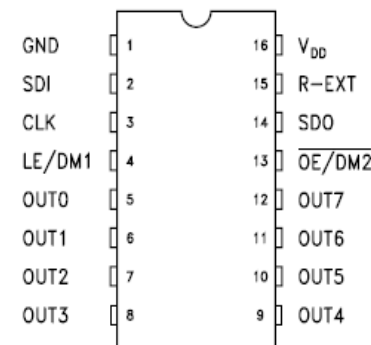
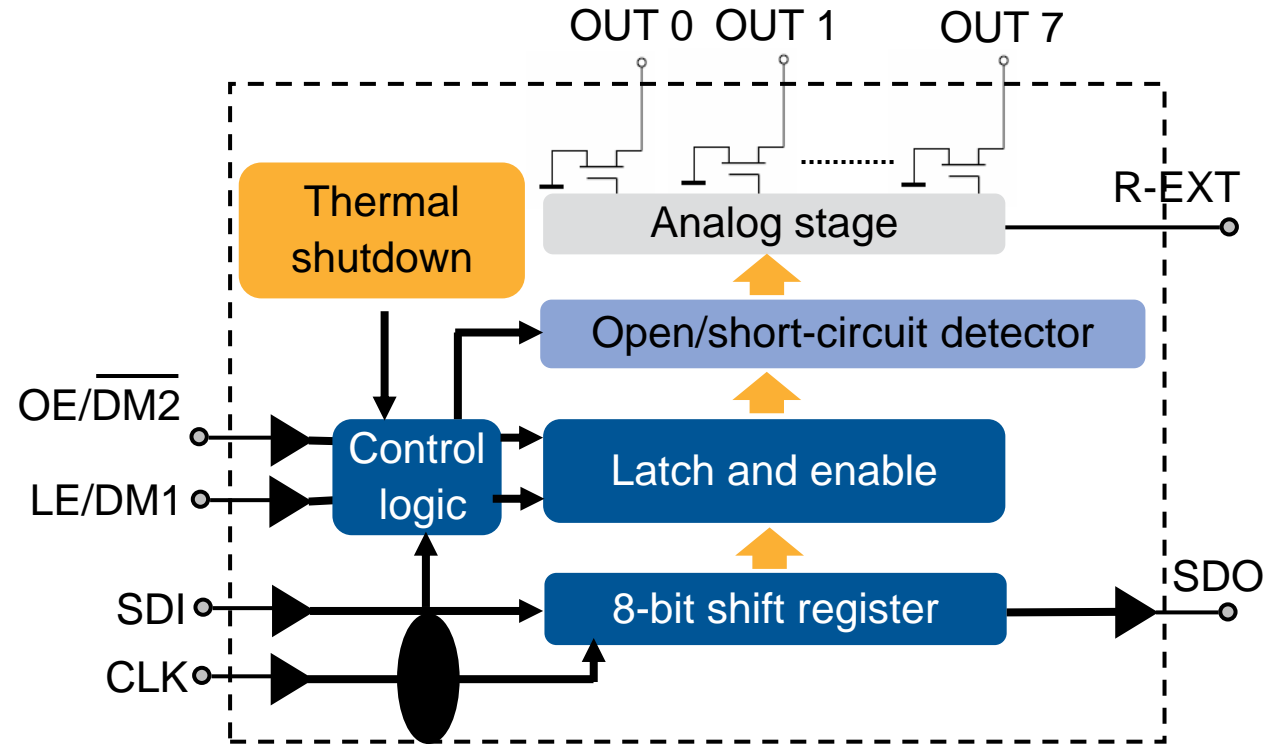

STP08DP05 with diagnostics



LED driver evaluation board solution

Key features

- 40 LED matrix with
 - Error detection
 - Current regulation
 - Adjustable brightness
 - Animated text
 - Adjustable blinking speed
- GUI SW for LED diagnostics
- Input voltage from 7 to 32 V
- DC-DC converter for high efficiency
- Standard supply connector

Key products

- STP08DP05 LED constant-current driver
- ST7FLite39 8-bit microcontroller (10-bit ADC, SPI, SCI communication)
- LE50AB Linear voltage regulator
- ST3232C RS-232 drivers and receivers
- L5970D DC-DC converter

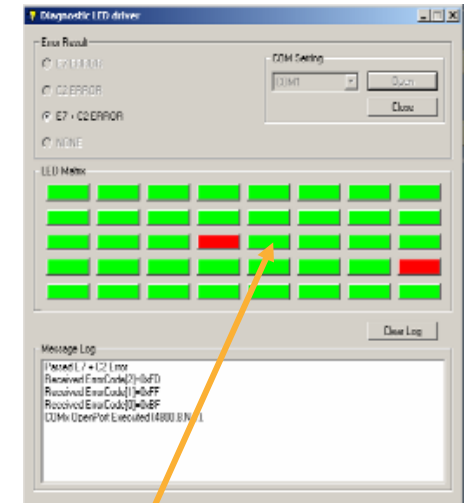
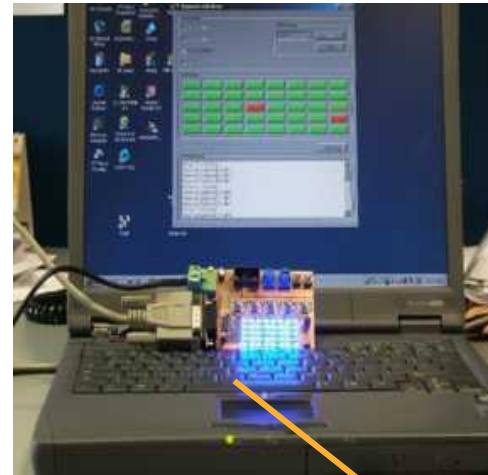

Evaluation board

App note

Description

STEVAL-ILL002V3 (Osram LEDs)
STEVAL-ILL002V4 (Vishay LEDs)

AN2478,
AN2415

High-brightness LED driver with diagnostics (40 LEDs) demonstration board

STP16CP(S)05 or STP16DP(S)05



16-channel, 5 to 100 mA LED array drivers

Key features

- Low-voltage power supply: 3 to 5.5 V
- 16 constant-current output channels
- 16-bit shift register
- Output current: 5 to 100 mA for STP16*P05 series
- Adjustable output current (external resistor)
- 3.3 V microcontroller drivable
- Maximum clock frequency: 30 MHz
- Current accuracy:
 - +/-1.5% between bits
 - +/-3% between ICs
- ESD protection: 2.5 kV HBM, 200 V MM
- Extended thermal range and protection features
- Shorted- and open-output error detect
- Auto shutdown
- Balanced output rise/fall time: typ 100 ns

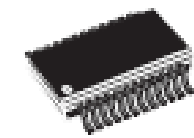
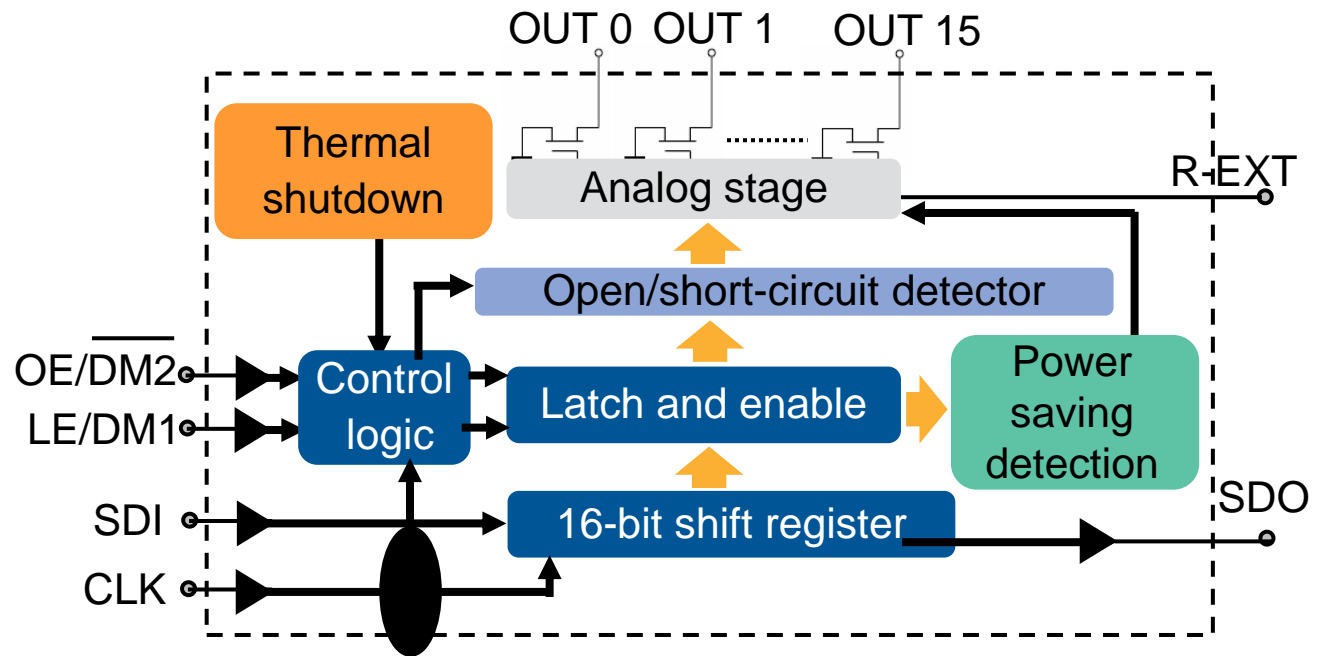

QSOP-24

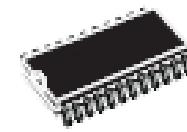

SO-24

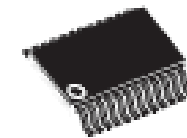

TSSOP24



TSSOP24
(Exposed pad)

STP16CP05 LED driver eval board



Key features

32 LED matrix with

- Current regulation
- Adjustable brightness
- Animated text capability
- Adjustable blinking speed
- GUI SW for LED diagnostics
- Input voltage: 5 to 35 V
- DC-DC converter for high efficiency

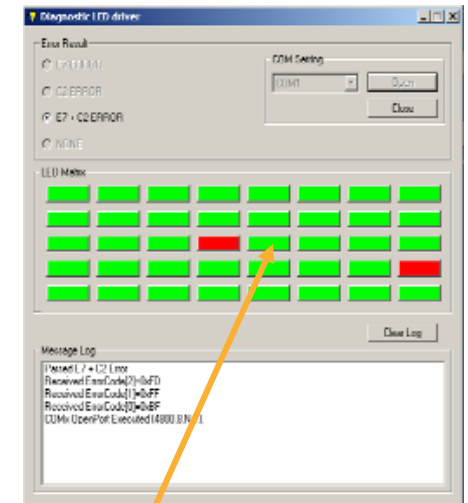
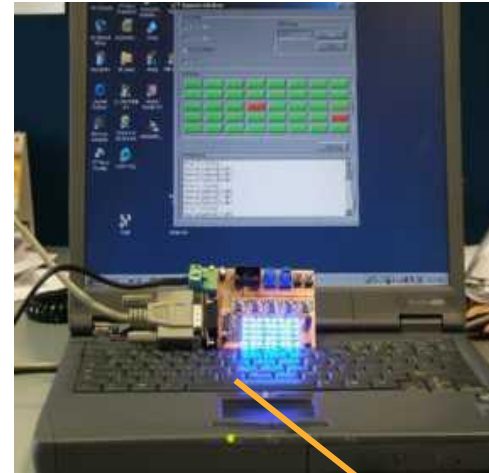

Key products

- STP16CP05 LED constant-current driver
- STP16CPS05 LED constant-current driver with auto power saving/shutdown
- ST7FLite09 8-bit microcontroller
- L78L33AC Voltage regulator
- STPS340U Schottky diode
- L5970D DC-DC converter



Evaluation board	Application note	Description
STEVAL-ILL003V2	AN2141	High-brightness 32-LED evaluation board without diagnostic based on the STP16CP05 LED driver

STP16DP05 with diagnostics



■ LED driver evaluation board solution

Key features

- 16 x 32 LED matrix display with STP16DP05
- Mother/slave board for LED display based on STM32 microcontroller
- Supports up to 8 additional display units in series
- Controlled by a single control unit supporting up to 254 display units
- Configurable through Windows HyperTerminal via serial interface and through a PS2 keyboard
- GPS interface
- Audio output-playback of pre-recorded .wav files

Key products

- STP16DP05 LED display driver
- STM32F103 32-bit ARM-based microcontroller
- STM1001 Reset IC
- ESDALC6V1W Quad Transil

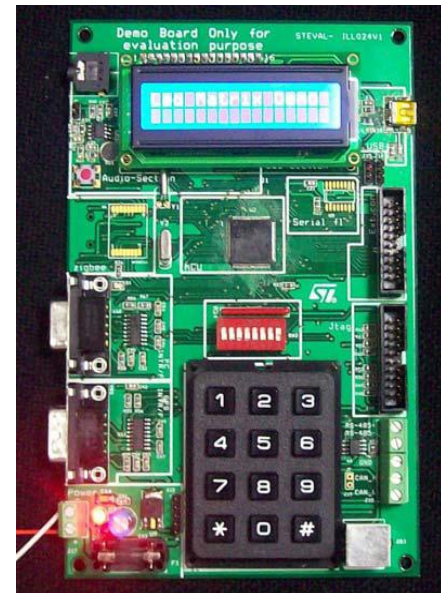

STEVAL-ILL024V1
LED matrix control
unit based on
STM32F103VB



STEVAL-ILL025V1
shows capability of
STP16DP05 in
driving LED matrix
display panel

Evaluation boards	User manual	Description
STEVAL-ILL025V1/STEVAL-ILL024V1 LED matrix control unit	UM0767	Demonstration boards based on the STP16DP05 LED matrix driver and the STM32F103VB

Error detection/diagnostic mode



Error detection



Detects open and shorted LED outputs

Normal mode:
Device works as a constant-current LED driver

Diagnostic mode:
The LED driver enters the diagnostic mode by using a digital key input to the serial data in

Detection conditions	Detection results
$I_{ODEC} \leq 0.5 \times I_O$	Open line (1) or output short to GND (2) detected
$I_{ODEC} \geq 0.5 \times I_O$	No error detected
$V_O \geq 2.4 \text{ V}$	Short on LED (3) or short to V_O (4)
$V_O \leq 2.2 \text{ V}$	No error detected

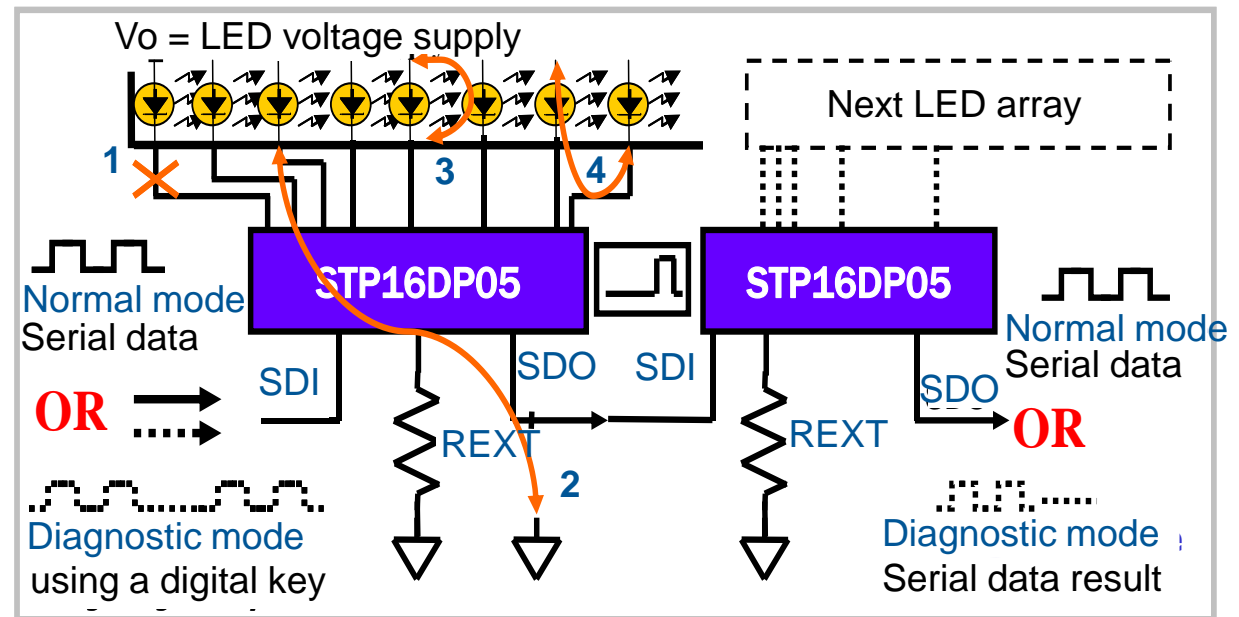

Error detection availability: STP08DP05, STP16DP05, STP16DPS05, STP16DPP05, STP16DPPS05, and STP24DP05 and STP1612PW05

Auto power saving/shutdown mode



- No active data latched → Automatically shuts down
- First active data latched → Automatically powers up

At $I_o = 80 \text{ mA}$

- Active: $I_{DD(ON)} = 11.7 \text{ mA (typ)}$
- Not active: $I_{DD(Shutdown)} = 100 \mu\text{A (typ)}$

$I_{DD(Shutdown)}$ is 117 times less than $I_{DD(ON)}$

Example

- LED panel size: 10 m x 5 m
- Estimated number of LED drivers: 10,000
- LED drivers active at any one time: ~ 20%
 - Using standard LED driver → All 10,000 consume high current (approx 117 A)
 - Using STP16DPS05 → Only 2,000 consume high current (approx 23 A)

Power savings using STP16CPS05 are ~ 80 %

Auto shutdown available in STP16CPS05,
STP16DPS05, STP16CPPS05, STP16DPSS05

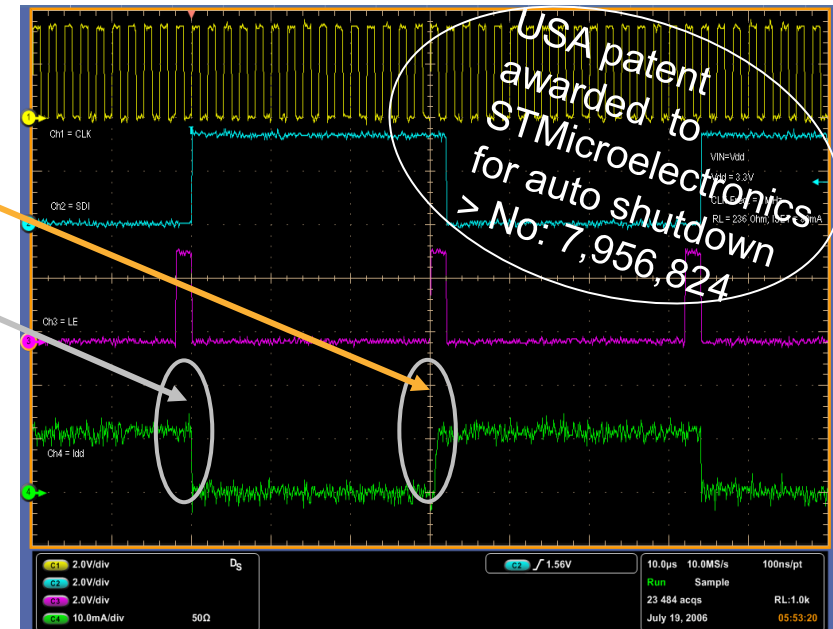

STP16CPP/DPP05 – 16-ch, 3 to 40 mA



High accuracy LED drivers

Key features

- Low-voltage power supply: 3 to 5.5 V
- 16 constant-current output channels
- 16-bit shift register
- Serial data in/parallel data out
- 3.3 V microcontroller drivable
- Maximum clock frequency: 30 MHz
- Output current:
 - 3 to 40 mA (adjustable through external resistor)
- Current accuracy:
 - +/-0.5% @ 20 mA
 - +/-2% @ 3 mA
- ESD protection: 2.5 kV HBM, 200 V MM
- Extended thermal range and protection features
- Auto shutdown available: STP16CPPS05 and STP16DPPS05

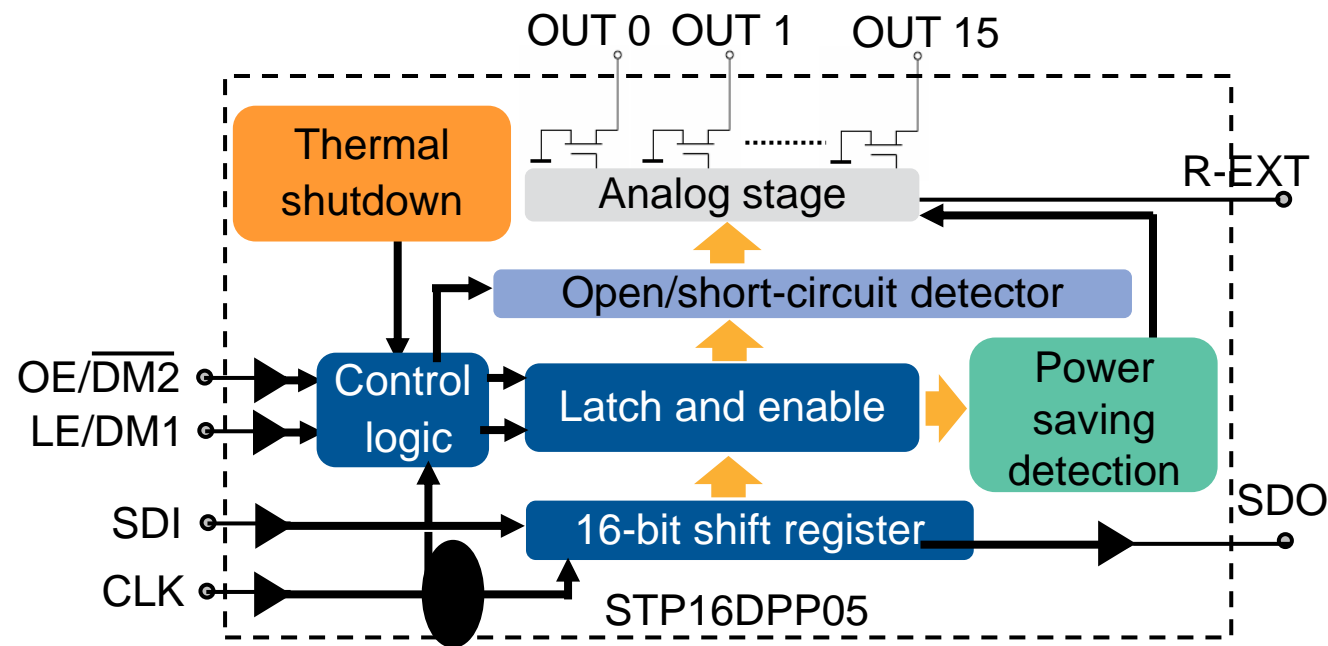

QSOP-24



SO-24



TSSOP24



TSSOP24
(Exposed pad)

STP16CPC26 – 16-channel, 5 to 90 mA



- LED with noise immunity and quasi-balanced current turn on/off

Key features:

- 5 V power supply
- 16 constant-current output channels
- Serial data in/parallel data out, cascadable
- 20 V driving capability,
 - Allows users to connect more LEDs in series to each current source
- Maximum clock frequency: 30 MHz
- Current range:
 - 5 to 90 mA adjustable through external resistor
- Channel-to-channel current accuracy:
 - +/-1% @ 20 mA
- Quasi-balanced current turn on/off at 5 mA
 - Excellent performance over full current range
 - Optimal driver dynamic response
 - Perfectly balanced current setting avoids flickering
 - No image distortion up to 4 MHz
- Better noise immunity due to higher hysteresis
- ESD protection: 2.5 kV HBM
- Thermal shutdown for over-temperature protection
- Power-on reset, undervoltage lock-out functions
- Operating temperature: -40 to 125 °C

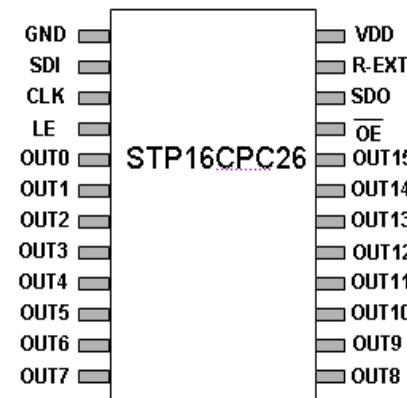
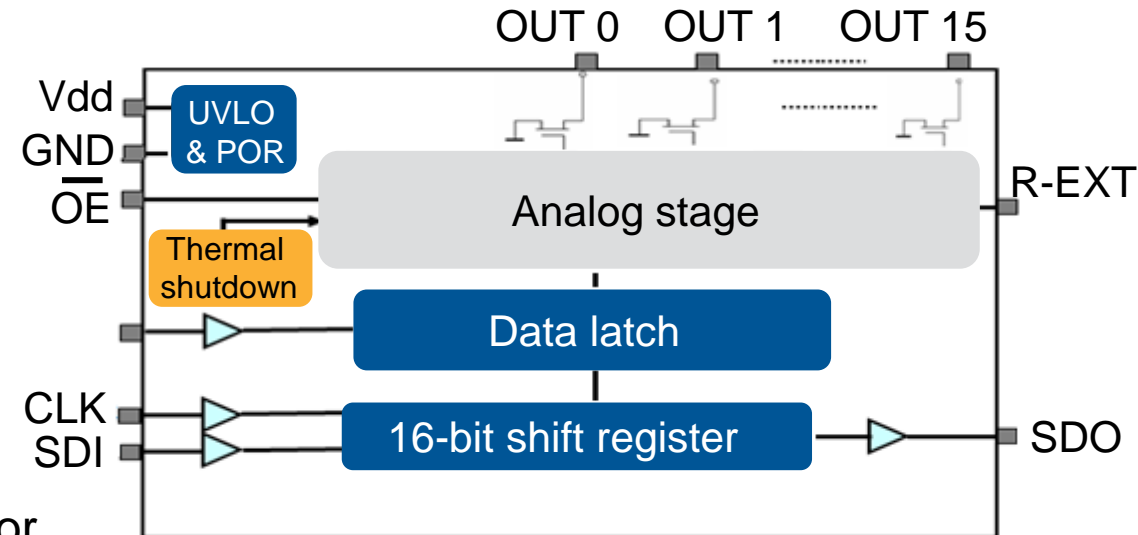

Applications

- Full color/monochrome large displays, gaming
- LED signage

Balanced turn on/off



Balanced turn on/off



Improves system performance by preventing ringing or noise generation (through EMI) due to parasitic inductance



Current
turn-on/off

Voltage
turn-on/off

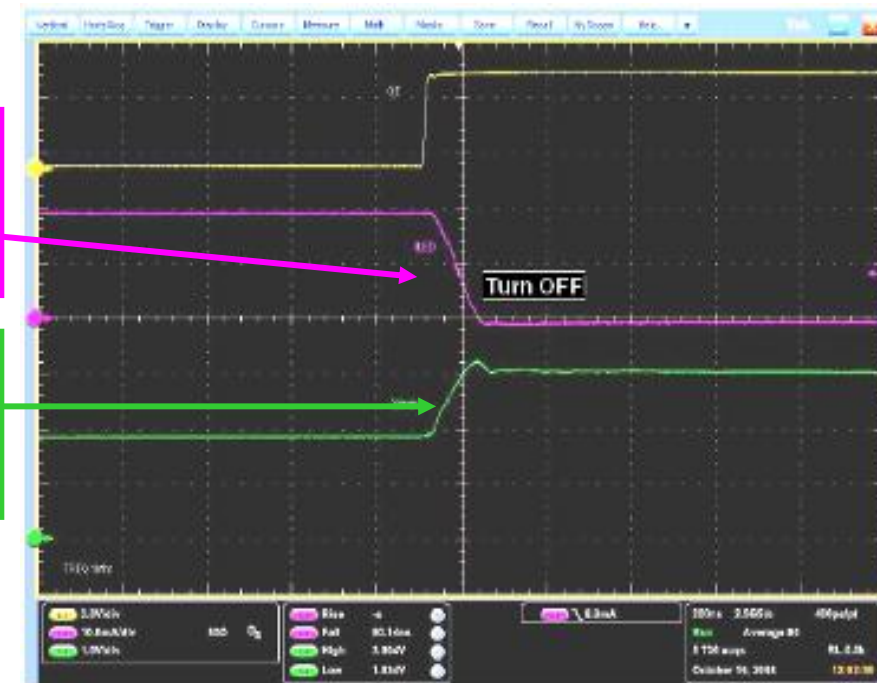

Turn-on and turn-off time typically around 100 ns
Typical T_{ON} and T_{OFF} of other products -> tens of nanoseconds

Balanced turn on/off available in STP16CPC05, STP16CPC26

STP1612PW05 –16-ch, 3 to 60 mA



LED driver with independent 12/16-bit PWM and error detection

Key features

- Low-voltage power supply: 3 to 5.5 V
- 16x 3-to-60 mA constant-current channels
- e-PWM enhanced algorithm to improve image fidelity
- Program controlled in-rush current to reduce flickering
- 12/16-bit grayscale PWM resolution with 2 counters
- 8-bit current gain control by means of 256 steps in two selectable ranges
- Full output open and shorted LED error detection
- Advanced thermal management
- 20 V output driving capability for more LEDs in series
- Maximum clock frequency: 30 MHz
- Excellent current accuracy: +/- 1.5%
- PWM CLK: time-out, power-off
- Time-out alert if clock signal is missing
- ESD protection: 2.5 kV HBM, 200 V MM
- QFN 4x4 package tiny footprint solution
- Pin-out compatible with STP16*P05 series

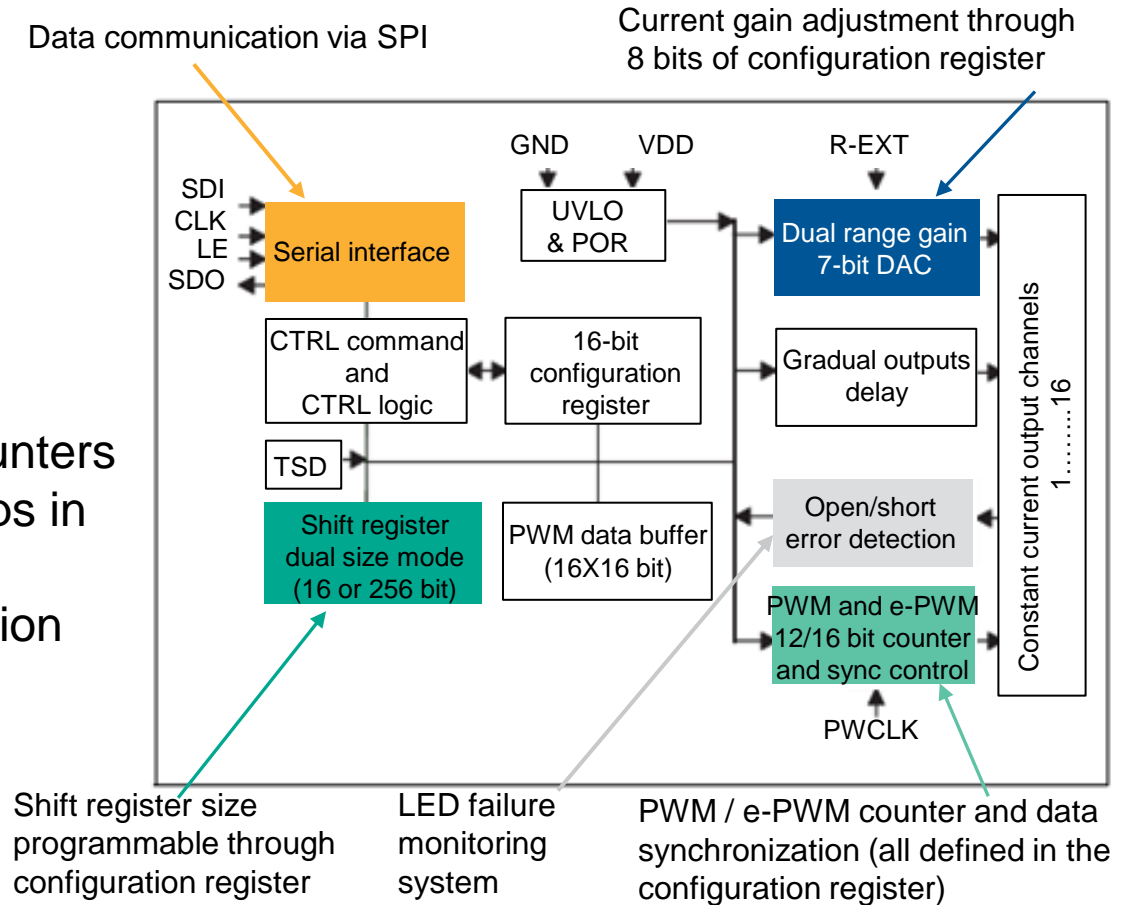

Applications

- Full motion RGB video displays
 - Monochrome LED displays
- Signs, billboards and scoreboards
- Gaming machines, channel letter signs

STP1612PW05 – control functions



Host controller

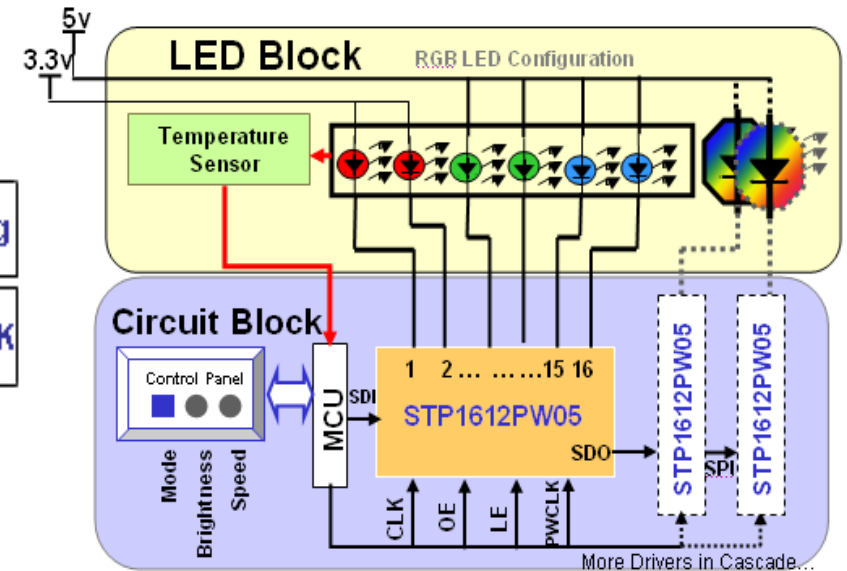
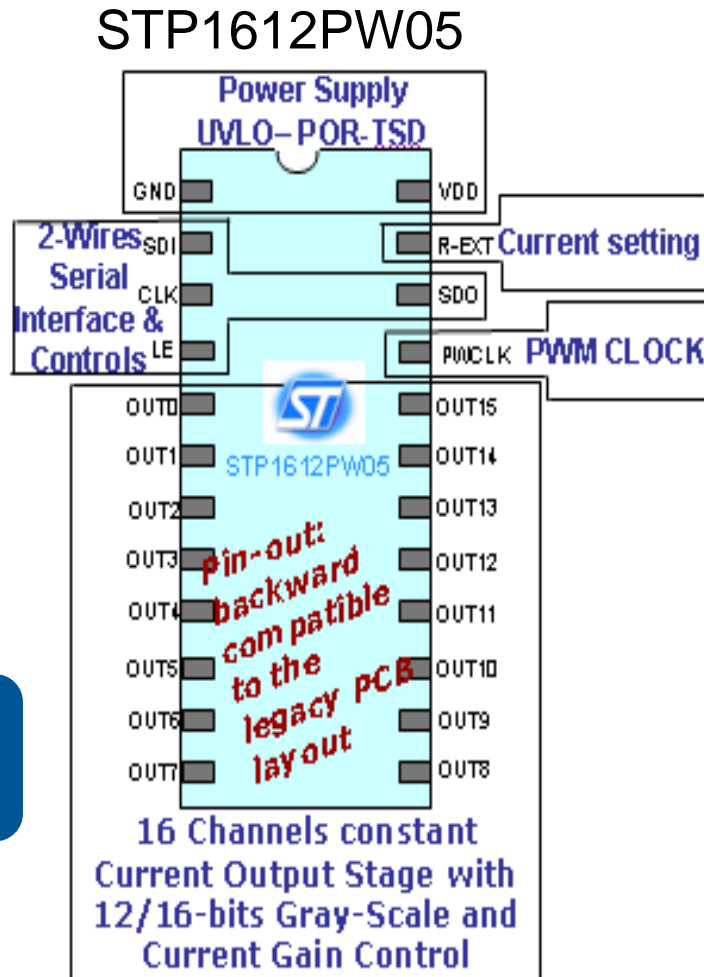
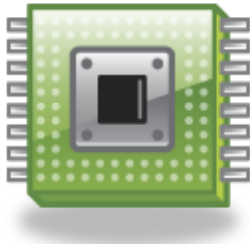

Functions available via serial key

- Data latch
- Buffer latch
- Read configuration
- Enable error detection
- Read error status
- Write configuration
- Reset register length

Functions available via configuration registers

- Set 16 or 256 SR length
- Read thermal flag
- Enable thermal shutdown
- Set PWM counter 16 or 12 bit
- Set PWM or enhanced PWM mode
- Set auto sync or manual sync
- Set current gain
- Enable PWMCLK time out disconnection

STP1612PW05 eval board



- LED display with PWM generating driver and STM32F103

Key features

- Three STP1612PW05 (16-channel LED driver with 16-bit PWM, 8-bit gain and full LED error detection)
- 6 RGB LEDs with adjustable color (48 LEDs)
- DC-DC power supply using the ST1S10
- JTAG interface for microcontroller firmware change/update
- 6 jumpers simulating LED failure for testing of the driver error detection mode
- Mini USB connector for interconnection with PC software
- Standalone demonstration firmware with animated menu



Key products

- STP1612PW05
- STM32F103
- ST1S10

Support

- High number of low-power LEDs, color or monochrome
- Open software architecture
- USB and JTAG programming connectivity for easy development with STM32 microcontroller

Evaluation board	Documentation	Description
STEVAL-ILL028V1	UM0882, UM0885	RGB LED driver for color displays and backlighting based on the STP1612PW05 and STM32

STP04CM05 – 4-channel, 80 to 400 mA



High-power LED array driver

Key features

- Low-voltage power supply: 3 to 5.5 V
- 4 constant-current output channels
- 4-bit shift register
- Adjustable output current: 80 to 400 mA using a single external resistor
- 20 V output driving capability
- Serial data in/parallel data out
- Output enable pin for dimming (PWM)
- Maximum clock frequency: 30 MHz
- ESD protection: 2.5 kV HBM, 200 V MM
- Extended thermal range and protection features

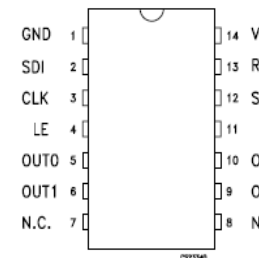
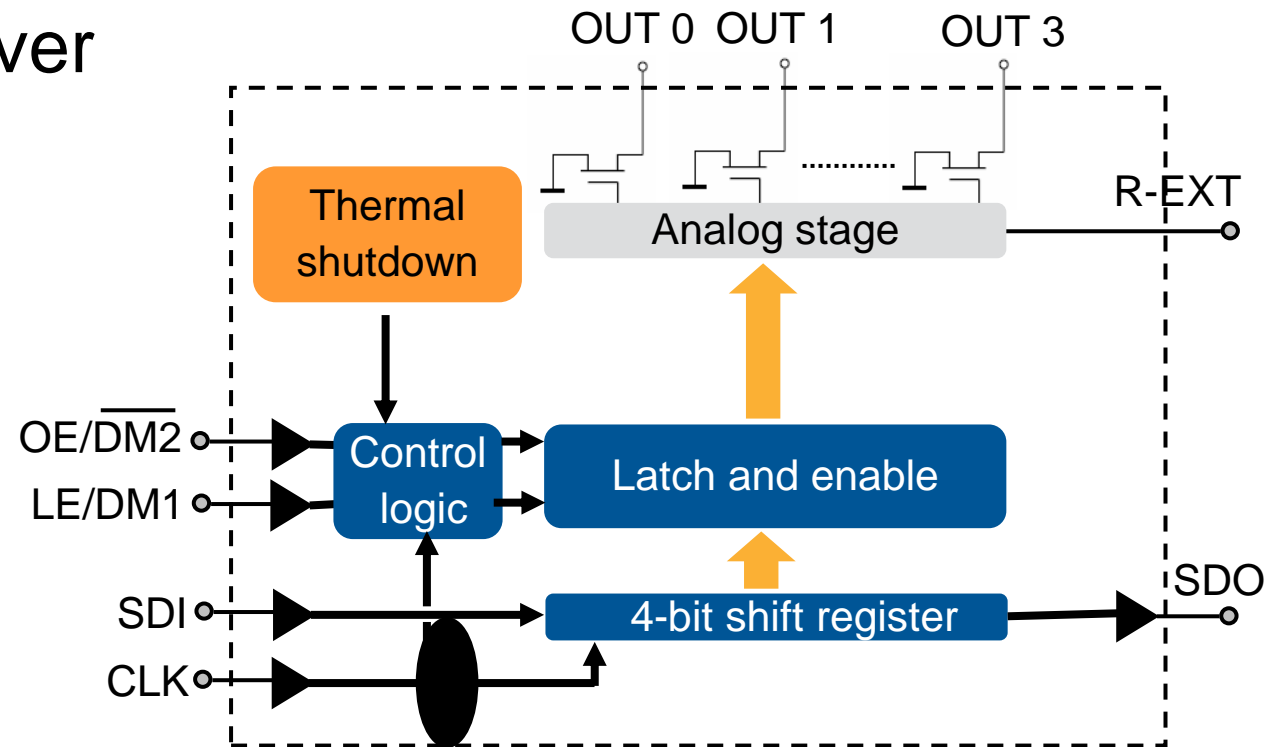

Dip-14/SO-14

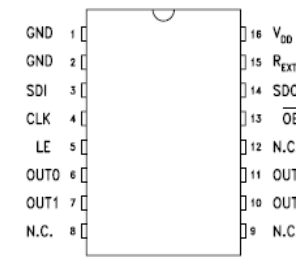

TSSOP16
(Exposed pad)



Dip-14



SO-14



TSSOP16
(Exposed pad)

Applications

- Very high brightness displays
- Special lighting applications
- High-power LEDs

STP04CM05 LED driver eval board



Key features

- Drives super high brightness multicolor RGB LEDs
- 8 LEDs can be driven with 350 mA or 4 LEDs with 700 mA
- 6 lighting modes
- 64 brightness levels for each LED
- 3 A, 4 V DC-DC converter using the ST1S10 for input voltage range (7 to 18 V)
- LED drivers STP04CM05 and STP08CP05
- Input overvoltage protection with Transil SMAJ15A
- Protection against input voltage reversion

Key products

- STP04CM05 LED driver
- STP08CP05 LED driver
- ST7FLITE09 8-bit microcontroller
- L78L05AC Voltage regulator
- ST1S10 DC-DC converter
- STLM20 Temperature sensor
- SMAJ15A-TR Transil

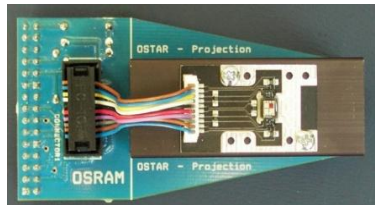

STEVAL-ILL009V3

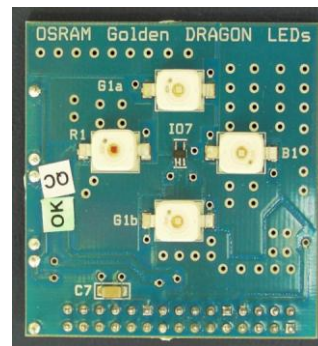

STEVAL-ILL009V4



STEVAL-ILL009V5

Evaluation board	Application note	Description
STEVAL-ILL009V5 (replaces STEVAL-ILL009V1)	AN2531	RGB color LED demonstration board based on the STP04CM05 and ST1S10
STEVAL-ILL009V3 STEVAL-ILL009V4	See above	OSTAR projection module load board Golden Dragon LEDs load board

STP24DP05 – 24-channel, 5 to 80 mA



Key features

- Low-voltage power supply: 3 to 5.5 V
- 24-bit shift registers
- Serial data in/parallel data out
- 3 groups (RGB) of 8 constant-current output channels from 5 to 80 mA
- Shorted and open output error detection
- Adjustable output current through external resistor for each group of 8 channels
- Gradual output delay (30 ns for each RGB group)
- 3.3 V microcontroller drivable
- Maximum clock frequency: 25 MHz
- ESD protection: 2.5 kV HBM, 200 V MM
- Thermal shutdown with flag pin

Applications

- Full-color high-resolution LED panel displays
- Colored traffic signs

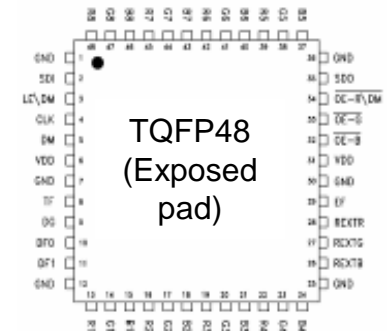
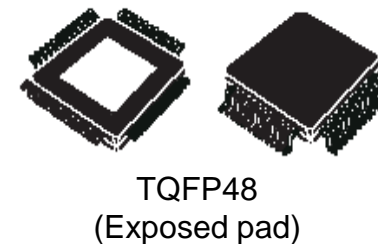
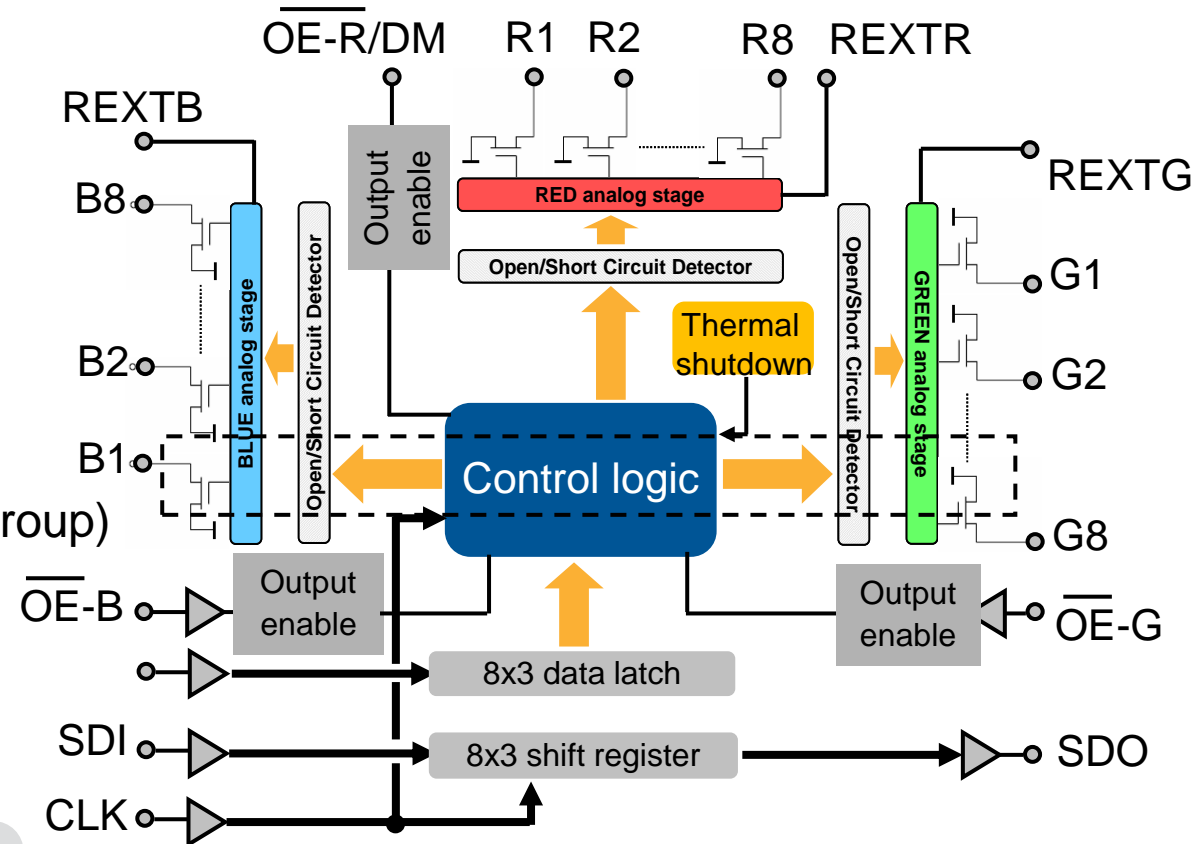

HB RGB dimmer evaluation board



Based on STP24DP05 and STM32F103C6

Key features

- Two STP24DP05 (TQFP48) with 16 RGB high-brightness LEDs connected (48 LEDs in total)
- STM32 with cost-effective internal HS oscillator
- High-efficiency DC-DC switching power supply ST1S10 with input voltage range of 7.5 to 18 V, current 0.7 A
- Error detection feature/over-temperature flag
- Adjustable brightness
- JTAG interface for C firmware updates
- Mini USB connector for PC GUI connection
- Imp signal test points for lab evaluation
- Buttons and knob to control the board
- 3 jumpers each for simulating disconnection and simulating shorting of 3 LEDs

Key products

- STP24DP05
- STM32F103
- ST1S10

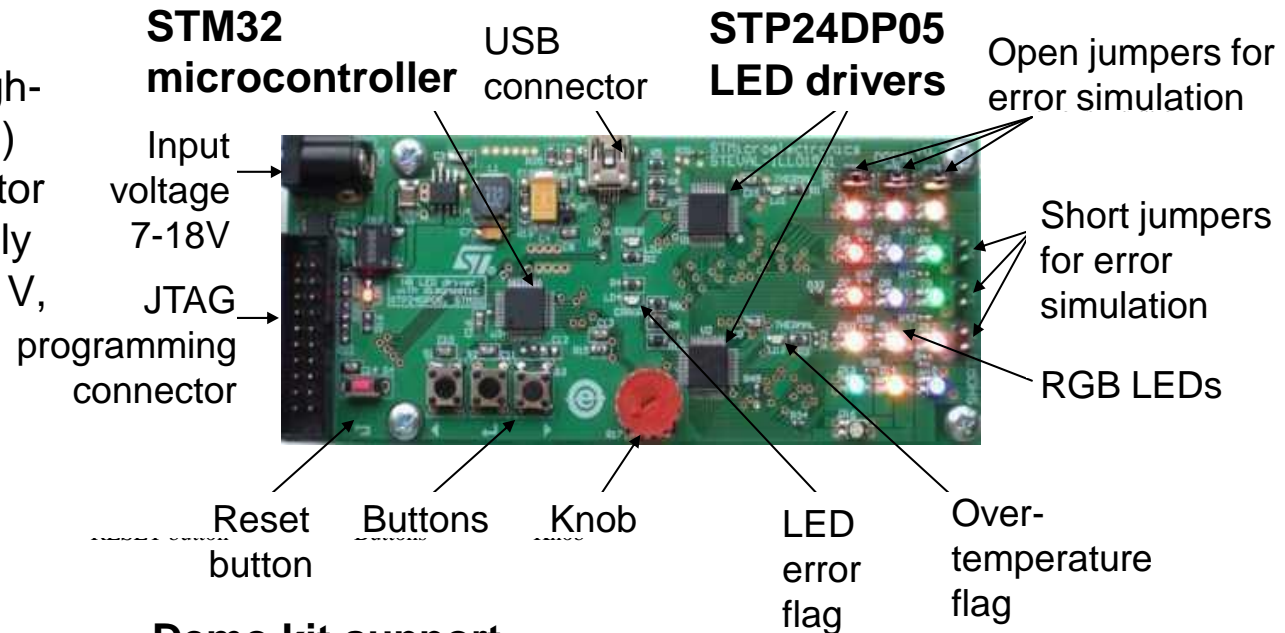

Demo kit support

- STEVAL-ILL015V1 with Osram LEDs
- CD with user manual, application note, datasheets
- C library for dimming control of every single LED
- Demo firmware and PC software:
- Standalone: games, color dimming effects, error detection
- USB demo: error detection over USB

Evaluation board	App notes /User manuals	Description
STEVAL-ILL015V1	AN2841, UM0574, UM0588	High brightness RGB LED array dimmer demo board based on the STP24DP05 and STM32

Multicolor LED display panel



- Evaluation board – RGB moving message display system with STP24DP05 and STM32F103

Key features

- Control unit with PS2 keyboard interface for data entry
- LCD on control unit for showing the display text and background color options
- 4x STP24DP05 for each display panel
- 8 panels can be cascaded in series through flat ribbon cable
- System configuration in typing data mode or in audio playback mode or in demo mode

Key products

- STP24DP05 LED display driver
- STM32F103 32-bit microcontroller on control board
- STM1001 Reset IC
- STPS3L60 Schottky diode
- ST3232C 3 V RS-232 com interface



STEVAL-ILL032V1*



STEVAL-ILL033V1*

Support

- Full-color display panels
- Airport and railway information systems
- Bank currency conversion rate boards

Evaluation board	User manuals	Description
STEVAL-ILL032V1*, STEVAL-ILL033V1*	UM1449	STM32-based RGB LED matrix display demo

* Available in Q4/2011

LED array driver feature summary



Part number	#ch	I _{LED} (mA)	ΔI _{LED}		Error detect	Auto power saving	Balanced turn on/off	Gray-scale brightness control	Current gain adjustment	Staggered output delay
			Channel to channel (max)	IC to IC (max)						
STP04CM05	4	80 - 400	±1.5% (80 to 400 mA)	±6%						
STP08CP05	8	5 - 100	±3% (20 to 100mA)	±6%						
STP08DP05	8	5 - 100	±3% (20 to 100mA)	±6%	✓					
STP16CP05	16	5 - 100	±3% (20 to 100mA)	±5%						
STP16CPS05	16	5 - 100	±3% (20 to 100mA)	±5%		✓				
STP16DP05	16	5 - 100	±3% (20 to 100mA)	±5%	✓					
STP16DPS05	16	5 - 100	±3% (20 to 100mA)	±5%	✓	✓				
STP16CPP05	16	3 - 40	±3% (20 to 40mA)	±5%						
STP16CPPS05	16	3 - 40	±3% (20 to 40mA)	±5%		✓				
STP16DPP05	16	3 - 40	±3% (20 to 40mA)	±5%	✓					
STP16DPPS05	16	3 - 40	±3% (20 to 40mA)	±5%	✓	✓				
STP16CPC05	16	5 - 100	±3% (20 to 100mA)	±5%			✓			
STP16CPC26	16	5 - 90	±3%	±6%			✓			
STP24DP05	24	5 - 80	±6% (5 to 15mA) ±3% (15 to 80mA)	±6%	✓					✓
STP1612PW05	16	3 - 60	±1.5% (3 to 60mA)	±6%	✓			✓	✓	✓

Evaluation boards summary



Part number	Order code	Description	Feature	App notes	Power supply
STP16CP05 STP16CPS05	STEVAL-ILL003V2	32-LED array reference board	<ul style="list-style-type: none"> - Adjustable brightness, blinking speed - Animated text - GUI SW for LEDs diagnostics 	AN2241	Std supply connector
STP16DP05	STEVAL-ILL024V1 STEVAL-ILL025V1	Mother/slave board for LED display based on STM32 16x32 LED matrix	<ul style="list-style-type: none"> - Animated text - Adjustable blinking speed - GPS interface 	UM0767	5V, 0.5A 3.5V-5V, 3A
STP1612PW05	STEVAL-ILL028V1	RGB LED driver with independent PWM for color display via STM32 SPI	<ul style="list-style-type: none"> - Adjustable color - JTAG interface for C firmware update 	UM0882 UM0885	Std supply connector
STP08DP05	STEVAL-ILL002V3	40-LED diagnostic reference board using Osram blue LEDs	<ul style="list-style-type: none"> - Adjustable brightness, blinking speed - Animated text - Error detection feature 	AN2415 AN2478	Std supply connector
STP08DP05	STEVAL-ILL002V4	40-LED diagnostic reference board using Vishay green LEDs	<ul style="list-style-type: none"> - Adjustable brightness, blinking speed - Animated text - Error detection feature 	AN2415 AN2478	Std supply connector
STP04CM05	STEVAL-ILL009V3 STEVAL-ILL009V4 STEVAL-ILL009V5	RGB LED reference board OSTAR projection module Golden Dragon LEDs	<ul style="list-style-type: none"> - Adjustable brightness, blinking speed - Animated text - Power LED driving 	AN2531	Std supply connector
STP24DP05	STEVAL-ILL015V1	16 RGB LED array based on STP24DP05 and STM32F103C6	<ul style="list-style-type: none"> - Adjustable brightness - JTAG interface for C firmware update - Mini USB connector for PC GUI - Error detection feature 	UM0574	Std supply connector
STP24DP05	STEVAL-ILL032V1 STEVAL-ILL033V1	STM32-based RGB LED matrix display demo	<ul style="list-style-type: none"> - Adjustable text color and speed - Adjustable background color - Audio playback mode 	UM1449	Std supply connector

LED lighting brochure

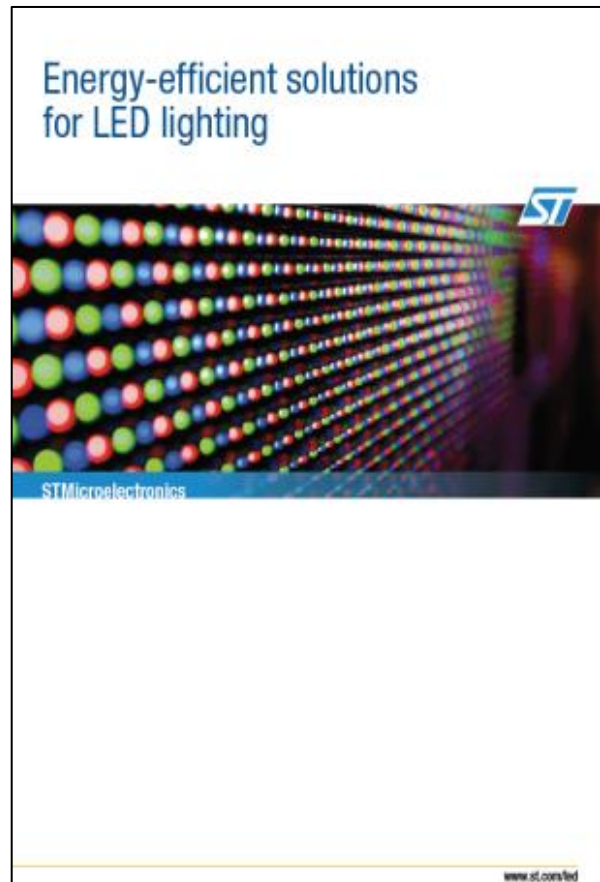

LED application web pages

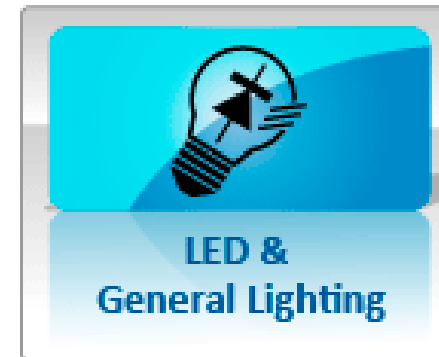

http://www.st.com/internet/com/SALES_AND_MARKETING_RESOURCES/MARKETING_COMMUNICATION/MARKETING_BROCHURE/brlighting.pdf

<http://www.st.com/internet/com/segment/412.jsp>

Thank you



For more information, visit:

www.st.com > tools & resources

www.st.com > LED displays and signage