

# LED lighting solutions for traffic signals

---

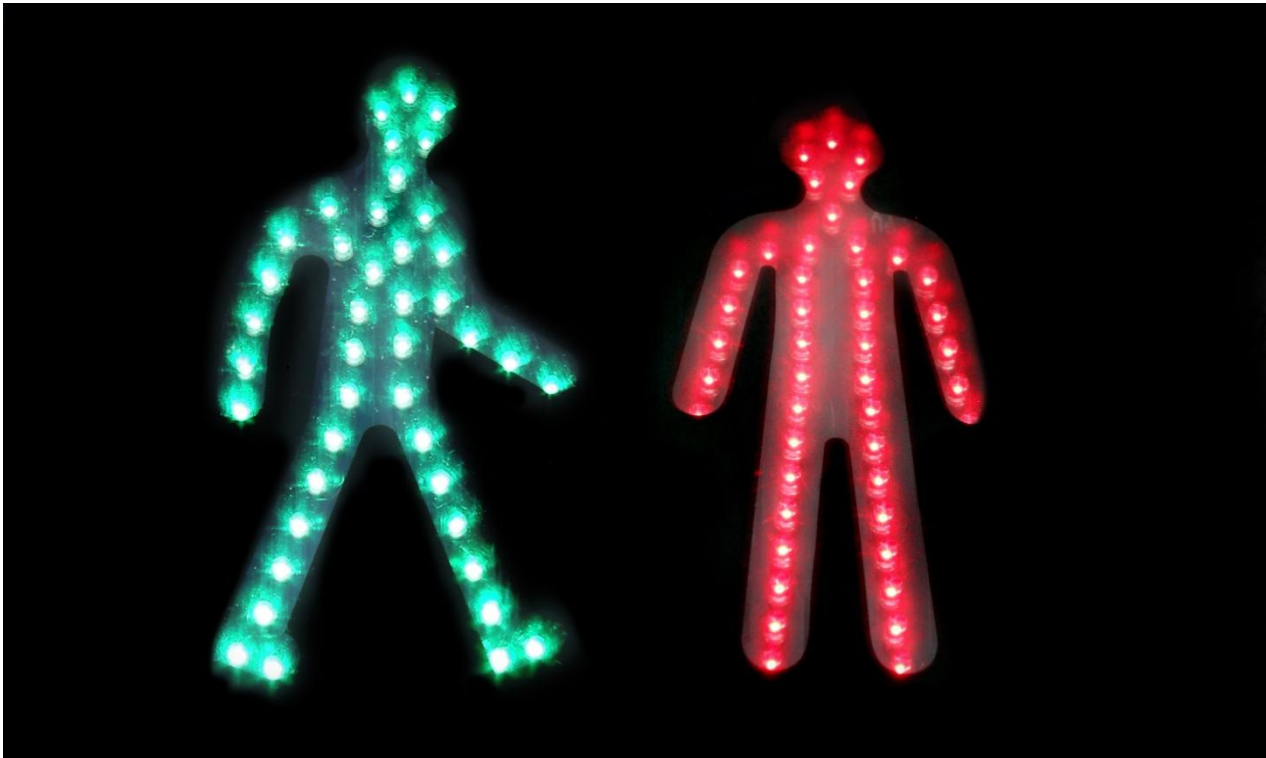

# LED lighting solutions for traffic signals

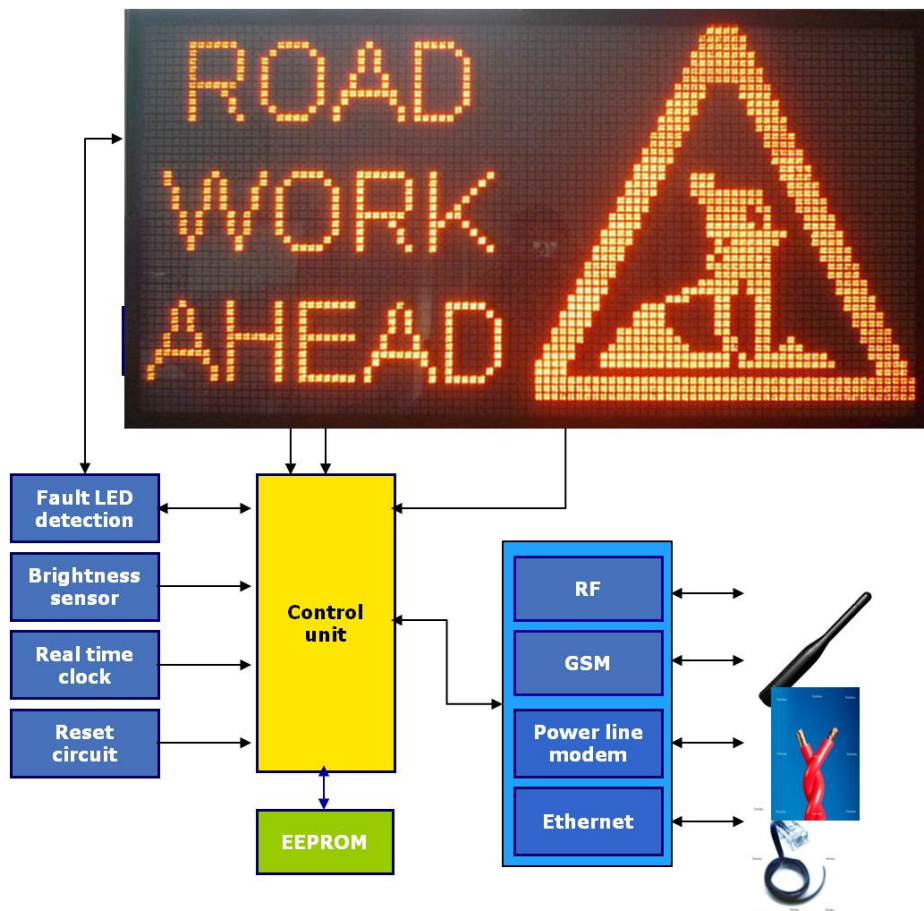

1

## ST's position

- #1 in lighting segment\*
- #2 in power management\*\*

## ST's expertise

- System solutions
- Technology integration and innovation
- Excellent technical support

\*STMicroelectronics, Datapoint and Darnell - 2008

\*\*iSupply - 2010

- LED lighting solutions for traffic signals
  - LED array driver features/benefits
    - Error detection/diagnostics
    - Auto power savings/shutdown
    - High precision
    - Balanced turn-on/off
  - System evaluation boards and tools
    - HB LED driver solution with diagnostics (32, 40 LEDs)
    - 16 x 32 LED matrix display panel
    - RGB LED driver for color displays and backlighting
    - High-brightness LED array dimmer solution
    - RGB moving message display system
    - LED driver w/PWM dimming and boost converter solution

# LED lighting solutions for traffic signals

## Main LED applications

- Traffic panels/matrixes
- Aviation
- Rail
- Navigation
- Emergency/police signals
- Crossing lights

**STP08DP05,  
STP16DP\*05, STP24DP05  
families, LED7706/7**

## STP\*\* array drivers

- Constant-current drivers, set by only one external resistor
- Serial data and clock resynchronization
- High current and high precision
- Thermal shutdown
- Error detection and auto power saving

LED7706/7 DC-DC converters



# LED array driver general portfolio



## STP\*\*\*\*05 series features

- Absolute output voltage up to 20 V
- Output enable frequency up to 1 MHz
- SDI and CLK resynchronized device by device w/o use of CLK falling edge
- Analog thermal shutdown protection
- Clock frequency over 30 MHz
- TSSOP package with exposed pad
- Extended junction temperature range of -40 to 125 °C

C: Constant current

P: Precision

PP: Precision and lower output current range (3 to 40 mA output current)

D: Error detection/diagnostic

S: Auto-shutdown

Part number	Description	I <sub>out</sub>	Bit precision	Chip precision	Evaluation board
STP08CP05	8-bit CC LED driver	5 to 100 mA	+/-1%	+/-3%	STEVAL-ILL009V5
STP08DP05	8-bit CC LED driver w/diagnostics	5 to 100 mA	+/-1.5%	+/-5%	STEVAL-ILL002V3 STEVAL-ILL002V4
STP16CP(P)(S)05*	16-bit w/auto power saving	5 to 100 mA	+/-1.5%	+/-5%	STEVAL-ILL003V2
STP16DP(P)(S)05	16-bit with diagnostics	5 to 100 mA	+/-1.5%	+/-5%	STEVAL-ILL025V1
STP1612PW05	16-bit w/12/16-bit e-PWM	3 to 80 mA	+/-1.5%	+/-6%	STEVAL-ILL028V1
STP24DP05	24-bit with diagnostics	3 to 80 mA	+/-3%	+/-8%	STEVAL-ILL015V1

\*Also available as STP16CPC05, STP16CPC26 with balanced turn-on/turn-off feature

# LED array driver portfolio features



Standard constant-current  
LED drivers



STP08CP05, STP16CP05, STP16CPC26

Low-current/high-accuracy  
LED array drivers



STP16CPP05, STP16DPP05,  
STP16CPPS05, STP16DPSS05

LED array drivers with  
error detection



STP08DP05, STP16DP05, STP16DPP05,  
STP16DPS05, STP16DPSS05

LED array drivers  
with auto-shutdown



STP16CPS05, STP16CPPS05,  
STP16DPS05, STP16DPSS05

LED array drivers  
with balanced  $T_{ON} / T_{OFF}$



STP16CPC05, STP16CPC26

LED array drivers  
w/PWM brightness control



STP1612PW05

LED array drivers  
for RGB solutions



STP24DP05

# STP08DP05: 8-channel 5-100 mA drivers

## Key features

- Short and open output error detect
- Low-voltage power supply: 3 to 5.5 V
- 8 constant-current output channels
- 8-bit shift register
- Serial data in/parallel data out
- Output current: 5 to 100 mA
- Adjustable output current through ext resistor
- Maximum clock frequency: 30 MHz
- 3.3 V microcontroller drivable
- Current accuracy: +/-1.5% between bits
  - STP08CP05: +/-3% between ICs
  - STP08DP05: +/-5% between ICs
- ESD protection: 2.5 kV HBM, 200 V MM
- Extended thermal shutdown and protection features

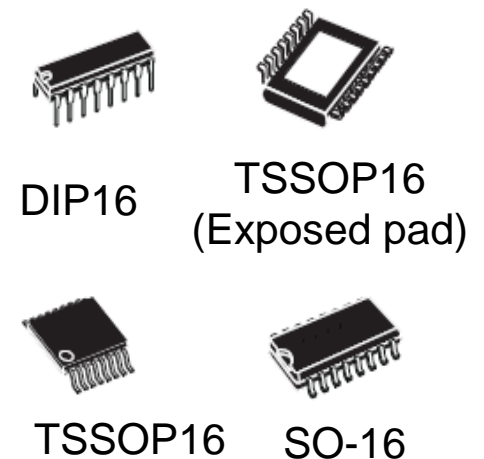
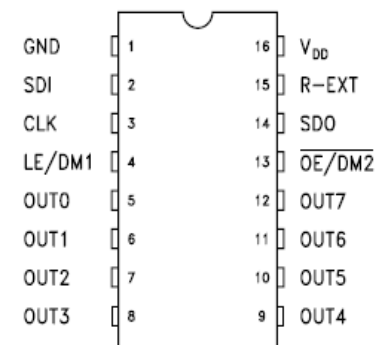
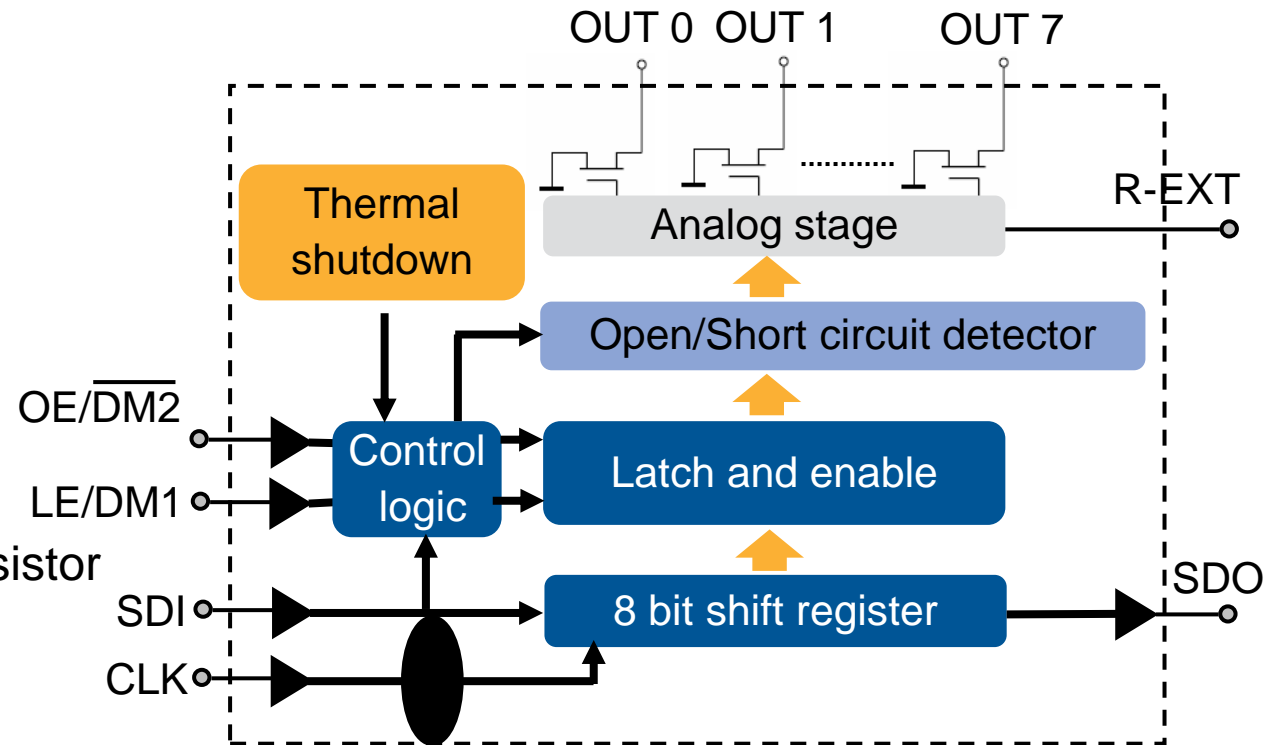

# STP08DP05 LED driver w/diagnostics



## Evaluation board solutions

### Key features

- 40 LED matrix with
  - Error detection
  - Current regulation
  - Adjustable brightness
  - Animated text
  - Adjustable blinking speed
  - GUI SW for LED diagnostics
  - Input voltage from 7 to 32 V
  - DC-DC converter for high efficiency
  - Standard supply connector

### Key products

- STP08DP05 LED constant-current driver
- ST7FLite39 8-bit microcontroller (10-bit ADC, SPI, SCI communication)
- LE50AB linear voltage regulator
- ST3232C RS-232 drivers and receivers
- L5970D DC-DC converter

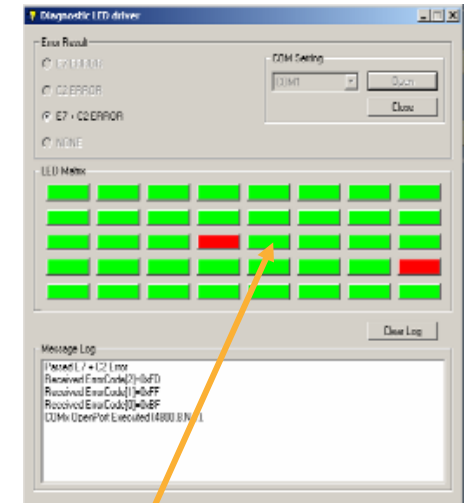
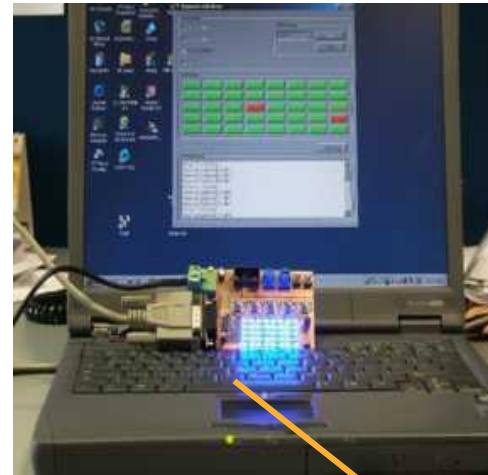

### Evaluation board

### App note

### Description

STEVAL-ILL002V3 (Osram LEDs)  
STEVAL-ILL002V4 (Vishay LEDs)

AN2478,  
AN2415

High-brightness LED driver with diagnostics (40 LEDs) demonstration board

# STP16CP(S)05 or STP16DP(S)05



## 16-channel, 5 to 100 mA LED array drivers

### Key features:

- Low-voltage power supply: 3 to 5.5 V
- 16 constant-current output channels
- 16-bit shift register
- Output current: 5 to 100 mA for STP16\*P05 series
- Adjustable output current, ext resistor
- 3.3 V microcontroller drivable
- Maximum clock frequency: 30 MHz
- Current accuracy:
  - +/-1.5% between bits
  - +/-3% between ICs
- ESD protection: 2.5 kV HBM, 200 V MM
- Extended thermal range and protection features
- Short and open output error detect
- Auto shutdown
- Balanced output rise/fall time, typ 100ns

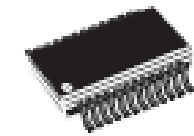
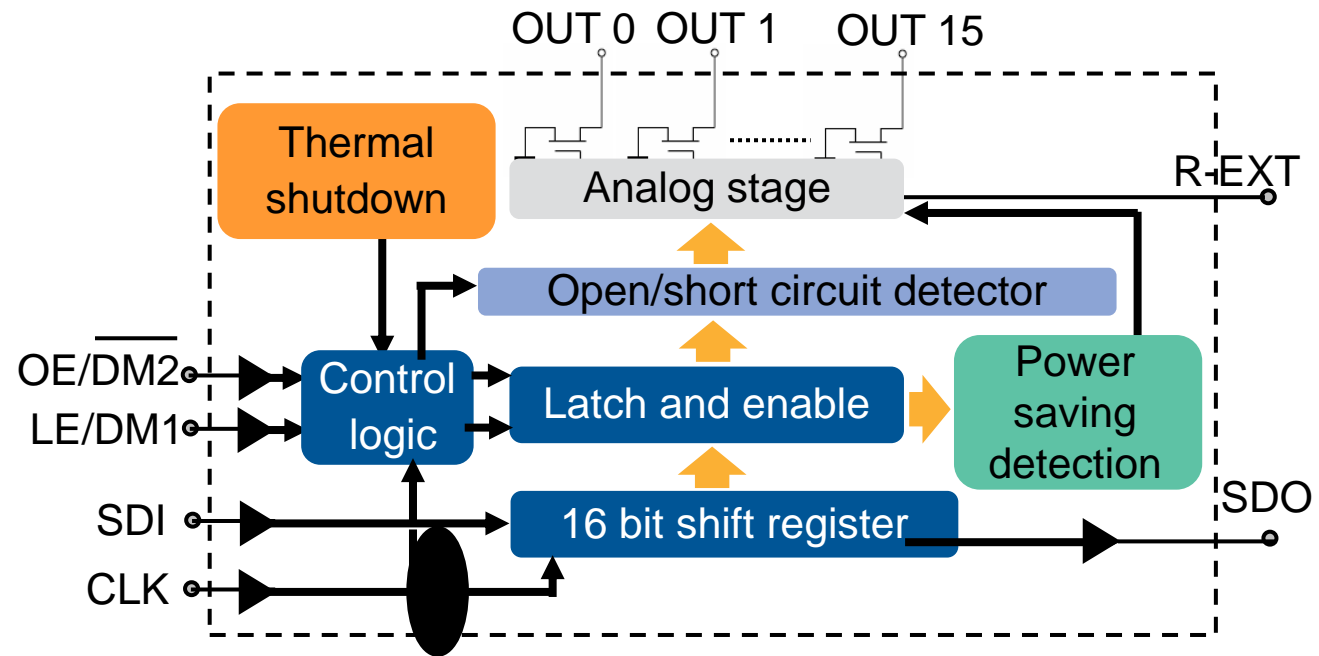

QSOP-24

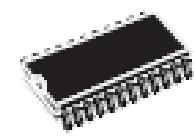

SO-24

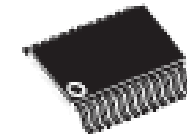

TSSOP24



TSSOP24  
(Exposed pad)

# STP16CP05 LED driver eval board



## Key features:

32 LED matrix with

- Current regulation
- Adjustable brightness
- Animated text capability
- Adjustable blinking speed
- GUI SW for LED diagnostics
- Input voltage from 5 to 35 V
- DC-DC converter for high efficiency

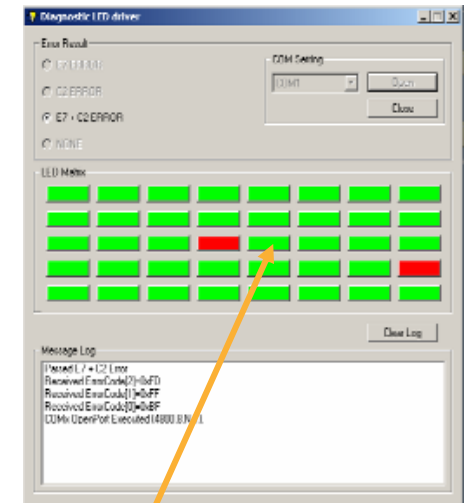
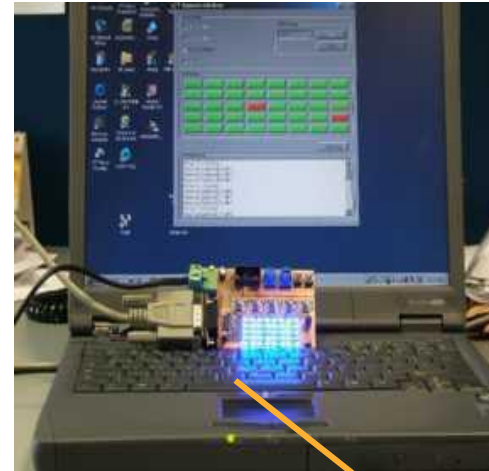

## Key products:

- STP16CP05 LED constant-current driver
- STP16CPS05 LED constant-current driver w/auto power saving/shutdown
- ST7FLite09 8-bit microcontroller
- L78L33AC voltage regulator
- STPS340U Schottky diode
- L5970D DC-DC converter



Evaluation board	Application note	Description
STEVAL-ILL003V2	AN2141	High-brightness 32-LED evaluation board without diagnostics based on the STP16CP05 LED driver

# STP16DP05 LED driver w/diagnostics



## ■ Evaluation board solution

### Key features:

- 16 x 32 LED matrix display with STP16DP05
- Mother/slave board for LED display based on STM32 microcontroller
- Supports up to 8 additional display units in series
- Controlled by a single control unit supporting up to 254 display units
- Configurable through Windows HyperTerminal via serial interface and through a PS2 keyboard
- GPS interface
- Audio output-playback of pre-recorded .wav files

### Key products:

- STP16DP05 LED display driver
- STM32F103 32-bit ARM-based microcontroller
- STM1001 reset IC
- ESDALC6V1W quad Transil

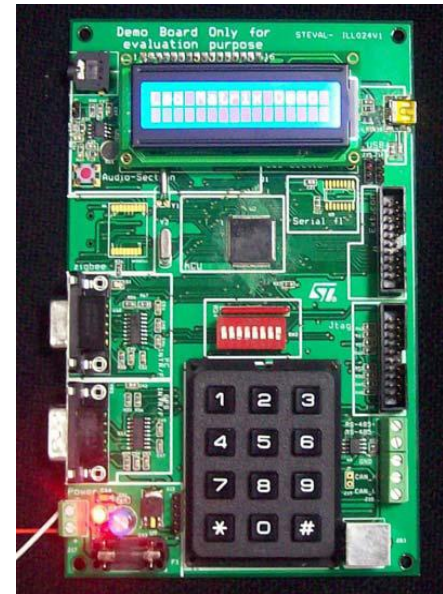

STEVAL-ILL024V1  
LED matrix control  
unit based upon  
STM32F103VB



STEVAL-ILL025V1  
shows capability of  
STP16DP05 in  
driving matrix LED  
display panel

Evaluation boards	User manual	Description
STEVAL-ILL025V1/STEVAL-ILL024V1 LED matrix control unit	UM0767	Demonstration boards based on the STP16DP05 LED matrix driver and the STM32F103VB

# Error detection/diagnostic mode



Error detection



Detects open and shorted LEDs on the output

Normal mode  
Device works like a constant-current LED driver

Diagnostic mode  
The LED driver enters the diagnostic mode by using a digital key input to the serial data in

Detection conditions	Detection results
$I_{ODEC} \leq 0.5 \times I_O$	Open line (1) or output short to GND (2) detected
$I_{ODEC} \geq 0.5 \times I_O$	No error detected
$V_O \geq 2.4V$	Short on LED (3) or short to $V_O$ (4)
$V_O \leq 2.2V$	No error detected

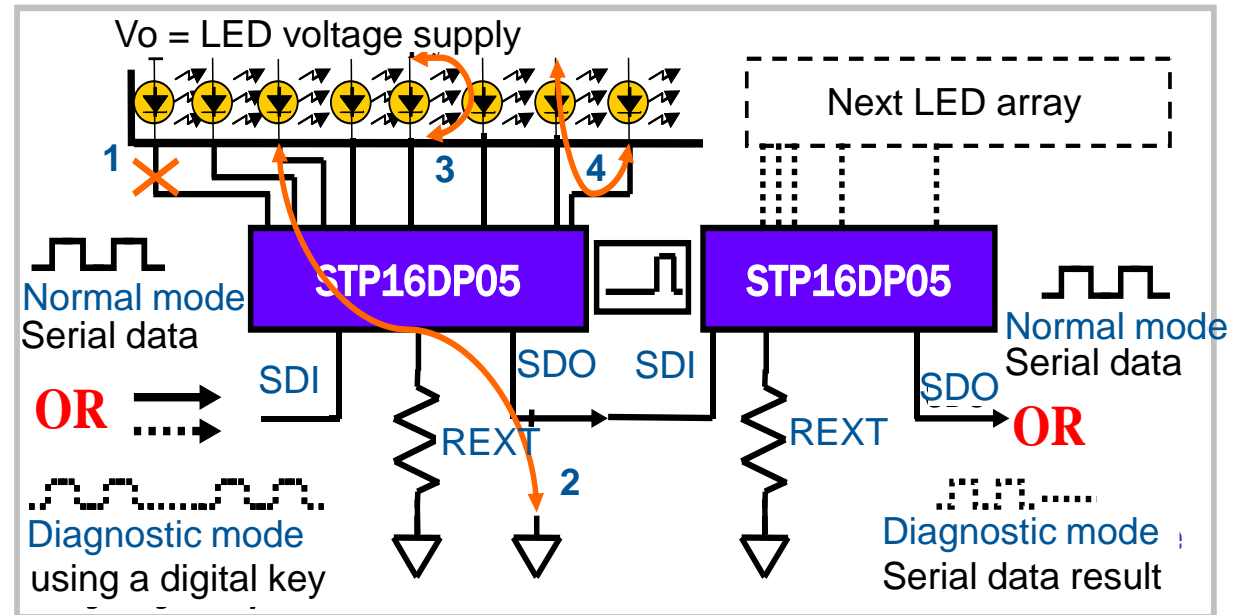

Error detection availability: STP08DP05 ,STP16DP05, STP16DPS05, STP16DPP05, STP16DPPS05, and STP24DP05 and STP1612PW05

# Autopower saving/shutdown mode



- No active data latched → Automatically shuts down
- First active data latched → Automatically powers up

At  $I_o = 80\text{mA}$

- Active:  $I_{DD(\text{on})} = 11.7\text{ mA (typ)}$
- Not active:  $I_{DD(\text{shutdown})} = 100\text{ }\mu\text{A (typ)}$

$I_{DD(\text{shutdown})}$  is 117 times less than  $I_{DD(\text{on})}$

Example:

- LED panel size: 10 m x 5 m
- Estimated number of LED drivers: 10,000 pcs
- LED drivers active at any one time: ~ 20%
  - Using std LED driver → All 10,000 consume high current (approx 117 A)
  - Using STP16DPS05 → Only 2,000 consume high current (approx 23 A)

Power savings using STP16CPS05 is ~ 80 %

Auto shutdown available in STP16CPS05,  
STP16DPS05, STP16CPPS05, STP16DPSS05

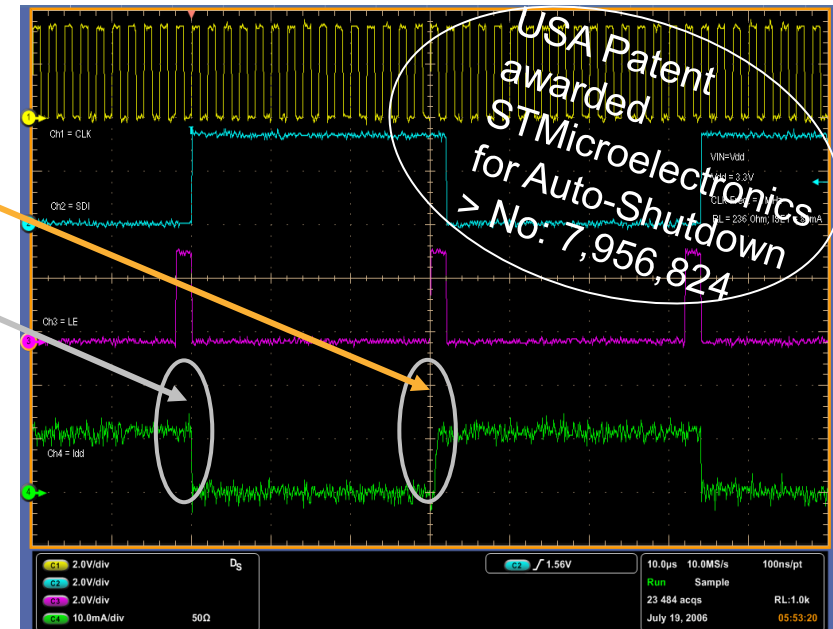

# STP16CPP/DPP05: 16-channel, 3-40 mA



## High-accuracy LED drivers

### Key features

- Low-voltage power supply: 3 to 5.5 V
- 16 constant-current output channels
- 16-bit shift register
- Serial data in/parallel data out
- 3.3 V microcontroller drivable
- Maximum clock frequency: 30 MHz
- Output current:
  - 3 to 40 mA (adjustable through external resistor)
- Current accuracy:
  - +/-0.5% @ 20 mA
  - +/-2% @ 3 mA
- ESD protection: 2.5 kV HBM, 200 V MM
- Extended thermal range and protection features
- Auto shutdown available: STP16CPPS05 and STP16DPPS05

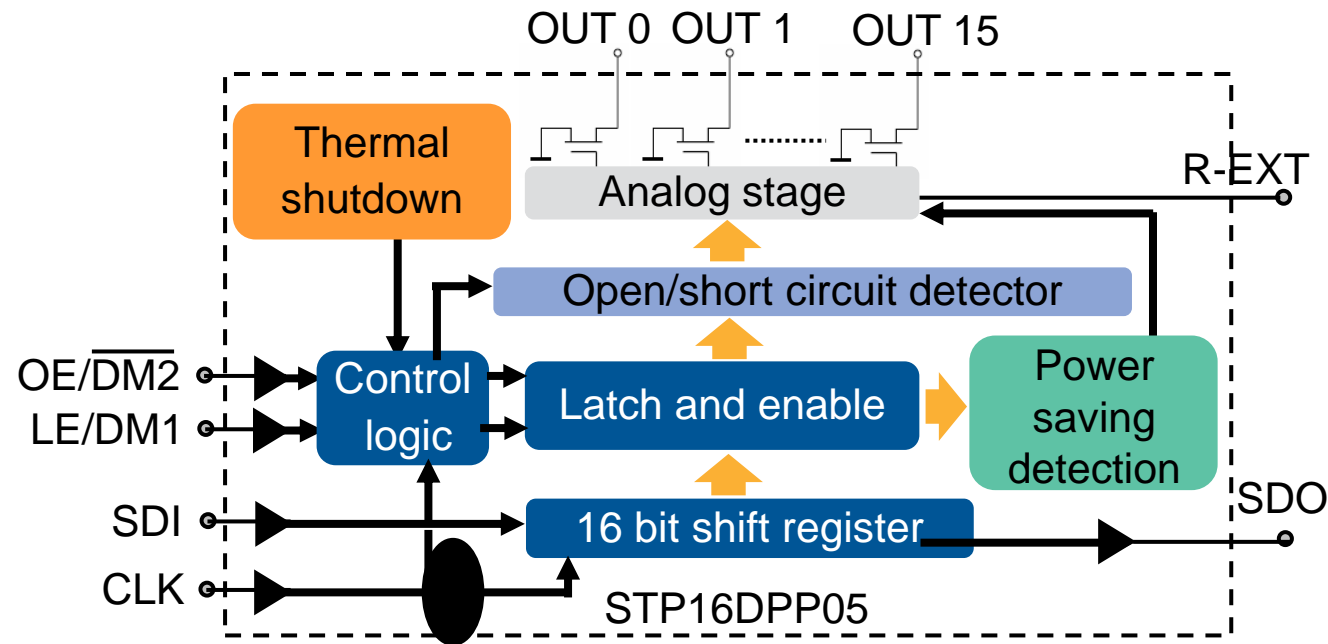

QSOP-24



SO-24



TSSOP24



TSSOP24  
(Exposed pad)

# STP24DP05: 24-channel, 5 to 80 mA



## Key features:

- Low-voltage power supply: 3 to 5.5
- 24-bit shift registers
- Serial data in/parallel data out
- 3 groups (RGB) of 8 constant-current output channels from 5 to 80 mA
- Short and open output error detection
- Adjustable output current through external resistor for each group of 8 channels
- Gradual output delay (30 ns for each RGB group)
- 3.3 V microcontroller drivable
- Maximum clock frequency: 25 MHz
- ESD protection: 2.5 kV HBM, 200 V MM
- Thermal shutdown with flag pin

## Applications

- Full color high-resolution LED panel displays
- Colored traffic signs

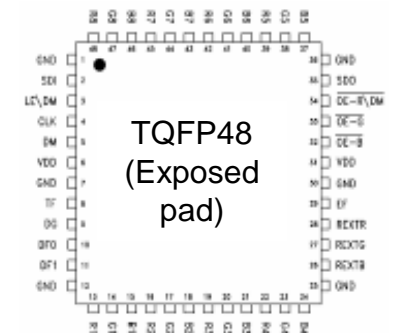
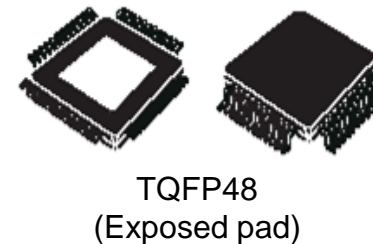
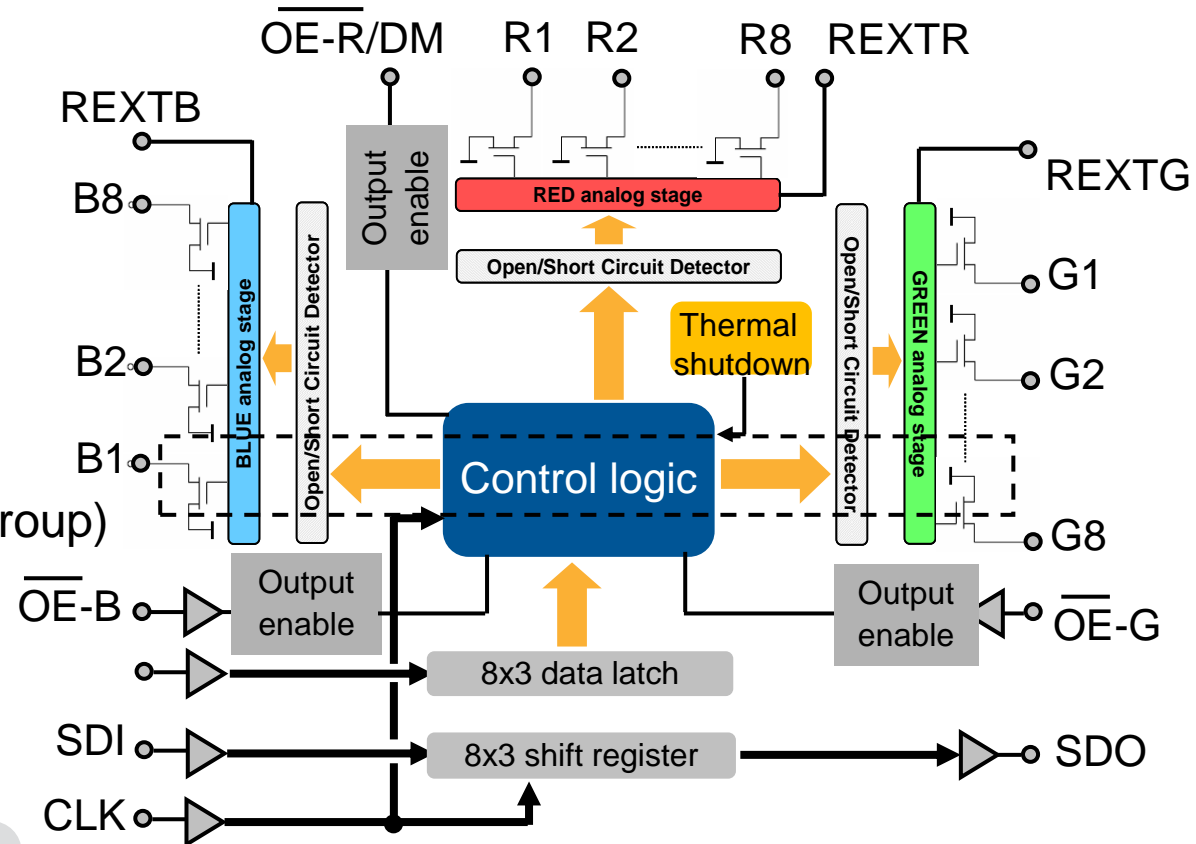

# HB RGB dimmer evaluation board



## Based on STP24DP05 and STM32F103C6

### Key features

- Two STP24DP05 (TQFP48) w/16 RGB high-brightness LEDs connected (48 LEDs in total)
- STM32 with cost-effective internal HS osc
- High-efficiency DC-DC switching power supply ST1S10 with input voltage range of 7.5 to 18 V, current 0.7 A
- Error detection feature/over-temperature flag
- Adjustable brightness
- JTAG interface for C firmware updates
- Mini USB connector for PC GUI connection
- Imp signal test points for lab evaluation
- Buttons and a knob to control the board
- 3 jumpers each for simulating disconnection and simulating shortage of 3 LEDs

### Key products

- STP24DP05
- STM32F103
- ST1S10

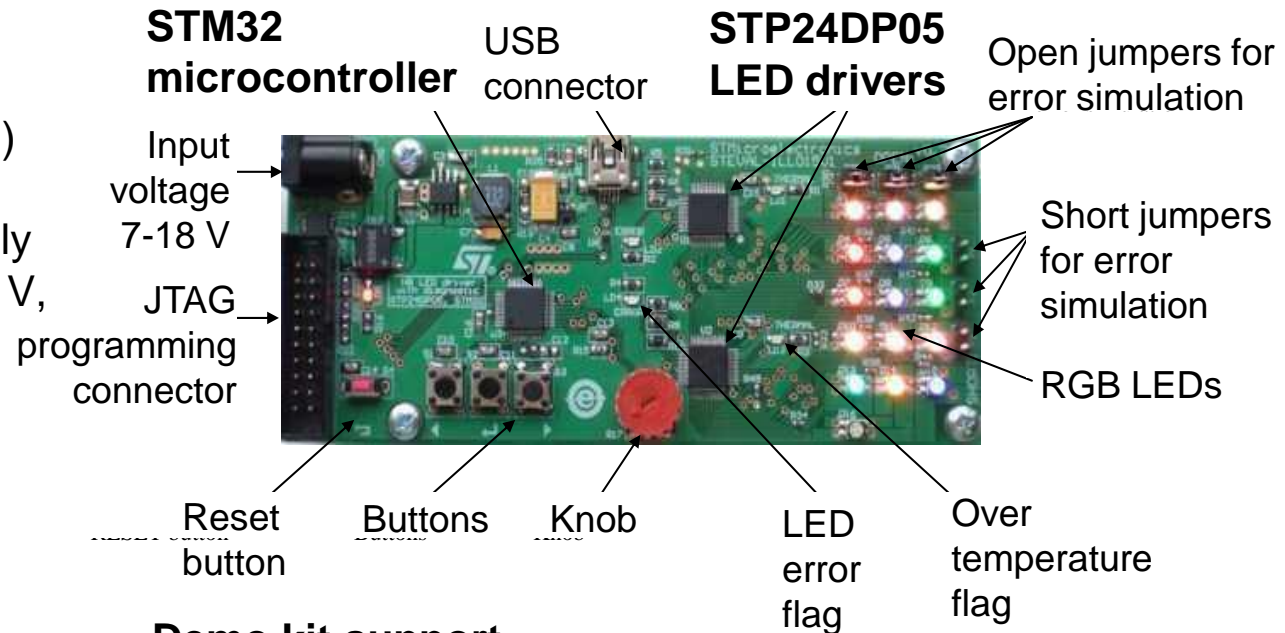

### Demo kit support

- STEVAL-ILL015V1 with Osram LEDs
- CD with user manual, application note, datasheets
- C library for dimming control of each individual LED
- Demo firmware and PC software
- Standalone: games, color dimming effects, error detection
- USB demo: error detection over USB

Evaluation board	App notes /user manuals	Description
STEVAL-ILL015V1	AN2841, UM0574, UM0588	High-brightness RGB LED array dimmer demo board based on the STP24DP05 and STM32

# Multicolor LED display panel eval board

- RGB moving message display system with STP24DP05 and STM32F103

## Key features

- Control unit with PS2 keyboard interface for data entry
- LCD on control unit for showing the display text and background color options
- 4x STP24DP05 for each display panel
- 8 panels can be cascaded in series through flat ribbon cable
- System configuration in typing data mode or in audio playback mode or in demo mode

## Key products

- STP24DP05 LED display driver
- STM32F103 32-bit microcontroller on control board
- STM1001 Reset IC
- STPS3L60 Schottky diode
- ST3232C 3 V RS-232 com interface

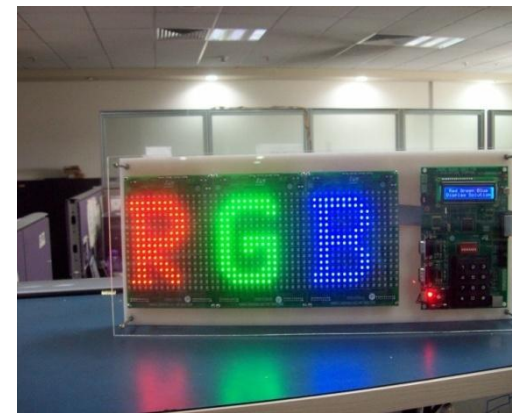

STEVAL-ILL032V1\*



STEVAL-ILL033V1\*

## Support

- Full-color display panels
- Airport and railway information system
- Bank currency conversion rate boards

Evaluation board	User manuals	Description
STEVAL-ILL032V1*, STEVAL-ILL033V1*	UM1449	STM32-based RGB LED matrix display demo

\* Available in Q4/2011

# LED array driver feature summary



Part number	#ch	I <sub>LED</sub> (mA)	ΔI <sub>LED</sub>		Error detect	Auto power saving	Balance turn on/off	Gray-scale Brightness control	Current gain adjustment	Staggered output delay
			Channel to channel (max)	IC to IC (max)						
STP08CP05	8	5 to 100	±3% (20 to 100 mA)	±6%						
STP08DP05	8	5 to 100	±3% (20 to 100 mA)	±6%	✓					
STP16CP05	16	5 to 100	±3% (20 to 100 mA)	±5%						
STP16CPS05	16	5 to 100	±3% (20 to 100 mA)	±5%		✓				
STP16DP05	16	5 to 100	±3% (20 to 100 mA)	±5%	✓					
STP16DPS05	16	5 to 100	±3% (20 to 100 mA)	±5%	✓	✓				
STP16CPP05	16	3 to 40	±3% (20 to 40 mA)	±5%						
STP16CPPS05	16	3 to 40	±3% (20 to 40 mA)	±5%		✓				
STP16DPP05	16	3 to 40	±3% (20 to 40 mA)	±5%	✓					
STP16DPPS05	16	3 to 40	±3% (20 to 40 mA)	±5%	✓	✓				
STP16CPC05	16	5 to 100	±3% (20 to 100 mA)	±5%			✓			
STP16CPC26	16	5 to 90	±3%	±6%			✓			
STP24DP05	24	5 to 80	±6% (5 to 15 mA) ±3% (15 to 80 mA)	±6%	✓					✓
STP1612PW05	16	3 to 60	±1.5% (3 to 60 mA)	±6%	✓			✓	✓	✓

# Array driver eval board summary



Part number	Order code	Description	Feature	App notes	Power supply
STP16CP05 STP16CPS05	STEVAL-ILL003V2	32 LED array reference board	<ul style="list-style-type: none"> <li>- Adjustable brightness, blinking speed</li> <li>- Animated text</li> <li>- GUI SW for LEDs diagnostics</li> </ul>	AN2241	Std supply connector
STP16DP05	STEVAL-ILL024V1 STEVAL-ILL025V1	Mother/slave board for LED display based on STM32 16x32 LED matrix	<ul style="list-style-type: none"> <li>- Animated text</li> <li>- Adjustable blinking speed</li> <li>- GPS interface</li> </ul>	UM0767	5 V, 0.5 A 3.5-5 V, 3 A
STP1612PW05	STEVAL-ILL028V1	RGB LED driver w/independent PWM for color display via STM32 SPI	<ul style="list-style-type: none"> <li>- Adjustable color</li> <li>- JTAG interface for C firmware update</li> </ul>	UM0882 UM0885	Std supply connector
STP08DP05	STEVAL-ILL002V3	40 LED diagnostic reference board using Osram blue LEDs	<ul style="list-style-type: none"> <li>- Adjustable brightness, blinking speed</li> <li>- Animated text</li> <li>- Error detection feature</li> </ul>	AN2415 AN2478	Std supply connector
STP08DP05	STEVAL-ILL002V4	40 LED diagnostic reference board using Vishay green LEDs	<ul style="list-style-type: none"> <li>- Adjustable brightness, blinking speed</li> <li>- Animated text</li> <li>- Error detection feature</li> </ul>	AN2415 AN2478	Std supply connector
STP24DP05	STEVAL-ILL015V1	16 RGB LED array based on STP24DP05 and STM32F103C6	<ul style="list-style-type: none"> <li>- Adjustable brightness</li> <li>- JTAG interface for C firmware update</li> <li>- Mini USB connector for PC GUI</li> <li>- Error detection feature</li> </ul>	UM0574	Std supply connector
STP24DP05	STEVAL-ILL032V1 STEVAL-ILL033V1	STM32-based RGB LED matrix display demo	<ul style="list-style-type: none"> <li>- Adjustable text color and speed</li> <li>- Adjustable background color</li> <li>- Audio playback mode</li> </ul>	UM1449	Std supply connector

# Using DC-DC switching regulators



- In driving LEDs

Monolithic solutions offer high efficiency and compactness, wide input voltage range, high current capability for a variety of applications, and high dimming performance for superior brightness uniformity

**LED770x**

**Boost for multi-row applications**

DC bus powered applications

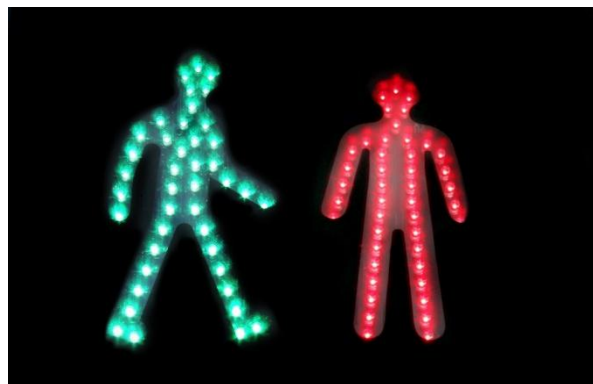

# Optimized LED driving solution



## ■ LED7706 and LED7707

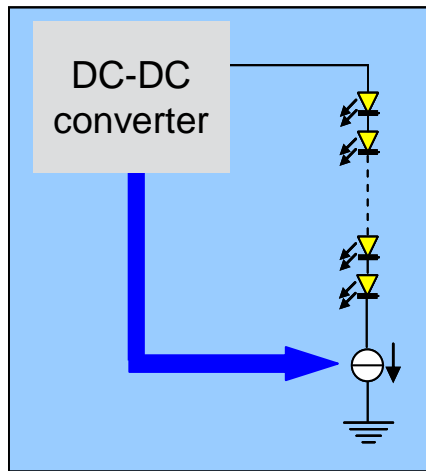

Serial

- ▲ Simpler architecture
- ▲ Brightness uniformity
- ▼ High voltage to manage

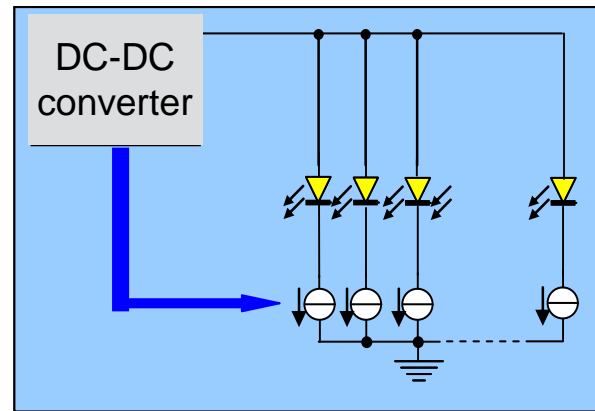

Parallel

- ▲ Low voltage
- ▼ High complexity due to current matching
- ▼ High power dissipation on current generators

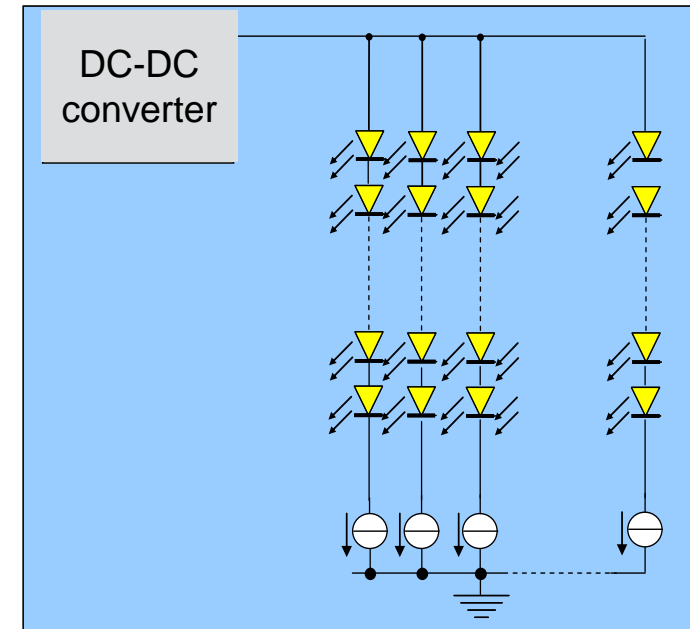

Multiple channel

LED770x trade-off based on:

- technology availability (rated voltage)
- efficiency
- LED current regulation

- Typical input bus available → 24 V
- LEDs to drive → up to 10 (e.g. considering 40 V technology)



Need for boost conversion

# LED7706/7: LED controllers



## Boost section

- 4.5 to 36 V input voltage range
- Internal +5 V LDO
- Internal power MOSFET
- Up to 93% efficiency
- Up to 36 V output voltage
- 200 kHz to 1 MHz switching frequency
- Fixed  $F_{SW}$  peak current mode control
- Programmable soft-start duration
- Programmable OV and OC protection
- Single ceramic output capacitor
- External sync for multi-device applications

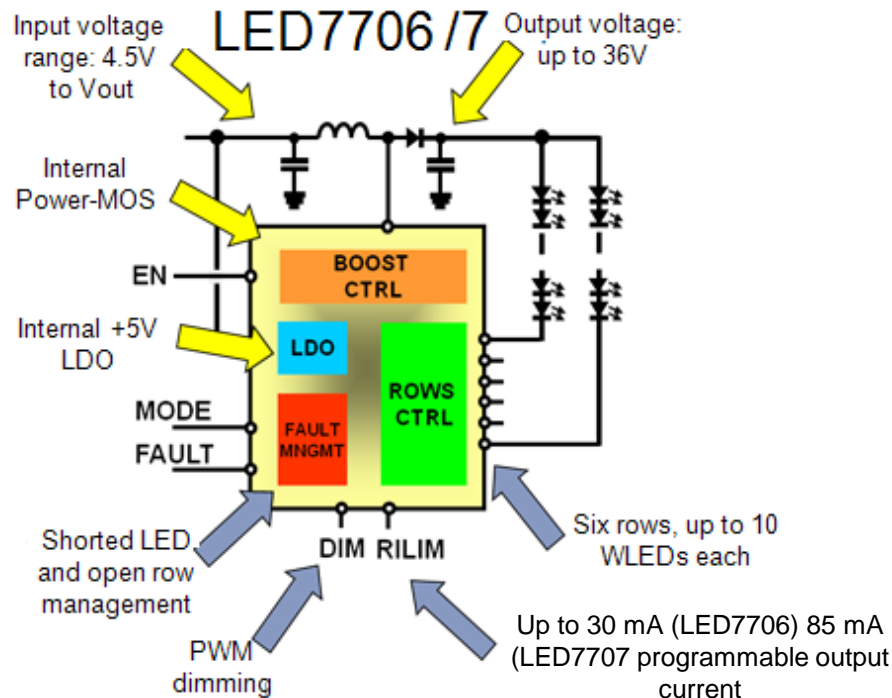

## Backlight driver section

- Six rows capable of driving multiple LEDs in series (e.g. up to ten WLEDs per row)
- Programmable output current per row
  - Up to 30 mA (LED7706)
  - Up to 85 mA (LED7707)
- PWM dimming
  - 500 ns minimum dimming on time (LED7706)
  - 10  $\mu$ s minimum dimming on time (LED7707)
- $\pm 2\%$  current matching between rows
- Shorted LED fault detection
- Open row fault detection
- Capability to disconnect unused rows

## Ideal for:

Industrial: traffic signals, lighting, displays

Industrial: mid- to large-size LCD TVs, MNT

Automotive: navigation displays and dashboards



# LED7706/7: adaptive output voltage



Fixed output voltage



$V_F$  spread

High power dissipation

Adaptive output voltage



Output voltage

depends on the active LED string  
with highest  $V_F$

Minimization of the power dissipation on  
the current generators

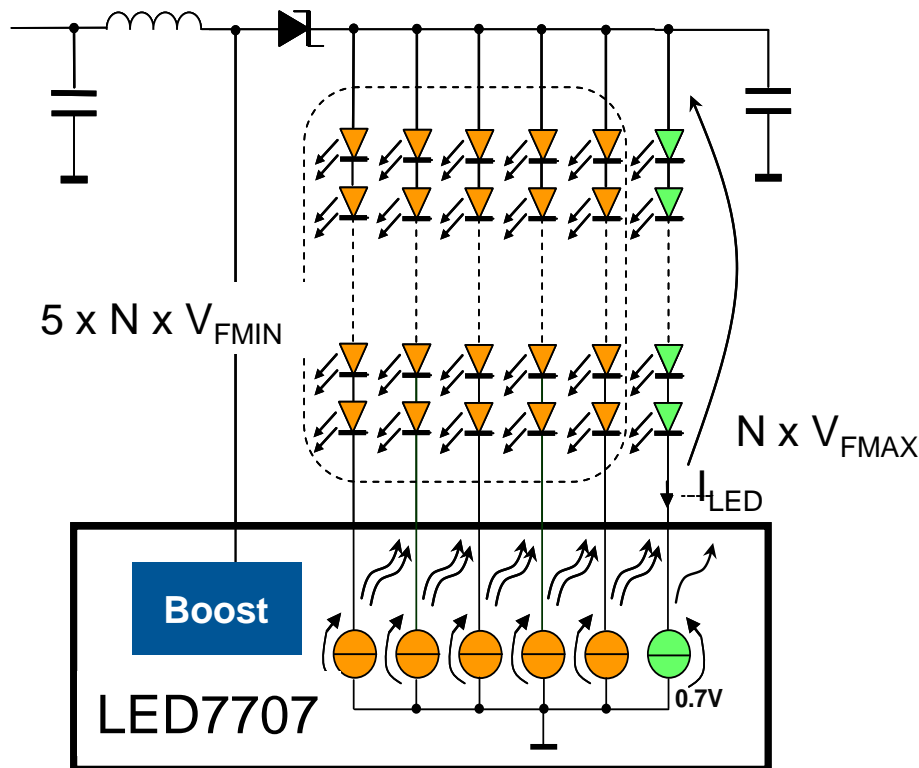

## Example

- $V_{IN} = 12\text{ V}$
- 6 strings of 8 LEDs
- $V_F, LED = 3.5 \pm 0.2\text{ V}$
- $f_{SW} = 600\text{ kHz}$
- $I_{ROW} = 75\text{ mA}$

$\eta = 84.2\%$  (fixed  $V_{OUT}$  approach)

$\eta = 87.3\%^*$  (adaptive  $V_{OUT}$  approach)

\*0.5% lower for every 100 mV increase in the voltage across the master generators

# LED7706/7: boost topology

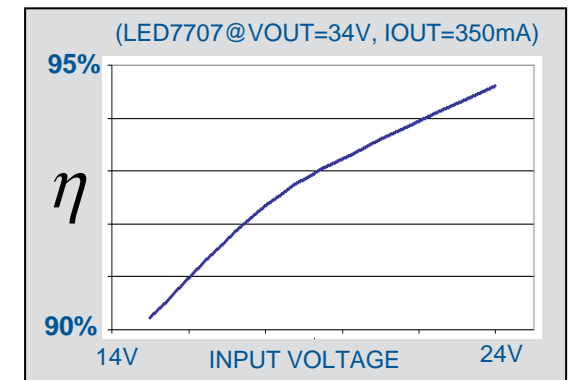
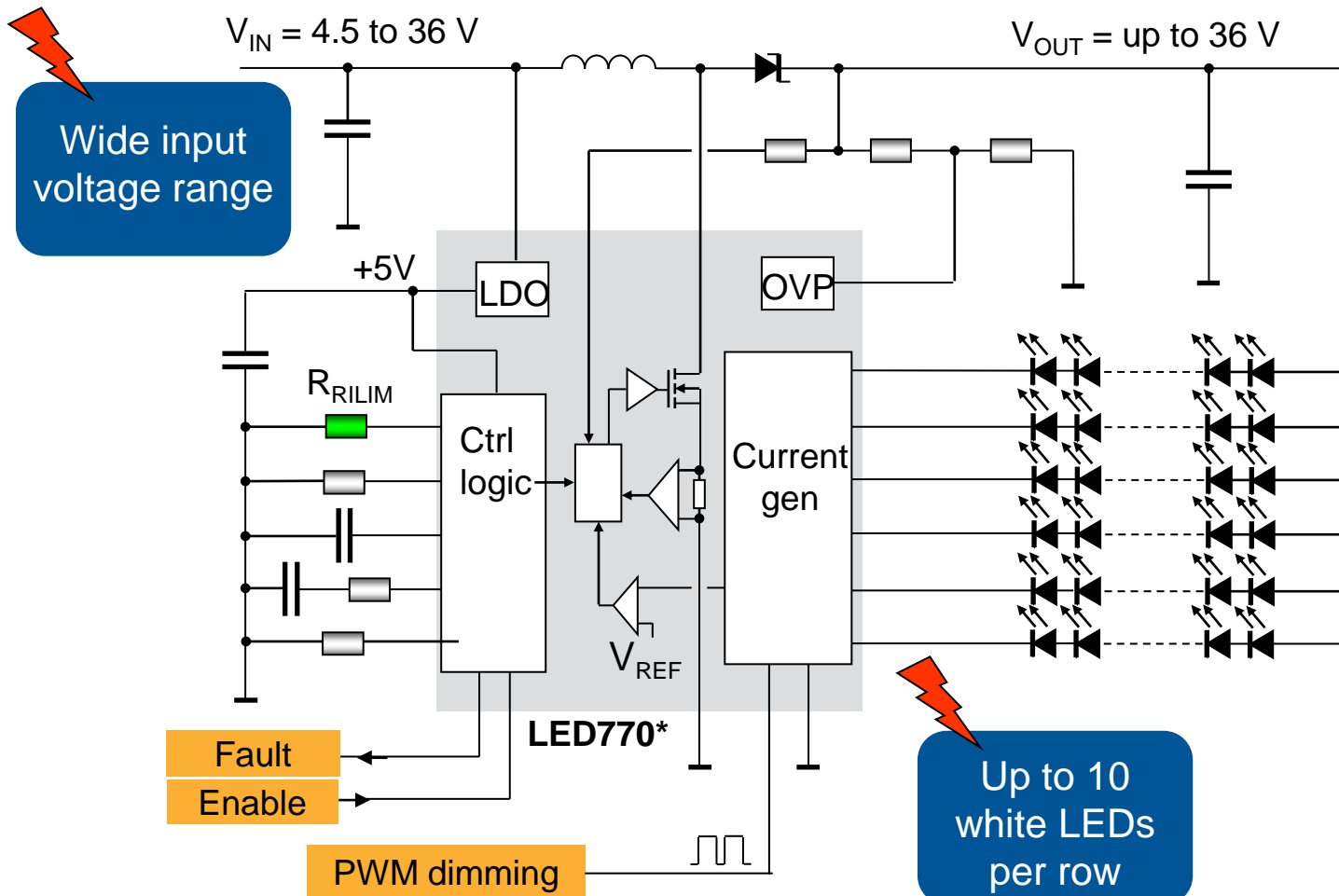

Input voltage: 4.5 to 36 V  
 Maximum RMS switch current: 2.5 A  
 Parallelable channels for higher current (LED7707)

LED current:  
 up to 85 mA/ch (LED7707)

$$I_{LED} = \frac{K_R}{R_{RILIM}}$$

Channel to channel current mismatch:  $\pm 2\%$   
 Up to 20 kHz PWM dimming (1% to 100%, LED7706)

# LED faults and dimming waveforms



1) Row0 opens

2) The output voltage increases

3) If 95% is crossed, the faulty row is disconnected

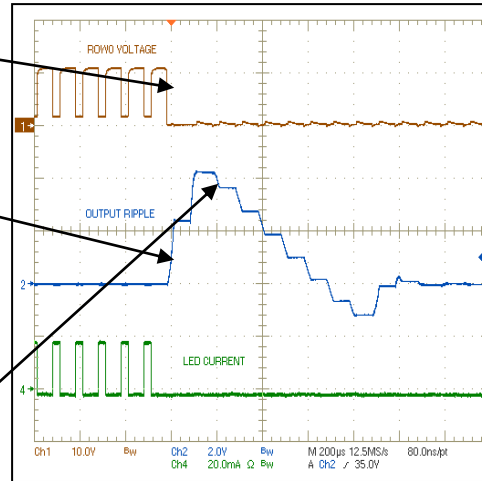

1) LED short circuit: Row0 voltage increases

2) If the 3.4 V threshold is crossed, the device is turned off (Mode = 0)

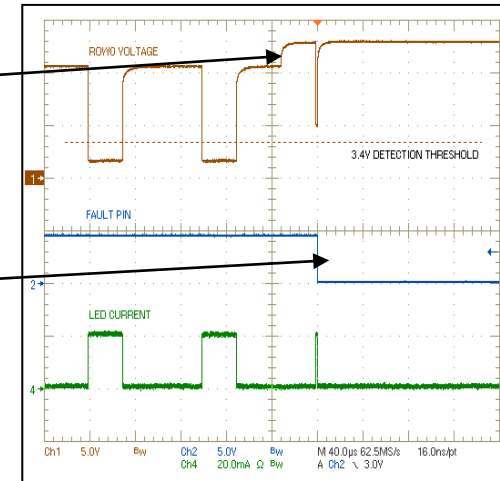

## Detecting and managing faults in LED7706/7

20  $\mu$ s dimming on-time

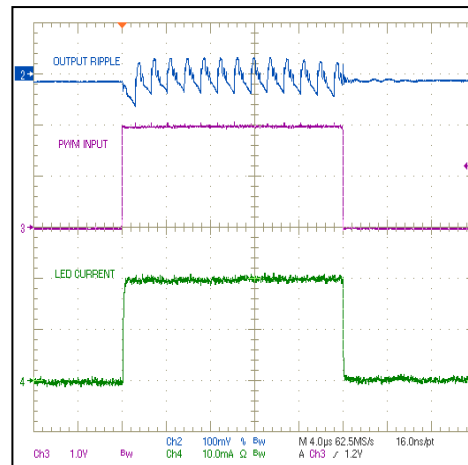

500 ns dimming on-time

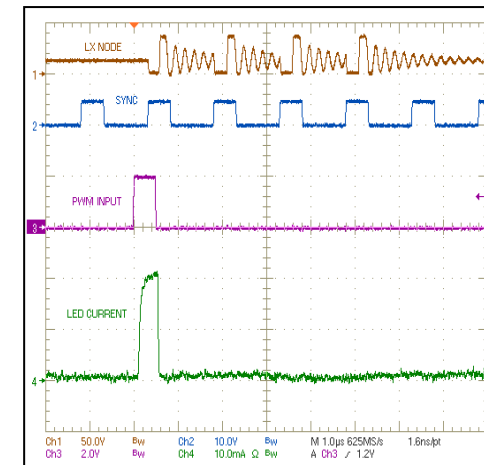

( $f_{DIM} = 10$  kHz,  $D_{DIM} = 20\%$ ,  $f_{SW} = 630$  kHz, LED current = 20 mA)

## Managing dimming waveforms in LED7706/7

# LED7706/7 LED driver application



## Examples

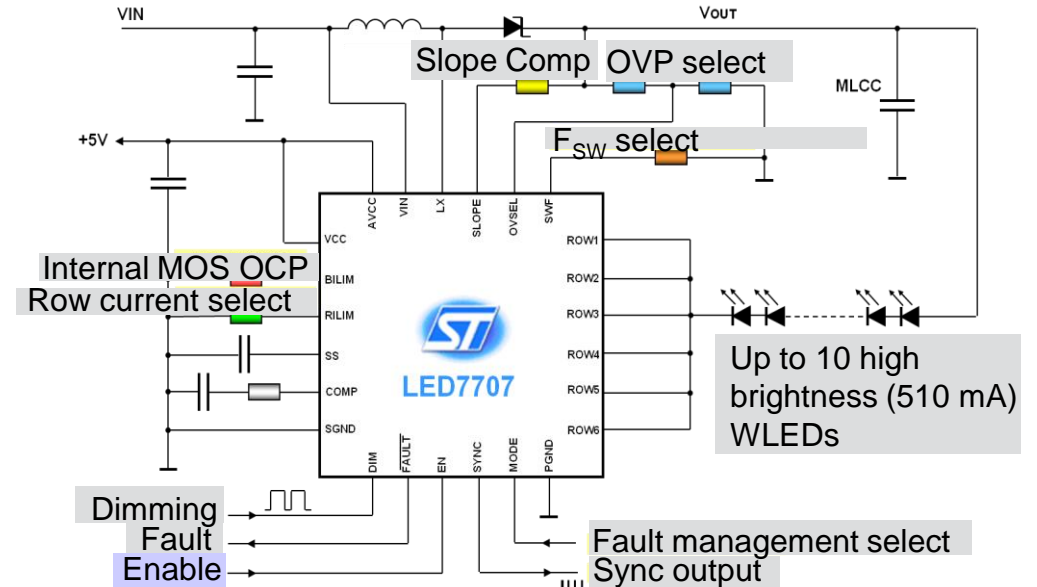
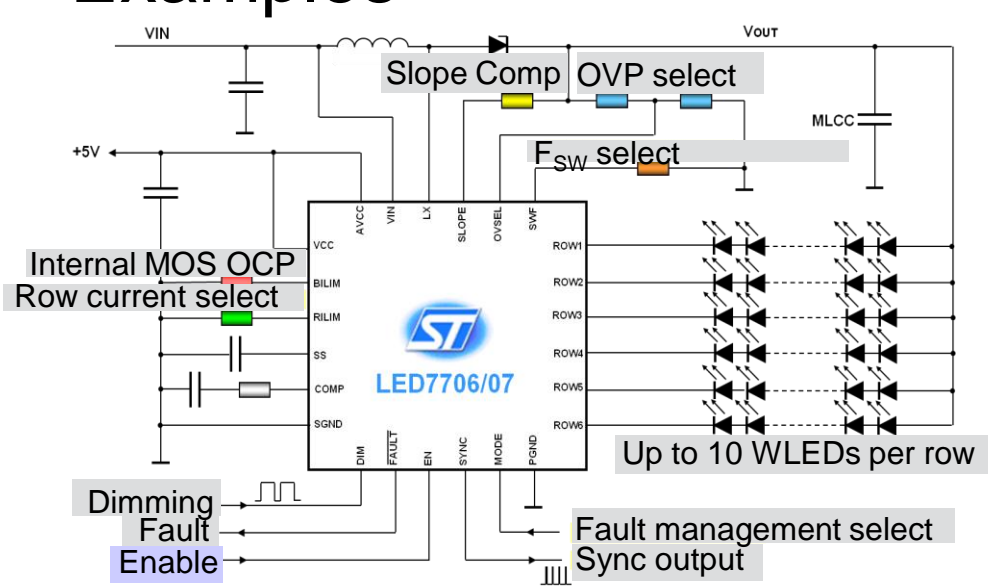

Typical application schematic

High-brightness LED driving solution

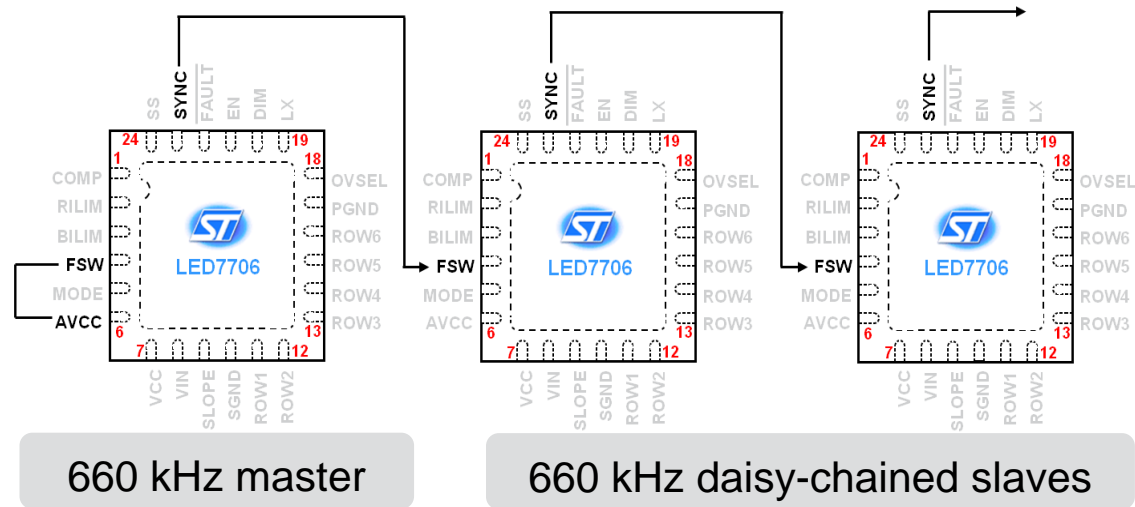

Multi-device applications with external synchronization

# LED driver w/boost converter solution



- Based on the LED7706 and LED7707

## Key features

### Boost section

- 4.5 to 36 V input voltage range
- Internal power MOSFET
- Internal +5 V LDO for device supply
- Up to 36 V output voltage
- Constant frequency peak current-mode control
- 200/250 kHz to 1 MHz adjustable switching frequency (LED7706/7)
- External sync for multi-device application
- Pulse-skip power saving mode at light load
- Programmable soft-start
- Programmable overvoltage protection
- Single ceramic output capacitor
- Non-latched thermal shutdown



STEVAL-ILL020V1



STEVAL-ILL021V1

### LED driver section

- Six rows with 30/85 mA maximum current capability (adjustable) LED7706/7
- Up to 10 white LEDs per row
- Rows disable option
- Less than 500 ns minimum dimming time (1% minimum dimming duty cycle at 20 kHz dimming frequency - LED7706,
- Less than 10  $\mu$ s minimum dimming time at 1 kHz dimming frequency - LED7707
- $\pm$ 2.0% current matching between rows
- LED failure (open and short circuit) detection

Part #	Evaluation board	Vin	Ioutmax	Description	App notes
LED7706	STEVAL-ILL020V1	4.5 to 36 V	20 mA per channel	LED driver with boost converter for LCD panel backlighting	AN2809
LED7707	STEVAL-ILL021V1	4.5 to 36 V	60 mA per channel	LED driver with boost converter for LCD panel backlighting	AN2810

## LED lighting brochure

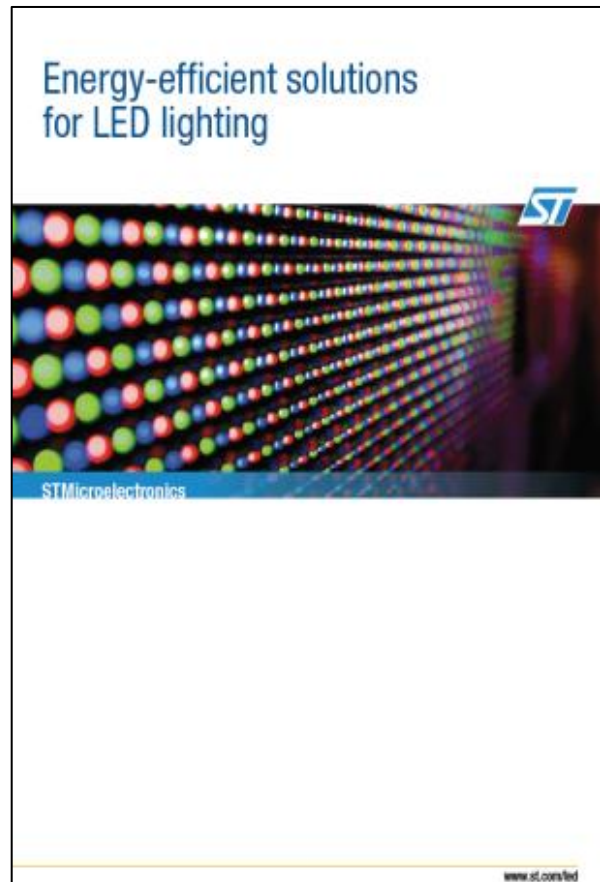

## LED application web pages

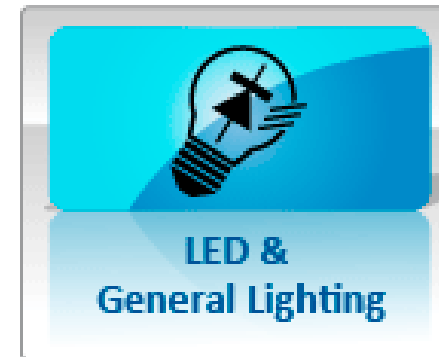

[http://www.st.com/internet/com/SALES\\_AND\\_MARKETING\\_RESOURCES/MARKETING\\_COMMUNICATION/MARKETING\\_BROCHURE/brlighting.pdf](http://www.st.com/internet/com/SALES_AND_MARKETING_RESOURCES/MARKETING_COMMUNICATION/MARKETING_BROCHURE/brlighting.pdf)

<http://www.st.com/internet/com/segment/412.jsp>

# Thank you



For more information, visit:

[www.st.com](http://www.st.com) > tools & resources

[www.st.com](http://www.st.com) > LED lighting