



STP62NS04Z

N-channel clamped 12.5mΩ - 62A - TO-220
Fully protected MESH OVERLAY™ Power MOSFET

General features

Type	V _{DSS} (@T _{jmax})	R _{DS(on)}	I _D
STP62NS04Z	Clamped	<0.015Ω	62A

- 100% avalanche tested
- Low capacitance and gate charge
- 175° C maximum junction temperature

Description

This fully clamped MOSFET is produced by using the latest advanced Company's Mesh Overlay process which is based on a novel strip layout. The inherent benefits of the new technology coupled with the extra clamping capabilities make this product particularly suitable for the harshest operation conditions such as those encountered in the automotive environment. Any other application requiring extra ruggedness is also recommended.

Applications

- Switching application

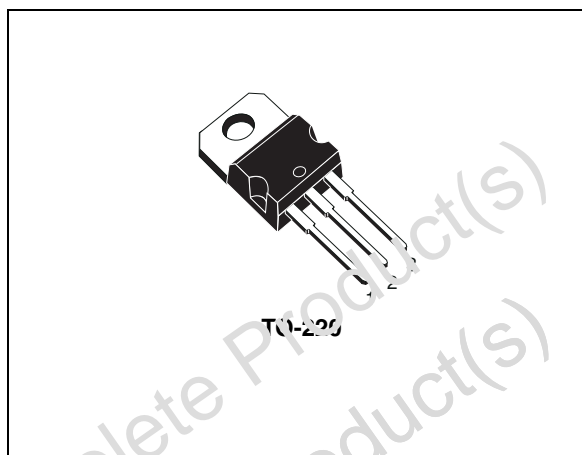

Internal schematic diagram

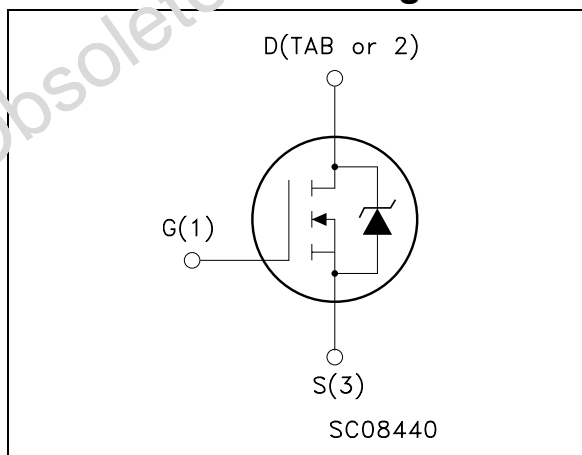

Order codes

Part number	Marking	Package	Packaging
STP62NS04Z	P62NS04Z	TO-220	Tube

Contents

1	Electrical ratings	3
2	Electrical characteristics	4
2.1	Electrical characteristics (curves)	6
3	Test circuit	8
4	Package mechanical data	9
5	Revision history	11

Obsolete Product(s) - Obsolete Product(s)
Obsolete Product(s) - Obsolete Product(s)

1 Electrical ratings

Table 1. Absolute maximum ratings

Symbol	Parameter	Value	Unit
V_{DS}	Drain-source voltage ($V_{GS} = 0$)	Clamped	V
V_{GS}	Gate-source voltage	Clamped	V
I_D	Drain current (continuous) at $T_C = 25^\circ\text{C}$	62	A
I_D	Drain current (continuous) at $T_C = 100^\circ\text{C}$	37.5	A
I_{DG}	Drain gate current (continuous)	± 50	
I_{GS}	Gate source current (continuous)	± 50	
$I_{DM}^{(1)}$	Drain current (pulsed)	248	A
P_{TOT}	Total dissipation at $T_C = 25^\circ\text{C}$	110	W
	Derating factor	0.74	W/ $^\circ\text{C}$
$dv/dt^{(2)}$	Peak diode recovery voltage slope	8	V/ns
$E_{AS}^{(3)}$	Single Pulse Avalanche Energy	500	mJ
V_{ESD}	ESD (HBM - C = 100pF, R = 1.5 k Ω)	8	V
T_J	Operating junction temperature	-55 to 175	$^\circ\text{C}$
T_{stg}	Storage temperature		

1. Pulse width limited by safe operating area
2. $I_{SD} \leq 40\text{A}$, $di/dt \leq 100\text{A}/\mu\text{s}$, $V_{DL} \leq (V_{BR})_{DSS}$, $T_J \leq T_{JMAX}$
3. Starting $T_J = 25^\circ\text{C}$, $I_D = 20\text{A}$, $V_{DD} = 20\text{V}$

Table 2 Thermal data

Symbol	Parameter	Value	Unit
R_{thJC}	Thermal resistance junction-case Max	1.36	$^\circ\text{C}/\text{W}$
R_{thJA}	Thermal resistance junction-ambient Max	62.5	$^\circ\text{C}/\text{W}$
T_I	Maximum lead temperature for soldering purpose	300	$^\circ\text{C}$

2 Electrical characteristics

(T_{CASE}=25°C unless otherwise specified)

Table 3. On/off states

Symbol	Parameter	Test conditions	Min.	Typ.	Max.	Unit
V _{(BR)DSS}	Drain-source breakdown voltage	I _D = 1mA, V _{GS} = 0	33			V
I _{DSS}	Zero gate voltage drain current (V _{GS} = 0)	V _{DS} = 16V			10	μA
I _{GSS}	Gate body leakage current (V _{DS} = 0)	V _{GS} = ±10V			10	μA
V _{GSS}	Gate-Source Breakdown Voltage	I _{GS} = 100 μA	18			V
V _{GS(th)}	Gate threshold voltage	V _{DS} = V _{GS} , I _D = 250μA	2		4	V
R _{DS(on)}	Static drain-source on resistance	V _{GS} = 10V, I _D = 30A		12.5	15	mΩ

Table 4. Dynamic

Symbol	Parameter	Test conditions	Min.	Typ.	Max.	Unit
g _{fs} ⁽¹⁾	Forward transconductance	V _{DS} = 15V, I _D = 30A		20		S
C _{iss}	Input capacitance	V _{DS} = 25V, f = 1 MHz, V _{GS} = 0		1330		pF
C _{oss}	Output capacitance			420		pF
C _{rss}	Reverse transfer capacitance			135		pF
Q _g	Total gate charge	V _{DD} = 20V, I _D = 40A V _{GS} = 10V		34	47	nC
Q _{gs}	Gate-source charge			10		nC
Q _{gd}	Gate-drain charge			11.5		nC

1. Pulsed: pulse duration=300μs, duty cycle 1.5%

Table 5. Switching times

Symbol	Parameter	Test conditions	Min.	Typ.	Max.	Unit
t _{d(on)}	Turn-on delay time	V _{DD} = 20V, I _D = 20A, R _G = 4.7Ω, V _{GS} = 10V <i>Figure 13 on page 8</i>		13		ns
t _r	Rise time			104		ns
t _{d(off)}	Turn-off delay time			41		ns
t _f	Fall time			42		ns
t _{r(Voff)}	Off-voltage rise time	V _{clamp} = 30V, I _D = 40A R _G = 4.7Ω, V _{GS} = 10V <i>Figure 13 on page 8</i>		30		ns
t _f	Fall time			54		ns
t _c	Cross-over time			90		ns

Table 6. Source drain diode

Symbol	Parameter	Test conditions	Min	Typ.	Max	Unit
I_{SD}	Source-drain current				62	A
$I_{SDM}^{(1)}$	Source-drain current (pulsed)				248	A
$V_{SD}^{(2)}$	Forward on voltage	$I_{SD} = 62A, V_{GS} = 0$			1.5	V
t_{rr}	Reverse recovery time	$I_{SD} = 40A,$ $di/dt = 100A/\mu s,$ $V_{DD} = 20V, T_J = 150^\circ C$ <i>Figure 15 on page 8</i>		45		ns
Q_{rr}	Reverse recovery charge			65		μC
I_{RRM}	Reverse recovery current			2.9		A

1. Pulse width limited by safe operating area
2. Pulsed: pulse duration=300 μs , duty cycle 1.5%

2.1 Electrical characteristics (curves)

Figure 1. Safe operating area

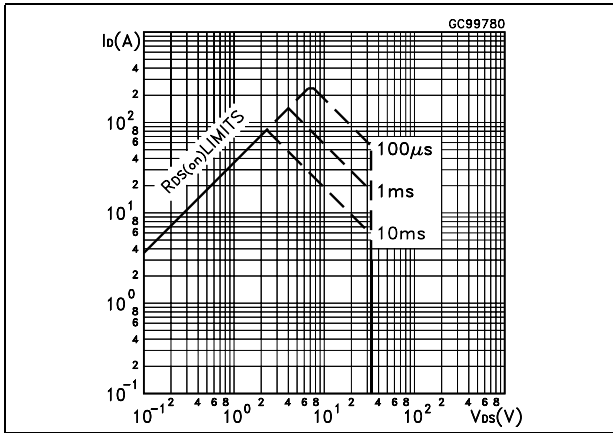

Figure 2. Thermal impedance

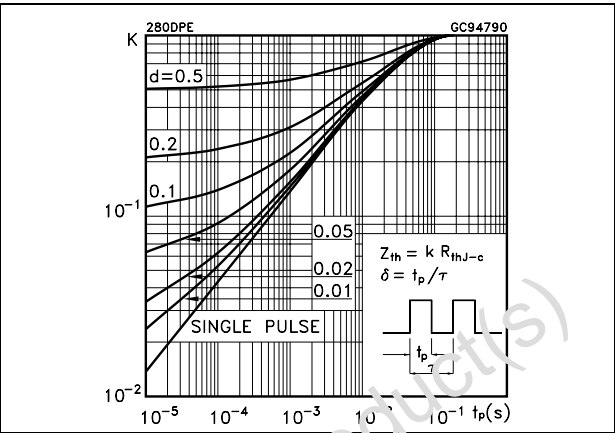

Figure 3. Output characteristics

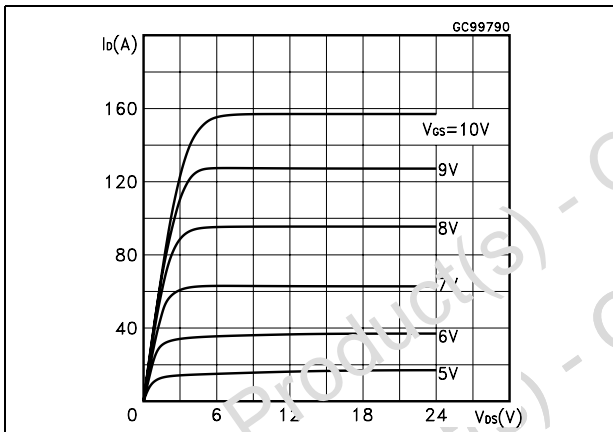

Figure 4. Transfer characteristics

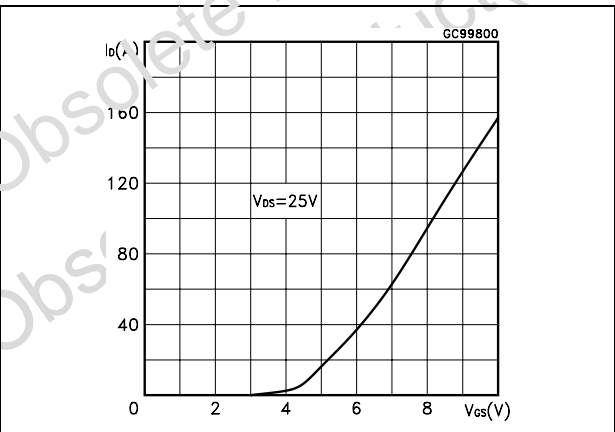

Figure 5. Transconductance

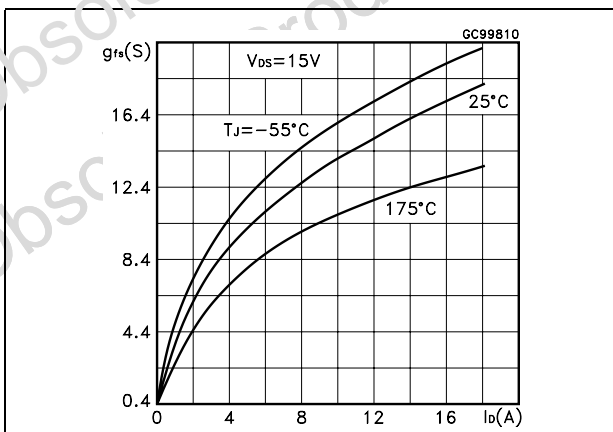

Figure 6. Static drain-source on resistance

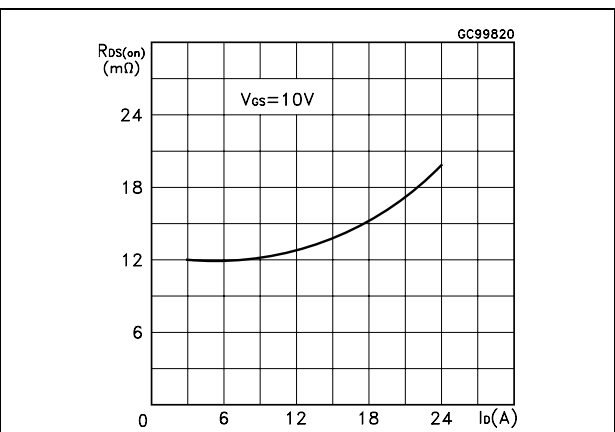

Figure 7. Gate charge vs gate-source voltage Figure 8. Capacitance variations

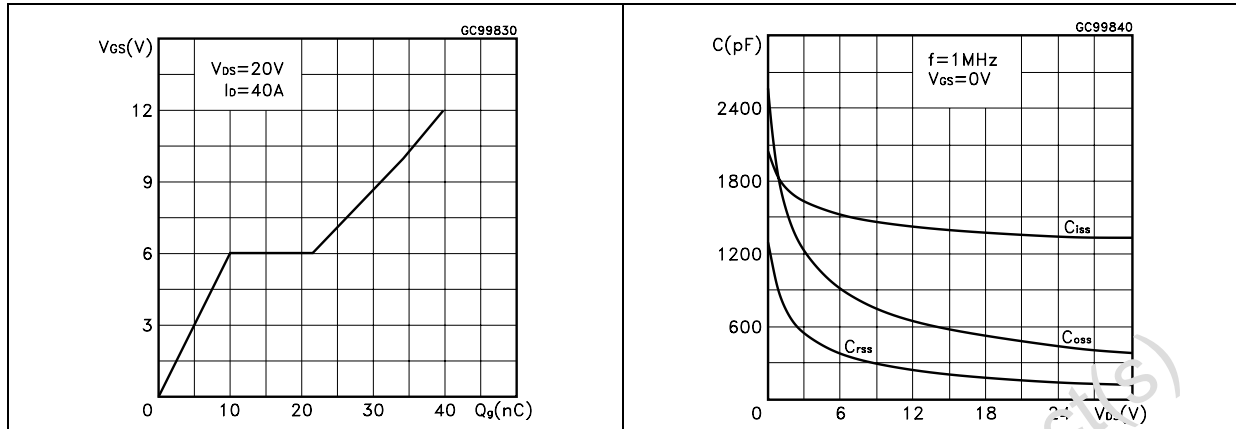

Figure 9. Normalized gate threshold voltage vs temperature Figure 10. Normalized on resistance vs temperature

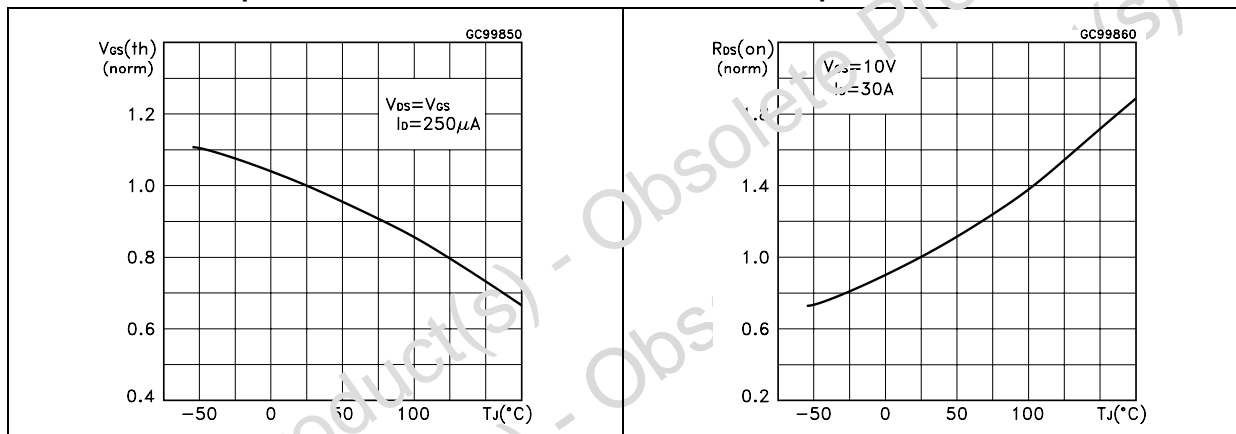
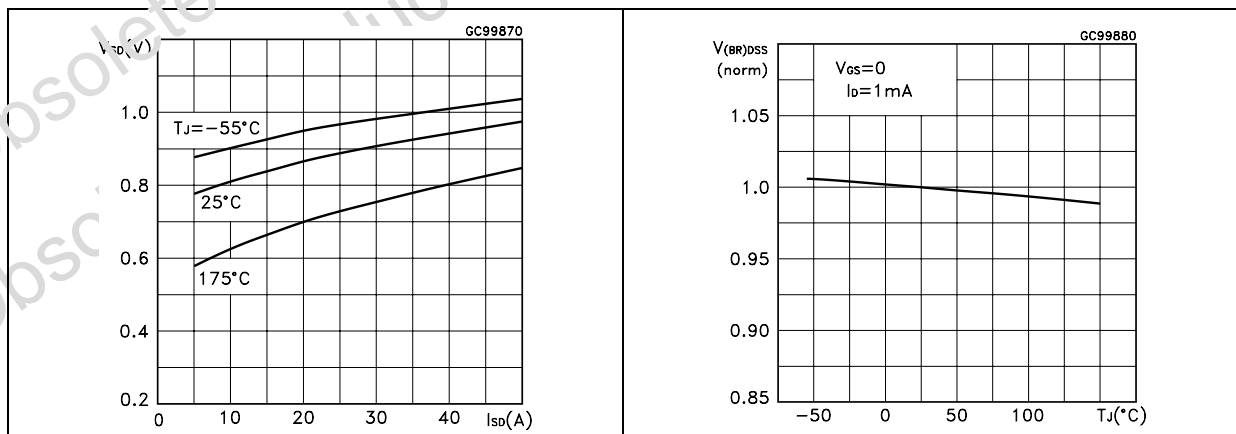

Figure 11. Source-drain diode forward characteristics Figure 12. Normalized $B_{V_{DSS}}$ vs temperature



3 Test circuit

Figure 13. Switching times test circuit for resistive load

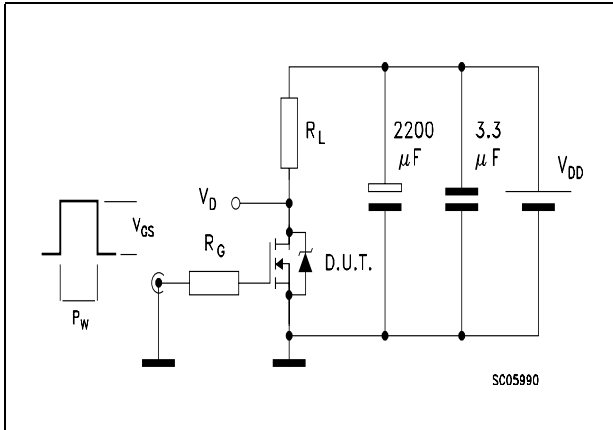

Figure 14. Gate charge test circuit

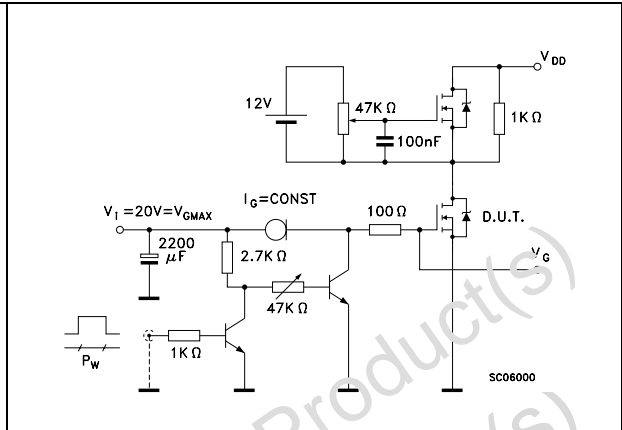

Figure 15. Test circuit for inductive load switching and diode recovery times

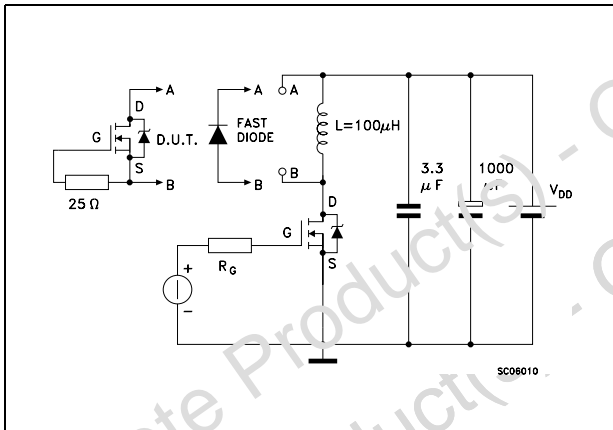

Figure 16. Unclamped Inductive load test circuit

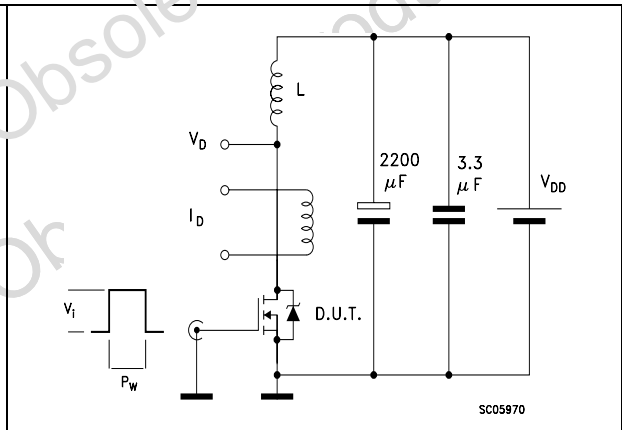
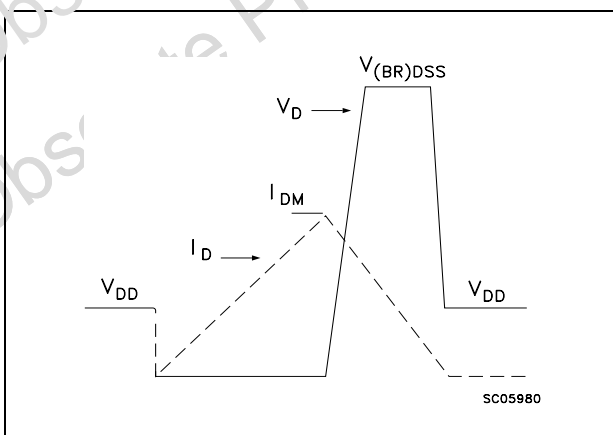

Figure 17. Unclamped inductive waveform



4 Package mechanical data

In order to meet environmental requirements, ST offers these devices in ECOPACK® packages. These packages have a Lead-free second level interconnect . The category of second level interconnect is marked on the package and on the inner box label, in compliance with JEDEC Standard JESD97. The maximum ratings related to soldering conditions are also marked on the inner box label. ECOPACK is an ST trademark. ECOPACK specifications are available at: www.st.com

Obsolete Product(s) - Obsolete Product(s)
Obsolete Product(s) - Obsolete Product(s)

TO-220 MECHANICAL DATA

DIM.	mm.			inch		
	MIN.	TYP.	MAX.	MIN.	TYP.	MAX.
A	4.40		4.60	0.173		0.181
b	0.61		0.88	0.024		0.034
b1	1.15		1.70	0.045		0.066
c	0.49		0.70	0.019		0.027
D	15.25		15.75	0.60		0.620
E	10		10.40	0.393		0.409
e	2.40		2.70	0.094		0.106
e1	4.95		5.15	0.194		0.202
F	1.23		1.32	0.048		0.052
H1	6.20		6.60	0.244		0.256
J1	2.40		2.72	0.094		0.107
L	13		14	0.511		0.551
L1	3.50		3.93	0.137		0.154
L20		16.40			0.645	
L30		28.90			1.137	
øP	3.75		3.35	0.147		0.151
Q	2.65		2.95	0.104		0.116

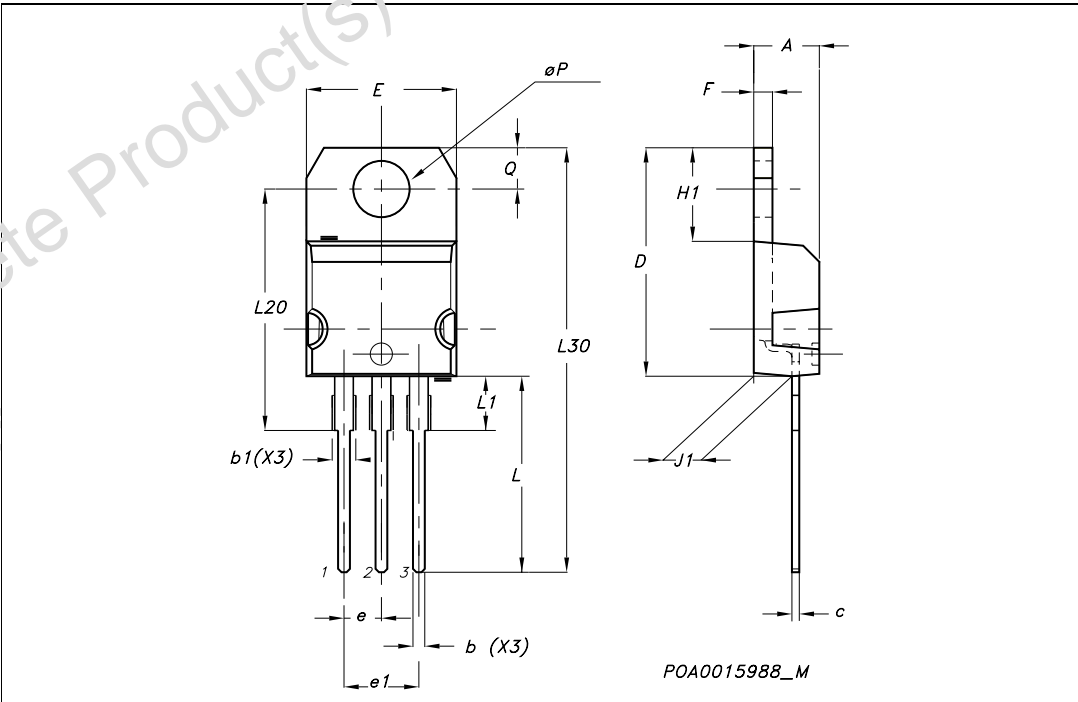

5 Revision history

Table 7. Revision history

Date	Revision	Changes
21-Jun-2004	2	Preliminary datasheet
22-Aug-2005	3	Complete document with curves
21-Jan-2006	4	New ECOPAK label
02-Oct-2006	5	New template, no content change

Obsolete Product(s) - Obsolete Product(s)
Obsolete Product(s) - Obsolete Product(s)

Please Read Carefully:

Information in this document is provided solely in connection with ST products. STMicroelectronics NV and its subsidiaries ("ST") reserve the right to make changes, corrections, modifications or improvements, to this document, and the products and services described herein at any time, without notice.

All ST products are sold pursuant to ST's terms and conditions of sale.

Purchasers are solely responsible for the choice, selection and use of the ST products and services described herein, and ST assumes no liability whatsoever relating to the choice, selection or use of the ST products and services described herein.

No license, express or implied, by estoppel or otherwise, to any intellectual property rights is granted under this document. If any part of this document refers to any third party products or services it shall not be deemed a license grant by ST for the use of such third party products or services, or any intellectual property contained therein or considered as a warranty covering the use in any manner whatsoever of such third party products or services or any intellectual property contained therein.

UNLESS OTHERWISE SET FORTH IN ST'S TERMS AND CONDITIONS OF SALE ST DISCLAIMS ANY EXPRESS OR IMPLIED WARRANTY WITH RESPECT TO THE USE AND/OR SALE OF ST PRODUCTS INCLUDING WITHOUT LIMITATION IMPLIED WARRANTIES OF MERCHANTABILITY, FITNESS FOR A PARTICULAR PURPOSE (AND THEIR EQUIVALENTS UNDER THE LAWS OF ANY JURISDICTION), OR INFRINGEMENT OF ANY PATENT, COPYRIGHT OR OTHER INTELLECTUAL PROPERTY RIGHT.

UNLESS EXPRESSLY APPROVED IN WRITING BY AN AUTHORIZED ST REPRESENTATIVE, ST PRODUCTS ARE NOT RECOMMENDED, AUTHORIZED OR WARRANTED FOR USE IN MILITARY, AIR CRAFT, SPACE, LIFE SAVING, OR LIFE SUSTAINING APPLICATIONS, NOR IN PRODUCTS OR SYSTEMS WHERE FAILURE OR MALFUNCTION MAY RESULT IN PERSONAL INJURY, DEATH, OR SEVERE PROPERTY OR ENVIRONMENTAL DAMAGE. ST PRODUCTS WHICH ARE NOT SPECIFIED AS "AUTOMOTIVE GRADE" MAY ONLY BE USED IN AUTOMOTIVE APPLICATIONS AT USER'S OWN RISK.

Resale of ST products with provisions different from the statements and/or technical features set forth in this document shall immediately void any warranty granted by ST for the ST product or service described herein and shall not create or extend in any manner whatsoever, any liability of ST.

ST and the ST logo are trademarks or registered trademarks of ST in various countries.

Information in this document supersedes and replaces all information previously supplied.

The ST logo is a registered trademark of STMicroelectronics. All other names are the property of their respective owners.

© 2006 STMicroelectronics - All rights reserved

STMicroelectronics group of companies

Australia - Belgium - Brazil - Canada - China - Czech Republic - Finland - France - Germany - Hong Kong - India - Israel - Italy - Japan - Malaysia - Malta - Morocco - Singapore - Spain - Sweden - Switzerland - United Kingdom - United States of America

www.st.com