



M40Z300AV

3V NVRAM Supervisor for Up to 8 LPSRAMs

FEATURES SUMMARY

- CONVERTS LOW POWER SRAM INTO NVRAMs
- PRECISION POWER MONITORING AND POWER SWITCHING CIRCUITRY
- AUTOMATIC WRITE-PROTECTION WHEN V_{CC} IS OUT-OF-TOLERANCE
- TWO-INPUT DECODER ALLOWS CONTROL FOR UP TO 8 SRAMs (with 2 devices active in parallel)
- SUPPLY VOLTAGE AND POWER-FAIL DESELECT VOLTAGE:
 - M40Z300AV:
 - $V_{CC} = 3.0V$ to $3.6V$
 - $THS = V_{SS}$: $2.8V \leq V_{PFD} \leq 3.0V$
- RESET OUTPUT (\overline{RST}) FOR POWER ON RESET
- BATTERY LOW PIN (\overline{BL})
- LESS THAN 20ns CHIP ENABLE ACCESS PROPAGATION DELAY
- PACKAGING INCLUDES A 16-LEAD SOIC OR A 28-LEAD SOIC AND SNAPHAT[®] TOP (to be ordered separately)
- SOIC PACKAGE PROVIDES DIRECT CONNECTION FOR A SNAPHAT TOP WHICH CONTAINS THE BATTERY

Figure 1. 16-pin SOIC Package

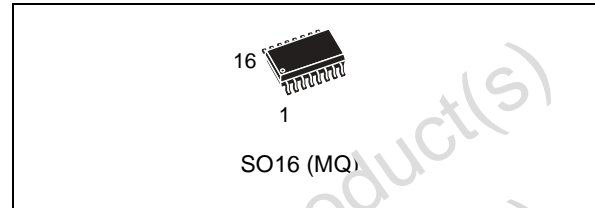

Figure 2. 28-pin SOIC Package*

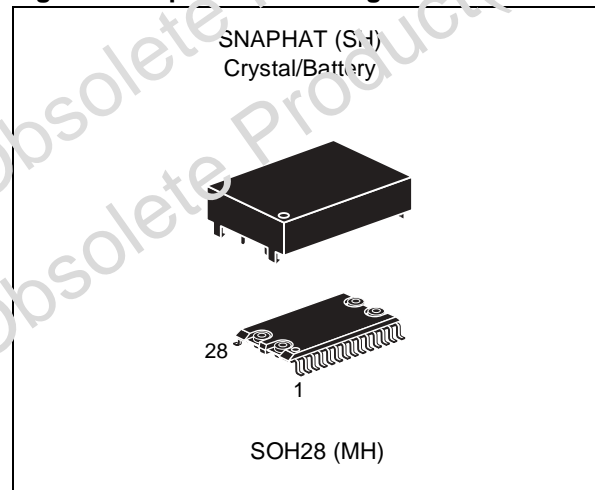

TABLE OF CONTENTS

FEATURES SUMMARY 1

 Figure 1. 16-pin SOIC Package 1

 Figure 2. 28-pin SOIC Package* 1

DESCRIPTION 4

 Figure 3. Logic Diagram 4

 Table 1. Signal Names 4

 Figure 4. 28-pin SOIC Connections 5

 Figure 5. M40Z300AV 16-pin SOIC Connections 5

 Figure 6. Hardware Hookup 5

OPERATION 6

Two to Four Decode 6

 Table 2. Truth Table 6

 Figure 7. Address-Decode Time 6

Data Retention Lifetime Calculation 7

Power-on Reset Output 7

Battery Low Pin 7

V_{CC} Noise And Negative Going Transients 8

 Figure 8. Supply Voltage Protection 8

MAXIMUM RATING 9

 Table 3. Absolute Maximum Ratings 9

DC AND AC PARAMETERS 10

 Table 4. DC and AC Measurement Conditions 10

 Figure 9. AC Testing Load Circuit 10

 Table 5. Capacitance 10

 Table 6. DC Characteristics 11

 Figure 10. Power Down Timing 12

 Figure 11. Power Up Timing 12

 Table 7. Power Down/Up Mode AC Characteristics 13

PACKAGE MECHANICAL INFORMATION 14

 Figure 12. SOH28 – 28-lead Plastic Small Outline, 4-socket battery SNAPHAT, Package Outline. 14

 Table 8. SOH28 – 28-lead Plastic Small Outline, battery SNAPHAT, Package Mechanical Data 14

 Figure 13. SH – 4-pin SNAPHAT Housing for 48mAh Battery, Package Outline 15

 Table 9. SH – 4-pin SNAPHAT Housing for 48mAh Battery, Package Mechanical Data 15

 Figure 14. SH – 4-pin SNAPHAT Housing for 120mAh Battery, Package Outline 16

 Table 10. SH – 4-pin SNAPHAT Housing for 120mAh Battery, Package Mechanical Data 16

 Figure 15. SO16 – 16-lead Plastic Small Outline, 150 mils body width, Package Outline 17

 Table 11. SO16 – 16-lead Plastic Small Outline, 150 mils body width, Package Mechanical Data 17

PART NUMBERING	18
Table 12. Ordering Information Example.....	18
Table 13. SNAPHAT® Battery Table.....	18
REVISION HISTORY	19
Table 14. Document Revision History	19

Obsolete Product(s) - Obsolete Product(s)
Obsolete Product(s) - Obsolete Product(s)

DESCRIPTION

The M40Z300AV NVRAM SUPERVISOR is a self-contained device which converts a standard low-power SRAM into a non-volatile memory. A precision voltage reference and comparator monitors the V_{CC} input for an out-of-tolerance condition.

When an invalid V_{CC} condition occurs, the conditioned chip enable outputs ($\overline{E1CON}$ to $\overline{E4CON}$) are forced inactive to write-protect the stored data in the SRAM. During a power failure, the SRAM is switched from the V_{CC} pin to the lithium cell within the SNAPHAT[®] to provide the energy required for data retention. On a subsequent power-up, the SRAM remains write protected until a valid power condition returns.

The 28-pin, 330mil SOIC provides sockets with gold plated contacts for direct connection to a separate SNAPHAT housing containing the battery. The SNAPHAT housing has gold plated pins which mate with the sockets, ensuring reliable connection. The housing is keyed to prevent improper insertion. This unique design allows the SNAPHAT battery package to be mounted on top

of the SOIC package after the completion of the surface mount process which greatly reduces the board manufacturing process complexity of either directly soldering or inserting a battery into a soldered holder. Providing non-volatility becomes a "SNAP." The 16-pin SOIC provides battery pins for an external user-supplied battery.

Insertion of the SNAPHAT housing after reflow prevents potential battery damage due to the high temperatures required for device surface-mounting. The SNAPHAT housing is also keyed to prevent reverse insertion.

The 28-pin SOIC and battery packages are shipped separately in plastic anti-static tubes or in Tape & Reel form. For the 28-lead SOIC, the battery/crystal package (e.g., SNAPHAT) part number is "M4ZXX-BR005n" (see Table 13., page 18).

Caution: Do not place the SNAPHAT battery top in conductive foam, as this will drain the lithium button-cell battery.

Figure 3. Logic Diagram

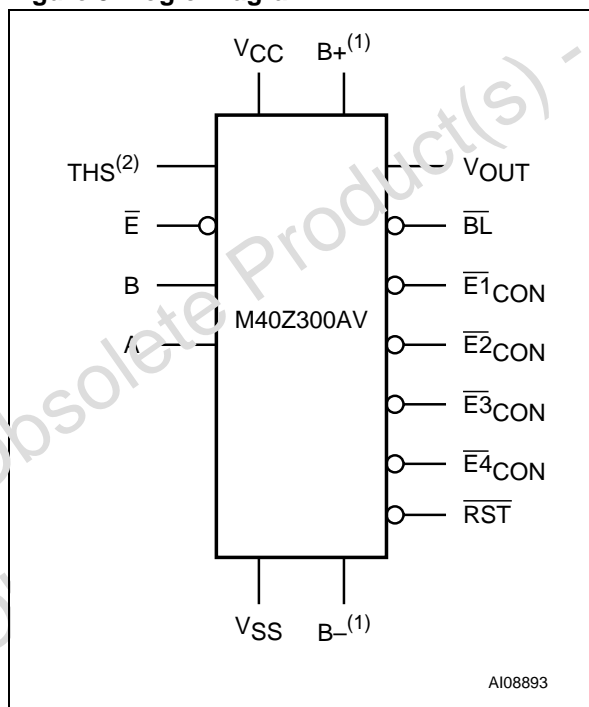

Note: 1. For 16-pin SOIC package only.
 2. THS pin must be connected to V_{SS}.

Table 1. Signal Names

THS ⁽¹⁾	Threshold Select Input
\overline{E}	Chip Enable Input
$\overline{E1CON} - \overline{E4CON}$	Conditioned Chip Enable Output
A, B	Decoder Inputs
\overline{RST}	Reset Output (Open Drain)
\overline{BL}	Battery Low Output (Open Drain)
V _{OUT}	Supply Voltage Output
V _{CC}	Supply Voltage
V _{SS}	Ground
B +	Positive Battery Pin
B -(²)	Negative Battery Pin
NC	Not Connected Internally

Note: 1. THS pin must be connected to V_{SS}.
 2. For M40Z300AV, B- must be connected to the negative battery terminal only (not to Pin 8, V_{SS}).

Figure 4. 28-pin SOIC Connections

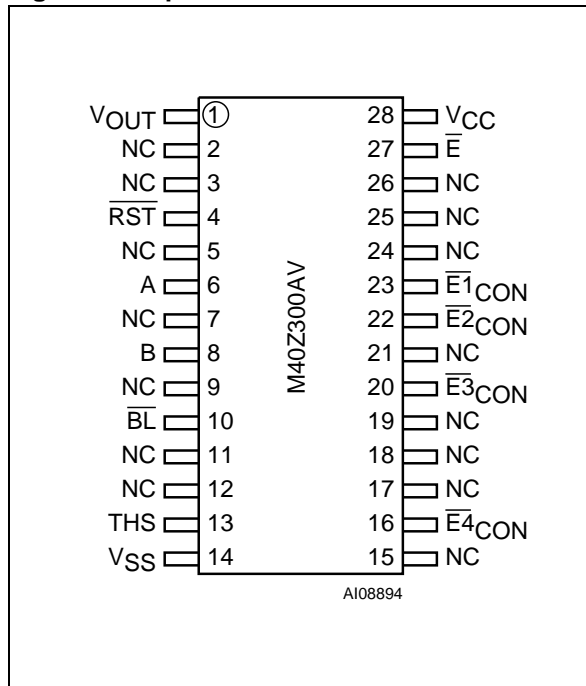
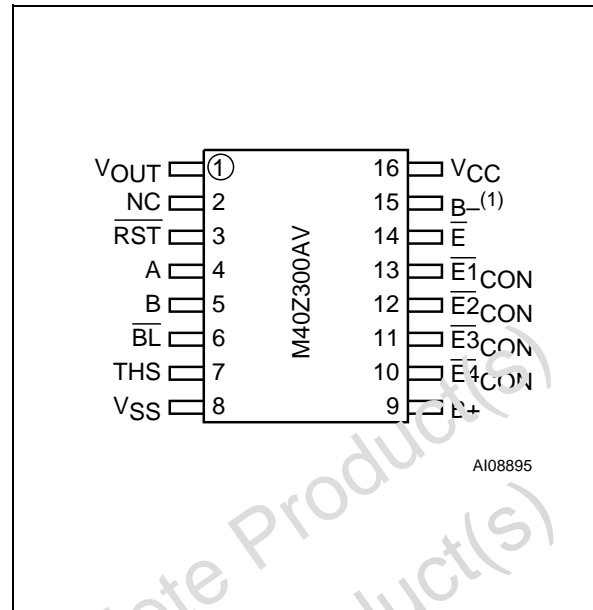
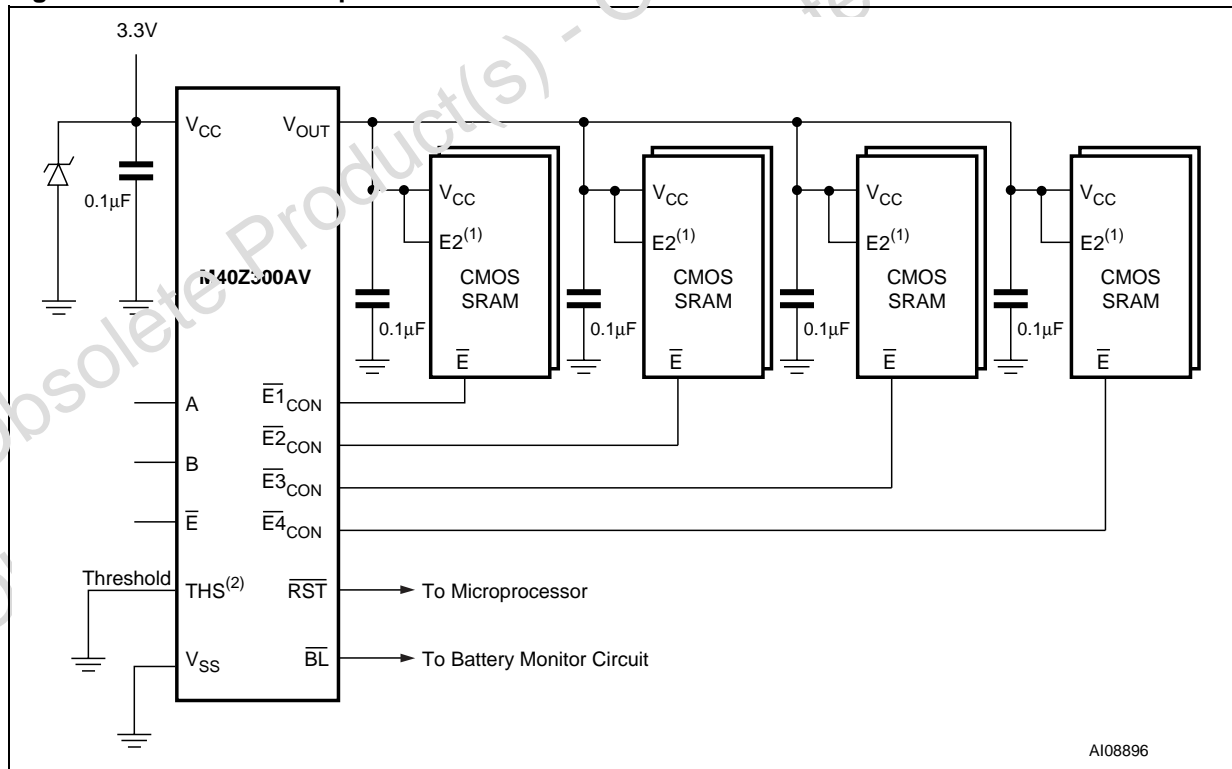

Figure 5. M40Z300AV 16-pin SOIC Connections



Note: 1. For M40Z300AV, B- must be connected to the negative battery terminal only (not to Pin 8, VSS).

Figure 6. Hardware Hookup



Note: 1. If the second chip enable pin (E2) is unused, it should be tied to V_{OUT}.
 2. THS pin must be connected to V_{SS}.

OPERATION

The M40Z300AV, as shown in Figure 6., page 5, can control up to four (eight, if placed in parallel) standard low-power SRAMs. These SRAMs must be configured to have the chip enable input disable all other input signals. Most slow, low-power SRAMs are configured like this, however many fast SRAMs are not. During normal operating conditions, the conditioned chip enable ($\overline{E1CON}$ to $\overline{E4CON}$) output pins follow the chip enable (\overline{E}) input pin with timing shown in Figure 7., page 6 and Table 7., page 13. An internal switch connects V_{CC} to V_{OUT} . This switch has a voltage drop of less than 0.3V (I_{OUT1}).

When V_{CC} degrades during a power failure, $\overline{E1CON}$ to $\overline{E4CON}$ are forced inactive independent of \overline{E} . In this situation, the SRAM is unconditionally write protected as V_{CC} falls below an out-of-tolerance threshold (V_{PFD}). For the M40Z300AV, the THS pin must be tied to ground (as shown in Table 6., page 11).

If chip enable access is in progress during a power fail detection, that memory cycle continues to completion before the memory is write protected. If the memory cycle is not terminated within time t_{WPT} , $\overline{E1CON}$ to $\overline{E4CON}$ are unconditionally driven high, write protecting the SRAM. A power failure during

a WRITE cycle may corrupt data at the currently addressed location, but does not jeopardize the rest of the SRAM's contents. At voltages below V_{PFD} (min), the user can be assured the memory will be write protected within the Write Protect Time (t_{WPT}) provided the V_{CC} fall time exceeds t_f (see Figure 7., page 6).

As V_{CC} continues to degrade, the internal switch disconnects V_{CC} and connects the internal battery to V_{OUT} . This occurs at the switchover voltage (V_{SO}). Below the V_{SO} , the battery provides a voltage V_{OHB} to the SRAM and can supply current I_{OUT2} (see Table 6., page 11).

When V_{CC} rises above V_{SO} , V_{OUT} is switched back to the supply voltage. Outputs $\overline{E1CON}$ to $\overline{E4CON}$ are held inactive for t_{CEP} (120ms maximum) after the power supply has reached V_{PFD} , independent of the \overline{E} input, to allow for processor stabilization (see Figure 11., page 12).

Two to Four Decodes

The M40Z300AV includes a 2 input (A, B) decoder which allows the control of up to 4 independent SRAMs. The Truth Table for these inputs is shown in Table 2.

Table 2. Truth Table

Inputs			Outputs			
\overline{E}	B	A	$\overline{E1CON}$	$\overline{E2CON}$	$\overline{E3CON}$	$\overline{E4CON}$
H	X	X	H	H	H	H
L	X	L	L	H	H	H
L	L	H	H	L	H	H
L	H	L	H	H	L	H
L	H	H	H	H	H	L

Figure 7. Address-Decode Time

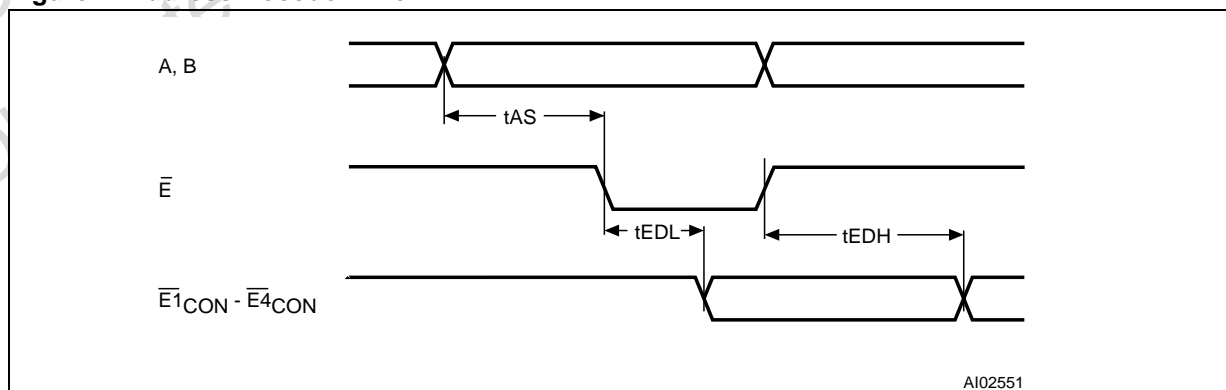

Note: During system design, compliance with the SRAM timing parameters must comprehend the propagation delay between $\overline{E1CON}$ - $\overline{E4CON}$.



Data Retention Lifetime Calculation

Most low power SRAMs on the market today can be used with the M40Z300AV NVRAM SUPERVISOR. There are, however some criteria which should be used in making the final choice of which SRAM to use. The SRAM must be designed in a way where the chip enable input disables all other inputs to the SRAM. This allows inputs to the M40Z300AV and SRAMs to be "Don't care" once V_{CC} falls below $V_{PFD}(\min)$. The SRAM should also guarantee data retention down to $V_{CC} = 2.0V$. The chip enable access time must be sufficient to meet the system needs with the chip enable propagation delays included. If the SRAM includes a second chip enable pin (E2), this pin should be tied to V_{OUT} .

If data retention lifetime is a critical parameter for the system, it is important to review the data retention current specifications for the particular SRAMs being evaluated. Most SRAMs specify a data retention current at 3.0V. Manufacturers generally specify a typical condition for room temperature along with a worst case condition (generally at elevated temperatures). The system level requirements will determine the choice of which value to use.

The data retention current value of the SRAMs can then be added to the I_{BAT} value of the M40Z300AV to determine the total current requirements for data retention. The available battery capacity for the SNAPHAT[®] of your choice can then be divided by this current to determine the amount of data retention available (see Table 13, page 18).

CAUTION: Take care to avoid inadvertent discharge through V_{OUT} and $E1CON - E4CON$ after battery has been attached.

For a further more detailed review of lifetime calculations, please see Application Note AN1012.

Power-on Reset Output

All microprocessors have a reset input which forces them to a known state when starting. The M40Z300AV has a reset output (RST) pin which is guaranteed to be low within t_{WPT} of V_{PFD} (see Table 7., page 13). This signal is an open drain configuration. An appropriate pull-up resistor should

be chosen to control the rise time. This signal will be valid for all voltage conditions, even when V_{CC} equals V_{SS} .

Once V_{CC} exceeds the power failure detect voltage V_{PFD} , an internal timer keeps RST low for t_{REC} to allow the power supply to stabilize.

Battery Low Pin

The M40Z300AV automatically performs battery voltage monitoring upon power-up, and at factory-programmed time intervals of at least 24 hours. The Battery Low (BL) pin will be asserted if the battery voltage is found to be less than approximately 2.5V. The BL pin will remain asserted until completion of battery replacement and subsequent battery low monitoring tests, either during the next power-up sequence or the next scheduled 24-hour interval.

If a battery low is generated during a power-up sequence, this indicates that the battery is below 2.5V and may not be able to maintain data integrity in the SRAM. Data should be considered suspect, and verified as correct. A fresh battery should be installed.

If a battery low indication is generated during the 24-hour interval check, this indicates that the battery is near end of life. However, data is not compromised due to the fact that a nominal V_{CC} is supplied. In order to insure data integrity during subsequent periods of battery back-up mode, the battery should be replaced. The SNAPHAT[®] top should be replaced with valid V_{CC} applied to the device.

The M40Z300AV only monitors the battery when a nominal V_{CC} is applied to the device. Thus applications which require extensive durations in the battery back-up mode should be powered-up periodically (at least once every few months) in order for this technique to be beneficial. Additionally, if a battery low is indicated, data integrity should be verified upon power-up via a checksum or other technique. The BL pin is an open drain output and an appropriate pull-up resistor to V_{CC} should be chosen to control the rise time.

V_{CC} Noise And Negative Going Transients

I_{CC} transients, including those produced by output switching, can produce voltage fluctuations, resulting in spikes on the V_{CC} bus. These transients can be reduced if capacitors are used to store energy which stabilizes the V_{CC} bus. The energy stored in the bypass capacitors will be released as low going spikes are generated or energy will be absorbed when overshoots occur. A ceramic bypass capacitor value of 0.1μF (as shown in Figure 8) is recommended in order to provide the needed filtering.

In addition to transients that are caused by normal SRAM operation, power cycling can generate negative voltage spikes on V_{CC} that drive it to values below V_{SS} by as much as one volt. These negative spikes can cause data corruption in the SRAM while in battery backup mode. To protect from these voltage spikes, STMicroelectronics recommends connecting a schottky diode from V_{CC} to V_{SS} (cathode connected to V_{CC}, anode to V_{SS}). Schottky diode 1N5817 is recommended for through hole and MBRS120T3 is recommended for surface mount.

Figure 8. Supply Voltage Protection

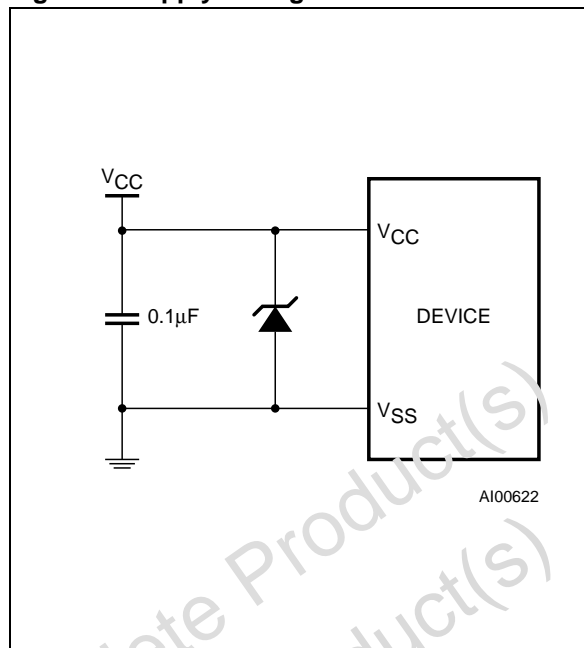

Obsolete Product(s) - Obsolete Product(s)
Obsolete Product(s) - Obsolete Product(s)

MAXIMUM RATING

Stressing the device above the rating listed in the "Absolute Maximum Ratings" table may cause permanent damage to the device. These are stress ratings only and operation of the device at these or any other conditions above those indicated in the Operating sections of this specification is

not implied. Exposure to Absolute Maximum Rating conditions for extended periods may affect device reliability. Refer also to the STMicroelectronics SURE Program and other relevant quality documents.

Table 3. Absolute Maximum Ratings

Symbol	Parameter	Value	Unit	
T _A	Ambient Operating Temperature	Grade 1	0 to 70	°C
		Grade 6	-40 to 85	°C
T _{STG}	Storage Temperature	SNAPHAT®	-40 to 85	°C
		SOIC	-55 to 125	°C
T _{SLD} ^(1,2,3)	Lead Solder Temperature for 10 seconds	260	°C	
V _{IO}	Input or Output Voltage	-0.3 to V _{CC} + 0.3	V	
V _{CC}	Supply Voltage	-0.3 to 4.6	V	
I _O	Output Current	20	mA	
P _D	Power Dissipation	1	W	

- Note: 1. Reflow at peak temperature of 215°C to 225°C for < 60 seconds (total thermal budget not to exceed 180°C for between 90 to 120 seconds).
 2. For SO package, standard lead finish: Reflow at peak temperature of 225°C (total thermal budget not to exceed 180°C for between 90 to 150 seconds).
 3. For SO package, Lead-free (Pb-free) lead finish: Reflow at peak temperature of 260°C (total thermal budget not to exceed 245°C for greater than 30 seconds).

CAUTION: Negative undershoots below -0.3V are not allowed on any pin while in the Battery Back-up mode.

CAUTION: Do NOT wave solder SOIC to avoid damaging SNAPHAT sockets.

DC AND AC PARAMETERS

This section summarizes the operating and measurement conditions, as well as the DC and AC characteristics of the device. The parameters in the following DC and AC Characteristic tables are derived from tests performed under the Measure-

ment Conditions listed in the relevant tables. Designers should check that the operating conditions in their projects match the measurement conditions when using the quoted parameters.

Table 4. DC and AC Measurement Conditions

Parameter		M40Z300AV
V _{CC} Supply Voltage		3.0 to 3.6V
Ambient Operating Temperature	Grade 1	0 to 70°C
	Grade 6	-40 to 85°C
Load Capacitance (C _L)		50pF
Input Rise and Fall Times		≤ 5ns
Input Pulse Voltages		0 to 3V
Input and Output Timing Ref. Voltages		1.5V

Note: Output High Z is defined as the point where data is no longer driven.

Figure 9. AC Testing Load Circuit

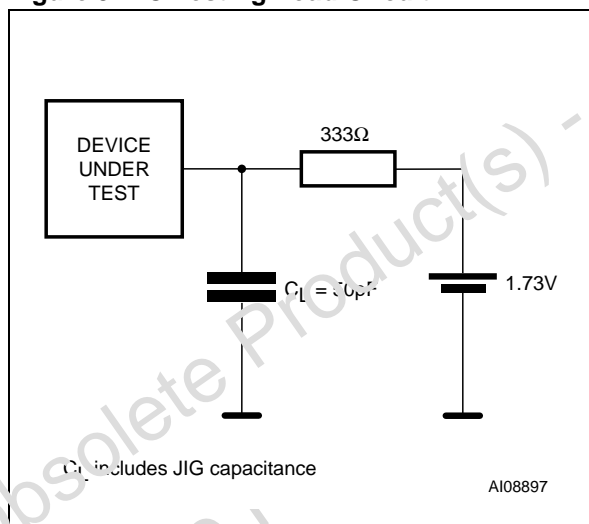

Table 5. Capacitance

Symbol	Parameter ^(1,2)	Min	Max	Unit
C _{IN}	Input Capacitance		8	pF
C _{OUT} ⁽³⁾	Input/Output Capacitance		10	pF

Note: 1. Sampled only, not 100% tested.
 2. At 25°C, f = 1MHz.
 3. Outputs deselected.

Table 6. DC Characteristics

Sym	Parameter	Test Condition ⁽¹⁾	Min	Typ	Max	Unit
I_{LI} ⁽²⁾	Input Leakage Current	$0V \leq V_{IN} \leq V_{CC}$			± 1	μA
I_{CC}	Supply Current	Outputs open		2	4	mA
V_{IL}	Input Low Voltage		-0.3		0.8	V
V_{IH}	Input High Voltage		2.0		$V_{CC} + 0.3$	V
V_{OL}	Output Low Voltage	$I_{OL} = 4.0mA$			0.4	V
	Output Low Voltage (open drain) ⁽³⁾	$I_{OL} = 10mA$			0.4	V
V_{OH}	Output High Voltage	$I_{OH} = -2.0mA$	2.4			V
V_{OHB}	V_{OH} Battery Back-up ⁽⁴⁾	$I_{OUT2} = -1.0\mu A$	2.0	2.9	3.6	V
I_{OUT1}	V_{OUT} Current (Active)	$V_{OUT} > V_{CC} - 0.3$			150	mA
		$V_{OUT} > V_{CC} - 0.2$			100	mA
I_{OUT2}	V_{OUT} Current (Battery Back-up)	$V_{OUT} > V_{BAT} - 0.3$		100		μA
I_{CCDR}	Data Retention Mode Current ⁽⁵⁾				100	nA
V_{PFD}	Power-fail Deselect Voltage (THS = V_{SS}) ⁽⁶⁾		2.8	2.9	3.0	V
V_{SO}	Battery Back-up Switchover Voltage		2.7	2.8	2.9	V
V_{BAT}	Battery Voltage		2.0	2.9	3.6	V

Note: 1. Valid for Ambient Operating Temperature: $T_A = 0$ to $70^\circ C$ or -40 to $85^\circ C$; $V_{CC} = 3.0$ to $3.6V$ (except where noted).

2. Outputs deselected.

3. For RST & BL pins (Open Drain).

4. Chip Enable outputs ($\overline{E1CON}$ - $\overline{E4CON}$) can only sustain CMOS leakage currents in the battery back-up mode. Higher leakage currents will reduce battery life.

5. Measured with V_{OUT} and $\overline{E1CON}$ - $\overline{E4CON}$ open.

6. THS pin must be tied to V_{SS} .

Figure 10. Power Down Timing

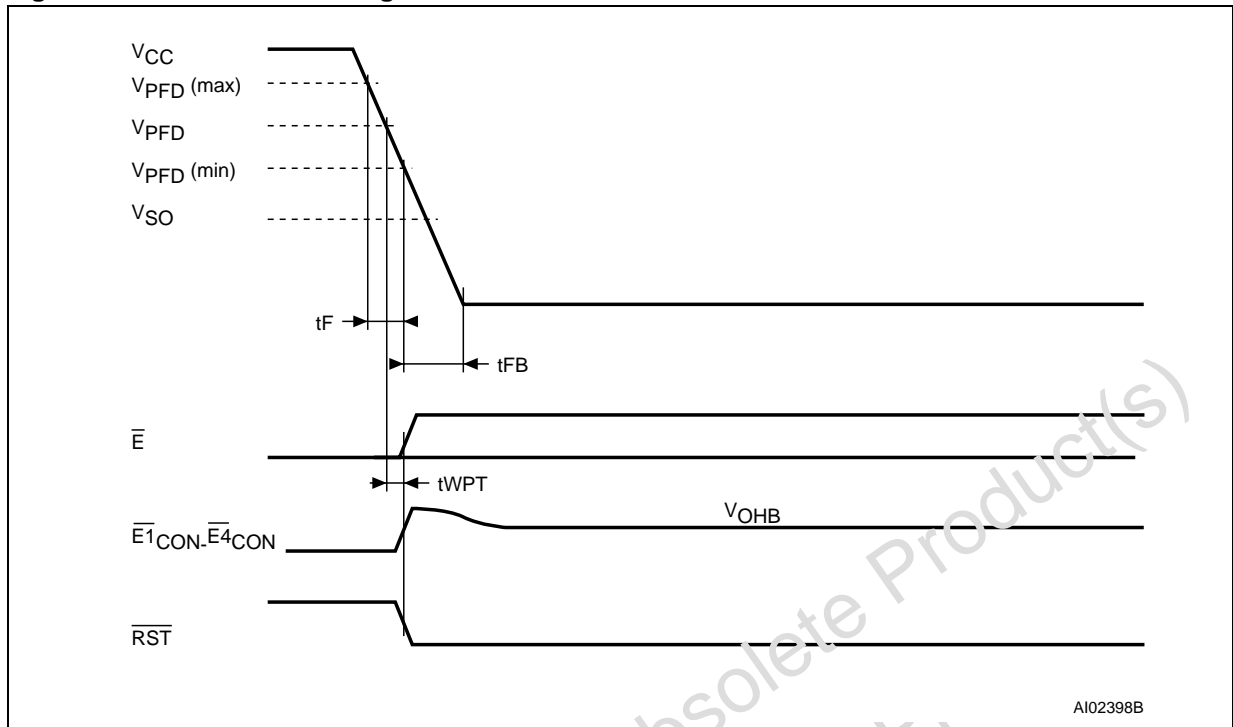

Figure 11. Power Up Timing

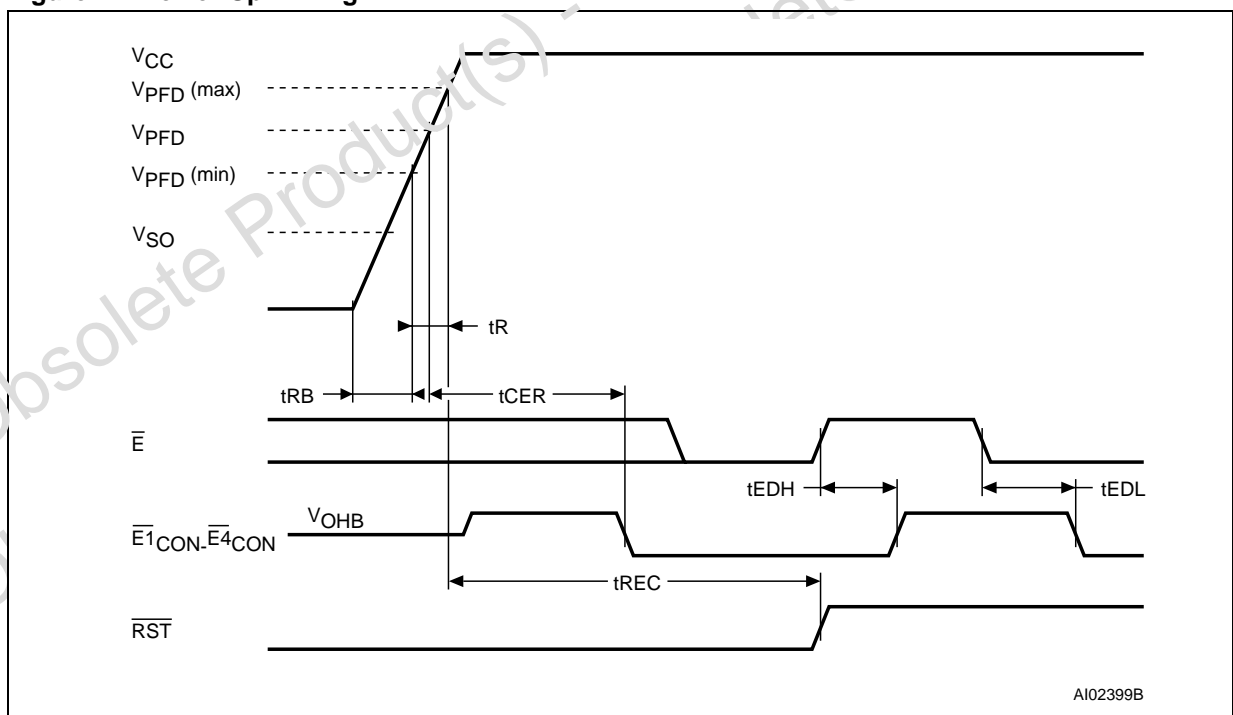

Table 7. Power Down/Up Mode AC Characteristics

Symbol	Parameter ⁽¹⁾	Min	Max	Unit
$t_F^{(2)}$	$V_{PFD}(\max)$ to $V_{PFD}(\min)$ V_{CC} Fall Time	300		μs
$t_{FB}^{(3)}$	$V_{PFD}(\min)$ to V_{SS} V_{CC} Fall Time	150		μs
t_R	$V_{PFD}(\min)$ to $V_{PFD}(\max)$ V_{CC} Rise Time	10		μs
t_{EDL}	Chip Enable Propagation Delay Low		20	ns
t_{EDH}	Chip Enable Propagation Delay High		20	ns
t_{AS}	A, B set up to \bar{E}	0		ns
t_{CER}	Chip Enable Recovery	40	120	ms
$t_{REC}^{(4)}$	$V_{PFD}(\max)$ to \overline{RST} High	40	120	ms
t_{WPT}	Write Protect Time	40	250	μs
t_{RB}	V_{SS} to $V_{PFD}(\min)$ V_{CC} Rise Time	1		μs

- Note: 1. Valid for Ambient Operating Temperature: $T_A = 0$ to $70^\circ C$ or -40 to $85^\circ C$; $V_{CC} = 3.0$ to $3.6V$ (except where noted).
 2. $V_{PFD}(\max)$ to $V_{PFD}(\min)$ fall time of less than t_F may result in deselection/write protection not occurring until $200 \mu s$ after V_{CC} passes $V_{PFD}(\min)$.
 3. $V_{PFD}(\min)$ to V_{SS} fall time of less than t_{FB} may cause corruption of RAM data.
 4. $t_{REC}(\min) = 20ms$ for industrial temperature Grade 6 device.

PACKAGE MECHANICAL INFORMATION

Figure 12. SOH28 – 28-lead Plastic Small Outline, 4-socket battery SNAPHAT, Package Outline

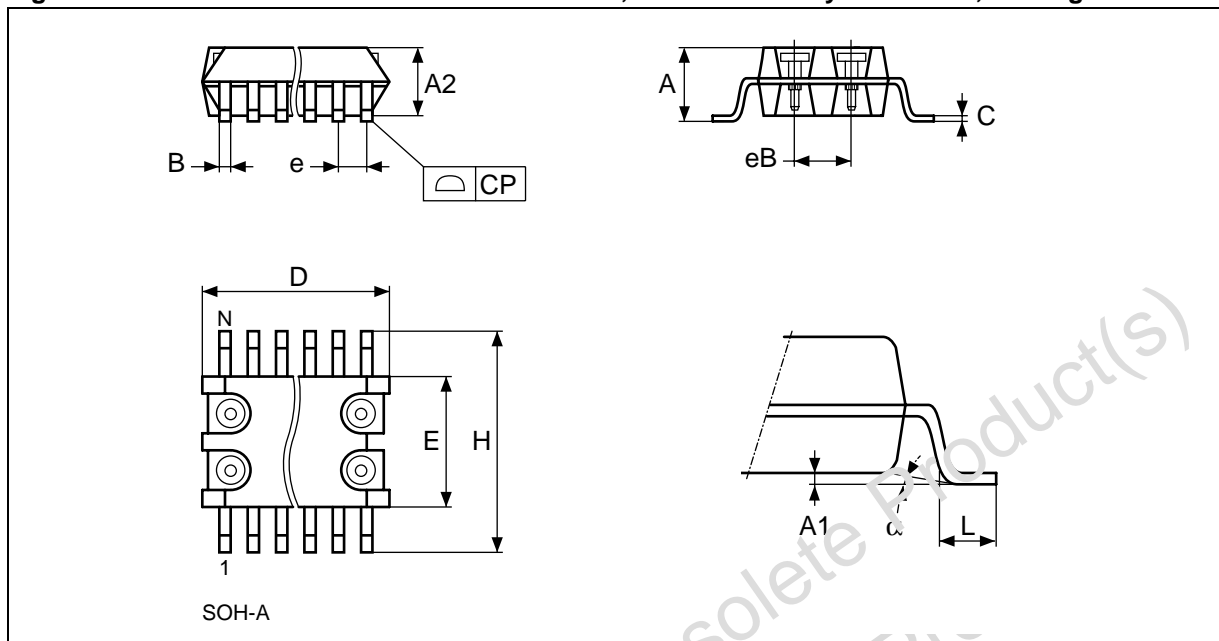

Note: Drawing is not to scale.

Table 8. SOH28 – 28-lead Plastic Small Outline, battery SNAPHAT, Package Mechanical Data

Symbol	mm			inches		
	Typ	Min	Max	Typ	Min	Max
A			3.05			0.120
A1		0.05	0.36		0.002	0.014
A2		2.34	2.69		0.092	0.106
B		0.36	0.51		0.014	0.020
C		0.15	0.32		0.006	0.012
D		17.71	18.49		0.697	0.728
E		8.23	8.89		0.324	0.350
e	1.27	–	–	0.050	–	–
eB		3.20	3.61		0.126	0.142
H		11.51	12.70		0.453	0.500
L		0.41	1.27		0.016	0.050
alpha		0°	8°		0°	8°
N	28			28		
CP			0.10			0.004

Figure 13. SH – 4-pin SNAPHAT Housing for 48mAh Battery, Package Outline

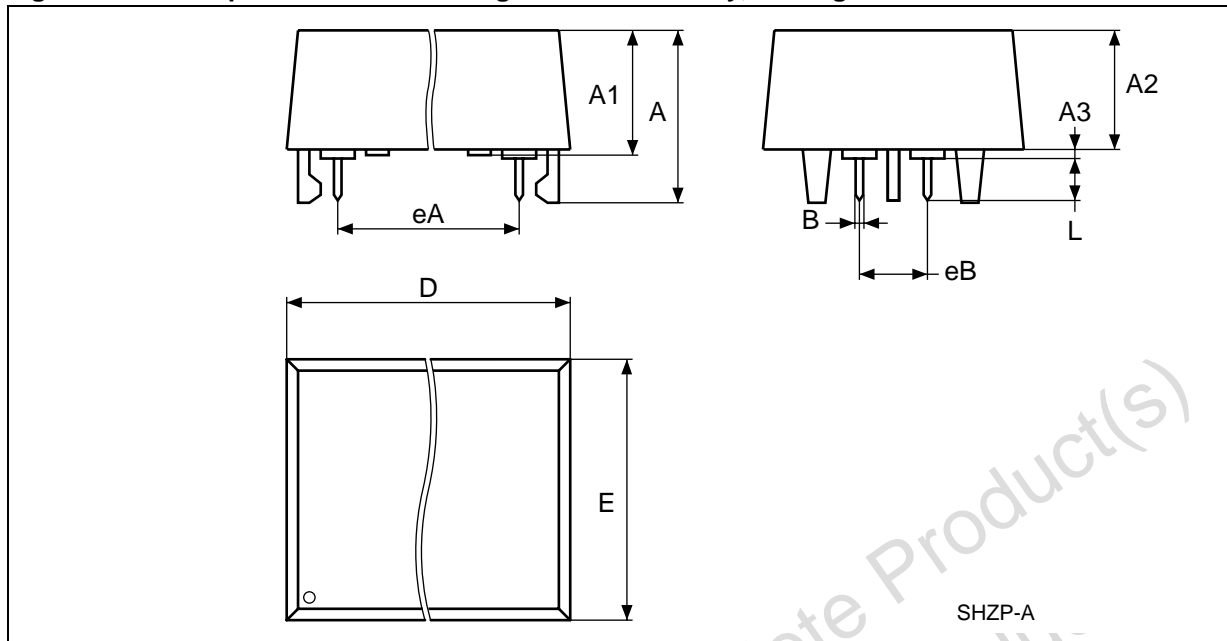

Note: Drawing is not to scale.

Table 9. SH – 4-pin SNAPHAT Housing for 48mAh Battery, Package Mechanical Data

Symbol	mm			inches		
	Typ	Min	Max	Typ	Min	Max
A			9.78			0.385
A1		6.73	7.24		0.265	0.285
A2		6.48	6.99		0.255	0.275
A3			0.38			0.015
B		0.46	0.56		0.018	0.022
D		21.21	21.84		0.835	0.860
E		14.22	14.99		0.560	0.590
eA		15.55	15.95		0.612	0.628
eB		3.20	3.61		0.126	0.142
L		2.03	2.29		0.080	0.090

Figure 14. SH – 4-pin SNAPHAT Housing for 120mAh Battery, Package Outline

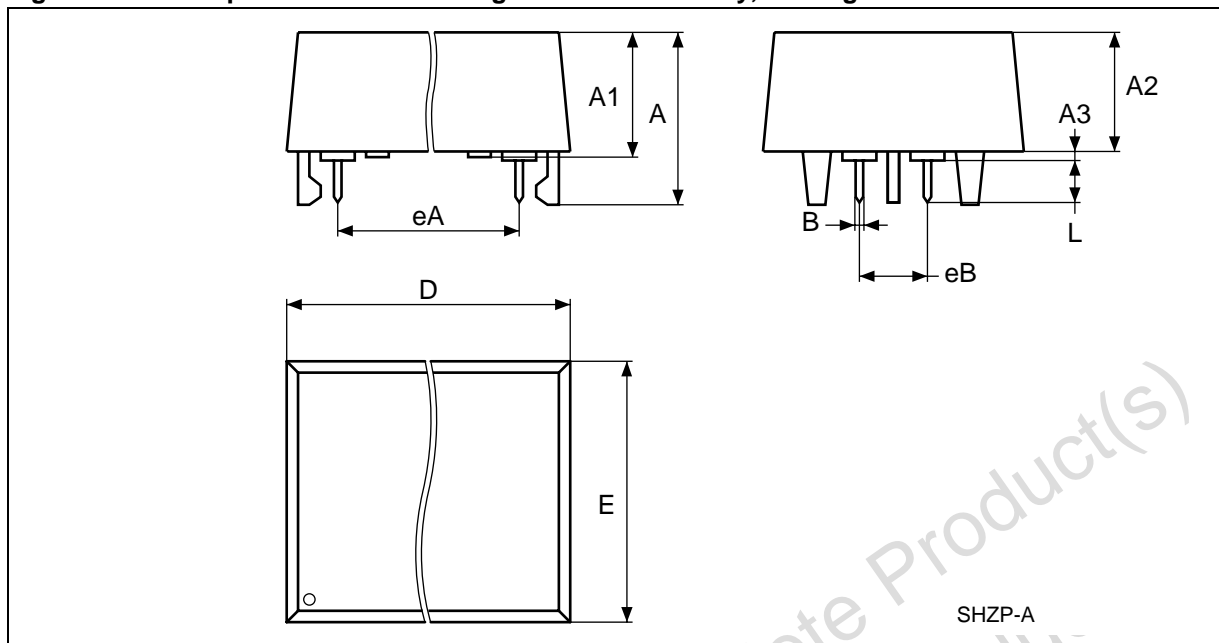

Note: Drawing is not to scale.

Table 10. SH – 4-pin SNAPHAT Housing for 120mAh Battery, Package Mechanical Data

Symbol	mm			inches		
	Typ	Min	Max	Typ	Min	Max
A			10.54			0.415
A1		8.00	8.51		0.315	.0335
A2		7.24	8.00		0.285	0.315
A3			0.38			0.015
B		0.46	0.56		0.018	0.022
D		21.21	21.84		0.835	0.860
E		17.27	18.03		0.680	0.710
eA		15.55	15.95		0.612	0.628
eB		3.20	3.61		0.126	0.142
L		2.03	2.29		0.080	0.090

Figure 15. SO16 – 16-lead Plastic Small Outline, 150 mils body width, Package Outline

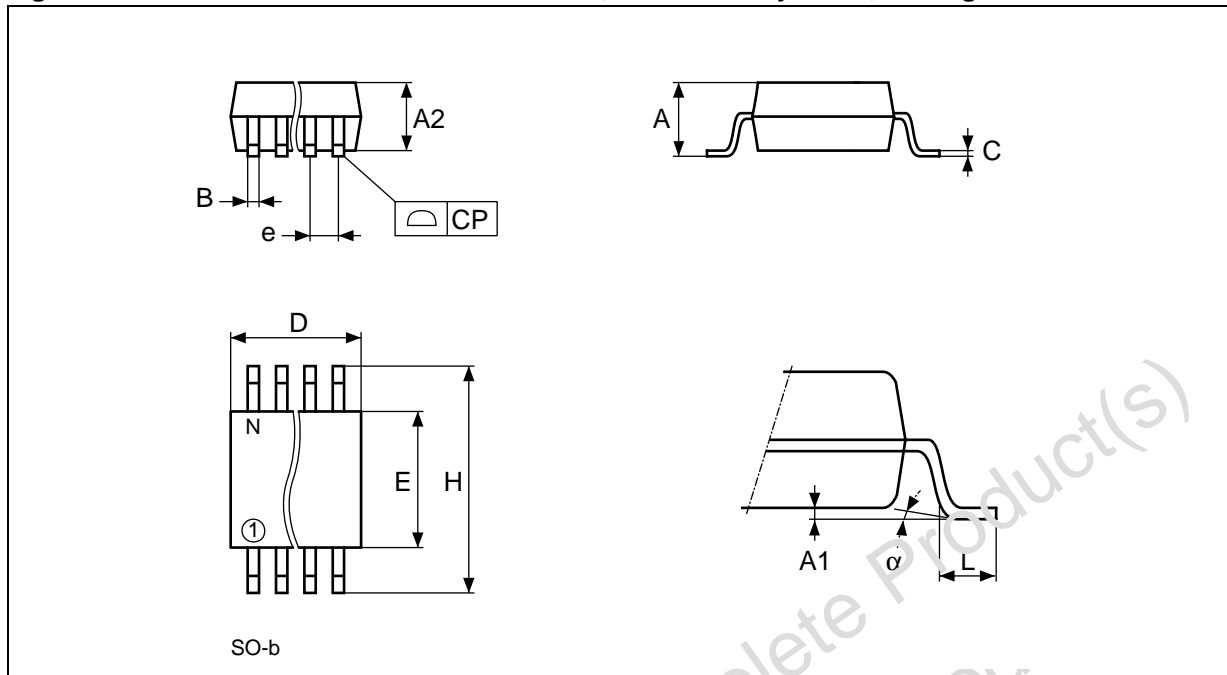

Note: Drawing is not to scale.

Table 11. SO16 – 16-lead Plastic Small Outline, 150 mils body width, Package Mechanical Data

Symbol	mm			inches		
	Typ.	Min.	Max.	Typ.	Min.	Max.
A			1.75			0.069
A1		0.10	0.25		0.004	0.010
A2			1.60			0.063
B		0.35	0.46		0.014	0.018
C		0.19	0.25		0.007	0.010
D		9.80	10.00		0.386	0.394
E		3.80	4.00		0.150	0.158
e	1.27	–	–	0.050	–	–
H		5.80	6.20		0.228	0.244
L		0.40	1.27		0.016	0.050
α		0°	8°		0°	8°
N	16			16		
CP			0.10			0.004

PART NUMBERING

Table 12. Ordering Information Example

Example:	M40Z	300AV	MQ	6	F
Device Type					
M40Z					
Supply and Write Protect Voltage					
300AV = V _{CC} = 3.0 to 3.6V THS = V _{SS} ; 2.8V ≤ V _{PFD} ≤ 3.0V					
Package					
MQ = SO16 MH ^(1,2) = SOH28					
Temperature Range					
1 = 0 to 70°C 6 = -40 to 85°C					
Shipping Method for SOIC					
E = Lead-free Package (ECO [®] PACK [™]), Tubes F = Lead-free Package (ECC [®] PACK [™]), Tape & Reel					

Note: 1. The SOIC package (SOH28) requires the battery package (SNAPHAT[®]) which is ordered separately under the part number "M4Zxx-BR00SH" in plastic tube or "M4Zxx-BR00SHTR" in Tape & Reel form.

Caution: Do not place the SNAPHAT battery package "M4Zxx-BR00SH" in conductive foam as it will drain the lithium button-cell battery.

2. Contact Local Sales Office for availability of SNAPHAT (MH) package.

For a list of available options (e.g., Speed, Package) or for further information on any aspect of this device, please contact the ST Sales Office nearest to you.

Table 13. SNAPHAT[®] Battery Table

Part Number	Description	Package
M4Z28-BR00SH	Lithium Battery (48mAh) SNAPHAT	SH
M4Z32-BR00SH	Lithium Battery (120mAh) SNAPHAT	SH

REVISION HISTORY**Table 14. Document Revision History**

Date	Version	Revision Details
November 14, 2003	1.0	First Issue
19-Nov-03	1.1	Correct shipping information (Table 12)
09-Mar-04	2.0	Reformatted; updated Lead-free information (Table 3, 12)

Obsolete Product(s) - Obsolete Product(s)
Obsolete Product(s) - Obsolete Product(s)

Information furnished is believed to be accurate and reliable. However, STMicroelectronics assumes no responsibility for the consequences of use of such information nor for any infringement of patents or other rights of third parties which may result from its use. No license is granted by implication or otherwise under any patent or other rights of STMicroelectronics. Specifications mentioned in this publication are subject to change without notice. This publication supersedes and replaces all information previously supplied. STMicroelectronics products are not authorized for use as critical components in life support devices or systems without express written approval of STMicroelectronics.

The ST logo is a registered trademark of STMicroelectronics.

All other names are the property of their respective owners.

© 2004 STMicroelectronics - All rights reserved

STMicroelectronics GROUP OF COMPANIES

Australia - Belgium - Brazil - Canada - China - Czech Republic - Finland - France - Germany -
Hong Kong - India - Israel - Italy - Japan - Malaysia - Malta - Morocco - Singapore -
Spain - Sweden - Switzerland - United Kingdom - United States

www.st.com