

45V 4A QUAD POWER HALF BRIDGE

PRODUCT PREVIEW

1 FEATURES

- MULTIPOWER BCD TECHNOLOGY
- MINIMUM INPUT OUTPUT PULSE WIDTH DISTORTION
- 200mΩ R_{dsON} COMPLEMENTARY DMOS OUTPUT STAGE
- CMOS COMPATIBLE LOGIC INPUTS
- THERMAL PROTECTION
- THERMAL WARNING OUTPUT
- UNDER VOLTAGE PROTECTION
- SHORT CIRCUIT PROTECTION

2 DESCRIPTION

STA506A is a monolithic quad half bridge stage in Multipower BCD Technology.

The device can be used as dual bridge or reconfigured, by connecting CONFIG pin to V_{dd} pin, as single bridge with double current capability, and as half

Figure 1. Package



Table 1. Order Codes

Part Number	Package
STA506A	Power SO36 (Slugg Chip)

bridge (Binary mode) with half current capability.

The device is particularly designed to make the output stage of a stereo All-Digital High Efficiency (DDX™) amplifier capable to deliver 60 + 60W @ THD = 10% at V_{CC} 32V output power on 8Ω load and 80W @ THD = 10% at V_{CC} 36V on 8Ω load in single BTL configuration. In single BTL configuration is also capable to deliver a peak of 120W @ THD = 10% at V_{CC} = 32V on 4Ω load. The input pins have threshold proportional to V_L pin voltage.

Figure 2. Application Circuit (Dual BTL)

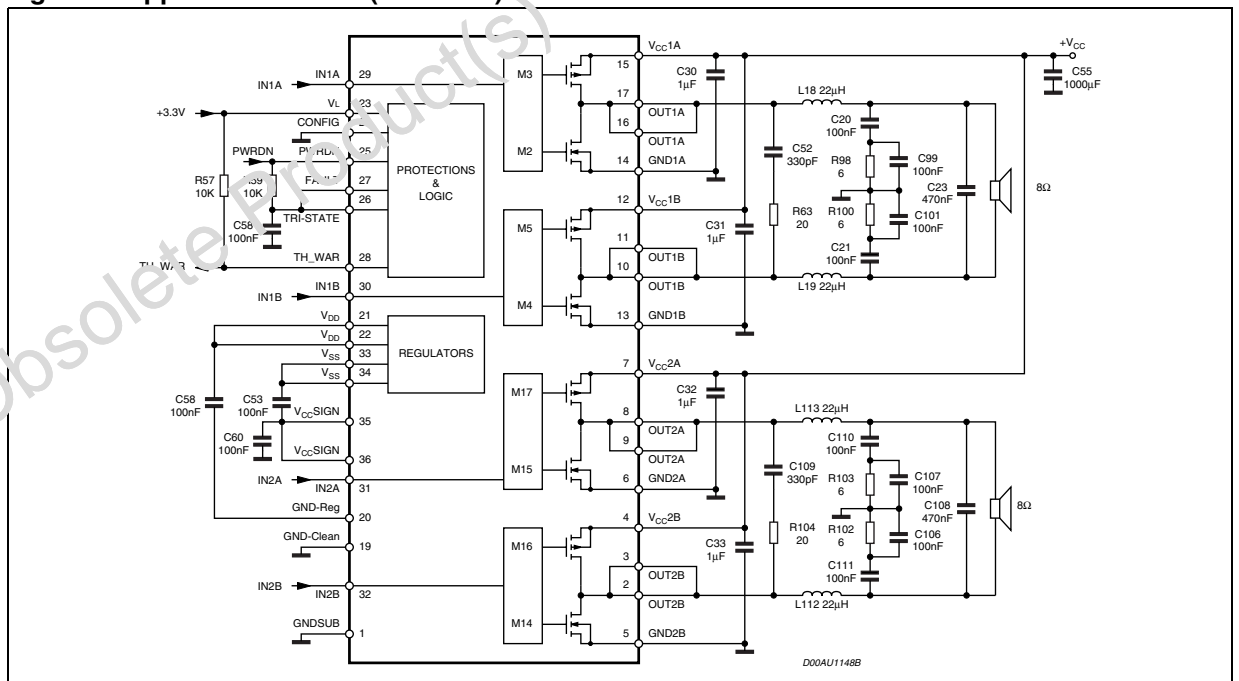

Table 2. Pin Function

Pin n.	Pin Name	Description
1	GND-SUB	Substrate Ground
2 ; 3	OUT2B	Output Half Bridge 2B
4	V _{CC} 2B	Positive Supply
5	GND2B	Negative Supply
6	GND2A	Negative Supply
7	V _{CC} 2A	Positive Supply
8 ; 9	OUT2A	Output Half Bridge 2A
10 ; 11	OUT1B	Output Half Bridge 1B
12	V _{CC} 1B	Positive Supply
13	GND1B	Negative Supply
14	GND1A	Negative Supply
15	V _{CC} 1A	Positive Supply
16 ; 17	OUT1A	Output Half Bridge 1A
18	NC	Not Connected
19	GND-clean	Logical Ground
20	GND-reg	Ground for regulator V _{dd}
21 ; 22	V _{dd}	5V Regulator Referred to Ground
23	VL	Logic Reference Voltage
24	CONFIG	Configuration pin
25	PWRDN	Stand-by pin
26	TRI-STATE	High-Z pin
27	FAULT	Fault pin Advisor
28	TH-WAR	Thermal Warning Advisor
29	IN1A	Input of Half Bridge 1A
30	IN1B	Input of Half Bridge 1B
31	IN2A	Input of Half Bridge 2A
32	IN2B	Input of Half Bridge 2B
33 ; 34	V _{SS}	5V Regulator Referred to +V _{CC}
35 ; 36	V _{CC} Sign	Signal Positive Supply

Table 3. Functional Pin Status

Pin name	Pin n.	Logical value	IC -STATUS
FAULT	27	0	Fault detected (Short circuit, or Thermal ..)
FAULT (*)	27	1	Normal Operation
TRI-STATE	26	0	All powers in Hi-Z state
TRI-STATE	26	1	Normal operation
PWRDN	25	0	Low absorption
PWRDN	25	1	Normal operation
THWAR	28	0	Temperature of the IC =130°C
THWAR(*)	28	1	Normal operation
CONFIG	24	0	Normal Operation
CONFIG(**)	24	1	OUT1A = OUT1B ; OUT2A=OUT2B (IF IN1A = IN1B; IN2A = IN2B)

(*) : The pin is open collector. To have the high logic value, it needs to be pulled up by a resistor.

(**) : To put CONFIG = 1 means connect Pin 24 (CONFIG) to Pins 21, 22 (Vdd) to implement single BTL (mono mode) operation for high current.

Figure 3. Pin Connection

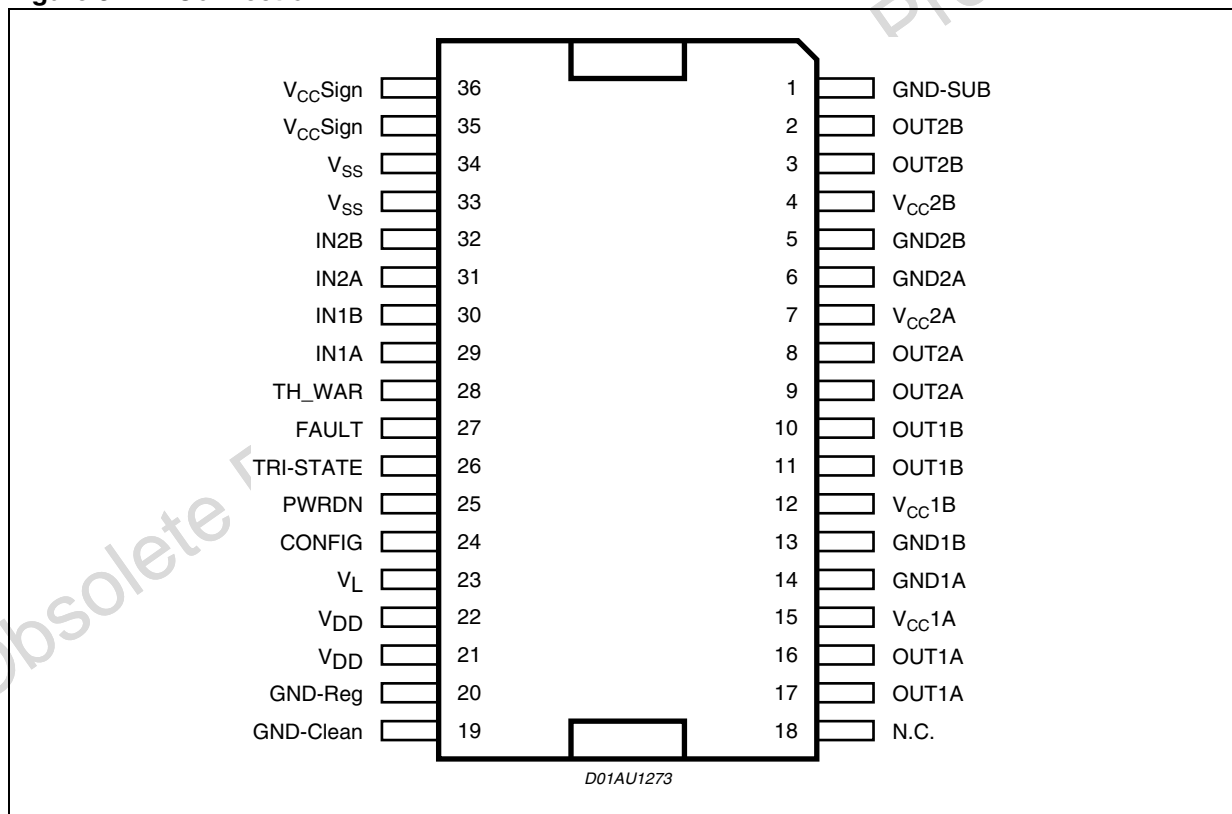

Table 4. Absolute Maximum Ratings

Symbol	Parameter	Value	Unit
V _{CC}	DC Supply Voltage (Pin 4,7,12,15)	45	V
V _{max}	Maximum Voltage on pins 23 to 32 (logic reference)	5.5	V
P _{tot}	Power Dissipation (T _{case} = 70°C)	50	W
T _{op}	Operating Temperature Range	0 to 70	°C
T _{stg} , T _j	Storage and Junction Temperature	-40 to 150	°C

Table 5. (*) Recommended Operating Conditions

Symbol	Parameter	Min.	Typ.	Max.	Unit
V _{CC}	DC Supply Voltage	10		40	V
V _L	Input Logic Reference	2.7	3.3	5.0	v
T _{amb}	Ambient Temperature	0		70	°C

(*) Performances not guaranteed beyond recommended Operating Conditions

Table 6. Thermal Data

Symbol	Parameter	Min.	Typ.	Max.	Unit
T _{j-case}	Thermal Resistance Junction to Case (thermal pad)			1.5	°C/W
T _{jSD}	Thermal shut-down junction temperature		150		°C
T _{warn}	Thermal warning temperature		130		°C
t _{hSD}	Thermal shut-down hysteresis		25		°C

Table 7. Electrical Characteristics: refer to circuit in Fig.1 (V_L = 3.3V; V_{CC} = 32V; R_L = 8Ω; f_{sw} = 384KHz; T_{amb} = 25°C unless otherwise specified)

Symbol	Parameter	Test conditions	Min.	Typ.	Max.	Unit
R _{dsON}	Power Pchannel/Nchannel MOSFET RdsON	I _d =1A		200	270	mΩ
I _{dss}	Power Pchannel/Nchannel leakage I _{dss}	V _{CC} =35V			50	μA
g _N	Power Pchannel RdsON Matching	I _d =1A	95			%
g _P	Power Nchannel RdsON Matching	I _d =1A	95			%
Dt _s	Low current Dead Time (static)	see test circuit no.1; see fig. 3		10	20	ns
Dt _d	High current Dead Time (dinamic)	L=22μH; C = 470nF; R _L = 8 Ω I _d =3.5A; see fig. 5			50	ns
t _{d ON}	Turn-on delay time	Resistive load			100	ns
t _{d OFF}	Turn-off delay time	Resistive load			100	ns
t _r	Rise time	Resistive load; as fig.3			25	ns
t _f	Fall time	Resistive load; as fig. 3			25	ns
V _{CC}	Supply voltage operating voltage		10		40	V
V _{IN-H}	High level input voltage				V _L /2 +300mV	V

Table 7. (continued)

Symbol	Parameter	Test conditions	Min.	Typ.	Max.	Unit
V _{IN-L}	Low level input voltage		V _L /2 - 300mV			V
I _{IN-H}	Hi level Input current	Pin Voltage = V _L		1		μA
I _{IN-L}	Low level input current	Pin Voltage = 0.3V		1		μA
I _{PWRDN-H}	Hi level PWRDN pin input current	V _L = 3.3V		35		μA
V _{LOW}	Low logical state voltage V _{Low} (pin PWRDN, TRISTATE) (note 1)	V _L = 3.3V	0.8			V
V _{HIGH}	High logical state voltage V _{High} (pin PWRDN, TRISTATE) (note 1)	V _L = 3.3V			1.7	V
I _{VCC-PWRDN}	Supply CURRENT from Vcc in Power Down	PWRDN = 0			3	mA
I _{FAULT}	Output Current pins FAULT -TH-WARN when FAULT CONDITIONS	V _{pin} = 3.3V		1		mA
I _{VCC-hiz}	Supply Current from Vcc in Tri-state	V _{CC} = 30V; Tri-state = 0		22		mA
I _{VCC}	Supply Current from Vcc in operation both channel switching)	V _{CC} = 30V; Input Pulse width = 50% Duty; Switching Frequency = 384KHz; No LC filters;		50		mA
I _{VCC-q}	Isc (short circuit current limit) (note 2)		4	6	8	A
V _{UV}	Undervoltage protection threshold			7		V
t _{pw_min}	Output minimum pulse width	No Load	70		150	ns

Notes: 1. The following table explains the V_{LOW}, V_{HIGH} variation with V_L

Table 8.

V _L	V _{LOW min}	V _{HIGH max}	Unit
2.7	0.7	1.5	V
3.3	0.8	1.7	V
5	0.85	1.85	V

Note 2: see relevant Application Note AN1994

Table 9. Logic Truth Table (see fig. 4)

TRI-STATE	INxA	INxB	Q1	Q2	Q3	Q4	OUTPUT MODE
0	x	x	OFF	OFF	OFF	OFF	Hi-Z
1	0	0	OFF	OFF	ON	ON	DUMP
1	0	1	OFF	ON	ON	OFF	NEGATIVE
1	1	0	ON	OFF	OFF	ON	POSITIVE
1	1	1	ON	ON	OFF	OFF	Not used

Figure 4. Test Circuit.

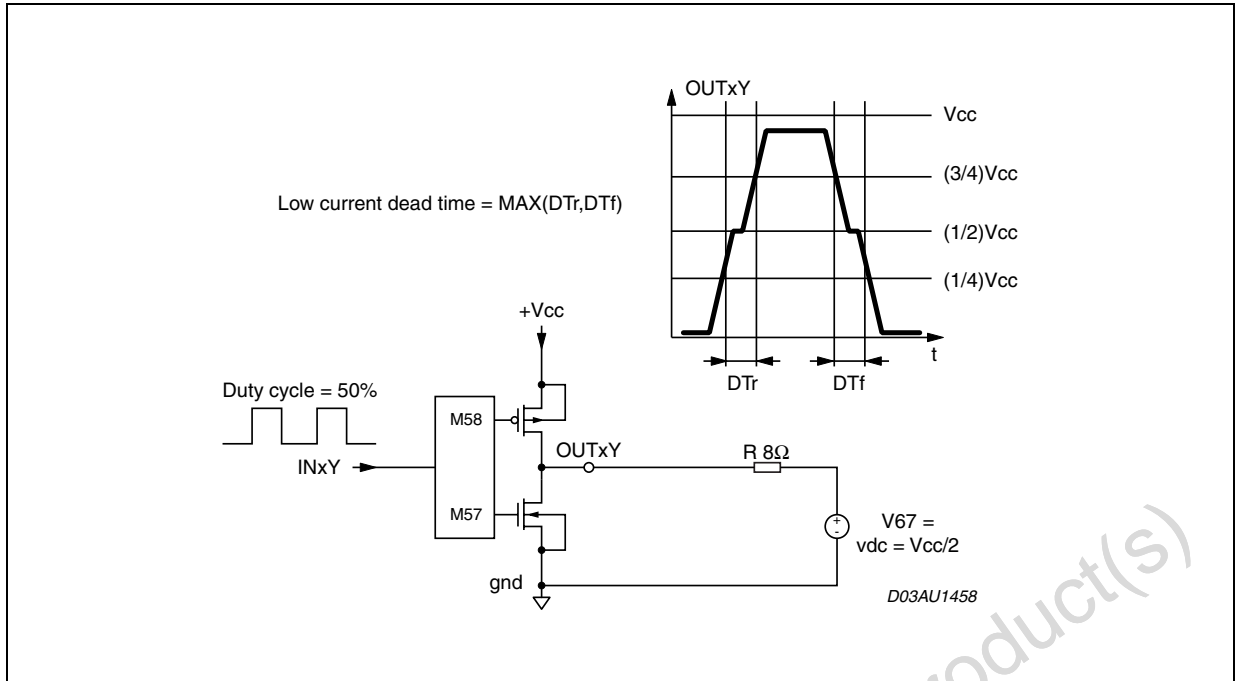

Figure 5.

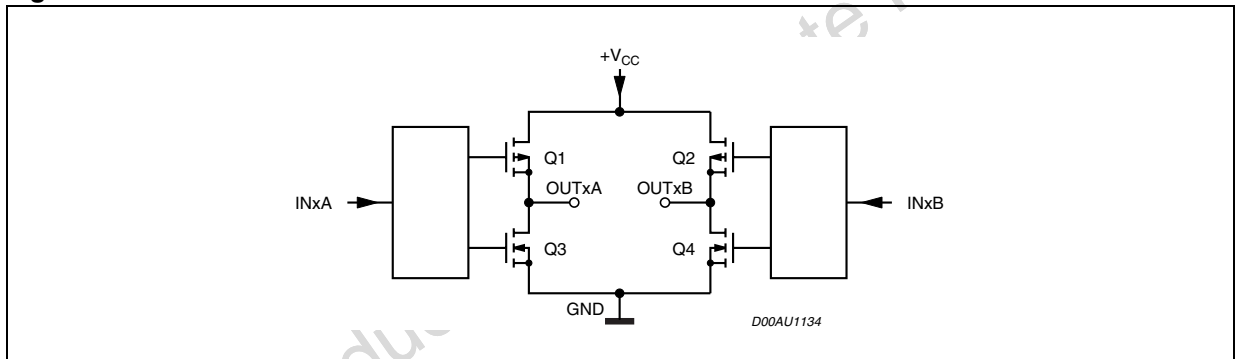
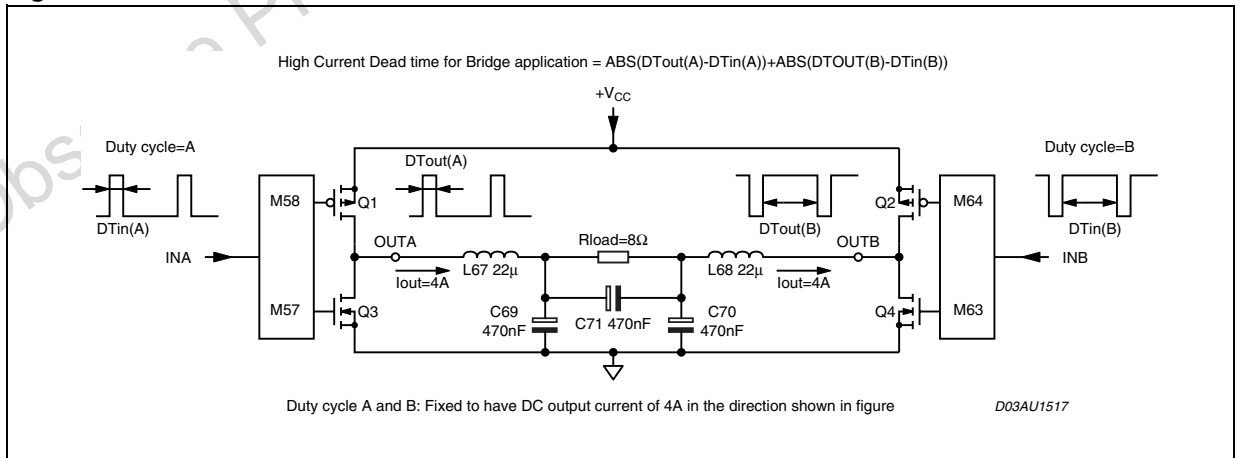

Figure 6.



3 TECHNICAL INFO:

The STA506A is a dual channel H-Bridge that is able to deliver more than 60W per channel (@ THD=10%) of audio output power in high efficiency.

The STA506A converts both DDX and binary-controlled PWM signals into audio power at the load. It includes a logic interface, integrated bridge drivers, high efficiency MOSFET outputs and thermal and short circuit protection circuitry.

In DDX mode, two logic level signals per channel are used to control high-speed MOSFET switches to connect the speaker load to the input supply or to ground in a Bridge configuration, according to the damped ternary Modulation operation.

In Binary Mode operation, both Full Bridge and Half Bridge Modes are supported. The STA506A includes over-current and thermal protection as well as an under-voltage

Lockout with automatic recovery if FAULT and TRISTATE pins are connected together to an external capacitor, as in fig.9

Figure 7. STA506A Block Diagram Full-Bridge DDX® or Binary Modes

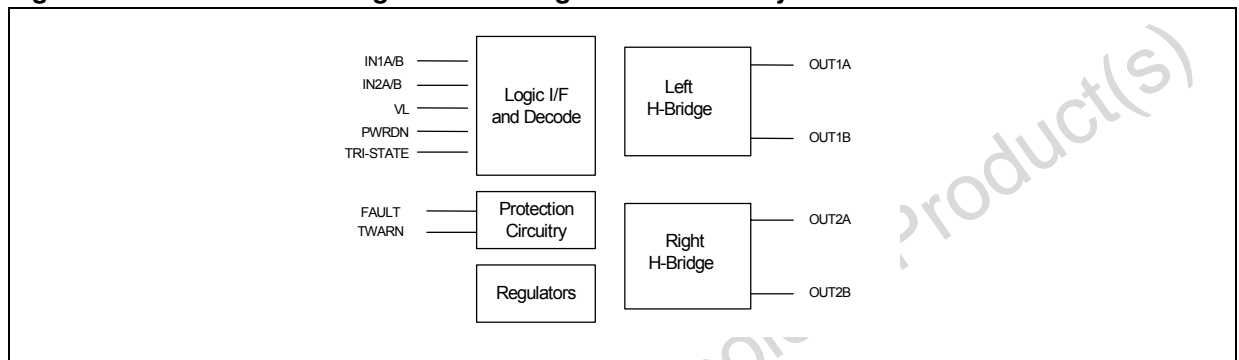
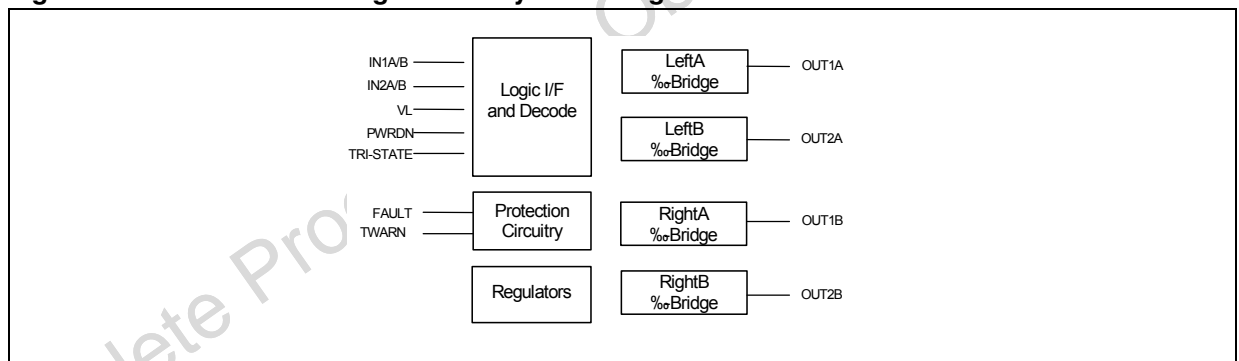

Figure 8. STA506A Block Diagram Binary Half-Bridge Mode



3.1 Logic Interface and Decode:

The STA506A power outputs are controlled using one or two logic level timing signals. In order to provide a proper logic interface, the V_L input must operate at the same voltage as the DDX control logic supply.

3.2 Protection Circuitry:

The STA506A includes protection circuitry for over-current and thermal overload conditions. A thermal warning pin (pin.28) is activated low (open drain MOSFET) when the IC temperature exceeds 130°C, in advance of the thermal shutdown protection. When a fault condition is detected, an internal fault signal acts to immediately disable the output power MOSFETs, placing both H-Bridges in high impedance state. At the same time an open-drain MOSFET connected to the fault pin (pin.27) is switched on.

There are two possible modes subsequent to activating a fault:

- **1) SHUTDOWN mode:** with FAULT (pull-up resistor) and TRI-STATE pins independent, an activated fault will disable the device, signaling low at the FAULT output.
The device may subsequently be reset to normal operation by toggling the TRI-STATE pin from High to Low to High using an external logic signal.

- **2) AUTOMATIC recovery mode:** This is shown in the Application Circuit of fig.1.
The FAULT and TRI-STATE pins are shorted together and connected to a time constant circuit comprising R59 and C58.
An activated FAULT will force a reset on the TRI-STATE pin causing normal operation to resume following a delay determined by the time constant of the circuit.
If the fault condition is still present, the circuit operation will continue repeating until the fault condition is removed.
An increase in the time constant of the circuit will produce a longer recovery interval. Care must be taken in the overall system design as not to exceed the protection thresholds under normal operation.

3.3 Power Outputs:

The STA506A power and output pins are duplicated to provide a low impedance path for the device's bridged outputs.

All duplicate power, ground and output pins must be connected for proper operation.

The PWRDN or TRI-STATE pins should be used to set all MOSFETS to the Hi-Z state during power-up until the logic power supply, V_L , is settled.

3.4 Parallel Output / High Current Operation:

When using DDX Mode output, the STA506A outputs can be connected in parallel in order to increase the output current capability to a load.

In this configuration the STA506A can provide 80W into 8 ohm or up to 120W into 4ohm.

This mode of operation is enabled with the CONFIG pin (pin.24) connected to Vdd and the inputs combined IN1A=IN1B, IN2A=IN2B and the outputs combined OUT1A=OUT1B, OUT2A=OUT2B.

3.5 Additional Informations:

Output Filter: A passive 2nd-order passive filter is used on the STA506A power outputs to reconstruct an analog Audio Signal.

System performance can be significantly affected by the output filter design and choice of passive components. A filter design for 6ohm/8ohm loads is shown in the Typical Application circuit of fig.1. Figure 9 shows a filter design suitable for 4ohm loads.

Figure 10 shows a filter for ½ bridge mode, 4 ohm loads.

3.6 Power Dissipation & Heat Sink Requirements:

The power dissipated within the device will depend primarily on the supply voltage, load impedance and output modulation level.

The PowerSO36 package of the STA506A includes an exposed thermal slug on the top of the device to provide a direct thermal path from the IC to the heatsink.

Careful consideration must be given to the overall thermal design. See figure 8 for power derating versus Slug temperature using different heatsinks and considering the $R_{th-jc} = 1.5^{\circ}\text{C/W}$.

Figure 9. STA506A Power Derating Curve

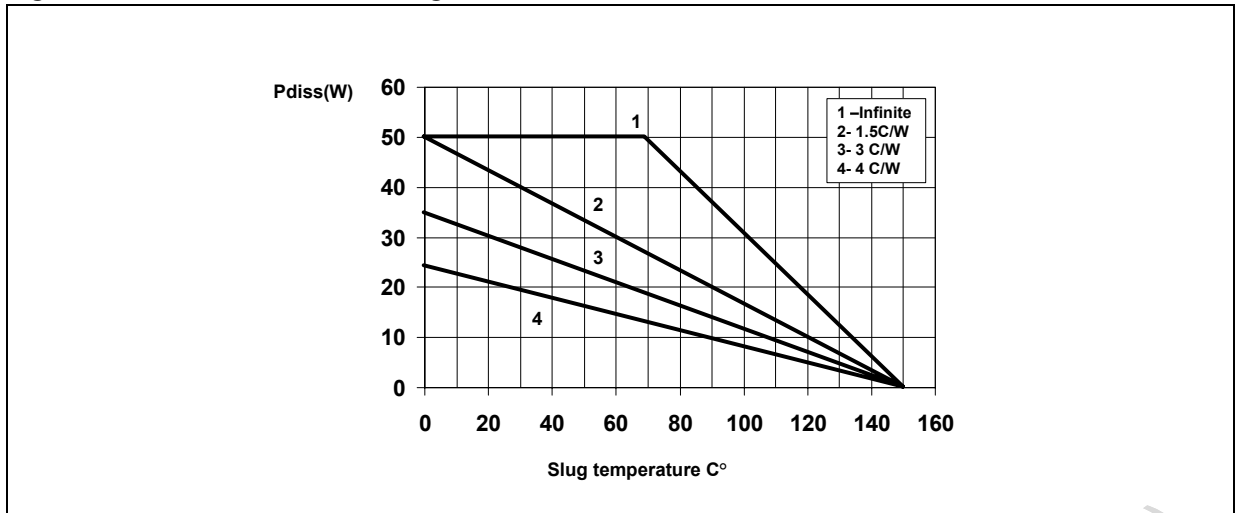
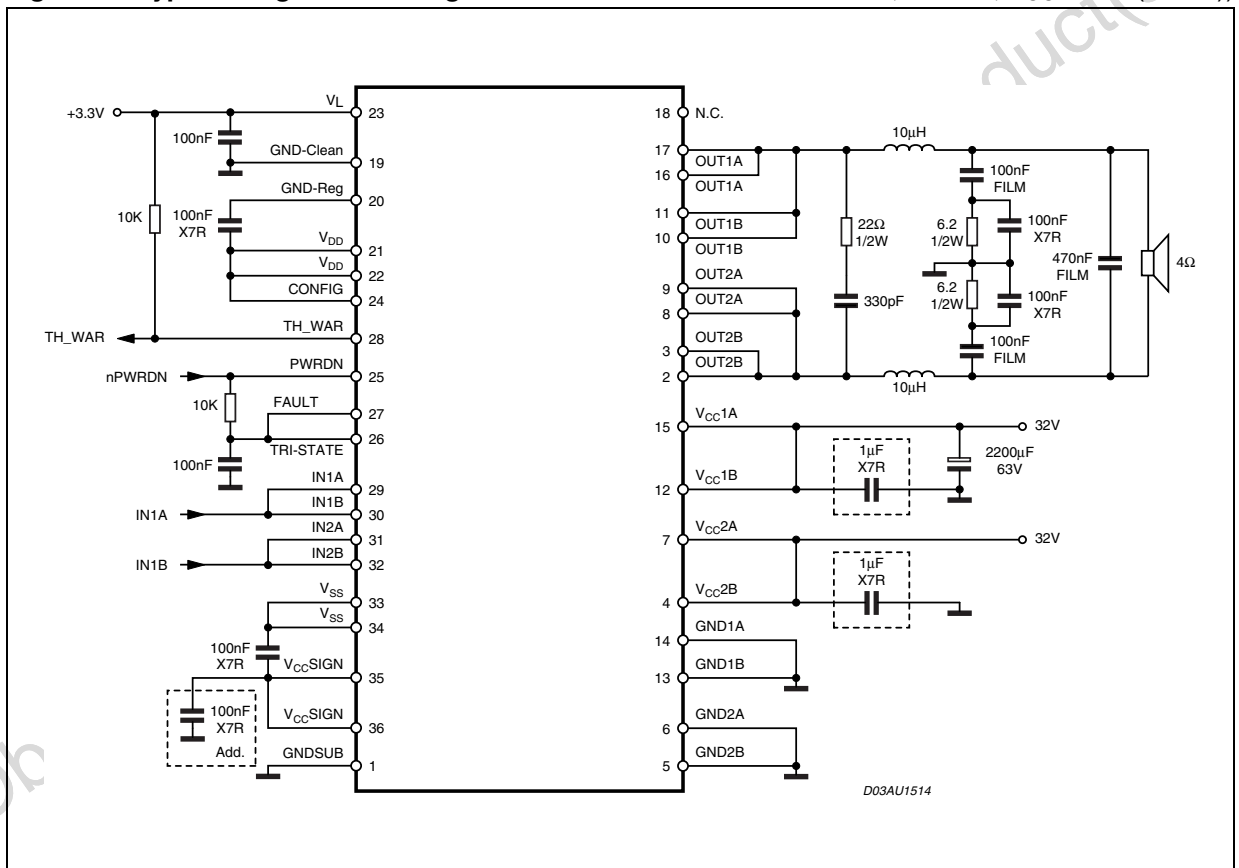
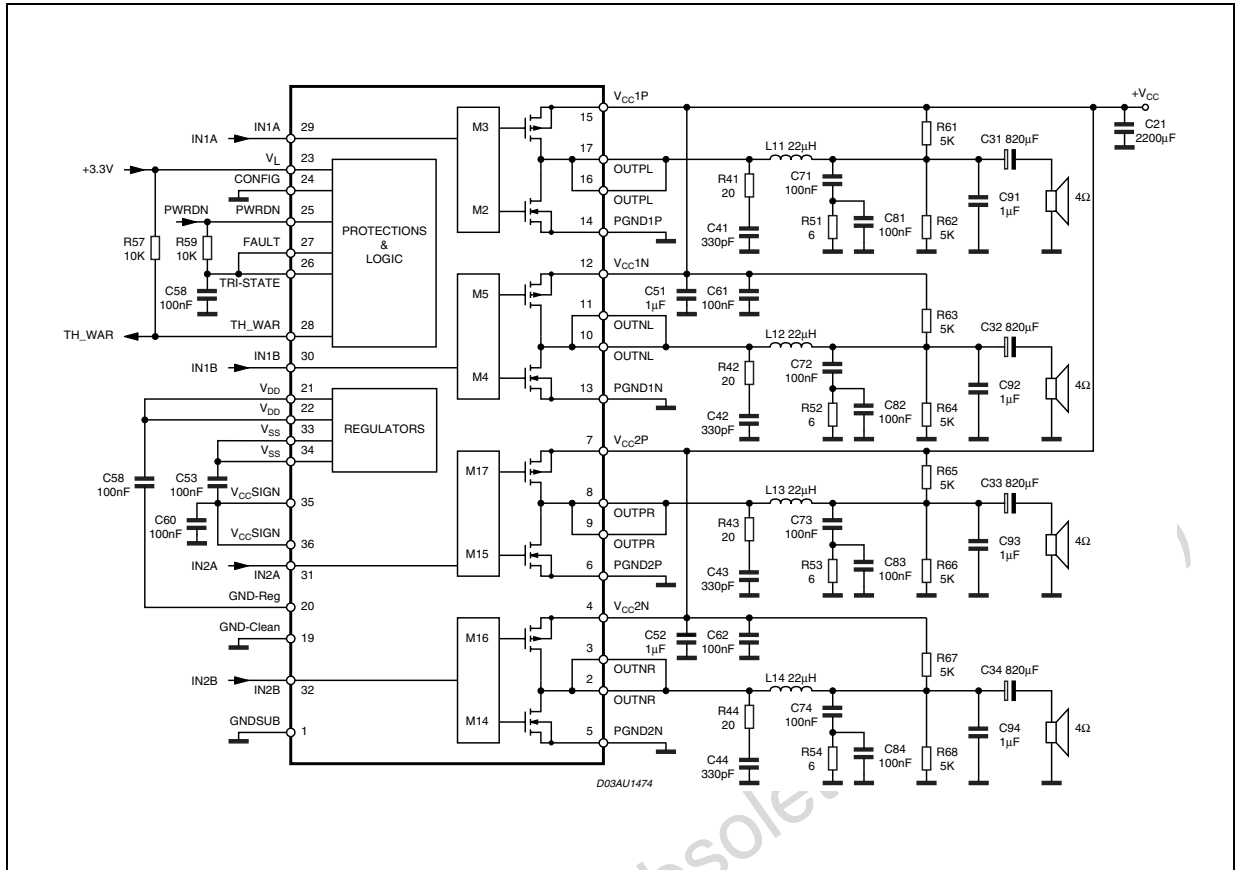

Figure 10. Typical Single BTL Configuration to Obtain 120W @ THD 10%, $R_L = 4\Omega$, $V_{CC} = 32V$ (note 1)



Note: 1. "A PWM modulator as driver is needed. In particular, this result is performed using the STA30X+STA50X demo board". Peak Power for $t \leq 1\text{sec}$

Figure 11. Typical Quad Half Bridge Configuration



For more information refer to the application notes AN1456 and AN1661

Figure 12. THD+N vs Frequency

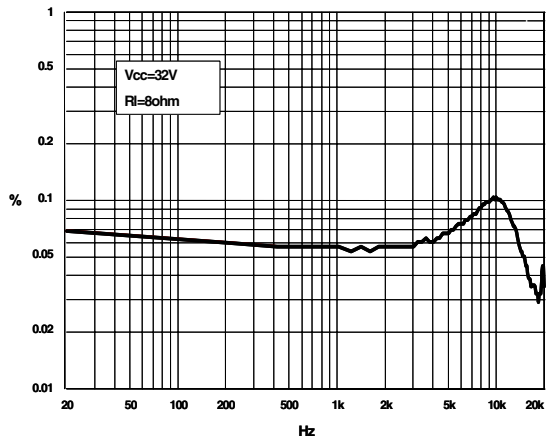

Figure 15. THD+N vs Output Power

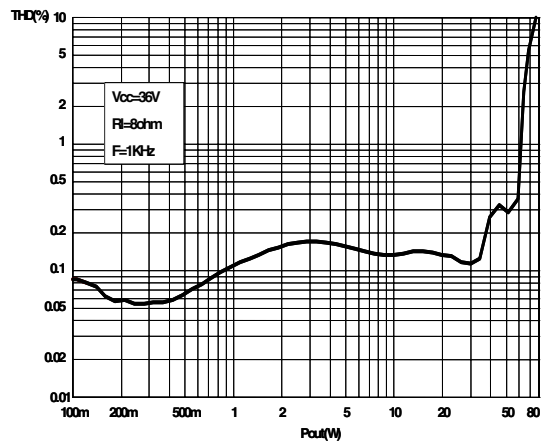

Figure 13. Output Power vs Vsupply

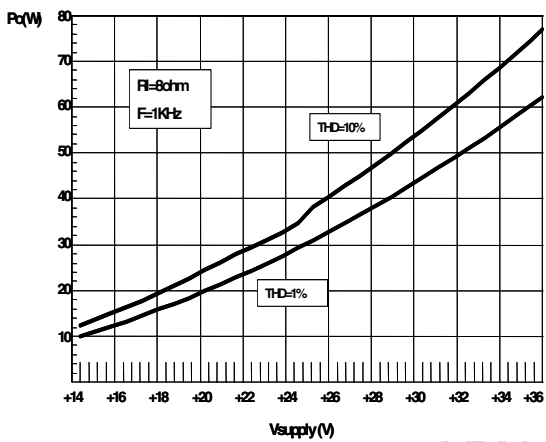

Table 10. THD+N vs Output Power

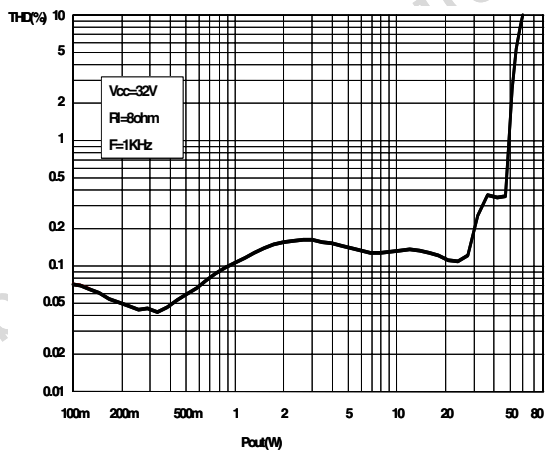

Figure 14. THD+N vs Output Power

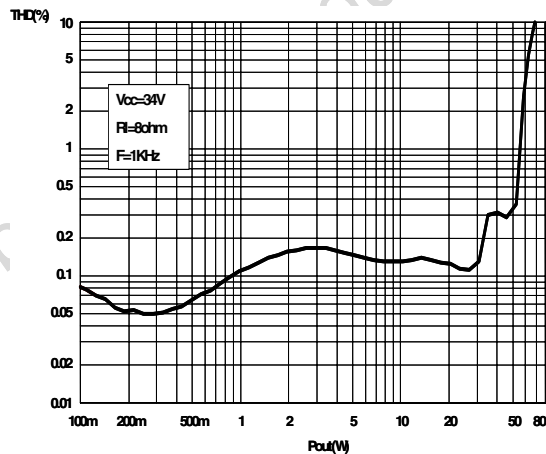
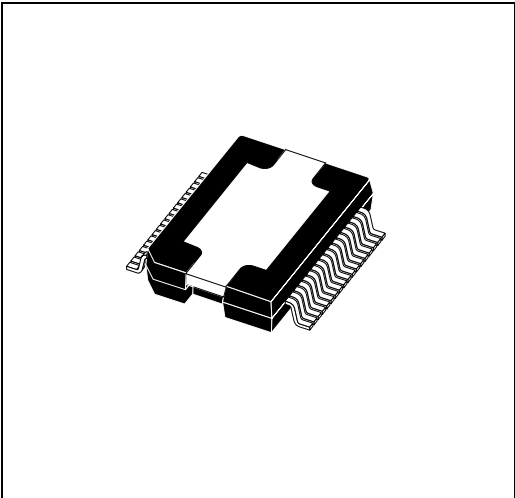

Figure 16. Power SO36 (Slug Up) Mechanical Data & Package Dimensions

DIM.	mm			inch		
	MIN.	TYP.	MAX.	MIN.	TYP.	MAX.
A	3.25		3.43	0.128		0.135
A2	3.1		3.2	0.122		0.126
A4	0.8		1	0.031		0.039
A5		0.2			0.008	
a1	0.030		-0.040	0.0011		-0.0015
b	0.22		0.38	0.008		0.015
c	0.23		0.32	0.009		0.012
D	15.8		16	0.622		0.630
D1	9.4		9.8	0.37		0.38
D2		1			0.039	
E	13.9		14.5	0.547		0.57
E1	10.9		11.1	0.429		0.437
E2			2.9			0.114
E3	5.8		6.2	0.228		0.244
E4	2.9		3.2	0.114		1.259
e		0.65			0.026	
e3		11.05			0.435	
G	0		0.075	0		0.003
H	15.5		15.9	0.61		0.625
h			1.1			0.043
L	0.8		1.1	0.031		0.043
N			10°			10°
s			8°			8°

OUTLINE AND MECHANICAL DATA



PowerSO36 (SLUG UP)

- (1) "D and E1" do not include mold flash or protusions. Mold flash or protusions shall not exceed 0.15mm (0.006")
- (2) No intrusion allowed inwards the leads.

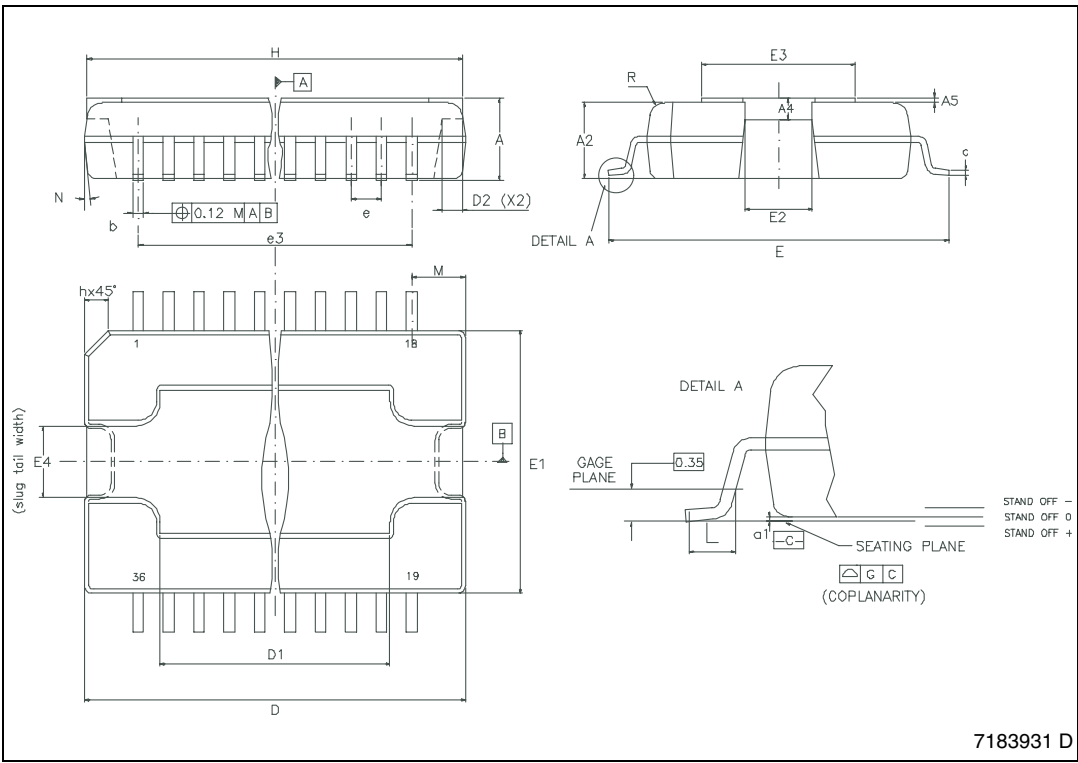

7183931 D



Table 11. Revision History

Date	Revision	Description of Changes
August 2004	1	First Issue
November 2004	2	Changed Vcc from 9 min to 10 min

Obsolete Product(s) - Obsolete Product(s)

Information furnished is believed to be accurate and reliable. However, STMicroelectronics assumes no responsibility for the consequences of use of such information nor for any infringement of patents or other rights of third parties which may result from its use. No license is granted by implication or otherwise under any patent or patent rights of STMicroelectronics. Specifications mentioned in this publication are subject to change without notice. This publication supersedes and replaces all information previously supplied. STMicroelectronics products are not authorized for use as critical components in life support devices or systems without express written approval of STMicroelectronics.

The ST logo is a registered trademark of STMicroelectronics.
All other names are the property of their respective owners

DDX is a trademark of Apogee technology inc.

© 2004 STMicroelectronics - All rights reserved

STMicroelectronics group of companies

Australia - Belgium - Brazil - Canada - China - Czech Republic - Finland - France - Germany - Hong Kong - India - Israel - Italy - Japan - Malaysia - Malta - Morocco - Singapore - Spain - Sweden - Switzerland - United Kingdom - United States of America

www.st.com