

NPN MEDIUM POWER TRANSISTORS

Features

- TO-92 PACKAGE SUITABLE FOR THROUGH-HOLE PCB ASSEMBLY
- IN COMPLIANCE WITH THE 2002/93/EC EUROPEAN DIRECTIVE

Applications

- VOLTAGE REGULATION
- RELAY DRIVER
- GENERIC SWITCH

Description

The STX724 is a NPN transistor manufactured using planar Technology resulting in rugged high performance devices.

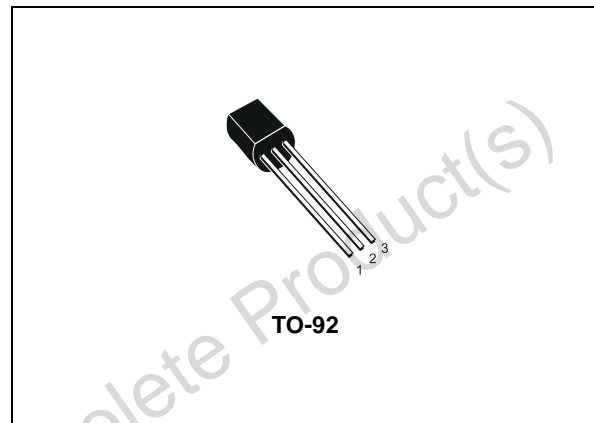

Internal Schematic Diagram

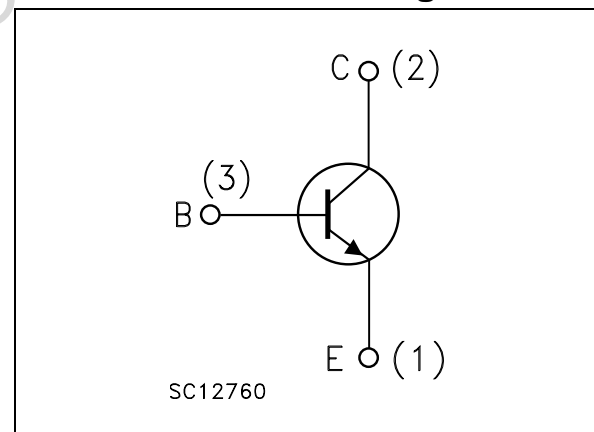

Order codes

Part Number	Marking	Package	Packing
STX724	X724	TO-92	BULK

1 Electrical Ratings

Table 1. Absolute Maximum Rating

Symbol	Parameter	Value	Unit
V_{CBO}	Collector-Base Voltage ($I_E = 0$)	60	V
V_{CEO}	Collector-Emitter Voltage ($I_B = 0$)	30	V
V_{EBO}	Collector-Base Voltage ($I_C = 0$)	5	V
I_C	Collector Current	3	A
I_{CM}	Collector Peak Current ($t_P < 5\text{ms}$)	6	A
I_B	Base Current	1	A
I_{BM}	Base Peak Current ($t_P < 5\text{ms}$)	2	A
P_{TOT}	Total dissipation at $T_C = 25^\circ\text{C}$	0.9	W
T_{STG}	Storage Temperature	-65 to 150	°C
T_J	Max. Operating Junction Temperature	150	

Table 2. Thermal Data

Symbol	Parameter	Value	Unit
$R_{thj-case}$	Thermal Resistance Junction-Case Max	44.6	°C/W
$R_{thj-amb}$	Thermal Resistance Junction-Amb Max	139	°C/W

2 Electrical Characteristics

Table 3. Electrical Characteristics ($T_{CASE} = 25^{\circ}C$; unless otherwise specified)

Symbol	Parameter	Test Conditions	Min.	Typ.	Max.	Unit
I_{CES}	Collector Cut-off Current ($V_{BE} = 0$)	$V_{CE} = 60V$			10	μA
I_{CEO}	Collector Cut-off Current ($I_B = 0$)	$V_{CE} = 30V$			100	μA
I_{EBO}	Emitter Cut-off Current ($I_C = 0$)	$V_{EB} = 5V$			10	μA
$V_{(BR)CBO}$	Collector-Base Breakdown Voltage ($I_E = 0$)	$I_C = 100\mu A$	60			V
$V_{(BR)CEO}$ <i>Note 1</i>	Collector-Emitter Breakdown Voltage ($I_B = 0$)	$I_C = 10\text{ mA}$	30			V
$V_{(BR)EBO}$	Collector-Emitter Breakdown Voltage ($I_C = 0$)	$I_E = 100\mu A$	5			V
$V_{CE(sat)}$ <i>Note 1</i>	Collector-Emitter Saturation Voltage	$I_C = 1\text{ A}$ $I_C = 2\text{ A}$ $I_C = 3\text{ A}$			0.4 0.7 1.1	V V V
$V_{BE(sat)}$ <i>Note 1</i>	Base-Emitter Saturation Voltage	$I_C = 2\text{ A}$			1.2	V
h_{FE}	DC Current Gain	$I_C = 100\text{ mA}$ $I_C = 1\text{ A}$ $I_C = 3\text{ A}$	$V_{CE} = 2\text{ V}$ $V_{CE} = 2\text{ V}$ $V_{CE} = 2\text{ V}$	100 80 30	300	
f_T	Transistor Frequency	$V_{CE} = 10\text{ V}$			100	MHz

1 Pulsed duration = 300 μs , duty cycle $\leq 1.5\%$.

2.1 Electrical characteristics (curve)

Figure 1. DC Current Gain

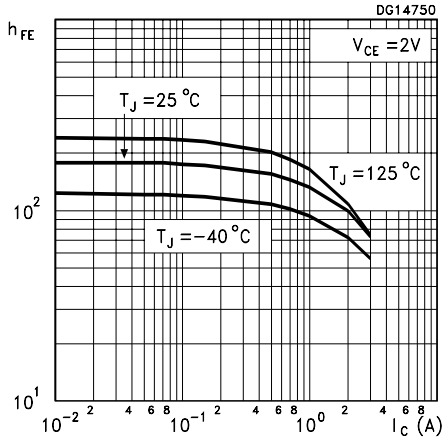

Figure 2. DC Current Gain

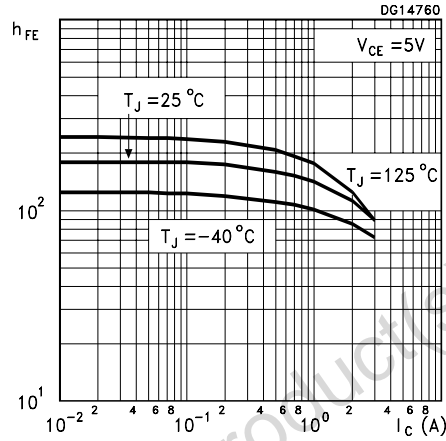

Figure 3. Collector-emitter saturation voltage Figure 4. Base-emitter saturation voltage

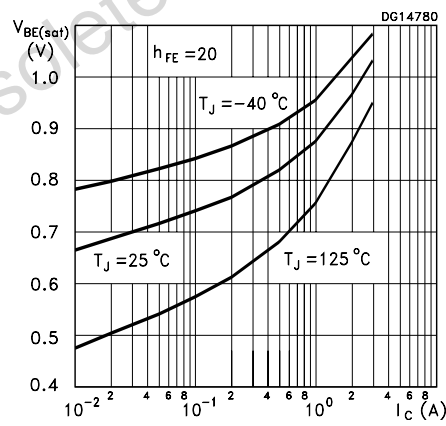
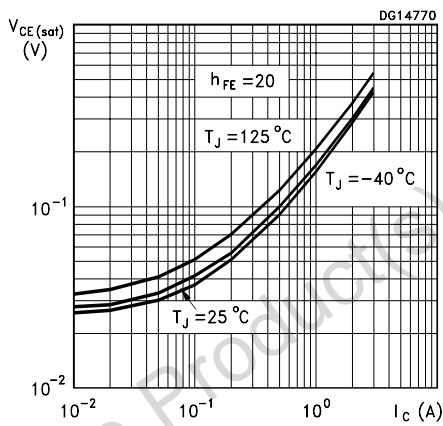

Figure 5. Switching times on resistive load

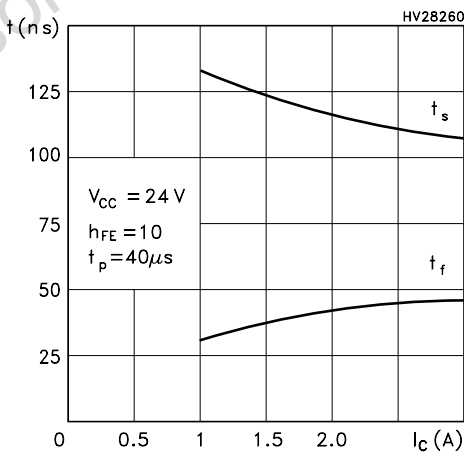

Figure 6. Switching times resistive on load

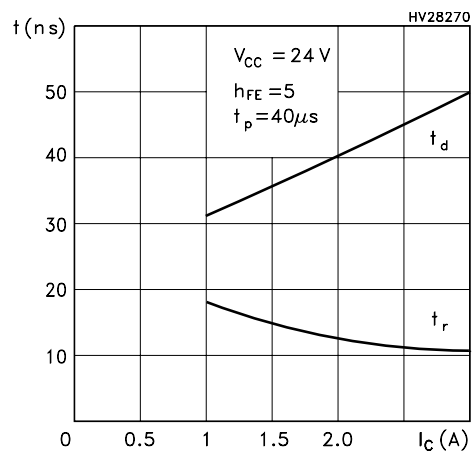
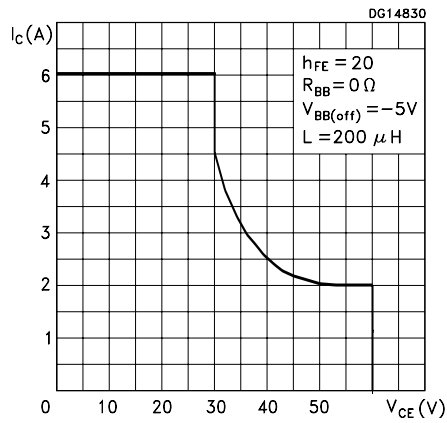

Figure 7. Reverse biased area



Obsolete Product(s) - Obsolete Product(s)

3 Package Mechanical Data

In order to meet environmental requirements, ST offers these devices in ECOPACK® packages. These packages have a Lead-free second level interconnect . The category of second level interconnect is marked on the package and on the inner box label, in compliance with JEDEC Standard JESD97. The maximum ratings related to soldering conditions are also marked on the inner box label. ECOPACK is an ST trademark. ECOPACK specifications are available at: www.st.com

Obsolete Product(s) - Obsolete Product(s)

TO-92 MECHANICAL DATA

DIM.	mm.			inch		
	MIN.	TYP.	MAX.	MIN.	TYP.	MAX.
A	4.32		4.95	0.170		0.194
b	0.36		0.51	0.014		0.020
D	4.45		4.95	0.175		0.194
E	3.30		3.94	0.130		0.155
e	2.41		2.67	0.094		0.105
e1	1.14		1.40	0.044		0.055
L	12.70		15.49	0.50		0.610
R	2.16		2.41	0.085		0.094
S1	0.92		1.52	0.036		0.060
W	0.41		0.56	0.016		0.022
V		5°			5°	

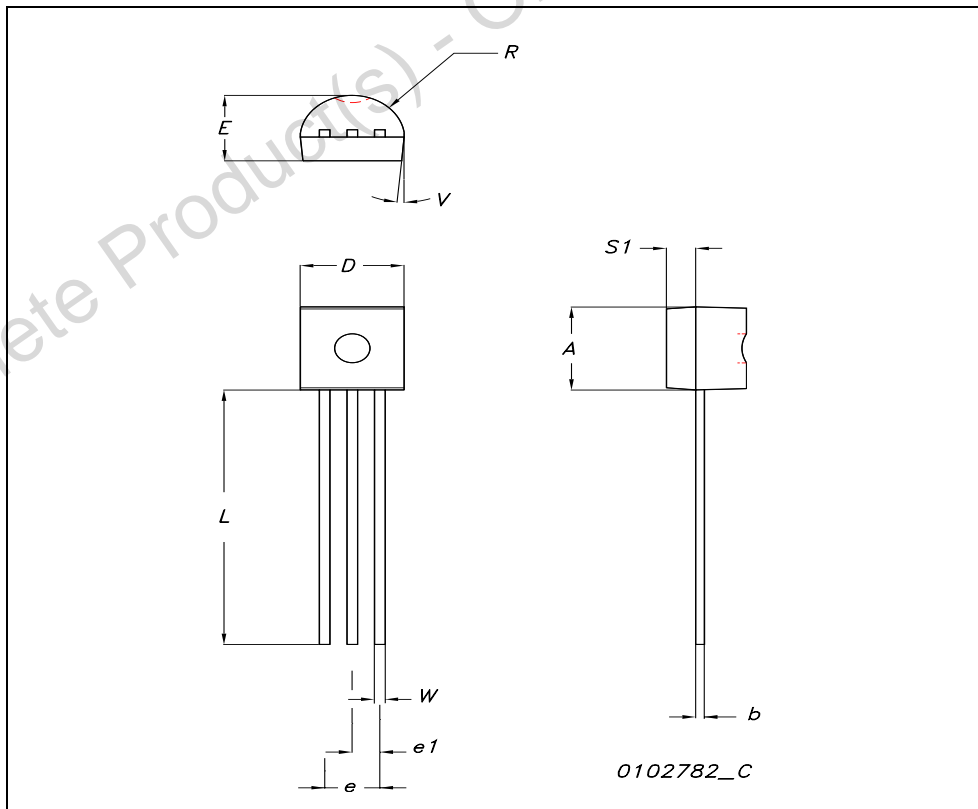

4 Revision History

Date	Revision	Changes
17-Oct-2005	1	First release

Obsolete Product(s) - Obsolete Product(s)

Obsolete Product(s) - Obsolete Product(s)

Information furnished is believed to be accurate and reliable. However, STMicroelectronics assumes no responsibility for the consequences of use of such information nor for any infringement of patents or other rights of third parties which may result from its use. No license is granted by implication or otherwise under any patent or patent rights of STMicroelectronics. Specifications mentioned in this publication are subject to change without notice. This publication supersedes and replaces all information previously supplied. STMicroelectronics products are not authorized for use as critical components in life support devices or systems without express written approval of STMicroelectronics.

The ST logo is a registered trademark of STMicroelectronics.
All other names are the property of their respective owners

© 2005 STMicroelectronics - All rights reserved

STMicroelectronics group of companies

Australia - Belgium - Brazil - Canada - China - Czech Republic - Finland - France - Germany - Hong Kong - India - Israel - Italy - Japan -
Malaysia - Malta - Morocco - Singapore - Spain - Sweden - Switzerland - United Kingdom - United States of America

www.st.com

