

## 11 W + 11 W amplifier with DC volume control

### Features

- 11 W + 11 W output power with  $R_L = 8 \Omega$ , THD = 10%,  $V_{CC} = 28 \text{ V}$
- Stand-by and mute functions
- Low turn-on and turn-off “pop” noise
- Linear volume control DC coupled to power operational amplifier
- No boucherot cell
- No RC input network for stand-by
- Single supply up to 35 V
- Short-circuit protection
- Thermal overload protection
- Internally fixed gain
- Soft clipping
- Variable output after volume control circuit
- Clipwatt15 package, RoHS

### Multipower BI50II technology

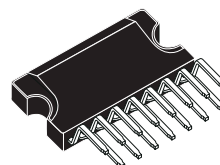

Clipwatt15

### Description

The TDA7495SA is a stereo 11 W + 11 W class AB power amplifier specially designed for high-quality sound and TV applications. Its features include linear volume control, stand-by and mute functions. The TDA7495SA is delivered in the Clipwatt15 package

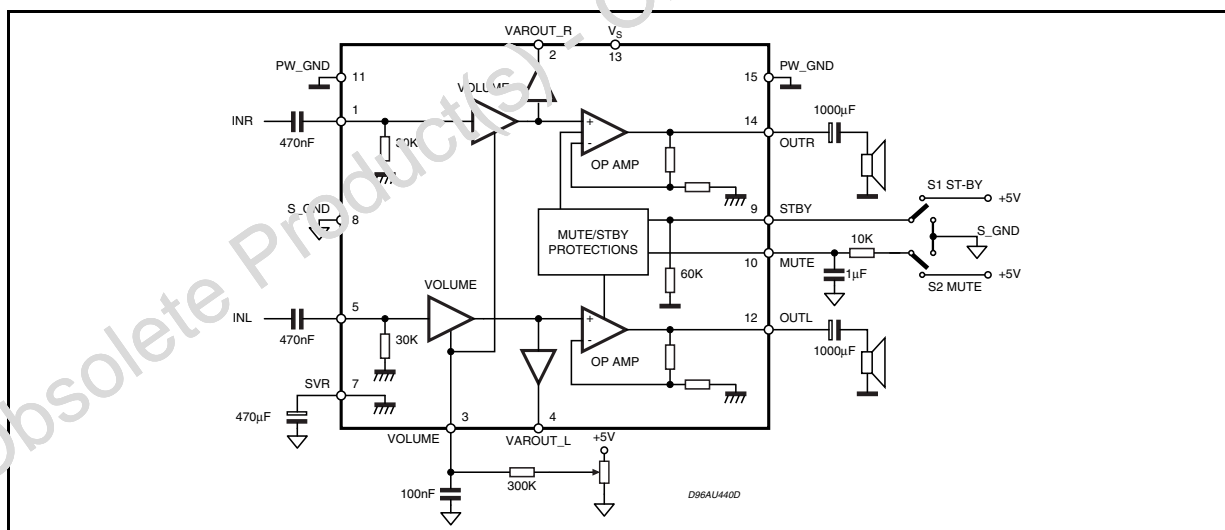

Table 1. Device summary

Order code	Package	Packaging
TDA7495SA	Clipwatt15	Tube

# 1 Pin connections

Figure 1. Pin connection (top view)

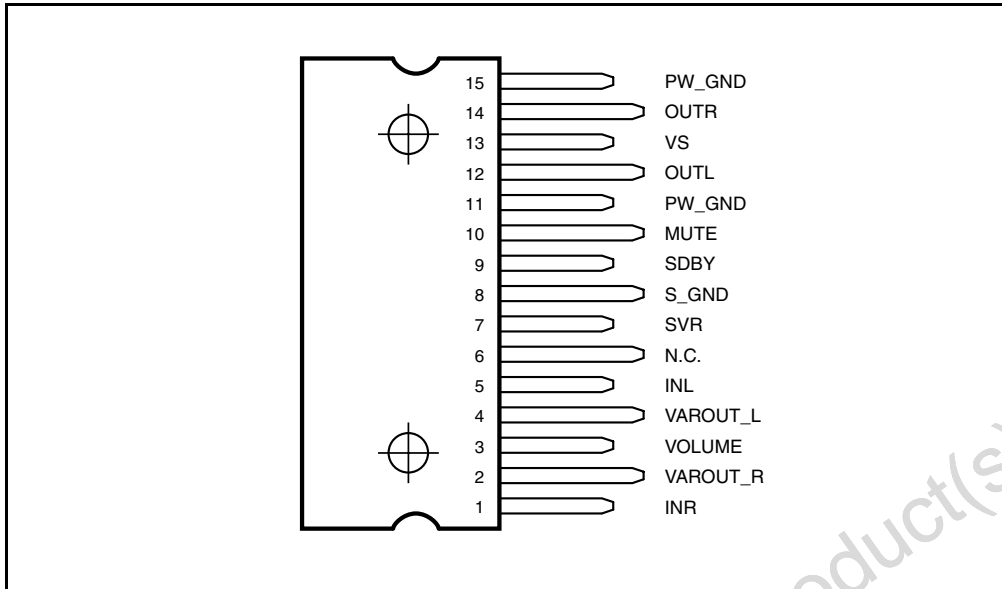

Table 2. Pin description

Number	Name	Description
1	INR	Input, right channel
2	VAROUT_R	Volume control output, right channel
3	VOLUME	Adjust volume
4	VAROUT_L	Volume control output, left channel
5	INL	Input, left channel
6	N.C.	Not connected
7	SVR	Internal half supply bias
8	S_GND	Signal ground
9	STBY	Stand-by (active high)
10	MUTE	Mute (active high)
11	PW_GND	Power ground
12	OUTL	Output, left channel
13	VS	Power supply
14	OTR	Output, right channel
15	PW_GND	Power ground

## 2 Electrical specifications

**Table 3. Absolute maximum ratings**

Symbol	Parameter	Value	Unit
$V_S$	DC supply voltage	35	V
$V_{IN}$	Maximum input voltage	8	V <sub>pp</sub>
$P_{tot}$	Total power dissipation ( $T_{amb} = 70^\circ\text{C}$ )	15	W
$T_{amb}$	Ambient operating temperature	0 to 70	$^\circ\text{C}$
$T_{stg}, T_J$	Storage and junction temperature	-40 to 150	$^\circ\text{C}$
$V_3$	Volume control DC voltage	7	V

**Table 4. Thermal data**

Symbol	Parameter	Min	Typ	Max	Unit
$R_{th\ j-case}$	Thermal resistance junction-case		4.5	5.0	$^\circ\text{C}/\text{W}$
$R_{th\ j-amb}$	Thermal resistance junction-ambient		48		$^\circ\text{C}/\text{W}$

Unless otherwise stated, the test conditions for the specifications given in [Table 5](#) below are:  $V_S = 20\text{ V}$ ,  $R_L = 8\ \Omega$ , generator resistance  $R_g = 50\ \Omega$ ,  $T_{amb} = 25^\circ\text{C}$ . Refer also to the application circuit of [Figure 2 on page 5](#).

**Table 5. Electrical characteristics**

Symbol	Parameter	Test condition	Min	Typ	Max	Unit
$V_S$	Supply voltage range		11		35	V
$I_q$	Total quiescent current			70	100	mA
$DCV_{os}$	Output DC offset referred to SVR potential	No input signal	-650		650	mV
$V_O$	Quiescent output voltage			10		V
$P_O$	Output power	THD = 10%, $V_S = 28\text{ V}$	9.5	11		W
		THD = 1%, $V_S = 28\text{ V}$	7.5	8		W
		THD = 10%, $V_S = 20\text{ V}$ , $R_L = 4\ \Omega$	7	8		W
		THD = 1%, $V_S = 20\text{ V}$ , $R_L = 4\ \Omega$	5	6		W
		THD = 10%, $V_S = 18\text{ V}$	3.5	3.8		W
		THD = 1%, $V_S = 18\text{ V}$	2.2	2.9		W
THD	Total harmonic distortion	$G_v = 30\text{ dB}$ , $P_O = 1\text{ W}$ , $f = 1\text{ kHz}$			0.4	%
$I_{peak}$	Peak output current	(internally limited)	1.7	2.4		A
$V_{IN}$	Input signal				2.8	V <sub>RMS</sub>
$R_i$	Input resistance		22.5	30		k $\Omega$
$R_{VarOut}$	Output resistance at pins VAROUT_L, VAROUT_R			30	100	$\Omega$

**Table 5. Electrical characteristics (continued)**

Symbol	Parameter	Test condition	Min	Typ	Max	Unit
R <sub>L_VarOut</sub>	Load resistance which can be connected to pins VAROUT_L, VAROUT_R		2			kΩ
G <sub>v</sub>	Closed-loop gain	VOLUME >4.5 V	28.5	30	31.5	dB
G <sub>vline</sub>	Volume control output at max gain	VOLUME > 4.5 V, R <sub>L_VarOut</sub> > 30 kΩ	-1.5	0	1.5	dB
A <sub>Min_VOL</sub>	Attenuation at minimum volume setting	VOLUME < 0.5 V	80			dB
BW				0.6		MHz
e <sub>N</sub>	Total output noise	f = 20 Hz to 22 kHz PLAY, max volume		500	800	μV
		f = 20 Hz to 22 kHz PLAY, max attenuation		100	250	μV
		f = 20 Hz to 22 kHz MUTE		60	150	μV
SR	Slew rate		5	8		V/μs
SVR	Supply voltage rejection	f = 1 kHz; max volume C <sub>SVR</sub> = 470 μF; V <sub>RIP</sub> = 1 V RMS	35	39		dB
		f = 1 kHz; max attenuation C <sub>SVR</sub> = 470 μF; V <sub>RIP</sub> = 1 V RMS	55	65		dB
TM	Thermal muting			150		°C
TS	Thermal shut-down			160		°C
<b>Mute, stand-by and input selection functions</b>						
V <sub>STBY</sub>	Stand-by threshold		2.3	2.5	2.7	V
V <sub>MUTE</sub>	Mute threshold		2.3	2.5	2.7	V
I <sub>qSTBY</sub>	Quiescent current in stand-by			0.6	1	mA
A <sub>MUTE</sub>	Mute attenuation		50	65		dB
I <sub>STBYbias</sub>	Bias current for pin STBY	In stand-by mode, V <sub>STBY</sub> = 5 V, V <sub>MUTE</sub> = 5 V		80		μA
		In play or mute mode	-20	-5		μA
I <sub>MUTEbias</sub>	Bias current for pin MUTE	In mute mode		1	5	μA
		In play mode		0.2	2	μA

### 3 Applications

#### 3.1 Circuit diagram and components

Figure 2. Application circuit

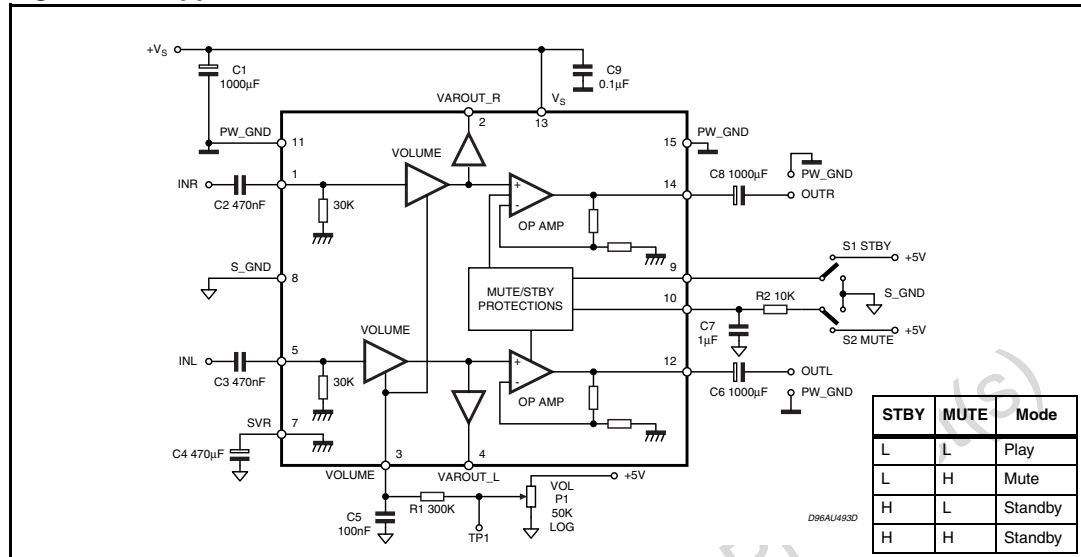

The recommended values of the external components are those shown on the application circuit of Figure 2. Table 6 below indicates how the performance changes when component values different to the recommended are used.

Table 6. Application suggestions

Symbol	Suggested value	Purpose	Larger than suggestion	Smaller than suggestion
R1	300 kΩ	Volume control circuit	Larger volume regulation time	Smaller volume regulation time
R2	10 kΩ	Mute time constant	Larger mute on/off time	Smaller mute on/off time
P1	50 kΩ	Volume control		
C1	1000 µF	Supply voltage decoupling		Danger of oscillation
C2, C3	470 nF	Input AC coupling	Lower low-frequency cutoff	Higher low-frequency cutoff
C4	470 µF	Ripple rejection	Better SVR	Worse SVR
C5	100 nF	Volume control time constant	Larger volume regulation time	Smaller volume regulation time
C6, C8	1000 µF	Output AC coupling	Lower low-frequency cutoff	Higher low-frequency cutoff
C7	1 µF	Mute time constant	Larger mute on/off time	Smaller mute on/off time
C9	100 nF	Supply voltage decoupling		Danger of oscillation



### 3.3 Power-up/down sequence

In order to reduce the loud speaker “pop” noise when switching the device on or off we recommend that you follow the sequence of operations shown in [Figure 6](#) below.

**Figure 6. Recommended sequence using mute and stand-by functions**

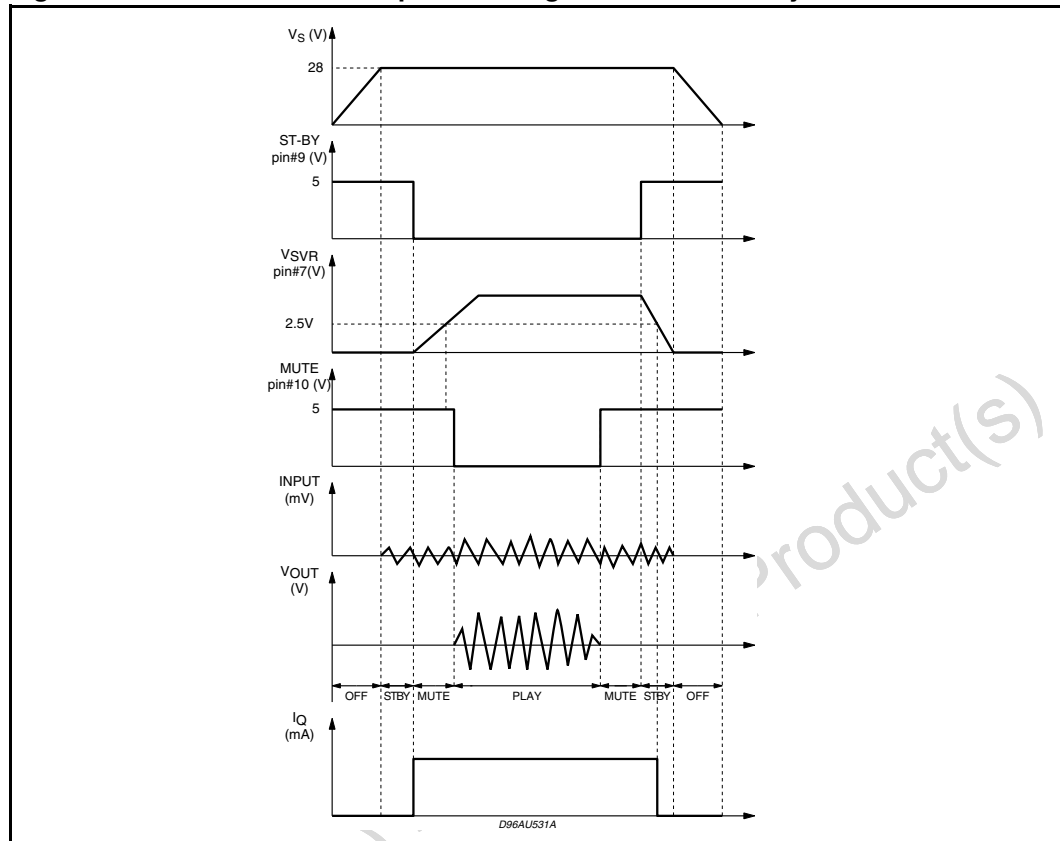

#### Using the mute function only

To simplify the application, pin STBY can be connected directly to ground so that the device is always active. Then, to maintain the power-up/down performance you should adhere to the following conditions:

- At turn-on the transition mute to play must be made when pin SVR is higher than 2.5 V.
- At turn-off the TDA7495SA must be set to mute from the play condition before pin SVR falls below 2.5 V.

### 3.4 Typical electrical characteristics

Unless otherwise stated, the test conditions for the electrical characteristics given in the figures below are:  $V_S = 20\text{ V}$ ,  $R_L = 8\ \Omega$ ,  $f = 1\text{ kHz}$ , generator resistance  $R_g = 50\ \Omega$ ,  $T_{amb} = 25^\circ\text{ C}$ . Refer also to the application circuit of [Figure 2 on page 5](#).

**Figure 7. Output power vs supply voltage**

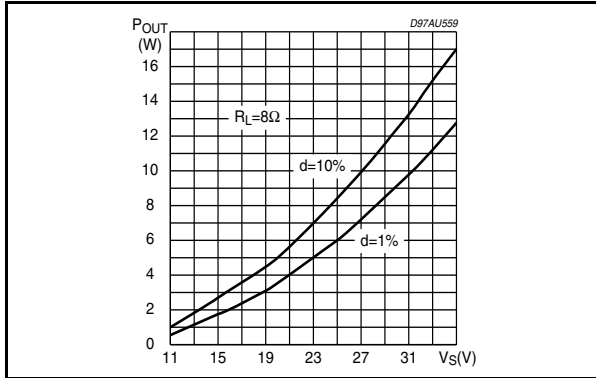

**Figure 8. Distortion vs output power**

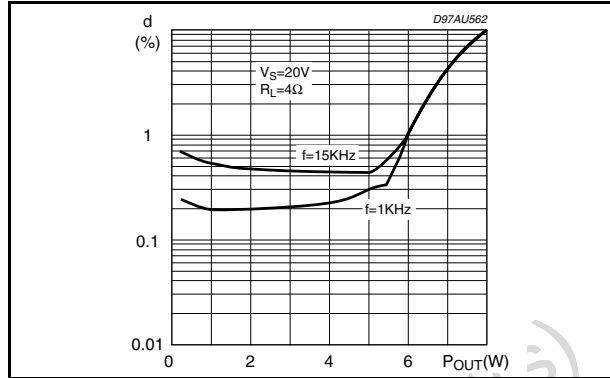

**Figure 9. Distortion vs output power**

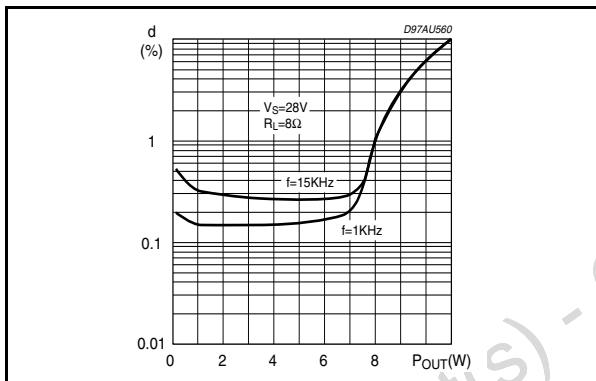

**Figure 10. Stand-by attenuation vs Vpin#9**

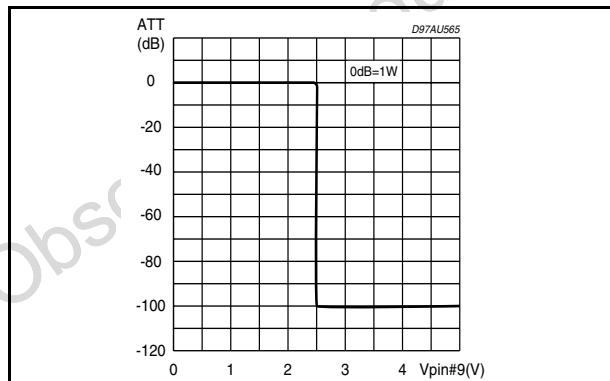

**Figure 11. Output power vs supply voltage**

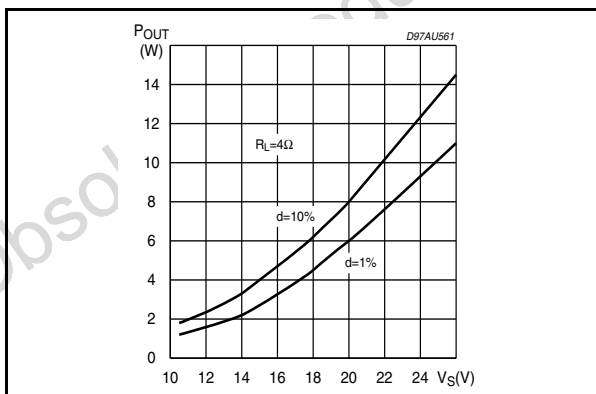

**Figure 12. Mute attenuation vs Vpin#10**

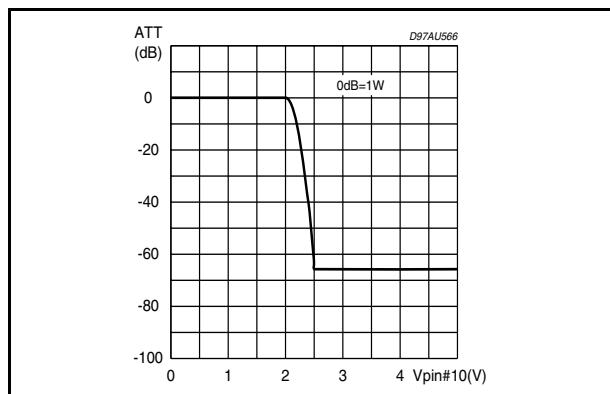

Figure 13. Supply voltage vs frequency

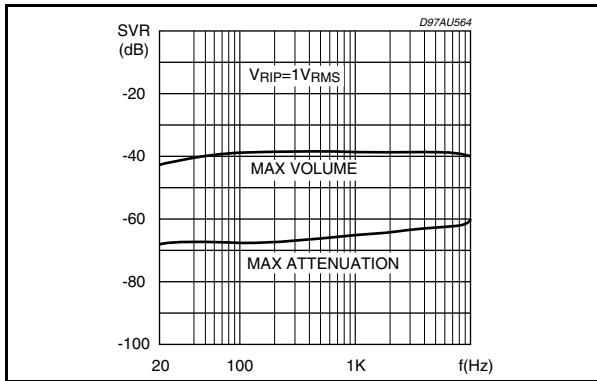

Figure 14. Gain vs volume control voltage (#3)

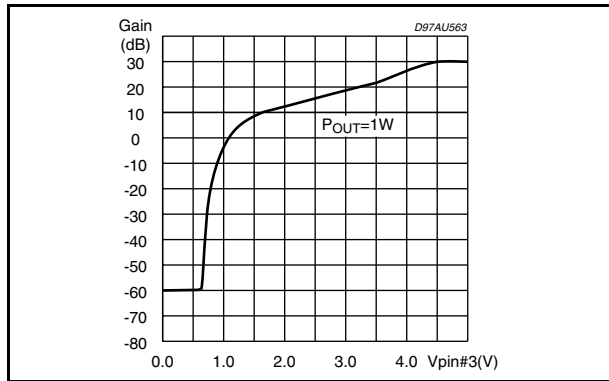

Figure 15. Power dissipation vs output power

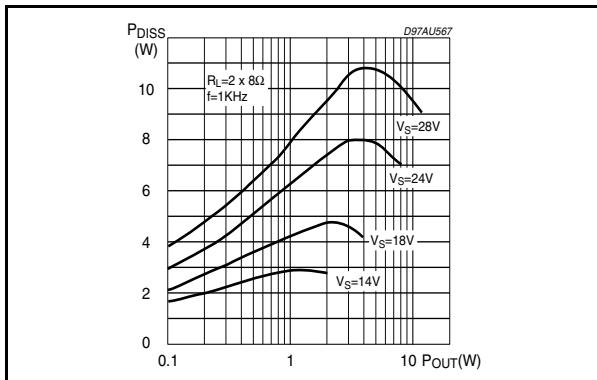
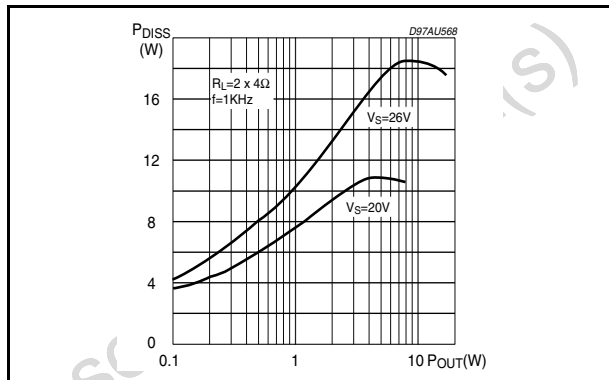

Figure 16. Power dissipation vs output power



### 3.5 Internal equivalent circuits

Figure 17. Pin: SVR

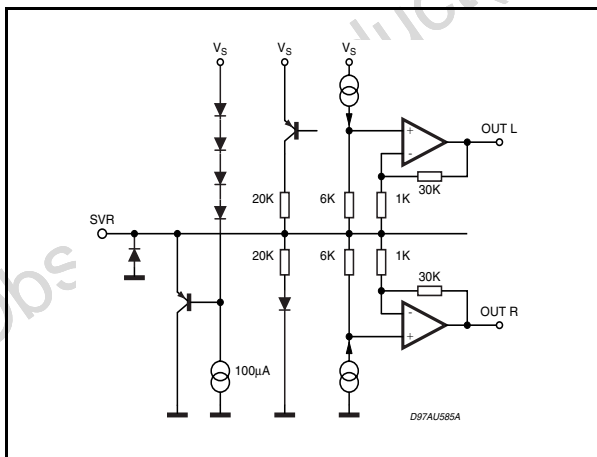

Figure 18. Pins: INL, INR

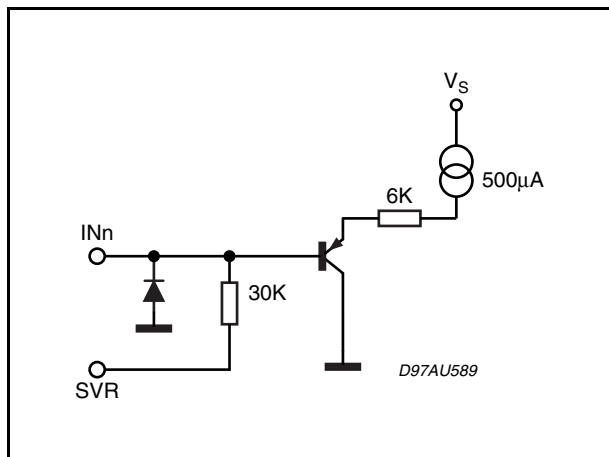

Figure 19. Pins: PW-GND, S-GND

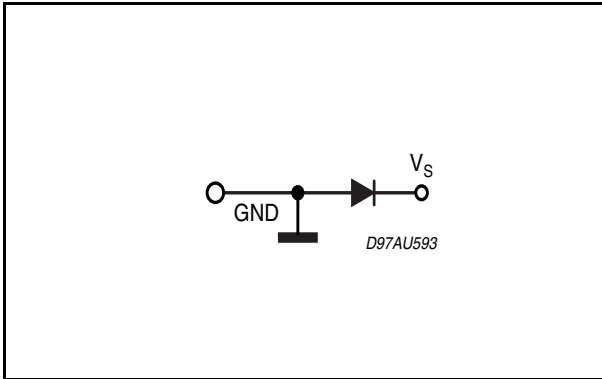

Figure 20. Pin: STBY

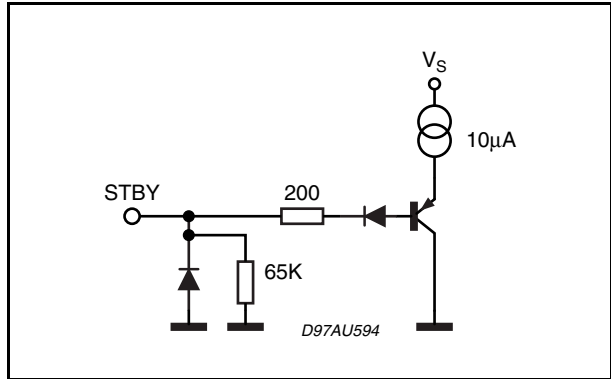

Figure 21. Pin: MUTE

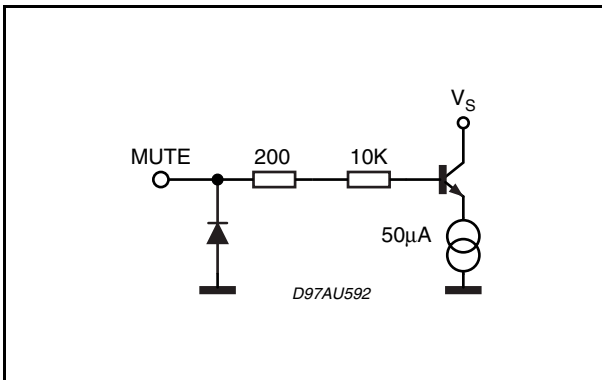

Figure 22. Pins: OUTR, OUTL

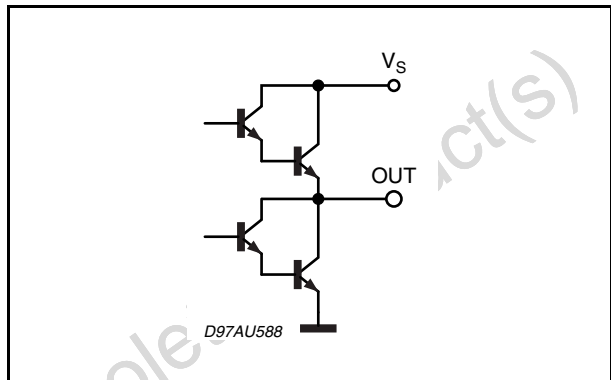

Figure 23. Pins: VAROUT\_L, VAROUT\_R

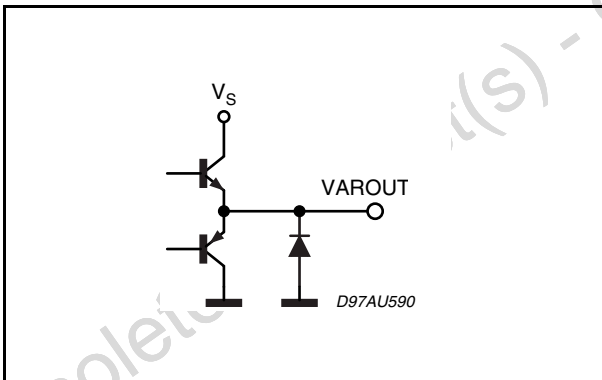
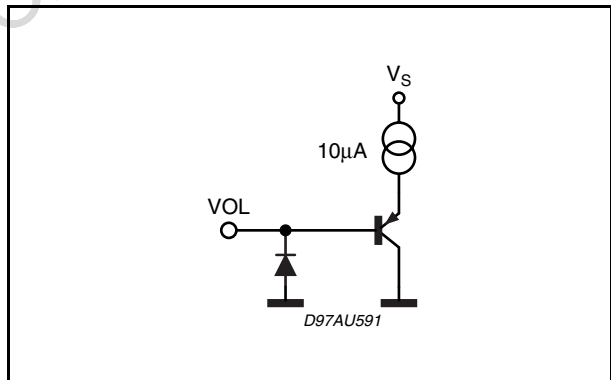

Figure 24. Pin: VOLUME



## 4 Thermal considerations

In order to avoid the intervention of the thermal protection, it is important to choose an adequate heatsink.

The parameters that influence the heatsink size are:

- maximum dissipated power for the device ( $P_{dmax}$ )
- maximum thermal resistance junction to case ( $R_{Th\ j-c}$ )
- maximum ambient temperature  $T_{amb\_max}$

Example:

For  $V_{CC} = 20\text{ V}$ ,  $R_L = 8\ \Omega$ ,  $R_{Th\ j-c} = 5^\circ\text{C/W}$ ,  $T_{amb\_max} = 50^\circ\text{C}$

$$P_{dmax} = \text{Number\_of\_channels} * \frac{V_{CC}^2}{2\pi^2 \cdot R_L} = 5\text{ W}$$

For the heatsink,

$$R_{Th\ j-c} = \frac{150 - T_{amb\_max}}{P_{d\ max}} - R_{Th\ j-c} = \frac{100}{5} - 5 = 15^\circ\text{C/W}$$

Figure 25 shows the power derating curve for the device.

Figure 25. Power derating curve

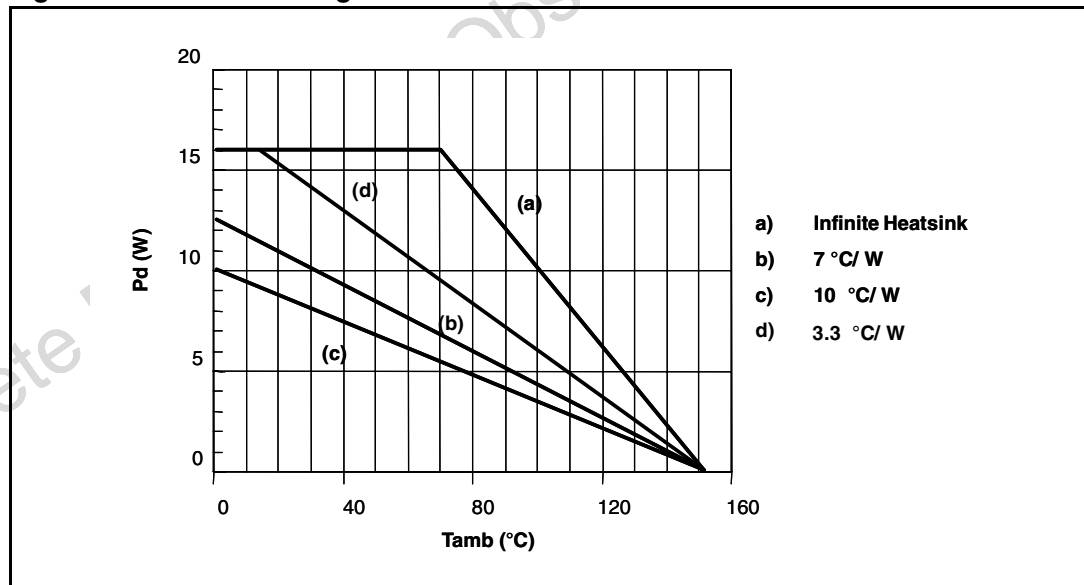

## 5 Clipwatt mounting suggestions

The suggested method for securing the Clipwatt package on an external heat sink is by a spring clip placed as close as possible to the center of the plastic body, as indicated in the example of [Figure 26](#).

Thermal grease can be used to further reduce the thermal resistance of the contact between package and heatsink.

The clip should apply a force of 7 - 10 kg to provide sufficient pressure for a good contact. Care must be taken to ensure that the contact pressure on the package does not exceed 15 kg/mm<sup>2</sup>.

As an example, if the clip applies a 15-kg force on the package then the clip must have a contact area of at least 1 mm<sup>2</sup>.

**Figure 26. Example of correctly placed clip**

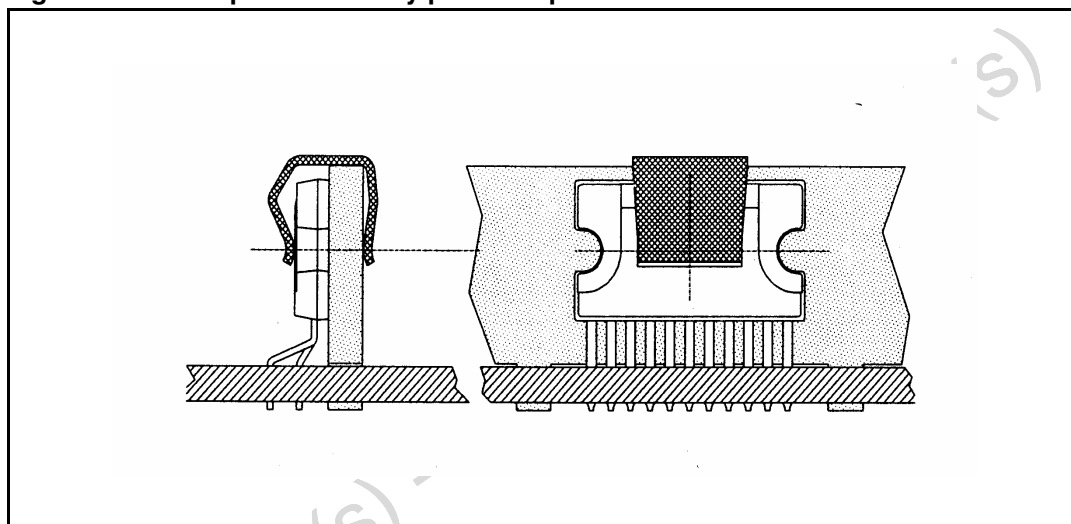

## 6 Package information

In order to meet environmental requirements, ST offers these devices in ECOPACK® packages. These packages have a Lead-free second level interconnect. The category of second Level Interconnect is marked on the package and on the inner box label, in compliance with JEDEC Standard JESD97. The maximum ratings related to soldering conditions are also marked on the inner box label. ECOPACK is an ST trademark. ECOPACK specifications are available at: [www.st.com](http://www.st.com).

DIM.	mm			inch		
	MIN.	TYP.	MAX.	MIN.	TYP.	MAX.
A			3.2			0.126
B			1.05			0.041
C		0.15			0.006	
D		1.50			0.061	
E	0.49		0.55	0.019		0.022
F	0.67		0.73	0.026		0.029
G	1.14	1.27	1.4	0.045	0.050	0.055
G1	17.57	17.78	17.91	0.692	0.700	0.705
H1		12			0.480	
H2		18.6			0.732	
H3	19.85			0.781		
L		17.9			0.704	
L1		14.55			0.572	
L2	10.7	11	11.2	0.421	0.433	0.441
L3		5.5			0.217	
M		2.54			0.100	
M1		2.54			0.100	

Outline and mechanical data

---

Weight: 1.92gr

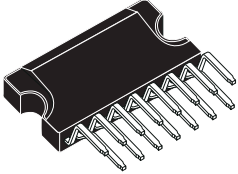

**Clipwatt15**

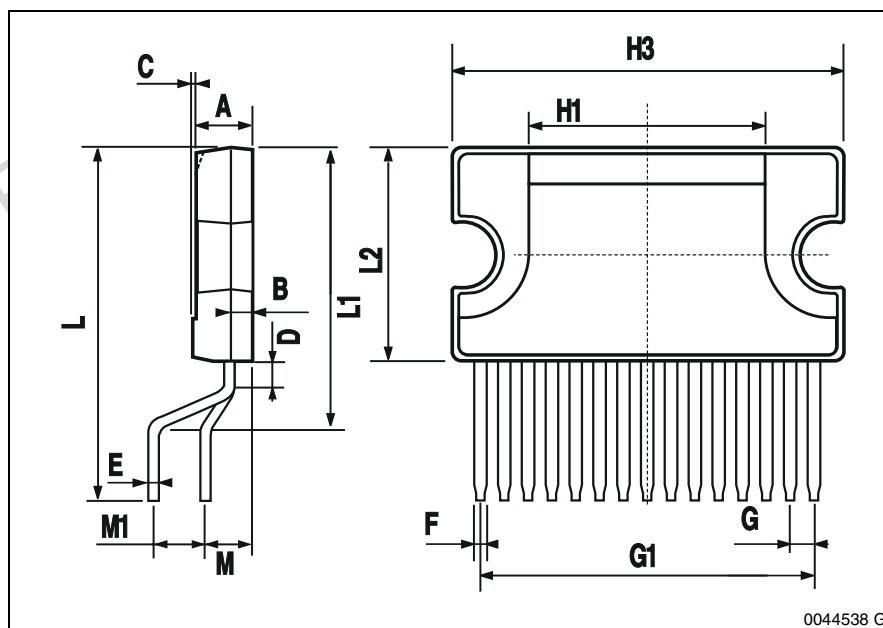

## 7 Revision history

**Table 7.Document revision history**

<b>Date</b>	<b>Revision</b>	<b>Description</b>
Sep 2003	1	Initial release
11-Dec 2007	2	Updated package and PCB information

Obsolete Product(s) - Obsolete Product(s)

**Please Read Carefully:**

Information in this document is provided solely in connection with ST products. STMicroelectronics NV and its subsidiaries ("ST") reserve the right to make changes, corrections, modifications or improvements, to this document, and the products and services described herein at any time, without notice.

All ST products are sold pursuant to ST's terms and conditions of sale.

Purchasers are solely responsible for the choice, selection and use of the ST products and services described herein, and ST assumes no liability whatsoever relating to the choice, selection or use of the ST products and services described herein.

No license, express or implied, by estoppel or otherwise, to any intellectual property rights is granted under this document. If any part of this document refers to any third party products or services it shall not be deemed a license grant by ST for the use of such third party products or services, or any intellectual property contained therein or considered as a warranty covering the use in any manner whatsoever of such third party products or services or any intellectual property contained therein.

**UNLESS OTHERWISE SET FORTH IN ST'S TERMS AND CONDITIONS OF SALE ST DISCLAIMS ANY EXPRESS OR IMPLIED WARRANTY WITH RESPECT TO THE USE AND/OR SALE OF ST PRODUCTS INCLUDING WITHOUT LIMITATION IMPLIED WARRANTIES OF MERCHANTABILITY, FITNESS FOR A PARTICULAR PURPOSE (AND THEIR EQUIVALENTS UNDER THE LAWS OF ANY JURISDICTION), OR INFRINGEMENT OF ANY PATENT, COPYRIGHT OR OTHER INTELLECTUAL PROPERTY RIGHT.**

**UNLESS EXPRESSLY APPROVED IN WRITING BY AN AUTHORIZED ST REPRESENTATIVE, ST PRODUCTS ARE NOT RECOMMENDED, AUTHORIZED OR WARRANTED FOR USE IN MILITARY, AIR CRAFT, SPACE, LIFE SAVING, OR LIFE SUSTAINING APPLICATIONS, NOR IN PRODUCTS OR SYSTEMS WHERE FAILURE OR MALFUNCTION MAY RESULT IN PERSONAL INJURY, DEATH, OR SEVERE PROPERTY OR ENVIRONMENTAL DAMAGE. ST PRODUCTS WHICH ARE NOT SPECIFIED AS "AUTOMOTIVE GRADE" MAY ONLY BE USED IN AUTOMOTIVE APPLICATIONS AT USER'S OWN RISK.**

Resale of ST products with provisions different from the statements and/or technical features set forth in this document shall immediately void any warranty granted by ST for the ST product or service described herein and shall not create or extend in any manner whatsoever, any liability of ST.

ST and the ST logo are trademarks or registered trademarks of ST in various countries.

Information in this document supersedes and replaces all information previously supplied.

The ST logo is a registered trademark of STMicroelectronics. All other names are the property of their respective owners.

© 2007 STMicroelectronics - All rights reserved

STMicroelectronics group of companies

Australia - Belgium - Brazil - Canada - China - Czech Republic - Finland - France - Germany - Hong Kong - India - Israel - Italy - Japan - Malaysia - Malta - Morocco - Singapore - Spain - Sweden - Switzerland - United Kingdom - United States of America

[www.st.com](http://www.st.com)