



STK30NHS3LL

N-channel 30 V - 0.0028 Ω - 30 A - PolarPAK[®]
 STripFET[™] Power MOSFET plus monolithic Schottky

Preliminary Data

Features

Type	V _{DSS}	R _{DS(on)}	R _{DS(on)} *Q _g	P _{TOT}
STK30NHS3LL	30V	<0.0035 Ω	87.5nC*m Ω	5.2W

- Ultra low top and bottom junction to case thermal resistance
- Reduced switching losses
- Reduced conduction losses
- Fully encapsulated die
- 100% Matte tin finish (in compliance with the 2002/95/EC european directive)
- PolarPAK[®] is a trademark of VISHAY

Application

- Switching applications

Description

This product utilizes the latest advanced design rules of ST's proprietary STripFET[™] technology and a proprietary process for integrating a monolithic Schottky diode. The new Power MOSFET is optimized for the most important demanding synchronous switch function in DC-DC converter for computer and telecom."

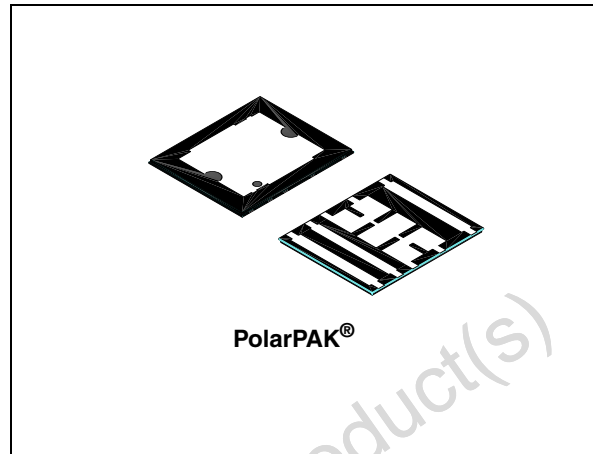

Figure 1. Internal schematic diagram

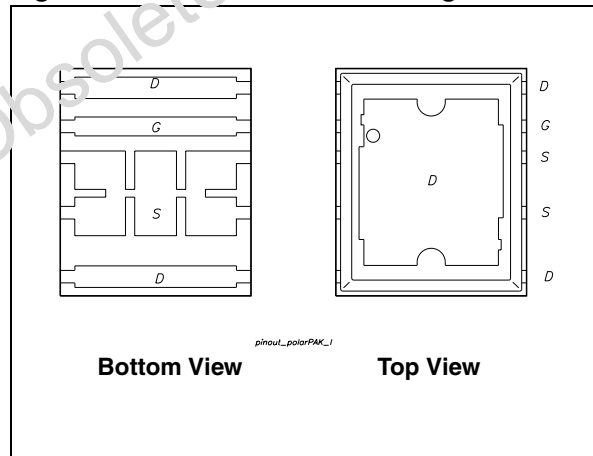

Table 1. Device summary

Order code	Marking	Package	Packaging
STK30NHS3LL	K30NKS	PolarPAK [®]	Tape & reel

Contents

1	Electrical ratings	3
2	Electrical characteristics	4
3	Test circuits	6
4	Package mechanical data	8
5	Revision history	12

Obsolete Product(s) - Obsolete Product(s)

1 Electrical ratings

Table 2. Absolute maximum ratings

Symbol	Parameter	Value	Unit
V_{DS}	Drain-source voltage ($V_{GS} = 0$)	30	V
$V_{GS}^{(1)}$	Gate-source voltage	± 16	V
$V_{GS}^{(2)}$	Gate-source voltage	± 18	V
$I_D^{(4)}$	Drain current (continuous) at $T_C = 25^\circ\text{C}$	30	A
I_D	Drain current (continuous) at $T_C = 100^\circ\text{C}$	18.75	A
$I_{DM}^{(3)}$	Drain current (pulsed)	120	A
$P_{TOT}^{(4)}$	Total dissipation at $T_C = 25^\circ\text{C}$	5.2	W
	Derating factor	0.0416	W/ $^\circ\text{C}$
$E_{AS}^{(5)}$	Single pulse avalanche energy	TBD	J
T_J T_{stg}	Operating junction temperature Storage temperature	-55 to 150	$^\circ\text{C}$

1. Continuous mode
2. Guaranteed for test time $\leq 15\text{ms}$
3. Pulse width limited by package
4. When mounted on FR-4 board of 1inch^2 , 2 oz. Cu. and $\leq 10\text{sec}$
5. Starting $T_J = 25^\circ\text{C}$, $I_D = 15\text{A}$, $V_{DD} = 25\text{V}$

Table 3. Thermal data

Symbol	Parameter	Typ.	Max.	Unit
$R_{thj-amb}^{(1)}$	Thermal resistance junction-amb	20	24	$^\circ\text{C}/\text{W}$
$R_{thj-c}^{(2)}$	Thermal resistance junction-case (top drain)	0.8	1	$^\circ\text{C}/\text{W}$
$R_{thj-c}^{(3)}$	Thermal resistance junction-case (source)	2.2	2.7	$^\circ\text{C}/\text{W}$

1. When mounted on FR-4 board of 1inch^2 , 2 oz. Cu. and $\leq 10\text{sec}$
2. Steady state
3. Measured at Source pin when the device is mounted on FR-4 board in steady state

2 Electrical characteristics

($T_{CASE}=25^{\circ}C$ unless otherwise specified)

Table 4. On/off

Symbol	Parameter	Test conditions	Min.	Typ.	Max.	Unit
$V_{(BR)DSS}$	Drain-source breakdown voltage	$I_D = 250 \mu A, V_{GS} = 0$	30			V
I_{DSS}	Zero gate voltage drain current ($V_{GS} = 0$)	$V_{DS} = \text{Max rating},$ $V_{DS} = \text{Max rating}, T_c = 125^{\circ}C$			1 10	μA μA
I_{GSS}	Gate body leakage current ($V_{DS} = 0$)	$V_{GS} = \pm 16 V$			± 100	nA
$V_{GS(th)}$	Gate threshold voltage	$V_{DS} = V_{GS}, I_D = 250 \mu A$	1		2.5	V
$R_{DS(on)}$	Static drain-source on resistance	$V_{GS} = 10 V, I_D = 15 A$ $V_{GS} = 4.5 V, I_D = 1.5 A$		0.0028 0.0033	0.0035 0.004	Ω Ω

Table 5. Dynamic

Symbol	Parameter	Test conditions	Min.	Typ.	Max.	Unit
C_{iss}	Input capacitance	$V_{DS} = 25 V, f = 1 \text{ MHz}, V_{GS} = 0$		3200		pF
C_{oss}	Output capacitance			760		pF
C_{rss}	Reverse transfer capacitance			46		pF
Q_g	Total gate charge	$V_{DD} = 15 V, I_D = 30 A$		25		nC
Q_{gs}	Gate-source charge	$V_{GS} = 4.5 V$		TBD		nC
Q_{gd}	Gate-drain charge	(see Figure 3)		TBD		nC
Q_{gs1}	Pre V_{th} gate-to-source charge	$V_{DD} = 15 V, I_D = 12 A$		TBD		nC
Q_{gs2}	Post V_{th} gate-to-source charge	$V_{GS} = 4.5 V$ (see Figure 8)		TBD		nC
R_G	Gate input resistance	$f = 1 \text{ MHz}$ Gate DC Bias = 0 Test signal level = 20 mV open drain		TBD		Ω

Table 6. Switching times

Symbol	Parameter	Test conditions	Min.	Typ.	Max.	Unit
$t_{d(on)}$ t_r	Turn-on delay time Rise time	$V_{DD}=15\text{ V}$, $I_D=15\text{ A}$, $R_G=4.7\ \Omega$, $V_{GS}=4.5\text{ V}$ <i>(see Figure 2)</i>		TBD TBD		ns ns
$t_{d(off)}$ t_f	Turn-off delay time Fall time	$V_{DD}=15\text{ V}$, $I_D=15\text{ A}$, $R_G=4.7\ \Omega$, $V_{GS}=4.5\text{ V}$ <i>(see Figure 2)</i>		TBD TBD		ns ns

Table 7. Source drain diode

Symbol	Parameter	Test conditions	Min.	Typ.	Max.	Unit
I_{SD} $I_{SDM}^{(1)}$	Source-drain current Source-drain current (pulsed)				30 120	A A
$V_{SD}^{(2)}$	Forward on voltage	$I_{SD}=3\text{ A}$, $V_{GS}=0$			0.7	V
t_{rr} Q_{rr} I_{RRM}	Reverse recovery time Reverse recovery charge Reverse recovery current	$I_{SD}=30\text{ A}$, $di/dt = 100\text{ A}/\mu\text{s}$, $V_{DD}=20\text{ V}$, $T_J=150^\circ\text{C}$ <i>(see Figure 7)</i>		TBD 30 TBD		ns nC A

1. Pulse width limited by package
2. Pulsed: pulse duration = 300µs, duty cycle 1.5%

3 Test circuits

Figure 2. Switching times test circuit for resistive load

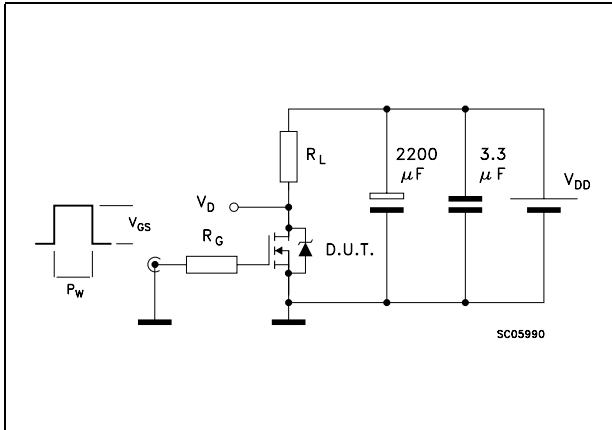

Figure 3. Gate charge test circuit

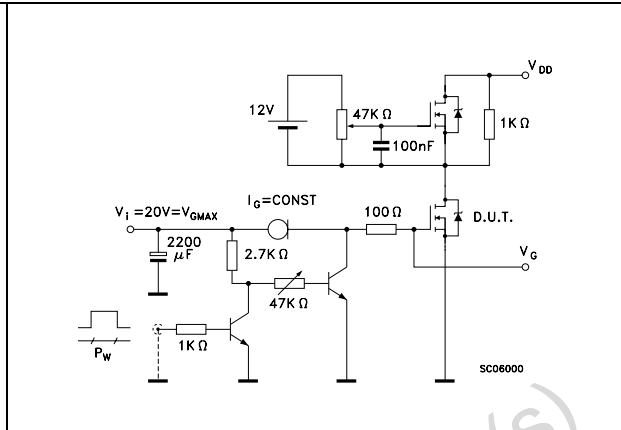

Figure 4. Test circuit for inductive load switching and diode recovery times

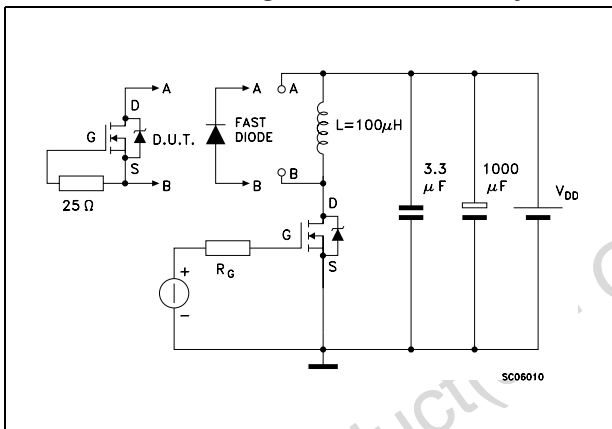

Figure 5. Unclamped inductive load test circuit

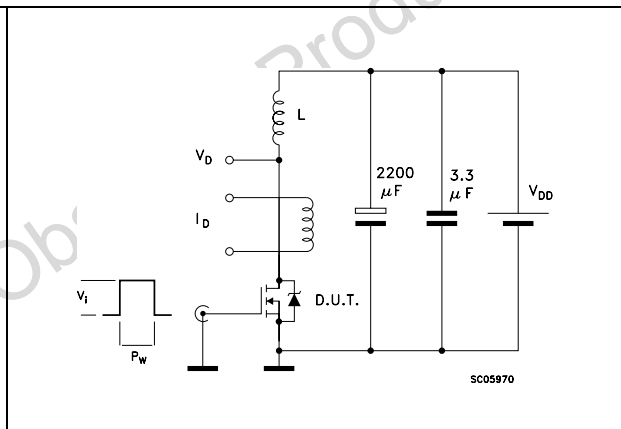

Figure 6. Unclamped inductive waveform

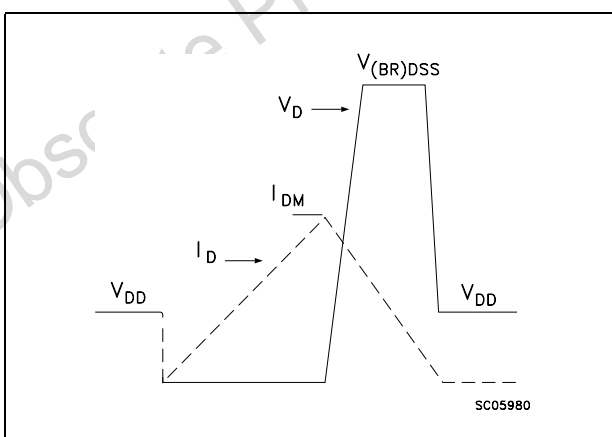

Figure 7. Switching time waveform

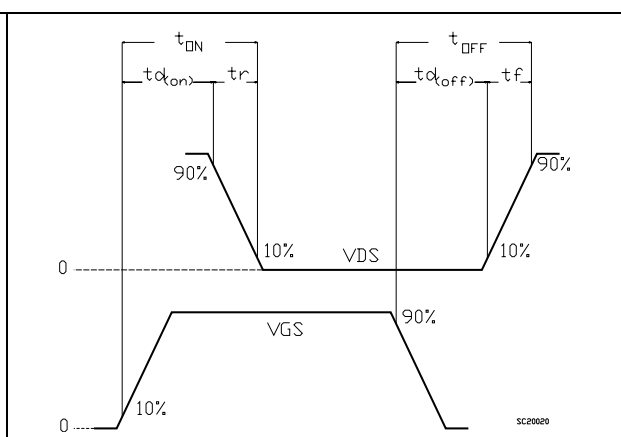
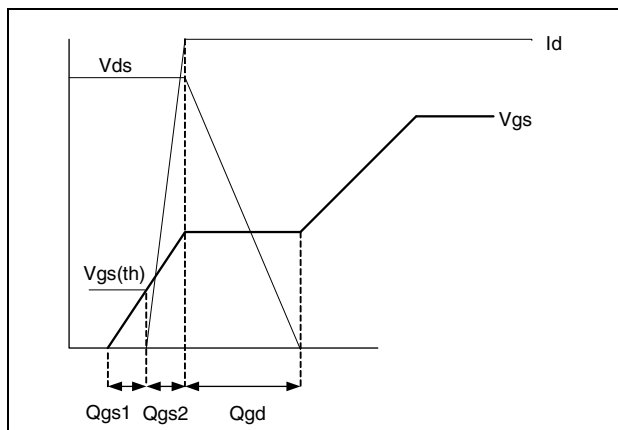

Figure 8. Gate charge waveform



Obsolete Product(s) - Obsolete Product(s)

4 Package mechanical data

In order to meet environmental requirements, ST offers these devices in ECOPACK® packages. These packages have a lead-free second level interconnect. The category of second level interconnect is marked on the package and on the inner box label, in compliance with JEDEC Standard JESD97. The maximum ratings related to soldering conditions are also marked on the inner box label. ECOPACK is an ST trademark. ECOPACK specifications are available at: www.st.com

Obsolete Product(s) - Obsolete Product(s)

Table 8. PolarPAK® (option "L") mechanical data

Ref.	mm			inch		
	Min.	Typ.	Max.	Min.	Typ.	Max.
A	0.75	0.80	0.85	0.030	0.031	0.033
A1			0.05			0.002
b1	0.48	0.58	0.68	0.019	0.023	0.027
b2	0.41	0.51	0.61	0.016	0.020	0.024
b3	2.19	2.29	2.39	0.086	0.090	0.094
b4	0.89	1.04	1.19	0.035	0.041	0.047
b5	0.23	0.33	0.43	0.009	0.013	0.017
c	0.20	0.25	0.30	0.008	0.010	0.012
D	6	6.15	6.30	0.236	0.242	0.248
D1	5.74	5.89	6.04	0.226	0.232	0.238
E	5.01	5.16	5.31	0.197	0.203	0.209
E1	4.75	4.90	5.05	0.187	0.193	0.199
H1	0.23			0.009		
H2	0.45		0.56	0.018		0.022
H3	0.31	0.41	0.51	0.012	0.016	0.020
H4	0.45		0.56	0.018		0.022
K1	4.22	4.37	4.52	0.166	0.172	0.178
K2	1.08	1.13	1.18	0.043	0.044	0.046
K3	1.37			0.054		
K4	0.24			0.009		
M1	4.30	4.50	4.70	0.169	0.177	0.185
M2	3.43	3.58	3.73	0.135	0.141	0.147
M3	0.22			0.009		
M4	0.05			0.002		
P1	0.15	0.20	0.25	0.006	0.008	0.010
T1	3.48	3.64	4.10	0.137	0.143	0.161
T2	0.56	0.76	0.95	0.022	0.030	0.037
T3	1.20			0.047		
T4	3.90			0.154		
T5		0.18	0.36		0.007	0.014
<	0°	10°	12°	0°	10°	12°

Figure 9. PolarPAK® (option "L") drawings

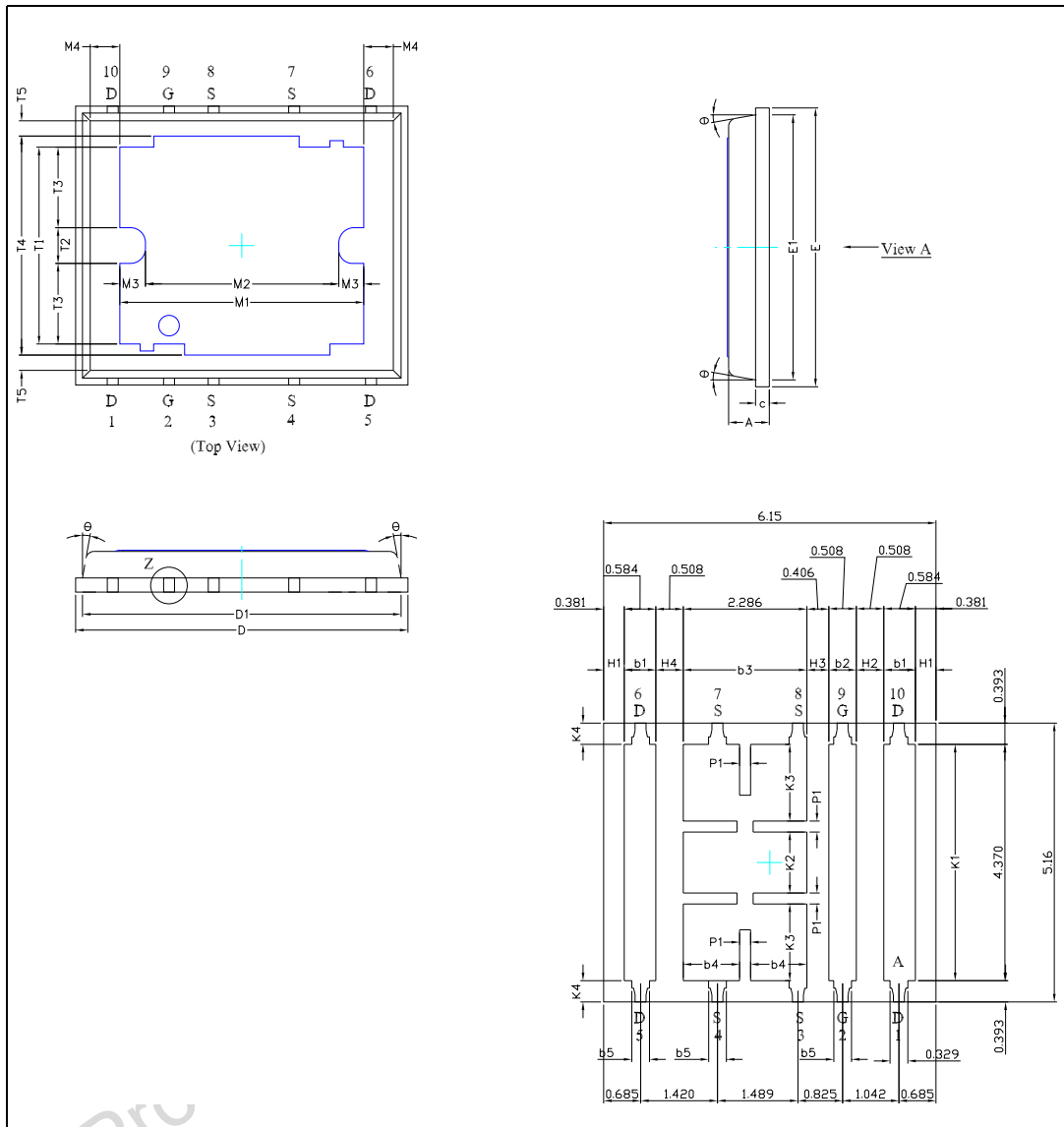

Obsolete Proc

Figure 10. Recommended PAD layout

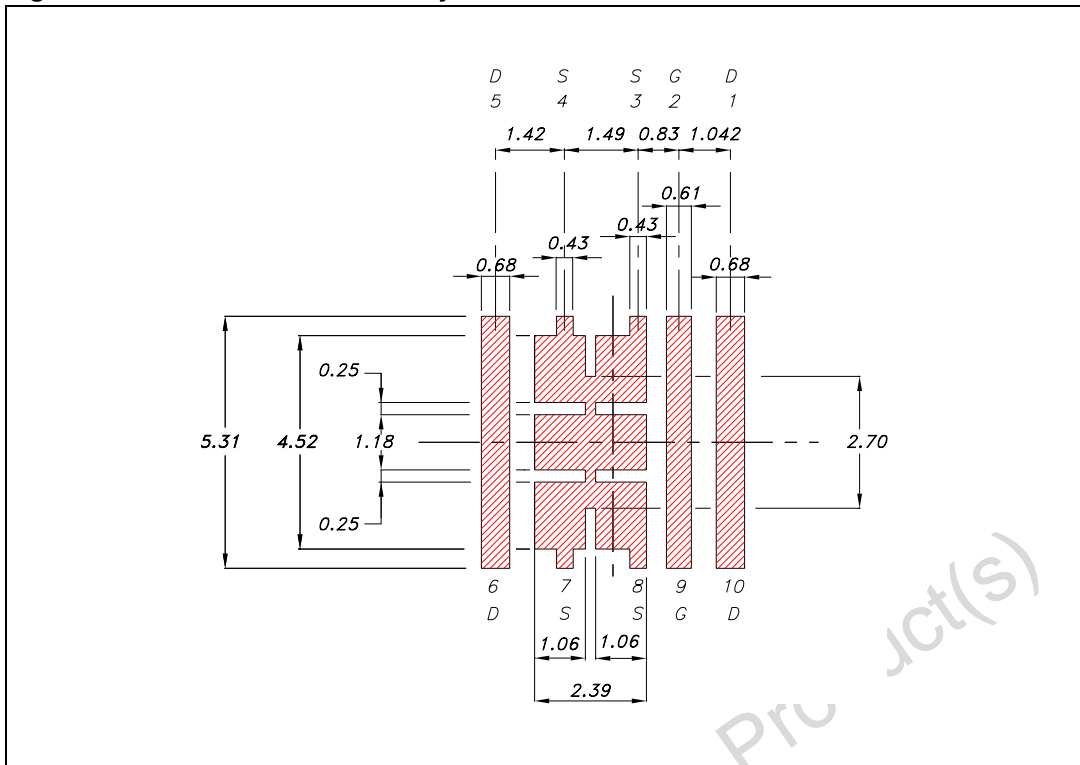

Obsolete Product(s) - Obsolete Product(s)

5 Revision history

Table 9. Document revision history

Date	Revision	Changes
19-Feb-2008	1	Initial release

Obsolete Product(s) - Obsolete Product(s)

Please Read Carefully:

Information in this document is provided solely in connection with ST products. STMicroelectronics NV and its subsidiaries ("ST") reserve the right to make changes, corrections, modifications or improvements, to this document, and the products and services described herein at any time, without notice.

All ST products are sold pursuant to ST's terms and conditions of sale.

Purchasers are solely responsible for the choice, selection and use of the ST products and services described herein, and ST assumes no liability whatsoever relating to the choice, selection or use of the ST products and services described herein.

No license, express or implied, by estoppel or otherwise, to any intellectual property rights is granted under this document. If any part of this document refers to any third party products or services it shall not be deemed a license grant by ST for the use of such third party products or services, or any intellectual property contained therein or considered as a warranty covering the use in any manner whatsoever of such third party products or services or any intellectual property contained therein.

UNLESS OTHERWISE SET FORTH IN ST'S TERMS AND CONDITIONS OF SALE ST DISCLAIMS ANY EXPRESS OR IMPLIED WARRANTY WITH RESPECT TO THE USE AND/OR SALE OF ST PRODUCTS INCLUDING WITHOUT LIMITATION IMPLIED WARRANTIES OF MERCHANTABILITY, FITNESS FOR A PARTICULAR PURPOSE (AND THEIR EQUIVALENTS UNDER THE LAWS OF ANY JURISDICTION), OR INFRINGEMENT OF ANY PATENT, COPYRIGHT OR OTHER INTELLECTUAL PROPERTY RIGHT.

UNLESS EXPRESSLY APPROVED IN WRITING BY AN AUTHORIZED ST REPRESENTATIVE, ST PRODUCTS ARE NOT RECOMMENDED, AUTHORIZED OR WARRANTED FOR USE IN MILITARY, AIR CRAFT, SPACE, LIFE SAVING, OR LIFE SUSTAINING APPLICATIONS, NOR IN PRODUCTS OR SYSTEMS WHERE FAILURE OR MALFUNCTION MAY RESULT IN PERSONAL INJURY, DEATH, OR SEVERE PROPERTY OR ENVIRONMENTAL DAMAGE. ST PRODUCTS WHICH ARE NOT SPECIFIED AS "AUTOMOTIVE GRADE" MAY ONLY BE USED IN AUTOMOTIVE APPLICATIONS AT USER'S OWN RISK.

Resale of ST products with provisions different from the statements and/or technical features set forth in this document shall immediately void any warranty granted by ST for the ST product or service described herein and shall not create or extend in any manner whatsoever, any liability of ST.

ST and the ST logo are trademarks or registered trademarks of ST in various countries.

Information in this document supersedes and replaces all information previously supplied.

The ST logo is a registered trademark of STMicroelectronics. All other names are the property of their respective owners.

© 2008 STMicroelectronics - All rights reserved

STMicroelectronics group of companies

Australia - Belgium - Brazil - Canada - China - Czech Republic - Finland - France - Germany - Hong Kong - India - Israel - Italy - Japan - Malaysia - Malta - Morocco - Singapore - Spain - Sweden - Switzerland - United Kingdom - United States of America

www.st.com