

Triple buffer/driver with open drain

Features

- 5 V tolerant inputs
- High speed: $t_{PD} = 3.7$ ns (max.) at $V_{CC} = 3.3$ V
- Low power dissipation:
 - $I_{CC} = 10$ μ A (max.) at $T_A = 85$ °C
- Power down protection on inputs and outputs
- Operating voltage range:
 - $V_{CC} (opr) = 1.65$ to 5.5 V
- Latch-up performance exceeds 300 mA (JESD 17)
- ESD performance
 - 2000-V human body model (JESD 22 A114-A)
 - 200-V machine model (JESD 22 A115-A)
 - 1000-V charge device model (JESD 22 C101)

Applications

- Mobile phones

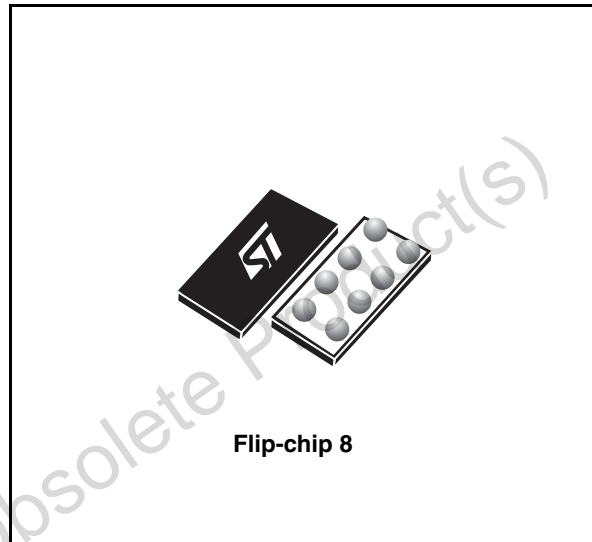

Description

The 74LX3G07 is a low voltage CMOS triple buffer/driver (open drain) fabricated with sub-micron silicon gate and double-layer metal wiring C²MOS technology.

The internal circuit composed of 2 stages including buffer output, provides high noise immunity and stable output.

Power down protection is provided on input and 0 to 7 V can be accepted on input with no regards to the supply voltage. This device can be used to interface 5 to 3 V.

Table 1. Device summary

| Order code | Package | Packaging |
|-------------|-------------|---------------|
| 74LX3G07BJR | Flip-chip 8 | Tape and reel |

1 Pin connection

Figure 1. Pin connection and IEC symbols

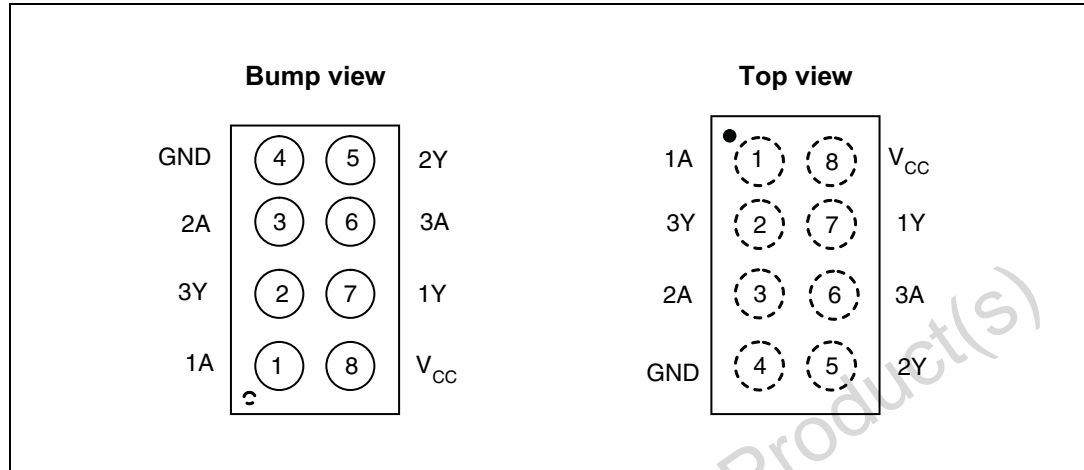

Table 2. Pin assignments

| Pin number | Symbol | Name and function |
|------------|-----------------|-------------------------|
| 1 | 1A | Data input 1 |
| 2 | 3Y | Data output 3 |
| 3 | 2A | Data input 2 |
| 4 | GND | Ground (0V) |
| 5 | 2Y | Data output 2 |
| 6 | 3A | Data input 3 |
| 7 | 1Y | Data output 1 |
| 8 | V _{CC} | Positive supply voltage |

Table 3. Truth table

| nA | nY |
|----|----|
| L | L |
| H | Z |

Z: High impedance

Figure 2. Input and output equivalent circuit

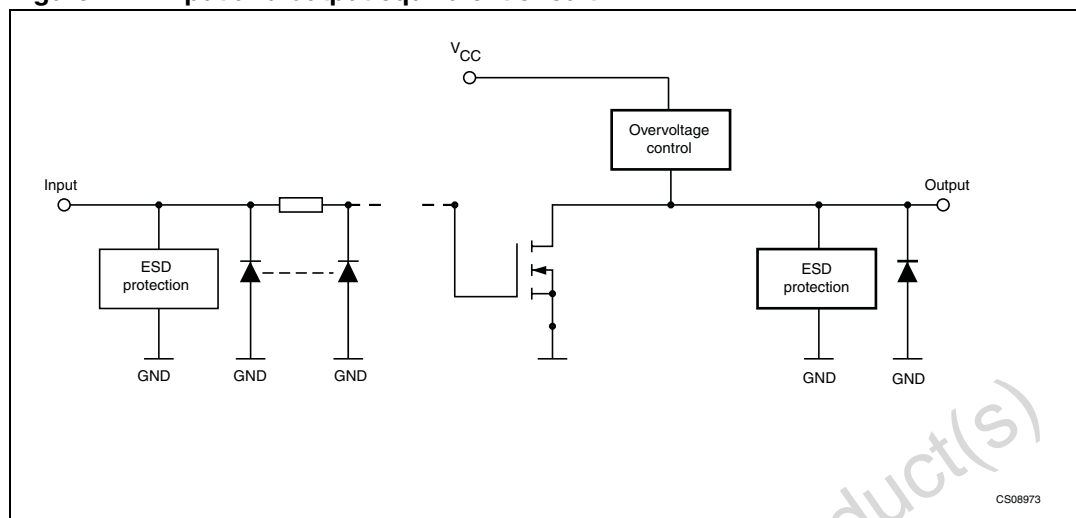

Obsolete Product(s) - Obsolete Product(s)

2 Maximum rating

Stressing the device above the rating listed in the “Absolute maximum ratings” table may cause permanent damage to the device. These are stress ratings only and operation of the device at these or any other conditions above those indicated in the operating sections of this specification is not implied. Exposure to absolute maximum rating conditions for extended periods may affect device reliability.

Table 4. Absolute maximum ratings

| Symbol | Parameter | Value | Unit |
|-----------|---------------------------------------|------------------------|------|
| V_{CC} | Supply voltage | -0.5 to +7.0 | V |
| V_I | DC input voltage | -0.5 to +7.0 | V |
| V_O | DC output voltage ($V_{CC} = 0$ V) | -0.5 to +7.0 | V |
| V_O | DC output voltage (high or low state) | -0.5 to $V_{CC} + 0.5$ | V |
| I_{IK} | DC input diode current | - 50 | mA |
| I_{OK} | DC output diode current | - 50 | mA |
| I_O | DC output current | ± 50 | mA |
| I_{CC} | DC supply current per supply pin | ± 100 | mA |
| I_{GND} | DC ground current per supply pin | ± 100 | mA |
| T_{stg} | Storage temperature | -65 to +150 | °C |
| T_L | Lead temperature (10 sec) | 300 | °C |

2.1 Recommended operating conditions

Table 5. Recommended operating conditions

| Symbol | Parameter | Value | Unit |
|----------|--|---------------|------|
| V_{CC} | Supply voltage | 1.65 to 5.5 | V |
| V_I | Input voltage | 0 to 5.5 | V |
| V_O | Output voltage ($V_{CC} = 0$ V) | 0 to 5.5 | V |
| V_O | Output voltage (high or low state) | 0 to V_{CC} | V |
| I_{OL} | High or low level output current ($V_{CC} = 4.5$ to 5.5 V) | + 32 | mA |
| I_{OL} | High or low level output current ($V_{CC} = 3.0$ to 3.6 V) | +24 | mA |
| I_{OL} | High or low level output current ($V_{CC} = 2.7$ to 3.0 V) | +12 | mA |
| I_{OL} | High or low level output current ($V_{CC} = 2.3$ to 2.7 V) | +8 | mA |
| I_{OL} | High or low level output current ($V_{CC} = 1.65$ to 2.3 V) | +4 | mA |
| T_{op} | Operating temperature | -40 to 85 | °C |
| dt/dv | Input rise and fall time | 0 to 10 | ns/V |

3 Electrical characteristics

Table 6. DC specifications

| Symbol | Parameter | Test condition | | Value | | Unit |
|------------------|---------------------------------------|------------------------|---|----------------------|----------------------|------|
| | | V _{CC} (V) | | -40 to 85 °C | | |
| | | | | Min | Max | |
| V _{IH} | High level input voltage | 1.65 – 1.95 | | 0.65 V _{CC} | | V |
| | | 2.3 – 2.7 | | 0.7 V _{CC} | | |
| | | 3.0 – 5.5 | | 0.7 V _{CC} | | |
| V _{IL} | Low level input voltage | 1.65 – 1.95 | | | 0.35 V _{CC} | V |
| | | 2.3 – 2.7 | | | 0.3 V _{CC} | |
| | | 3.0 – 5.5 | | | 0.3 V _{CC} | |
| V _{OL} | Low level output voltage | 1.65 – 4.5 | I _O = 100 µA | | 0.1 | V |
| | | 1.65 | I _O = 4 mA | | 0.45 | |
| | | 2.3 | I _O = 8 mA | | 0.3 | |
| | | 3.0 | I _O = 16 mA | | 0.4 | |
| | | | I _O = 24 mA | | 0.55 | |
| 4.5 | I _O = 32 mA | | 0.55 | | | |
| I _{OZ} | High impedance output leakage current | 3.6 | V _I = 5.5 V | | ±10 | µA |
| I _I | Input leakage current | 1.65 – 5.5 | V _I = 0 – 5.5 V | | ±5 | µA |
| I _{off} | Power off leakage current | 0 | V _I or V _O = 5.5 V | | 10 | µA |
| I _{CC} | Quiescent supply current | 1.65 – 5.5 | V _I = V _{CC} or GND | | 10 | µA |
| | | 3.6 | V _I or V _O = 3.6 to 5.5 V | | ±10 | |

Table 7. AC electrical characteristics

| Symbol | Parameter | Test conditions | | | | Value | | Unit |
|------------------|------------------------|------------------------|------------------------|-----------------------|---|--------------|-----|------|
| | | V _{CC} (V) | C _L (pF) | R ₁ (Ω) | t _s = t _r (ns) | -40 to 85 °C | | |
| | | | | | | Min | Max | |
| t _{PLZ} | Propagation delay time | 1.65 – 1.95 | 30 | 1000 | 2.0 | 1.5 | 7.8 | ns |
| | | 2.3 – 2.7 | 30 | 500 | 2.0 | 1.0 | 4.3 | |
| | | 3.0 – 3.6 | 50 | 500 | 2.5 | 1.1 | 3.7 | |
| | | 4.5 – 5.5 | 50 | 500 | 2.5 | 1.0 | 2.9 | |
| t _{PZL} | Propagation delay time | 1.65 – 1.95 | 30 | 1000 | 2.0 | 1.5 | 7.8 | ns |
| | | 2.3 – 2.7 | 30 | 500 | 2.0 | 1.0 | 4.3 | |
| | | 3.0 – 3.6 | 50 | 500 | 2.5 | 1.1 | 3.7 | |
| | | 4.5 – 5.5 | 50 | 500 | 2.5 | 1.0 | 2.9 | |

Table 8. Capacitive characteristics

| Symbol | Parameter | Test conditions | | Value | | | Unit |
|------------------|--|------------------------|--|------------------------|-----|-----|------|
| | | V _{CC} (V) | | T _A = 25 °C | | | |
| | | | | Min | Typ | Max | |
| C _{IN} | Input capacitance | 3.3 | V _{IN} = 0 or V _{CC} | | 2.5 | | pF |
| C _{OUT} | Output capacitance | 3.3 | V _{IN} = 0 or V _{CC} | | 4 | | pF |
| C _{PD} | Power dissipation capacitance ⁽¹⁾ | 1.8 | f _{IN} = 10 MHz | | 8 | | pF |
| | | 2.5 | | | 8 | | |
| | | 3.3 | | | 8 | | |

1. C_{PD} is defined as the value of the IC's internal equivalent capacitance which is calculated from the operating current consumption without load. (Refer to test circuit). Average operating current can be obtained by the following equation: I_{CC(opr)} = C_{PD} × V_{CC} × f_{IN} + I_{CC}

Figure 3. Test circuit

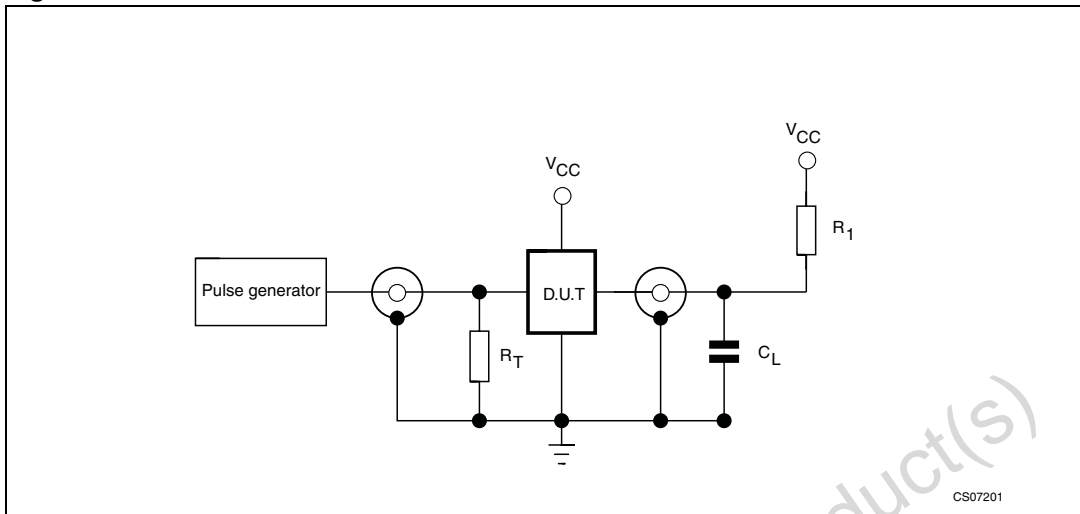
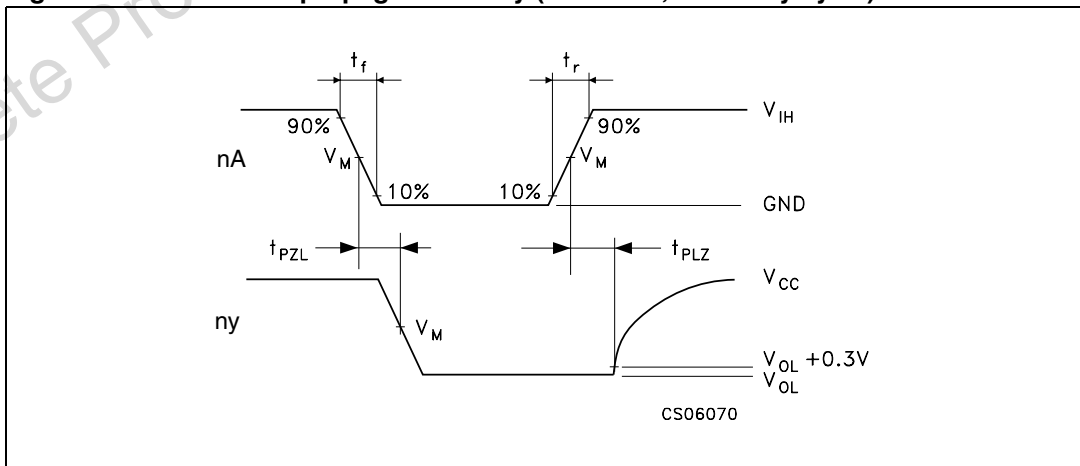

Table 9. Test circuit and waveform symbol value

| Symbol | V_{CC} | | |
|-------------|---------------|--------------|--------------|
| | 1.65 – 1.95 V | 2.3 – 2.7 V | 2.7 – 5.5 V |
| C_L | 30 pF | 30 pF/ 50 pF | 50 pF |
| R_1 | 1000 Ω | 500 Ω | 500 Ω |
| V_{IH} | V_{CC} | V_{CC} | V_{CC} |
| V_M | $V_{CC}/2$ | $V_{CC}/2$ | $V_{CC}/2$ |
| $t_r = t_f$ | < 2.0 ns | < 2.0 ns | < 2.5 ns |

Figure 4. Waveform: propagation delay (f = 1 MHz; 50% duty cycle)



4 Package mechanical data

In order to meet environmental requirements, ST offers these devices in different grades of ECOPACK® packages, depending on their level of environmental compliance. ECOPACK® specifications, grade definitions and product status are available at: www.st.com. ECOPACK® is an ST trademark.

Figure 5. Flip-chip 8 package outline

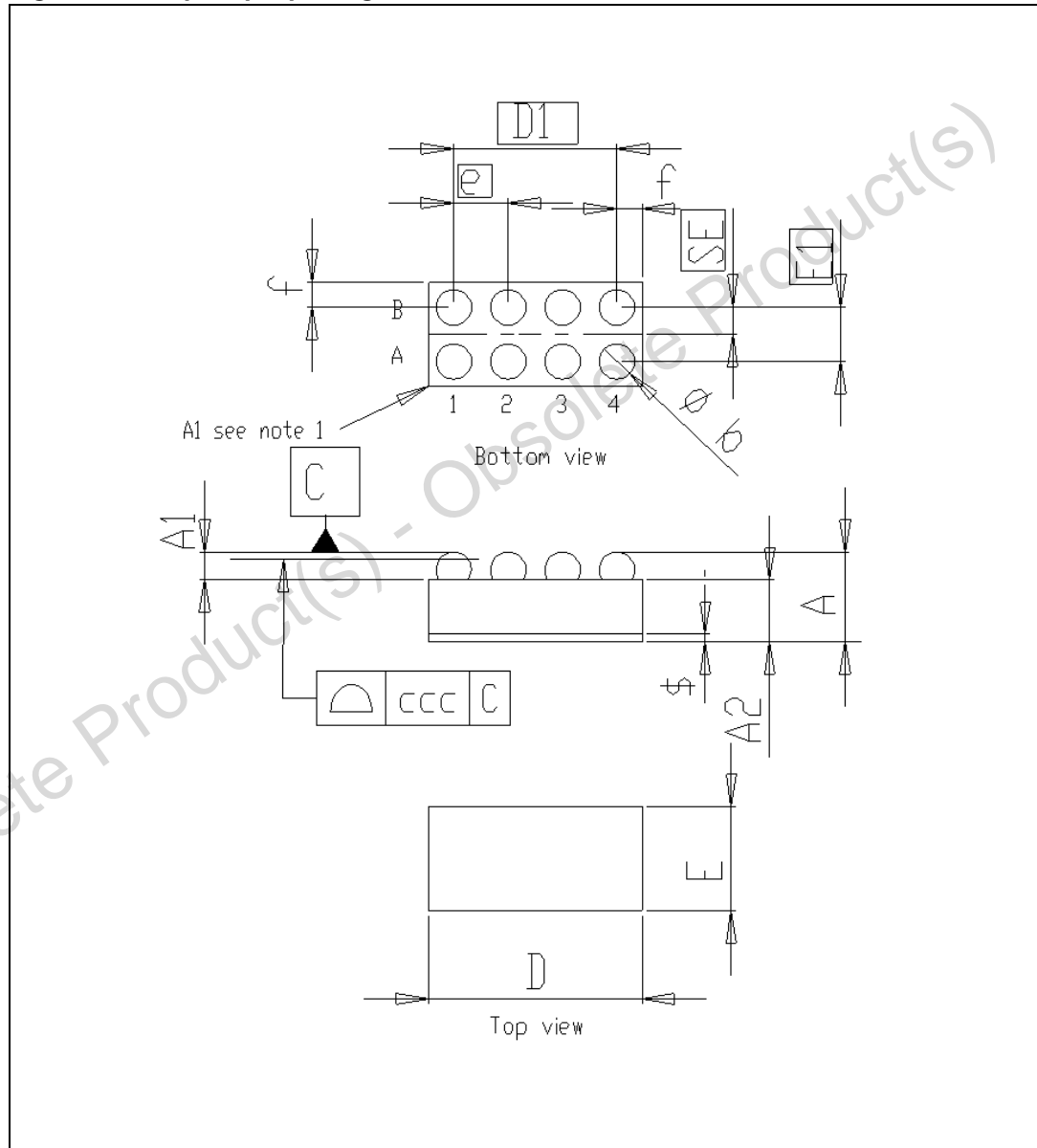

1. Drawing not to scale.

Table 10. Flip-chip 8 mechanical data

| Symbol | Millimeters | | |
|--------|-------------|-------|-------|
| | Min | Typ | Max |
| A | 0.535 | 0.58 | 0.625 |
| A1 | 0.18 | 0.205 | 0.23 |
| A2 | 0.355 | 0.375 | 0.395 |
| b | 0.215 | 0.255 | 0.295 |
| D | 1.85 | 1.9 | 1.95 |
| D1 | | 1.5 | |
| e | 0.45 | 0.5 | 0.55 |
| E | 0.85 | 0.9 | 0.95 |
| E1 | 0.45 | 0.5 | 0.55 |
| SE | | 0.25 | |
| f | 0.19 | 0.2 | 0.21 |
| ccc | | 0.08 | |

Figure 6. Flip-chip 8 footprint

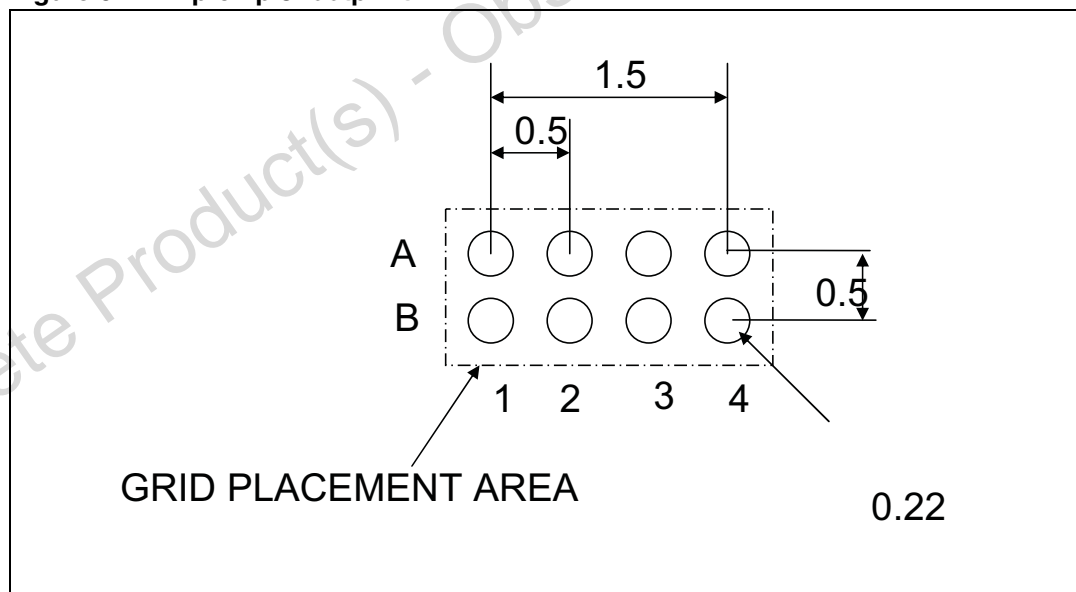

Figure 7. Flip-chip 8 tape and reel

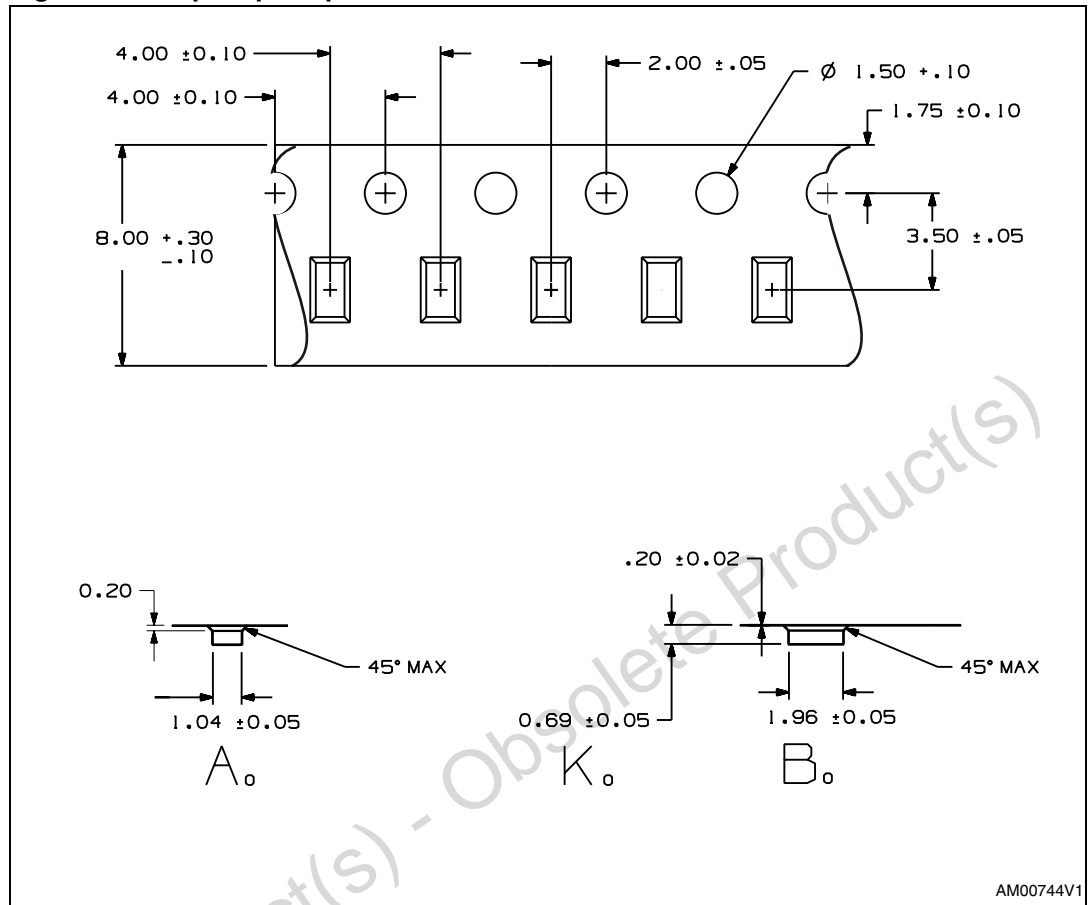

Figure 8. Tape orientation

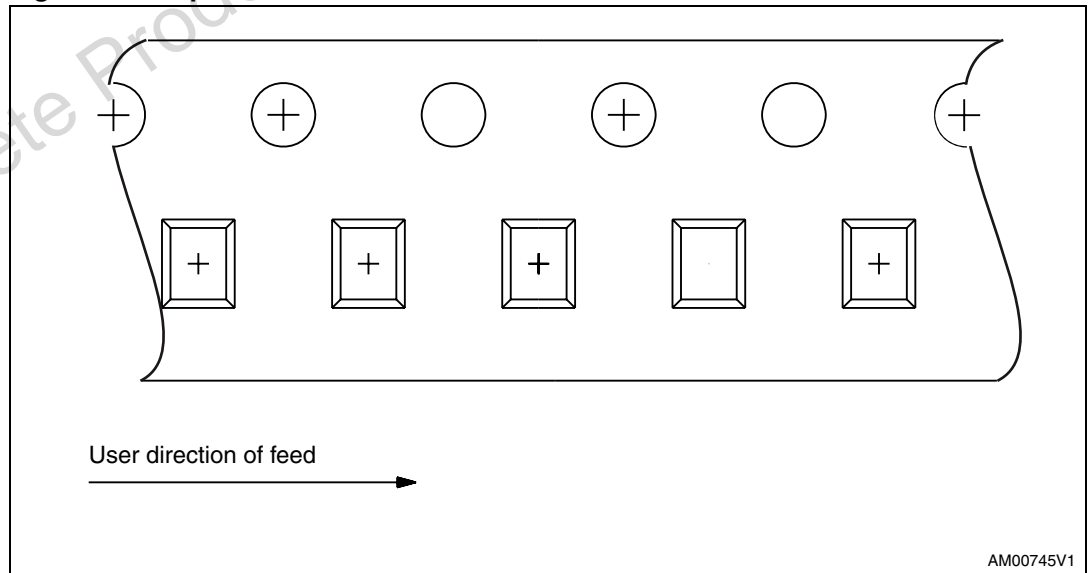
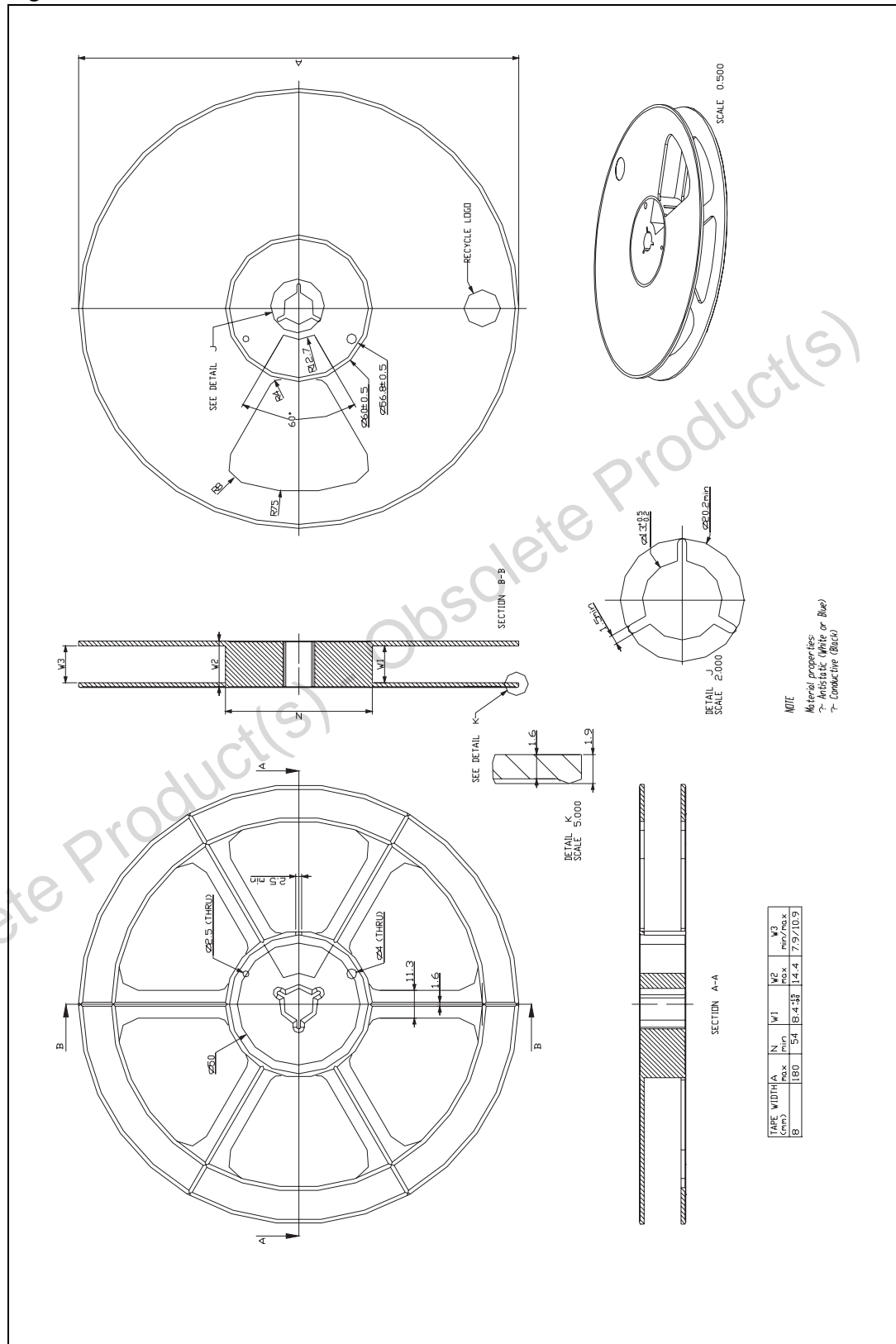

Figure 9. Reel information



5 Revision history

Table 11. Document revision history

| Date | Revision | Changes |
|-------------|----------|--|
| 10-Jul-2008 | 1 | Initial release. |
| 19-Mar-2009 | 2 | Preliminary status promoted to datasheet. Updated Section 4: Package mechanical data . |

Obsolete Product(s) - Obsolete Product(s)

Please Read Carefully:

Information in this document is provided solely in connection with ST products. STMicroelectronics NV and its subsidiaries ("ST") reserve the right to make changes, corrections, modifications or improvements, to this document, and the products and services described herein at any time, without notice.

All ST products are sold pursuant to ST's terms and conditions of sale.

Purchasers are solely responsible for the choice, selection and use of the ST products and services described herein, and ST assumes no liability whatsoever relating to the choice, selection or use of the ST products and services described herein.

No license, express or implied, by estoppel or otherwise, to any intellectual property rights is granted under this document. If any part of this document refers to any third party products or services it shall not be deemed a license grant by ST for the use of such third party products or services, or any intellectual property contained therein or considered as a warranty covering the use in any manner whatsoever of such third party products or services or any intellectual property contained therein.

UNLESS OTHERWISE SET FORTH IN ST'S TERMS AND CONDITIONS OF SALE ST DISCLAIMS ANY EXPRESS OR IMPLIED WARRANTY WITH RESPECT TO THE USE AND/OR SALE OF ST PRODUCTS INCLUDING WITHOUT LIMITATION IMPLIED WARRANTIES OF MERCHANTABILITY, FITNESS FOR A PARTICULAR PURPOSE (AND THEIR EQUIVALENTS UNDER THE LAWS OF ANY JURISDICTION), OR INFRINGEMENT OF ANY PATENT, COPYRIGHT OR OTHER INTELLECTUAL PROPERTY RIGHT.

UNLESS EXPRESSLY APPROVED IN WRITING BY AN AUTHORIZED ST REPRESENTATIVE, ST PRODUCTS ARE NOT RECOMMENDED, AUTHORIZED OR WARRANTED FOR USE IN MILITARY, AIR CRAFT, SPACE, LIFE SAVING, OR LIFE SUSTAINING APPLICATIONS, NOR IN PRODUCTS OR SYSTEMS WHERE FAILURE OR MALFUNCTION MAY RESULT IN PERSONAL INJURY, DEATH, OR SEVERE PROPERTY OR ENVIRONMENTAL DAMAGE. ST PRODUCTS WHICH ARE NOT SPECIFIED AS "AUTOMOTIVE GRADE" MAY ONLY BE USED IN AUTOMOTIVE APPLICATIONS AT USER'S OWN RISK.

Resale of ST products with provisions different from the statements and/or technical features set forth in this document shall immediately void any warranty granted by ST for the ST product or service described herein and shall not create or extend in any manner whatsoever, any liability of ST.

ST and the ST logo are trademarks or registered trademarks of ST in various countries.

Information in this document supersedes and replaces all information previously supplied.

The ST logo is a registered trademark of STMicroelectronics. All other names are the property of their respective owners.

© 2009 STMicroelectronics - All rights reserved

STMicroelectronics group of companies

Australia - Belgium - Brazil - Canada - China - Czech Republic - Finland - France - Germany - Hong Kong - India - Israel - Italy - Japan - Malaysia - Malta - Morocco - Singapore - Spain - Sweden - Switzerland - United Kingdom - United States of America

www.st.com