



STAP1011-180

RF power transistor the LdmoST family,
N-channel enhancement-mode lateral MOSFETs

Features

- Excellent thermal stability
- Common source configuration push-pull
- $P_{OUT} = 180W$ with 10 dB gain @ 1030 MHz
36 V/100 μ sec - 10%
- Plastic package
- In compliance with the 2002/95/EC european directive

Description

The STAP1011-180 is a common source N-channel enhancement-mode lateral field-effect RF power transistor. It is designed for 1030-1090 MHz avionics applications. STAP1011-180 is mounted in STAP ST advanced PowerSO-10RF package. The STAP package was designed to offer high reliability and power capability. It has been specially optimized for RF needs and offers excellent RF performances and ease of assembly.



Figure 1. Pin connection

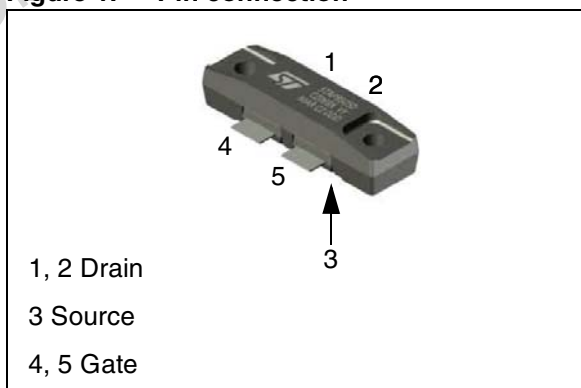

Table 1. Device summary

Order code	Package	Packaging
STAP1011-180	STAP2	Tube

1 Electrical data

1.1 Maximum ratings

$T_{CASE} = 25\text{ °C}$

Table 2. Absolute maximum ratings

Symbol	Parameter	Value	Unit
$V_{(BR)DSS}$	Drain-source voltage	65	V
V_{GS}	Gate-source voltage	± 20	V
P_{DISS}	Power dissipation (@ $T_c = 70\text{ °C}$)	800	W
T_J	Max. operating junction temperature	165	$^{\circ}\text{C}$
T_{STG}	Storage temperature	-65 to + 150	$^{\circ}\text{C}$

1.2 Thermal data

Table 3. Thermal data (CW)

Symbol	Parameter	Value	Unit
R_{thJC}	Junction - case thermal resistance	0.10	$^{\circ}\text{C/W}$

2 Electrical characteristics

$T_{CASE} = +25\text{ °C}$

2.1 Static

Table 4. Static (per side)

Symbol	Test conditions		Min	Typ	Max	Unit
$V_{(BR)DSS}$	$V_{GS} = 0\text{ V}$	$I_{DS} = 1\text{ mA}$	65			V
I_{DSS}	$V_{GS} = 0\text{ V}$	$V_{DS} = 28\text{ V}$			1	μA
I_{GSS}	$V_{GS} = 20\text{ V}$	$V_{DS} = 0\text{ V}$			1	μA
$V_{GS(Q)}$	$V_{DS} = 28\text{ V}$	$I_D = 100\text{ mA}$	2.0		4.0	V
$V_{DS(ON)}$	$V_{GS} = 10\text{ V}$	$I_D = 3\text{ A}$		0.7	0.9	V
G_{FS}	$V_{DS} = 10\text{ V}$	$I_D = 3\text{ A}$		3		S
$\Delta V_{TH}^{(1)}$	$I_D = 100\text{ mA}$				100	mV
C_{ISS}	$V_{GS} = 0\text{ V}$	$V_{DS} = 28\text{ V}$		83		pF
C_{OSS}	$V_{GS} = 0\text{ V}$	$V_{DS} = 28\text{ V}$		58		pF
C_{RSS}	$V_{GS} = 0\text{ V}$	$V_{DS} = 28\text{ V}$		3.0		pF

1. Absolute VGS difference between side 1 and side 2 of the device

2.2 Dynamic

Table 5. Dynamic

Symbol	Test conditions		Min	Typ	Max	Unit
P_{OUT}	$V_{DD} = 36\text{ V}$	$I_{DQ} = 300\text{ mA}$ $f = 1030\text{ MHz}$	180	195	-	W
G_{PS}	$V_{DD} = 36\text{ V}$	$I_{DQ} = 300\text{ mA}$ $P_{OUT} = 180\text{ W}$ $f = 1030\text{ MHz}$	10		-	dB
h_D	$V_{DD} = 36\text{ V}$	$I_{DQ} = 300\text{ mA}$ $P_{OUT} = 180\text{ W}$ $f = 1030\text{ MHz}$	45	50	-	%
Load mismatch	$V_{DD} = 36\text{ V}$	$I_{DQ} = 300\text{ mA}$ $P_{OUT} = 180\text{ W}$ $f = 1030\text{ MHz}$ All phase angles	10:1		-	VSWR
Rise time	$V_{DD} = 36\text{ V}$	$I_{DQ} = 300\text{ mA}$ $P_{OUT} = 180\text{ W}$ $f = 1030\text{ MHz}$		40	100	nsec
Fall time	$V_{DD} = 36\text{ V}$	$I_{DQ} = 300\text{ mA}$ $P_{OUT} = 180\text{ W}$ $f = 1030\text{ MHz}$		25	100	nsec
Power drop	$V_{DD} = 36\text{ V}$	$I_{DQ} = 300\text{ mA}$ $P_{OUT} = 180\text{ W}$ $f = 1030\text{ MHz}$		0.3	0.5	dB

3 Impedance

Figure 2. Current conventions

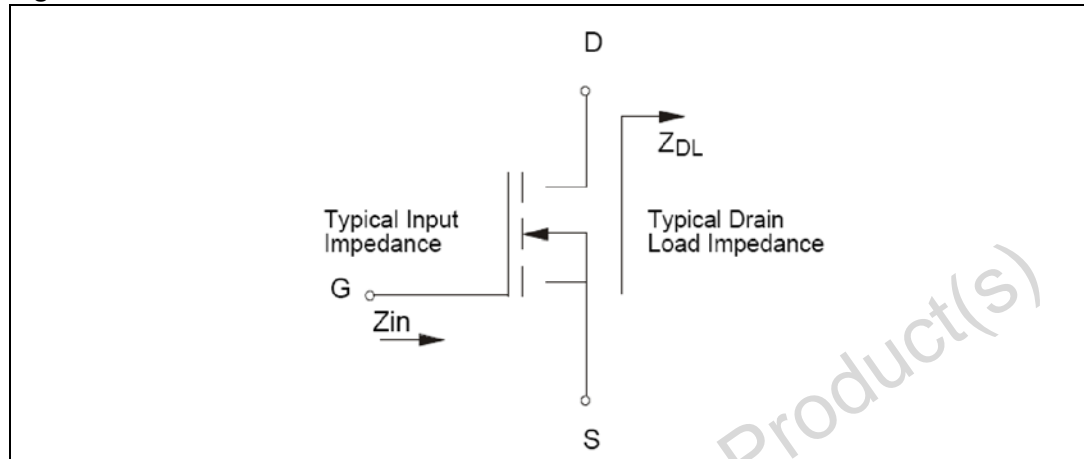

Table 6. Impedance data

Freq. (MHz)	Z _{IN} (Ω)	Z _{DL} (Ω)
1030 MHz	TBD	TBD

Note: Measured gate to gate and drain to drain respectively.

4 Typical performance

Figure 3. Output power & efficiency vs input power

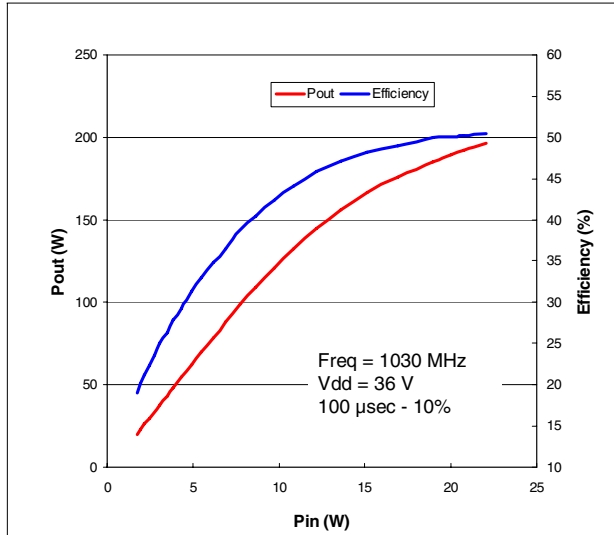

Figure 4. Gain vs output power & bias current

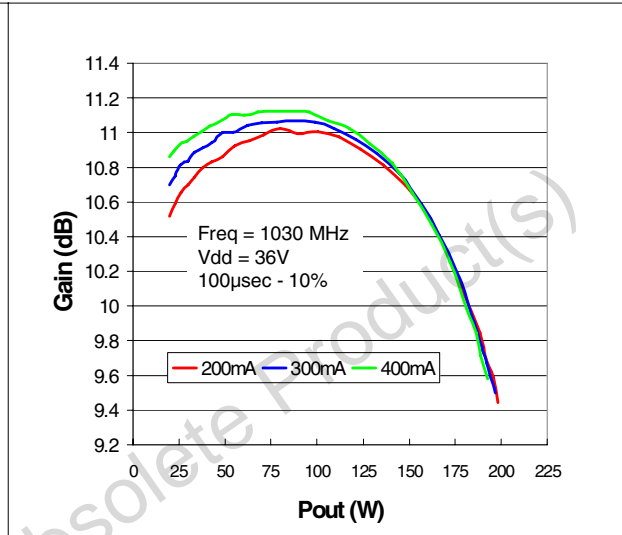
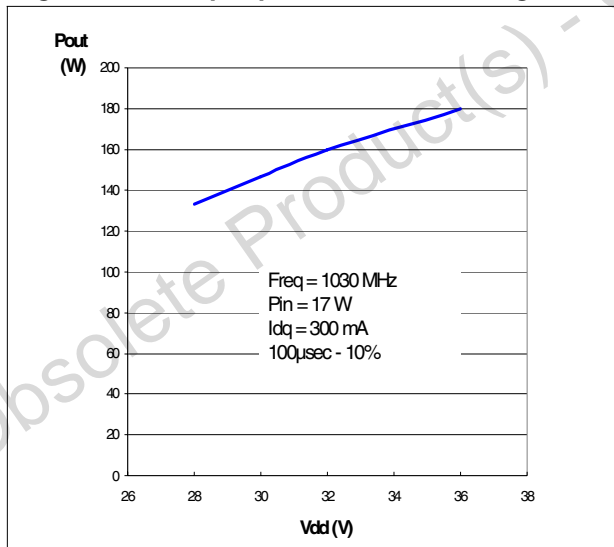

Figure 5. Output power vs drain voltage



5 Package mechanical data

In order to meet environmental requirements, ST offers these devices in different grades of ECOPACK® packages, depending on their level of environmental compliance. ECOPACK® specifications, grade definitions and product status are available at: www.st.com. ECOPACK® is an ST trademark.

Obsolete Product(s) - Obsolete Product(s)

Table 7. STAP2 mechanical data

Dim	mm			inch		
	Min	Typ	Max	Min	Typ	Max
A	5.40		5.65	0.212		0.222
A1	3.89		4.29	0.153		0.169
A2	4.70		4.90	0.185		0.193
B	9.27		9.53	0.365		0.375
B1	2.90		3.10	0.114		0.122
B2	15.10		15.65	0.594		0.616
C	6.60		6.99	0.260		0.275
D	32.74		33.05	1.289		1.301
D1	24.51		24.82	0.965		0.977
D2	17.15		17.45	0.675		0.687
E	7.42		7.57	0.292		0.298
E1	5.69		5.84	0.224		0.230
F	0.21		0.31	0.008		0.012
G	1.62		1.68	0.064		0.068
Q	3.15		3.30	0.124		0.130
R	0.64			0.025		

Figure 6. STAP2 mechanical data

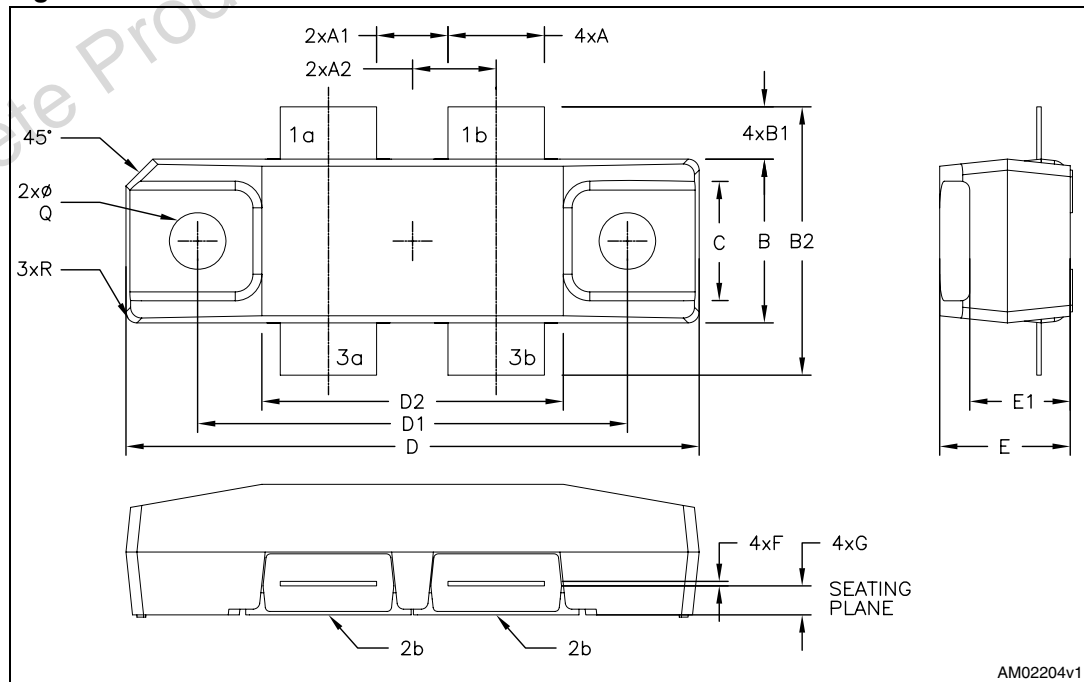

6 Revision history

Table 8. Document revision history

Date	Revision	Changes
07-May-2009	1	Initial release

Obsolete Product(s) - Obsolete Product(s)

Please Read Carefully:

Information in this document is provided solely in connection with ST products. STMicroelectronics NV and its subsidiaries ("ST") reserve the right to make changes, corrections, modifications or improvements, to this document, and the products and services described herein at any time, without notice.

All ST products are sold pursuant to ST's terms and conditions of sale.

Purchasers are solely responsible for the choice, selection and use of the ST products and services described herein, and ST assumes no liability whatsoever relating to the choice, selection or use of the ST products and services described herein.

No license, express or implied, by estoppel or otherwise, to any intellectual property rights is granted under this document. If any part of this document refers to any third party products or services it shall not be deemed a license grant by ST for the use of such third party products or services, or any intellectual property contained therein or considered as a warranty covering the use in any manner whatsoever of such third party products or services or any intellectual property contained therein.

UNLESS OTHERWISE SET FORTH IN ST'S TERMS AND CONDITIONS OF SALE ST DISCLAIMS ANY EXPRESS OR IMPLIED WARRANTY WITH RESPECT TO THE USE AND/OR SALE OF ST PRODUCTS INCLUDING WITHOUT LIMITATION IMPLIED WARRANTIES OF MERCHANTABILITY, FITNESS FOR A PARTICULAR PURPOSE (AND THEIR EQUIVALENTS UNDER THE LAWS OF ANY JURISDICTION), OR INFRINGEMENT OF ANY PATENT, COPYRIGHT OR OTHER INTELLECTUAL PROPERTY RIGHT.

UNLESS EXPRESSLY APPROVED IN WRITING BY AN AUTHORIZED ST REPRESENTATIVE, ST PRODUCTS ARE NOT RECOMMENDED, AUTHORIZED OR WARRANTED FOR USE IN MILITARY, AIR CRAFT, SPACE, LIFE SAVING, OR LIFE SUSTAINING APPLICATIONS, NOR IN PRODUCTS OR SYSTEMS WHERE FAILURE OR MALFUNCTION MAY RESULT IN PERSONAL INJURY, DEATH, OR SEVERE PROPERTY OR ENVIRONMENTAL DAMAGE. ST PRODUCTS WHICH ARE NOT SPECIFIED AS "AUTOMOTIVE GRADE" MAY ONLY BE USED IN AUTOMOTIVE APPLICATIONS AT USER'S OWN RISK.

Resale of ST products with provisions different from the statements and/or technical features set forth in this document shall immediately void any warranty granted by ST for the ST product or service described herein and shall not create or extend in any manner whatsoever, any liability of ST.

ST and the ST logo are trademarks or registered trademarks of ST in various countries.

Information in this document supersedes and replaces all information previously supplied.

The ST logo is a registered trademark of STMicroelectronics. All other names are the property of their respective owners.

© 2009 STMicroelectronics - All rights reserved

STMicroelectronics group of companies

Australia - Belgium - Brazil - Canada - China - Czech Republic - Finland - France - Germany - Hong Kong - India - Israel - Italy - Japan - Malaysia - Malta - Morocco - Philippines - Singapore - Spain - Sweden - Switzerland - United Kingdom - United States of America

www.st.com

