



# STH90N15F4-2 STP90N15F4

N-channel 150 V, 12.5 mΩ, 95 A TO-220, H<sup>2</sup>PAK  
STripFET™ DeepGATE™ Power MOSFET

Preliminary data

## Features

Type	V <sub>DSS</sub>	R <sub>DS(on)</sub> max	I <sub>D</sub>
STH90N15F4-2	150 V	< 15.6 mΩ	95 A
STP90N15F4	150 V	< 16 mΩ	90 A

- Extremely low on-resistance R<sub>DS(on)</sub>
- 100% avalanche tested

## Application

- Switching applications

## Description

This STripFET™ DeepGATE™ Power MOSFET technology is among the latest improvements, which have been especially tailored to minimize on-state resistance, with a new gate structure, providing superior switching performance.

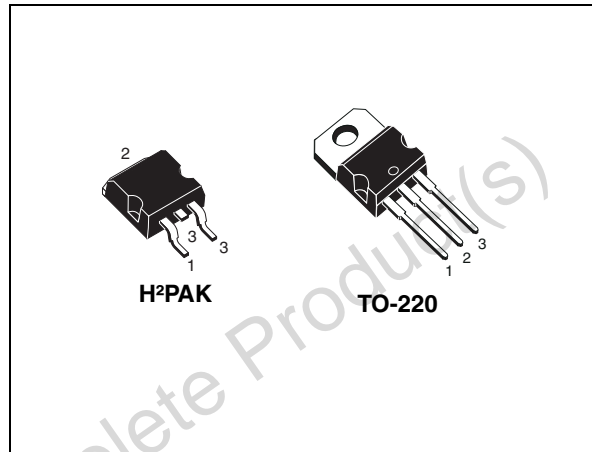
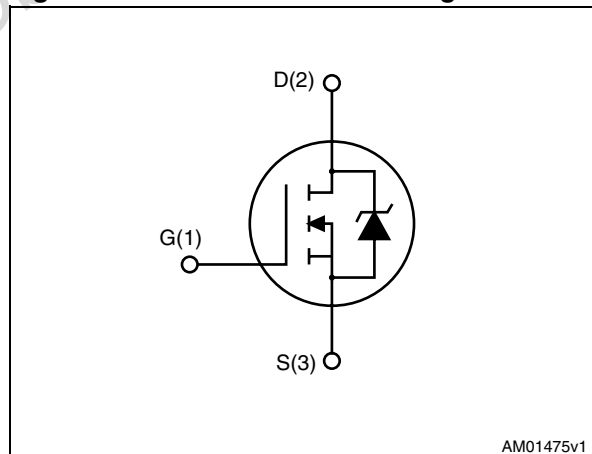

Figure 1. Internal schematic diagram



AM01475v1

Table 1. Device summary

Order codes	Marking	Package	Packaging
STH90N15F4-2	90N15F4	H <sup>2</sup> PAK	Tape and reel
STP90N15F4	90N15F4	TO-220	Tube

# Contents

1	Electrical ratings .....	3
2	Electrical characteristics .....	4
3	Test circuits .....	6
4	Package mechanical data .....	7
5	Revision history .....	11

Obsolete Product(s) - Obsolete Product(s)

# 1 Electrical ratings

**Table 2. Absolute maximum ratings**

Symbol	Parameter	Value		Unit
		TO-220	H <sup>2</sup> PAK	
V <sub>DS</sub>	Drain-source voltage (V <sub>GS</sub> = 0)	150		V
V <sub>GS</sub>	Gate-source voltage	± 20		V
I <sub>D</sub>	Drain current (continuous) at T <sub>C</sub> = 25 °C	90	95	A
I <sub>D</sub>	Drain current (continuous) at T <sub>C</sub> = 100 °C	65	66	A
I <sub>DM</sub> <sup>(1)</sup>	Drain current (pulsed)	360	380	A
P <sub>TOT</sub>	Total dissipation at T <sub>C</sub> = 25 °C	315		W
	Derating factor	2.1		W/°C
E <sub>AS</sub> <sup>(2)</sup>	Single pulse avalanche energy	TBD		mJ
T <sub>stg</sub>	Storage temperature	- 55 to 175		°C
T <sub>j</sub>	Max. operating junction temperature	- 55 to 175		°C

1. Pulse width limited by safe operating area

2. Starting T<sub>j</sub> = 25 °C, I<sub>D</sub> = 50 A, V<sub>DD</sub> = 60 V

**Table 3. Thermal data**

Symbol	Parameter	Value		Unit
		TO-220	H <sup>2</sup> PAK	
R <sub>thj-case</sub>	Thermal resistance junction-case max	0.48		°C/W
R <sub>thj-pcb</sub>	Thermal resistance junction-pcb max		35 <sup>(1)</sup>	°C/W
R <sub>thj-a</sub>	Thermal resistance junction-ambient max	62.5		°C/W
T <sub>l</sub>	Maximum lead temperature for soldering purpose	300		°C

1. When mounted on 1inch<sup>2</sup> FR-4 board, 2 oz Cu.

## 2 Electrical characteristics

( $T_{CASE} = 25\text{ °C}$  unless otherwise specified)

**Table 4. On/off states**

Symbol	Parameter	Test conditions	Min.	Typ.	Max.	Unit
$V_{(BR)DSS}$	Drain-source Breakdown voltage	$I_D = 250\ \mu\text{A}$ , $V_{GS} = 0$	150			V
$I_{DSS}$	Zero gate voltage Drain current ( $V_{GS} = 0$ )	$V_{DS} = \text{max rating}$			1	$\mu\text{A}$
		$V_{DS} = \text{max rating}$ , $T_C = 125\text{ °C}$			100	$\mu\text{A}$
$I_{GSS}$	Gate-body leakage current ( $V_{DS} = 0$ )	$V_{GS} = \pm 20\text{ V}$			100	nA
$V_{GS(th)}$	Gate threshold voltage	$V_{DS} = V_{GS}$ , $I_D = 250\ \mu\text{A}$	2		4	V
$R_{DS(on)}$	Static drain-source on resistance	$V_{GS} = 10\text{ V}$ , $I_D = 45\text{ A}$ <sup>(1)</sup>		13	16	m $\Omega$
		$V_{GS} = 10\text{ V}$ , $I_D = 45\text{ A}$ <sup>(2)</sup>		12.5	15.6	m $\Omega$

1. for TO-220

2. for H<sup>2</sup>PAK

**Table 5. Dynamic**

Symbol	Parameter	Test conditions	Min.	Typ.	Max.	Unit
$C_{iss}$	Input capacitance			10.4		nF
$C_{oss}$	Output capacitance	$V_{DS} = 25\text{ V}$ , $f = 1\text{ MHz}$ , $V_{GS} = 0$	-	750	-	pF
$C_{rss}$	Reverse transfer capacitance				288	
$Q_g$	Total gate charge	$V_{DD} = 80\text{ V}$ , $I_D = 90\text{ A}$ , $V_{GS} = 10\text{ V}$ <i>(see Figure 3)</i>	-	175	-	nC
$Q_{gs}$	Gate-source charge			TBD	-	nC
$Q_{gd}$	Gate-drain charge				TBD	nC

**Table 6. Switching times**

Symbol	Parameter	Test conditions	Min.	Typ.	Max.	Unit
$t_{d(on)}$ $t_r$	Turn-on delay time	$V_{DD} = 75\text{ V}$ , $I_D = 45\text{ A}$ $R_G = 4.7\ \Omega$ , $V_{GS} = 10\text{ V}$ <i>(see Figure 2)</i>	-	TBD	-	ns
	Rise time			TBD		ns
$t_{d(off)}$ $t_f$	Turn-off-delay time	$V_{DD} = 75\text{ V}$ , $I_D = 45\text{ A}$ , $R_G = 4.7\ \Omega$ , $V_{GS} = 10\text{ V}$ <i>(see Figure 2)</i>	-	TBD	-	ns
	Fall time			TBD		ns

**Table 7. Source drain diode**

Symbol	Parameter	Test conditions	Min.	Typ.	Max	Unit
$I_{SD}$	Source-drain current	TO-220	-		90	A
$I_{SDM}^{(1)}$	Source-drain current (pulsed)		-		360	A
$I_{SD}$	Source-drain current	H <sup>2</sup> PAK	-		95	A
$I_{SDM}^{(2)}$	Source-drain current (pulsed)		-		380	A
$V_{SD}^{(3)}$	Forward on voltage	$I_{SD} = 90\text{ A}, V_{GS} = 0$	-		TBD	V
$t_{rr}$	Reverse recovery time	$I_{SD} = 90\text{ A}, V_{DD} = 25\text{ V}$ $di/dt = 100\text{ A}/\mu\text{s}$ , $T_J = 150\text{ }^\circ\text{C}$ <i>(see Figure 4)</i>	-	TBD		ns
$Q_{rr}$	Reverse recovery charge			TBD		nC
$I_{RRM}$	Reverse recovery current			TBD		A

1. Pulse width limited by safe operating area.
2. Pulse width limited by safe operating area.
3. Pulsed: Pulse duration = 300  $\mu\text{s}$ , duty cycle 1.5%

Obsolete Product(s) - Obsolete Product(s)

### 3 Test circuits

**Figure 2. Switching times test circuit for resistive load**

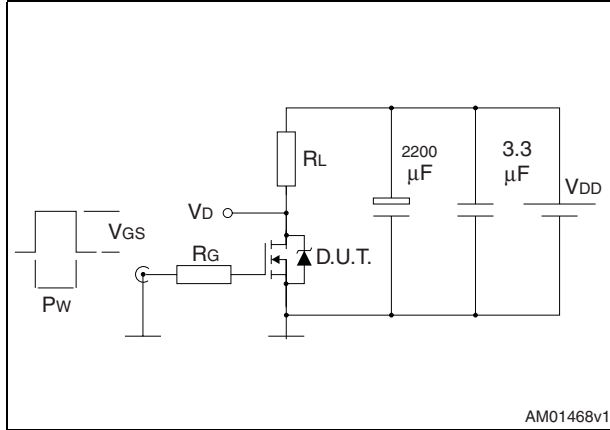

**Figure 3. Gate charge test circuit**

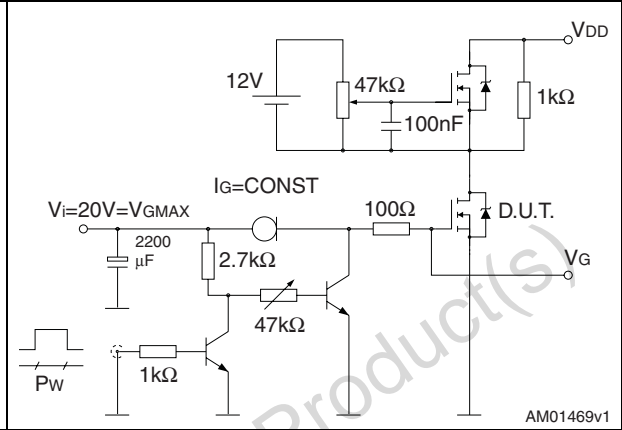

**Figure 4. Test circuit for inductive load switching and diode recovery times**

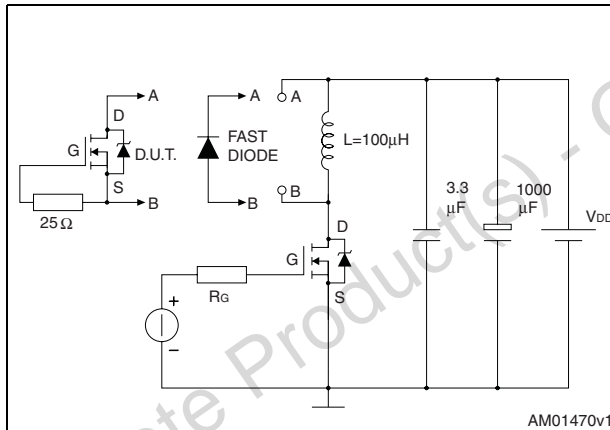

**Figure 5. Unclamped inductive load test circuit**

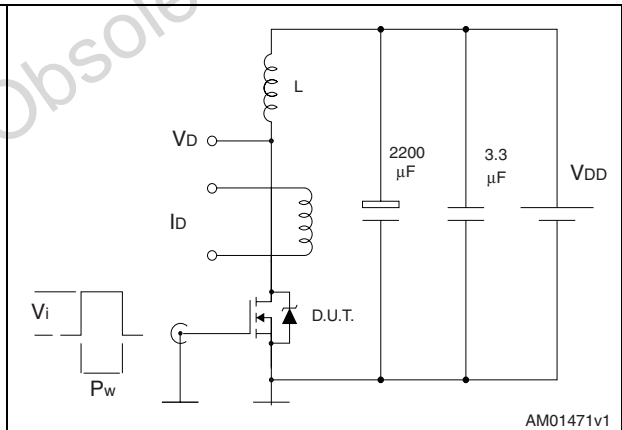

**Figure 6. Unclamped inductive waveform**

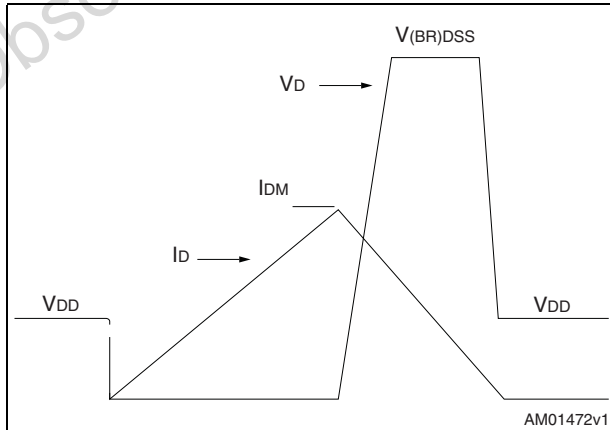

**Figure 7. Switching time waveform**

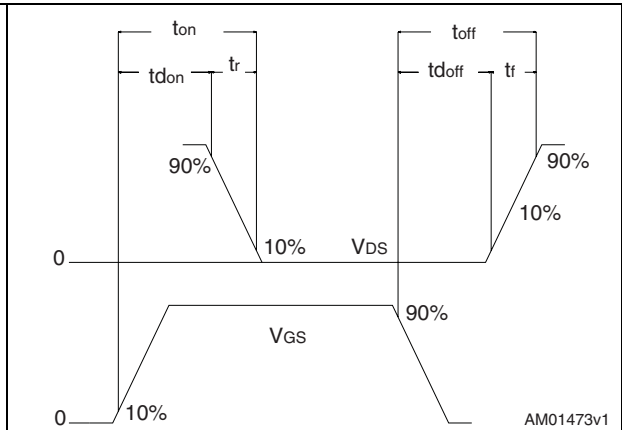

## 4 Package mechanical data

In order to meet environmental requirements, ST offers these devices in different grades of ECOPACK® packages, depending on their level of environmental compliance. ECOPACK® specifications, grade definitions and product status are available at: [www.st.com](http://www.st.com). ECOPACK is an ST trademark.

Obsolete Product(s) - Obsolete Product(s)

Table 8. H<sup>2</sup>PAK 2 leads mechanical data

Dim.	mm		
	Min.	Typ.	Max.
A	4.30		4.80
A1	0.03		0.20
C	1.17		1.37
e	4.98		5.18
E	0.50		0.90
F	0.78		0.85
H	10.00		10.40
H1	7.171		7.971
L	15.30		15.80
L1	1.27		1.40
L2	4.93		5.23
L3	7.45		7.85
L4	1.5		1.7
M	2.6		2.9
R	0.20		0.60
V	0°		8°

Figure 8. H<sup>2</sup>PAK 2 leads drawing

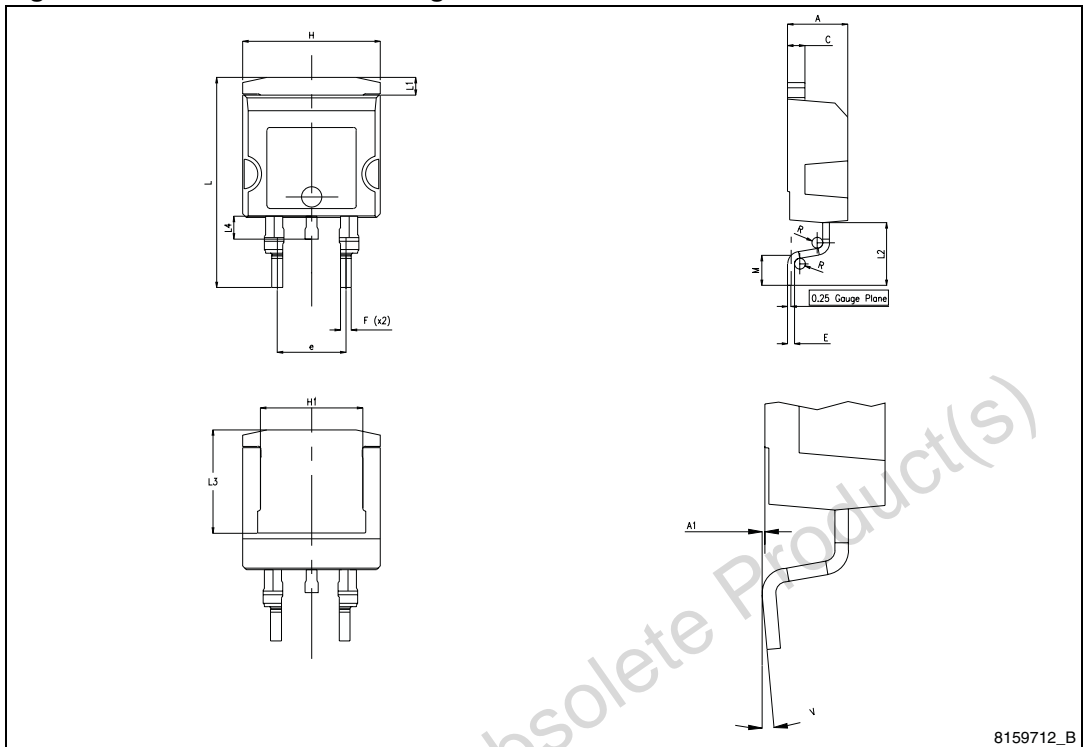

8159712\_B

Figure 9. H<sup>2</sup>PAK 2 recommended footprint

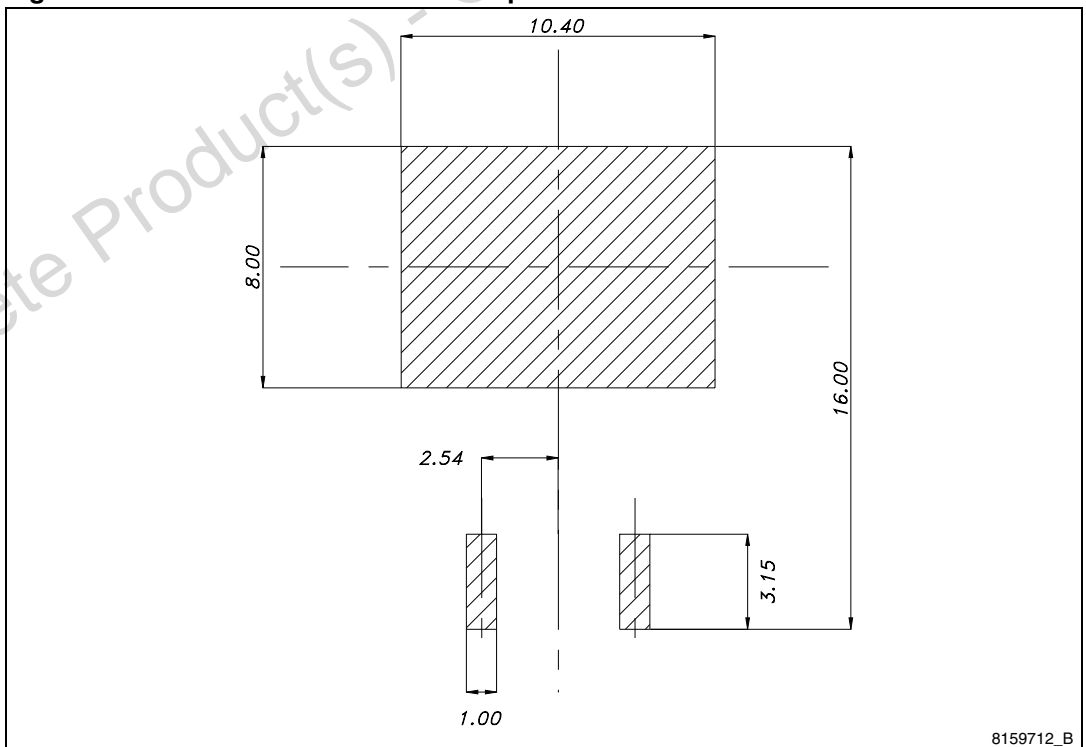

8159712\_B

TO-220 mechanical data

Dim	mm			inch		
	Min	Typ	Max	Min	Typ	Max
A	4.40		4.60	0.173		0.181
b	0.61		0.88	0.024		0.034
b1	1.14		1.70	0.044		0.066
c	0.48		0.70	0.019		0.027
D	15.25		15.75	0.6		0.62
D1		1.27			0.050	
E	10		10.40	0.393		0.409
e	2.40		2.70	0.094		0.106
e1	4.95		5.15	0.194		0.202
F	1.23		1.32	0.048		0.051
H1	6.20		6.60	0.244		0.256
J1	2.40		2.72	0.094		0.107
L	13		14	0.511		0.551
L1	3.50		3.93	0.137		0.154
L20		16.40			0.645	
L30		28.90			1.137	
∅P	3.75		3.85	0.147		0.151
Q	2.65		2.95	0.104		0.116

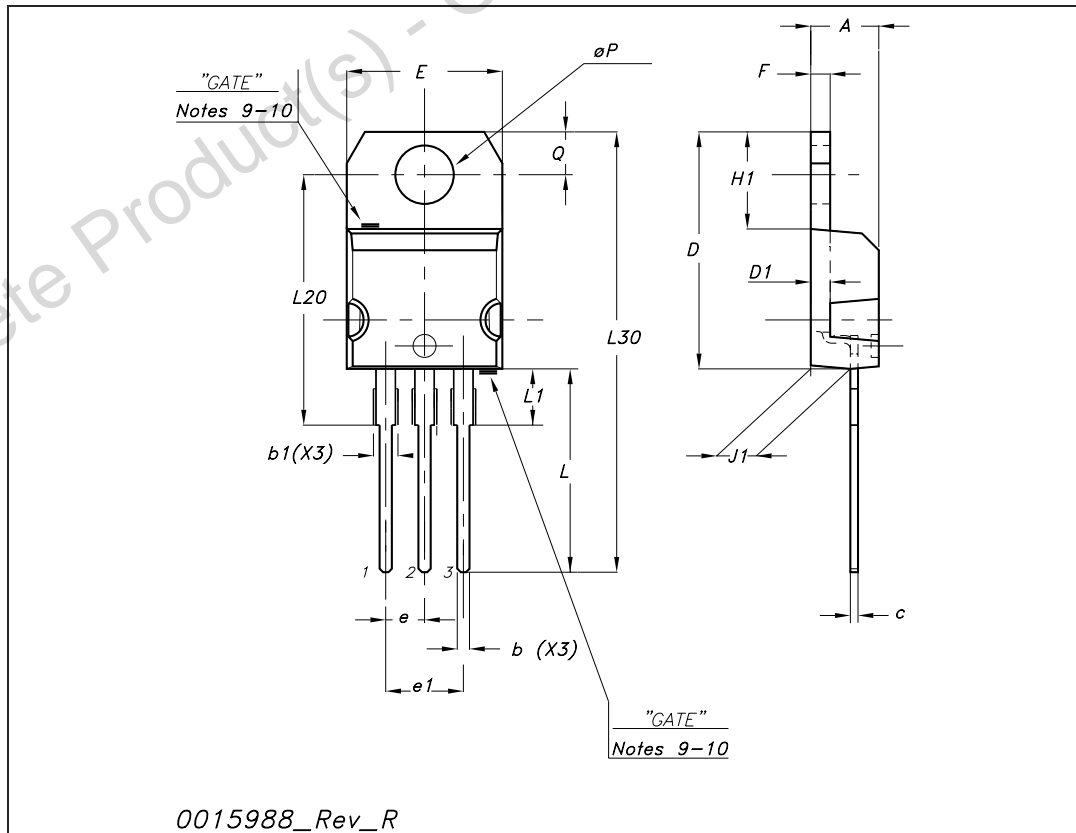

## 5 Revision history

**Table 9. Document revision history**

Date	Revision	Changes
15-Jun-2009	1	First release
15-Jul-2009	2	Document status promoted from target specification to preliminary data

Obsolete Product(s) - Obsolete Product(s)

**Please Read Carefully:**

Information in this document is provided solely in connection with ST products. STMicroelectronics NV and its subsidiaries ("ST") reserve the right to make changes, corrections, modifications or improvements, to this document, and the products and services described herein at any time, without notice.

All ST products are sold pursuant to ST's terms and conditions of sale.

Purchasers are solely responsible for the choice, selection and use of the ST products and services described herein, and ST assumes no liability whatsoever relating to the choice, selection or use of the ST products and services described herein.

No license, express or implied, by estoppel or otherwise, to any intellectual property rights is granted under this document. If any part of this document refers to any third party products or services it shall not be deemed a license grant by ST for the use of such third party products or services, or any intellectual property contained therein or considered as a warranty covering the use in any manner whatsoever of such third party products or services or any intellectual property contained therein.

**UNLESS OTHERWISE SET FORTH IN ST'S TERMS AND CONDITIONS OF SALE ST DISCLAIMS ANY EXPRESS OR IMPLIED WARRANTY WITH RESPECT TO THE USE AND/OR SALE OF ST PRODUCTS INCLUDING WITHOUT LIMITATION IMPLIED WARRANTIES OF MERCHANTABILITY, FITNESS FOR A PARTICULAR PURPOSE (AND THEIR EQUIVALENTS UNDER THE LAWS OF ANY JURISDICTION), OR INFRINGEMENT OF ANY PATENT, COPYRIGHT OR OTHER INTELLECTUAL PROPERTY RIGHT.**

**UNLESS EXPRESSLY APPROVED IN WRITING BY AN AUTHORIZED ST REPRESENTATIVE, ST PRODUCTS ARE NOT RECOMMENDED, AUTHORIZED OR WARRANTED FOR USE IN MILITARY, AIR CRAFT, SPACE, LIFE SAVING, OR LIFE SUSTAINING APPLICATIONS, NOR IN PRODUCTS OR SYSTEMS WHERE FAILURE OR MALFUNCTION MAY RESULT IN PERSONAL INJURY, DEATH, OR SEVERE PROPERTY OR ENVIRONMENTAL DAMAGE. ST PRODUCTS WHICH ARE NOT SPECIFIED AS "AUTOMOTIVE GRADE" MAY ONLY BE USED IN AUTOMOTIVE APPLICATIONS AT USER'S OWN RISK.**

Resale of ST products with provisions different from the statements and/or technical features set forth in this document shall immediately void any warranty granted by ST for the ST product or service described herein and shall not create or extend in any manner whatsoever, any liability of ST.

ST and the ST logo are trademarks or registered trademarks of ST in various countries.

Information in this document supersedes and replaces all information previously supplied.

The ST logo is a registered trademark of STMicroelectronics. All other names are the property of their respective owners.

© 2009 STMicroelectronics - All rights reserved

STMicroelectronics group of companies

Australia - Belgium - Brazil - Canada - China - Czech Republic - Finland - France - Germany - Hong Kong - India - Israel - Italy - Japan - Malaysia - Malta - Morocco - Philippines - Singapore - Spain - Sweden - Switzerland - United Kingdom - United States of America

[www.st.com](http://www.st.com)