

How to calibrate an STM32L1xx internal RC oscillator

Introduction

The STM32L1xx microcontrollers have two internal RC oscillators that can be selected as the system clock source. These are known as the HSI (High-Speed Internal) and MSI (Multi-Speed Internal) oscillators. The HSI oscillator has a typical frequency of 16 MHz. The MSI oscillator is a lower speed, low-power clock source.

The operating temperature has an impact on the accuracy of the RC oscillators. At 25 °C, the HSI and MSI oscillators have an accuracy of $\pm 1\%$ typically, but in the temperature range of -40 to 105 °C, the accuracy decreases.

To compensate for the influence of temperature on internal RC oscillators accuracy, the STM32L1xx microcontrollers have built-in features to allow you to calibrate the HSI and MSI oscillators and measure the MSI and LSI (Low-Speed Internal) oscillator frequencies.

This application note focuses on how to calibrate internal RC oscillators: HSI and MSI. Two methods are presented: the first method is based on finding the frequency with the minimum error and the second one consists in finding the maximum allowed frequency error. Both are implemented by providing an accurate reference signal.

The measurement of the MSI and LSI oscillators is performed by connecting the oscillator to a timer input capture.

- Note:*
- 1 *STM32L1xx refers to Ultra Low Power High-density, Medium-density Plus and Medium-density devices in this document.*
 - 2 *Ultra Low Power Medium-density devices are STM32L151xx and STM32L152xx microcontrollers where the Flash memory density ranges between 64 and 128 Kbytes.*
 - 3 *Ultra Low Power Medium-density Plus devices are STM32L151xx, STM32L152xx and STM32L162xx microcontrollers where the Flash memory density is 256 Kbytes.*
 - 4 *Ultra Low Power High-density devices are STM32L151xx, STM32L152xx and STM32L162xx microcontrollers where the Flash memory density is 384 Kbytes.*

Contents

- 1 STM32L1xx system clock 4**

- 2 Internal RC oscillator calibration 6**
 - 2.1 Calibration principle 8
 - 2.2 Hardware implementation 9
 - 2.2.1 Case where LSE is used as the reference frequency 9
 - 2.2.2 Case where another source is used as the reference frequency 10
 - 2.3 Description of the internal oscillator calibration firmware 11
 - 2.3.1 Internal oscillator calibration with minimum error 11
 - 2.3.2 HSI calibration with fixed error 13
 - 2.3.3 MSI calibration with fixed error 15
 - 2.3.4 Internal oscillator frequency measurement 17
 - 2.4 Recommendations on the use of the calibration library 19
 - 2.5 Calibration process performance 19
 - 2.5.1 Duration of the calibration process 19

- 3 Internal oscillator measurement 21**
 - 3.1 Measurement principle 21
 - 3.2 Description of the internal oscillator measurement firmware 23
 - 3.3 Internal oscillator calibration/measurement demo description 23

- 4 Conclusion 26**

- 5 Revision history 27**

List of figures

Figure 1.	Simplified clock tree	4
Figure 2.	HSI oscillator trimming characteristics	6
Figure 3.	MSI trimming behavior	8
Figure 4.	Timing diagram of internal oscillator calibration	9
Figure 5.	Hardware connection using LSE as the reference frequency.	10
Figure 6.	Hardware connection using external reference frequency	10
Figure 7.	Internal oscillator calibration: finding the minimum frequency error	12
Figure 8.	“Spring loop”	13
Figure 9.	HSI calibration flowchart: maximum allowed frequency error.	14
Figure 10.	MSI calibration flowchart: maximum allowed frequency error.	16
Figure 11.	Internal oscillator frequency measurement flowchart	18
Figure 12.	MSI measurement configuration.	21
Figure 13.	LSI measurement configuration	22
Figure 14.	Timing diagram of an internal RC oscillator measurement	22
Figure 15.	HSI calibration	24
Figure 16.	MSI calibration	25

1 STM32L1xx system clock

The STM32L1xx microcontroller family has various clock sources that can be used to drive the system clock:

- 16 MHz High-Speed Internal (HSI) RC oscillator clock
- 1 to 24 MHz High-Speed External (HSE) oscillator clock
- 65.5 kHz to 4.2 MHz Multi-Speed Internal (MSI) RC oscillator clock
- 2 to 24 MHz Phase-Locked Loop (PLL) that is clocked by HSI or HSE oscillators

The High-Speed Internal (HSI) RC oscillator typically has a frequency of 16 MHz and consumes 100 µA.

The Multi-Speed Internal (MSI) RC oscillator provides seven frequency ranges: 65.5 kHz, 131 kHz, 262 kHz, 524 kHz, 1.05 MHz, 2.1 MHz (default value) and 4.2 MHz. It is designed to operate with a current proportional to the frequency (refer to the product datasheet for more details about MSI power consumption versus selected range), so as to minimize the internal oscillator consumption when the CPU runs at low frequencies. The MSI clock is used as a system clock after restart from Reset, Wake-up from stop, and Standby low power modes.

The internal RC oscillators (HSI and MSI) have the advantage of providing a low-cost clock source (no external components required). It also has a faster startup time and lower power consumption than the external oscillator. HSI and MSI oscillators can be calibrated to improve their accuracy. But even with calibration, the internal RC oscillator frequency is less accurate than the frequency of an external crystal oscillator or ceramic resonator (tens of ppm).

Note: The internal RC oscillators (HSI and MSI) can also be used as a backup clock source (auxiliary clock) if the external oscillator fails.

Figure 1. Simplified clock tree

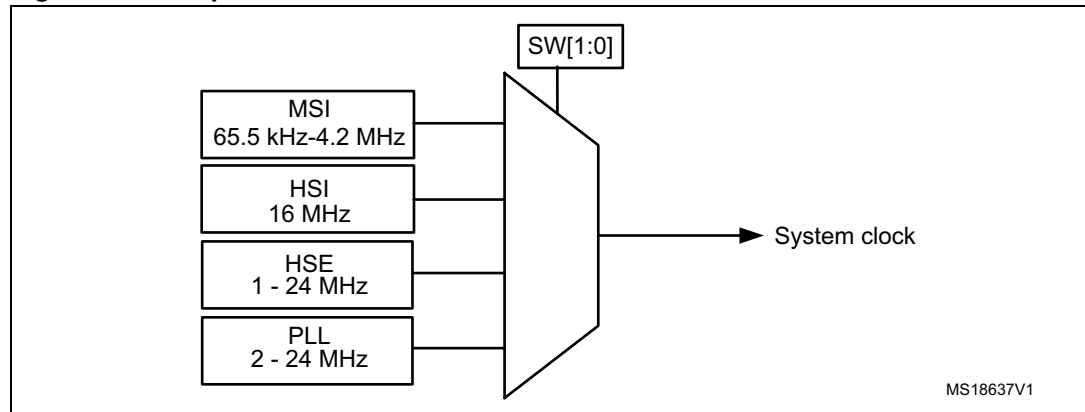

The STM32L1x devices also have two secondary clock sources (that cannot be used as system clock sources):

- 37 kHz Low-Speed Internal (LSI) RC which is designed to drive the independent watchdog and optionally the Real Time Clock (RTC). The LSI oscillator cannot be calibrated, but can be measured to evaluate frequency deviations (due to temperature and voltage changes)
- 32.768 kHz Low-Speed External crystal (LSE crystal) which optionally drives the Real Time Clock (RTC)

2 Internal RC oscillator calibration

The frequency of the internal RC oscillators may vary from one chip to another due to manufacturing process variations. For this reason, MSI and HSI RC oscillators are factory-calibrated by ST to have a 1% accuracy at $T_A = 25\text{ }^\circ\text{C}$. After reset, the factory calibration value is automatically loaded in the internal calibration bits.

The frequency of the internal RC oscillators can be fine-tuned to achieve better accuracy with wider temperature and supply voltage ranges. The trimming bits are used for this purpose.

For the HSI oscillator, the calibration value is loaded in HSICAL[7:0] bits after reset. Five trimming bits HSITRIM[4:0] are used for fine-tuning. The default trimming value is 16. An increase/decrease in this trimming value causes an increase/decrease in HSI frequency. The HSI oscillator is fine-tuned in steps of 0.5% (around 80 kHz).

- Writing a trimming value in the range of 17 to 31 increases the HSI frequency.
- Writing a trimming value in the range of 0 to 15 decreases the HSI frequency.
- Writing a trimming value equal to 16 causes the HSI frequency to keep its default value.

The graph below shows HSI oscillator behavior versus calibration value. The HSI oscillator frequency increases with calibration value (calibration value = default HSICAL[7:0] + HSITRIM[4:0]), except at modulo 16. At these calibration values, the negative steps can reach three times the positive steps.

Figure 2. HSI oscillator trimming characteristics

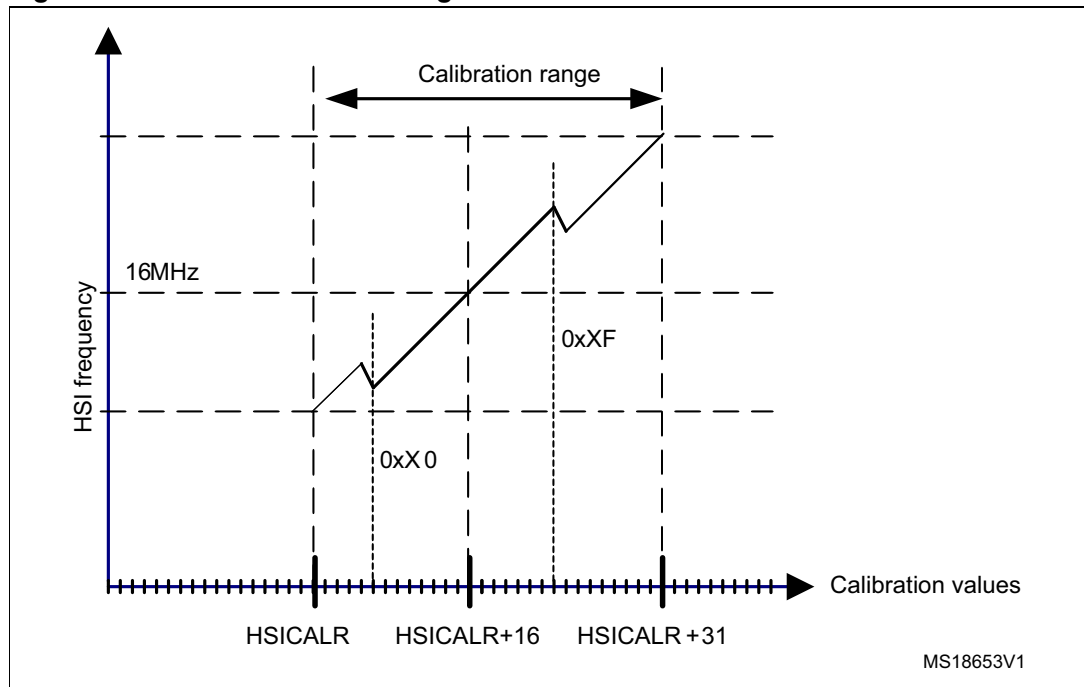

MS18653V1

- For the MSI oscillator, the calibration value is loaded in the MSICAL[7:0] bits after reset. Eight trimming bits MSITRIM[7:0] are used giving a wide tuning range. The calibration is based on adding the default MSICAL[7:0] bits (reset value) to the MSITRIM[7:0] bits. The result is stored in MSICAL[7:0]:

$$\text{MSICAL}[7:0] = \text{default MSICAL}[7:0] + \text{MSITRIM}[7:0]$$

Example:

Assuming the default MSI calibration value MSICAL[7:0] is 0x80.

1. Writing a value between 0x01 and 0x7F in MSITRIM[7:0] leads to calibration value MSICAL[7:0] in the range of:

$$\text{MSICAL}[7:0] = 0x80 + 0x01 = 0x81$$

$$\text{and MSICAL}[7:0] = 0x80 + 0x7F = 0xFF$$

These results are greater than 0x80 (default MSICAL[7:0] value) and consequently the MSI frequency is increased by 1 step (0x81 - 0x80) to 127 steps (0xFF - 0x80).

2. Writing a value between 0x81 and 0xFF in MSITRIM[7:0] leads to calibration value MSICAL[7:0] in the range of:

$$\text{MSICAL}[7:0] = 0x80 + 0x81 = 0x01$$

$$\text{and MSICAL}[7:0] = 0x80 + 0xFF = 0x7F$$

These results are lower than 0x80 (default MSICAL[7:0] value) and consequently the MSI frequency is decreased by 1 step (0x01) to 127 steps (0x7F).

3. Writing the default calibration value (0x80) in MSITRIM[7:0] leads to calibration value MSICAL[7:0] equal to $\text{MSICAL}[7:0] = 0x80 + 0x80 = 0x00$ and consequently the MSI frequency is decreased by 128 steps (minimum frequency).

Figure 3 below shows MSI behavior at range 6 (4194304 Hz) versus MSICAL[7:0].

Figure 3. MSI trimming behavior

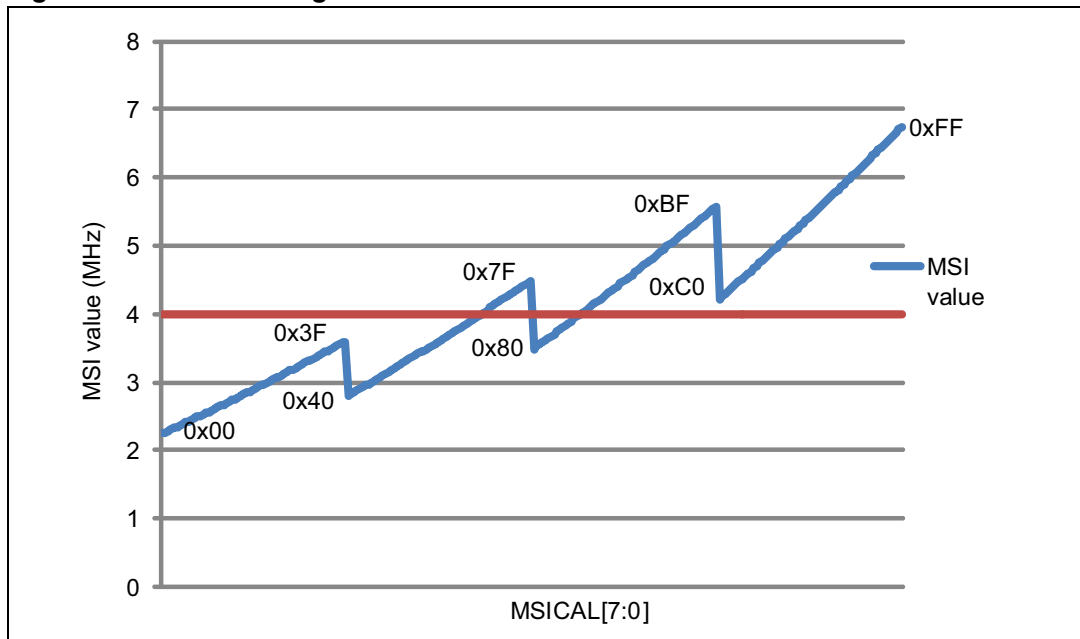

Note the negative steps when the two MSB bits change from “00” to “01”, from “01” to “10” and from “10” to “11”. The change of the six LSBs leads to fine-tuning of around 0.5% per step.

2.1 Calibration principle

The calibration principle consists in:

1. Setting the internal RC oscillator (that needs to be calibrated) as system clock,
2. Measuring the internal RC oscillator (HSI or MSI) frequency for each trimming value,
3. Computing the frequency error for each trimming value,
4. Finally, setting the trimming bits with the optimum value (corresponding to the lowest frequency error).

The internal oscillator frequency is not measured directly but is computed from the number of clock pulses counted using a timer compared with the typical value. To do this, a very accurate reference frequency must be available such as the LSE frequency provided by the external 32.768 kHz crystal or the 50 Hz/60 Hz of the mains (refer to [Section 2.2.2: Case where another source is used as the reference frequency](#)).

The following figure shows how the reference signal period is measured in number of timer counts.

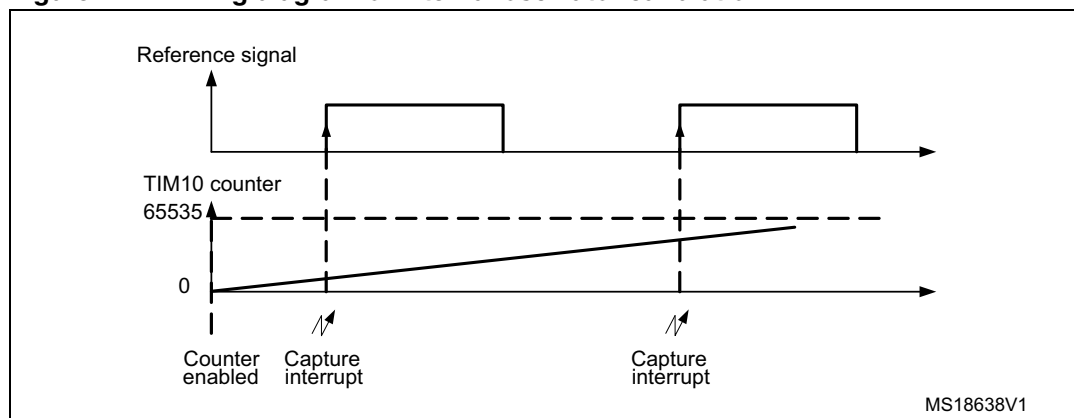
Figure 4. Timing diagram of internal oscillator calibration

After enabling the timer counter, when the first rising edge of the reference signal occurs, the timer counter value is captured and stored in `IC1ReadValue1`. At the second rising edge, the timer counter is captured again and stored in `IC1ReadValue2`. The elapsed time between two consecutive rising edges ($IC1ReadValue2 - IC1ReadValue1$) represents an entire period of the reference signal.

Since the timer counter is clocked by the system clock (internal RC oscillator HSI or MSI), the real frequency generated by the internal RC oscillator versus the reference signal is given by:

$$\text{Measuredfrequency} = (IC1ReadValue2 - IC1ReadValue1) \times \text{referencefrequency}$$

The error (in Hz) is computed as the absolute value of the difference between the measured frequency and the typical value.

Hence the internal oscillator frequency error is expressed as:

$$\text{Error(Hz)} = |\text{Measuredfrequency} - \text{typicalvalue}|$$

After calculating the error for each trimming value, the algorithm determines the optimum trimming value (that corresponds to the nearest frequency to typical value) to be programmed in the trimming bits (refer to [Section 2.3: Description of the internal oscillator calibration firmware](#) for more details).

2.2 Hardware implementation

2.2.1 Case where LSE is used as the reference frequency

The STM32L1xx offers a useful feature, that is the ability to connect internally the Low-Speed External (LSE) oscillator to Timer 10 channel 1. Thus, the LSE clock can be used as the reference signal for internal oscillator calibration and no additional hardware connections are required. Only the LSE oscillator should be connected to `OSC32_IN` and `OSC32_OUT`.

[Figure 5](#) shows the hardware connections needed for internal oscillators calibration using LSE as an accurate frequency source for calibration.

Figure 5. Hardware connection using LSE as the reference frequency

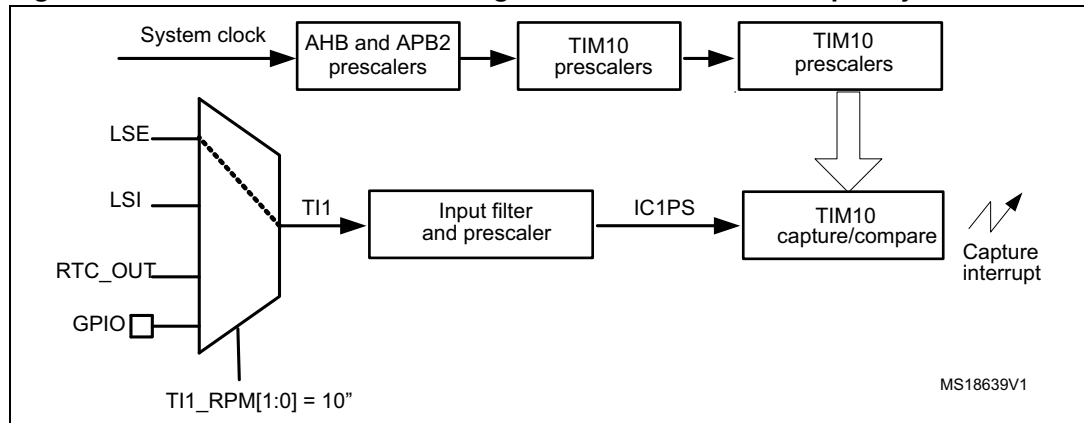

In the above figure:
 TI1_RPM: TIM10 input 1 remapping
 TI1_RPM: Timer input 1
 IC1PS: Input capture 1 prescaled

2.2.2 Case where another source is used as the reference frequency

Any signal with accurate frequency can be used for internal oscillator calibration, and the mains is one of the possibilities.

As shown by *Figure 6* below, the reference signal should be connected to Timer 10 channel 1.

Figure 6. Hardware connection using external reference frequency

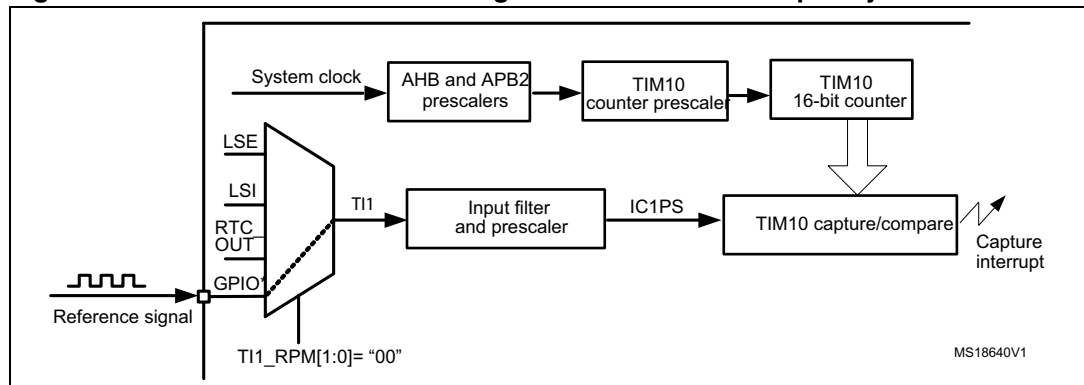

In the above figure:
 TI1_RPM: TIM10 input 1 remapping
 TI1: Timer input 1
 IC1PS: Input capture 1 prescaled
 *PA6, PB8, PB12 or PE0 can be used as TIM10 channel 1

Note: When using an external signal as a reference, timers TIM2, TIM3, TIM4, TIM9 or TIM11 can be used instead of TIM10. The firmware provided with this application note uses TIM10. Refer to application note AN2868 “Internal RC oscillator (HSI) calibration” for more details about using mains frequency for calibration.

2.3 Description of the internal oscillator calibration firmware

The internal RC oscillator calibration firmware provided with this application note includes three major functions:

- `uint32_t InternOsc_CalibrateMinError(void)`
- `uint32_t HSI_CalibrateFixedError(void)`
- `uint32_t MSI_CalibrateFixedError(void)`

2.3.1 Internal oscillator calibration with minimum error

The `InternOsc_CalibrateMinError()` function calibrates the internal oscillator to have the frequency nearest to the typical value. It measures all frequencies for different trimming values and provides the trimming value that corresponds to the frequency with the minimum error. The trimming value thus obtained is programmed in the trimming bits.

After calibration, the `InternOsc_CalibrateMinError()` function returns the internal oscillator frequency value as an unsigned 32-bit integer (`uint32_t`).

The flowchart in [Figure 7](#) provides the algorithm for this function.

Example

```
uint32_t InternOscAfterCalib = 0;
{
.....
/* Get the internal oscillator (HSI/MSI) value after calibration */
InternOscAfterCalib = InternOsc_CalibrateMinError();
}
```

Figure 7. Internal oscillator calibration: finding the minimum frequency error

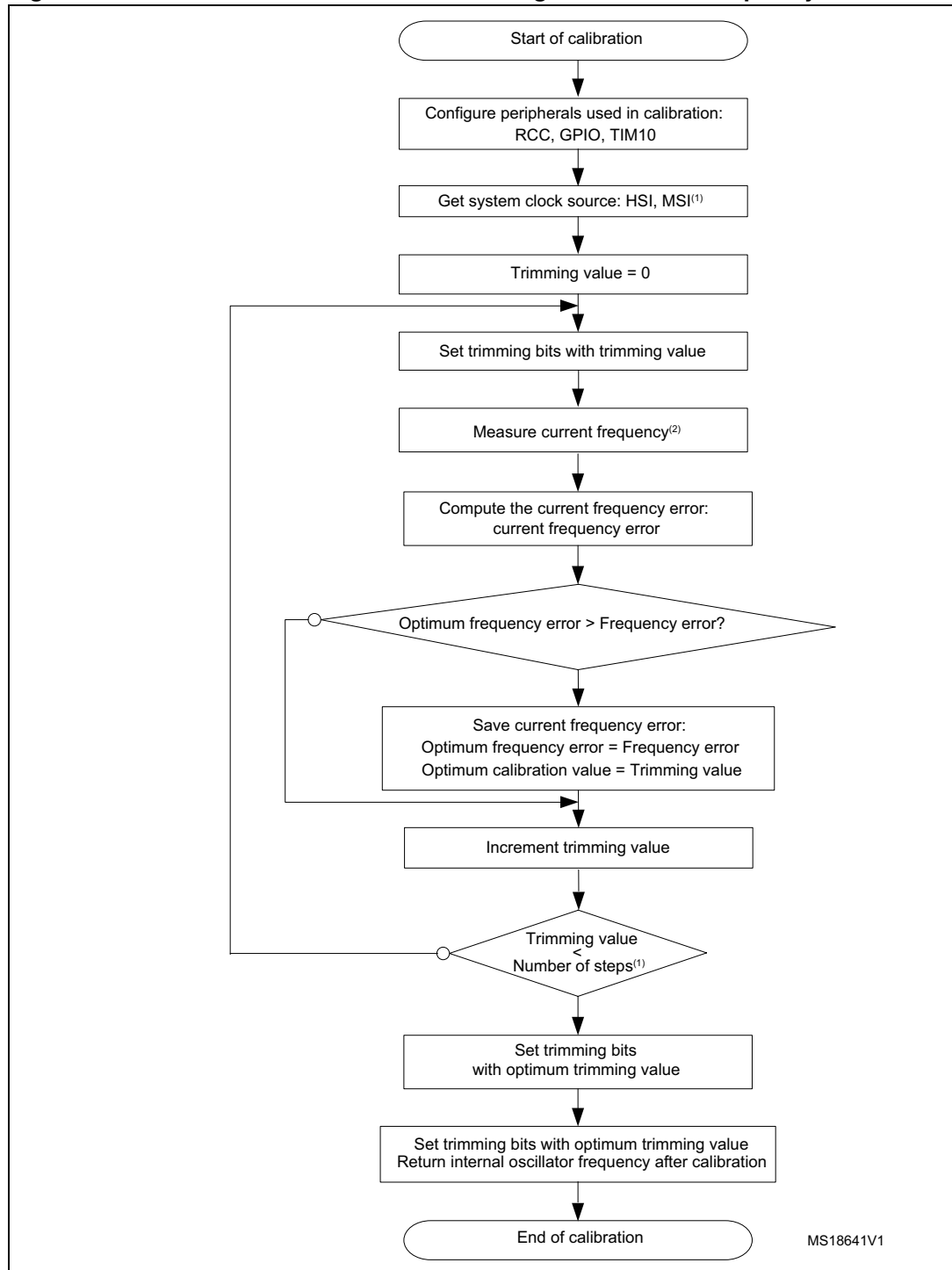

1. If the system clock source is HSI, the trimming bits have a 5-bit length and the number of steps is 32. If the system clock source is MSI, the trimming bits have an 8-bit length and the number of steps is 256.
2. Frequency measurement is detailed in [Section 2.3.4](#).

2.3.2 HSI calibration with fixed error

The `HSI_CalibrateFixedError()` function is provided to calibrate the HSI oscillator with a maximum allowed frequency error. It is configured by the user as an absolute value given in Hertz (the first parameter: *MaxAllowedError*). This function is the same as `InternOsc_CalibrateMinError()` (refer to [Section 2.3.1: Internal oscillator calibration with minimum error](#)), but it searches for the frequency that has an error (in absolute value) lower than or equal to *MaxAllowedError*.

- If it finds this frequency, it stops searching and configures the trimming bits `HSITRIM[4:0]` according to this frequency and returns `SUCCESS`, meaning that the calibration operation has succeeded.
- Otherwise, it continues searching for it until the `HSITRIM` bits = 31 (32nd frequency). It then sets the trimming bits `HSITRIM[4:0]` to the default calibration value and returns `ERROR`, meaning that the calibration has failed and did not find any frequency with an error lower than or equal to *MaxAllowedError*.

The frequency measurement starts with `HSTRIM` = 16. The `HSITRIM` value is computed in loops to find the next value. That is, the `HSITRIM` value starts from 16, then goes to the next value to the left, then to the next to the right, then to the second to the left and so on until it reaches 31, forming a “spring loop” (as shown in [Figure 8](#)).

This algorithm is based on the fact that the probability of finding the frequency that has the minimum error increases when the `HSITRIM[4:0]` value tends to 16. This algorithm is implemented so as to minimize the time consumed by the calibration process.

Figure 8. “Spring loop”

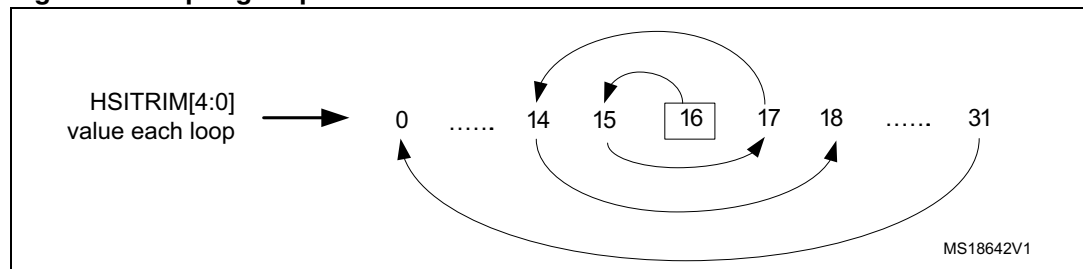

The second parameter is used to get the frequency (in Hertz) after calibration in the form of an unsigned 32-bit integer (`unit32_t`).

The flowchart in [Figure 9](#) provides the algorithm for this function.

Figure 9. HSI calibration flowchart: maximum allowed frequency error

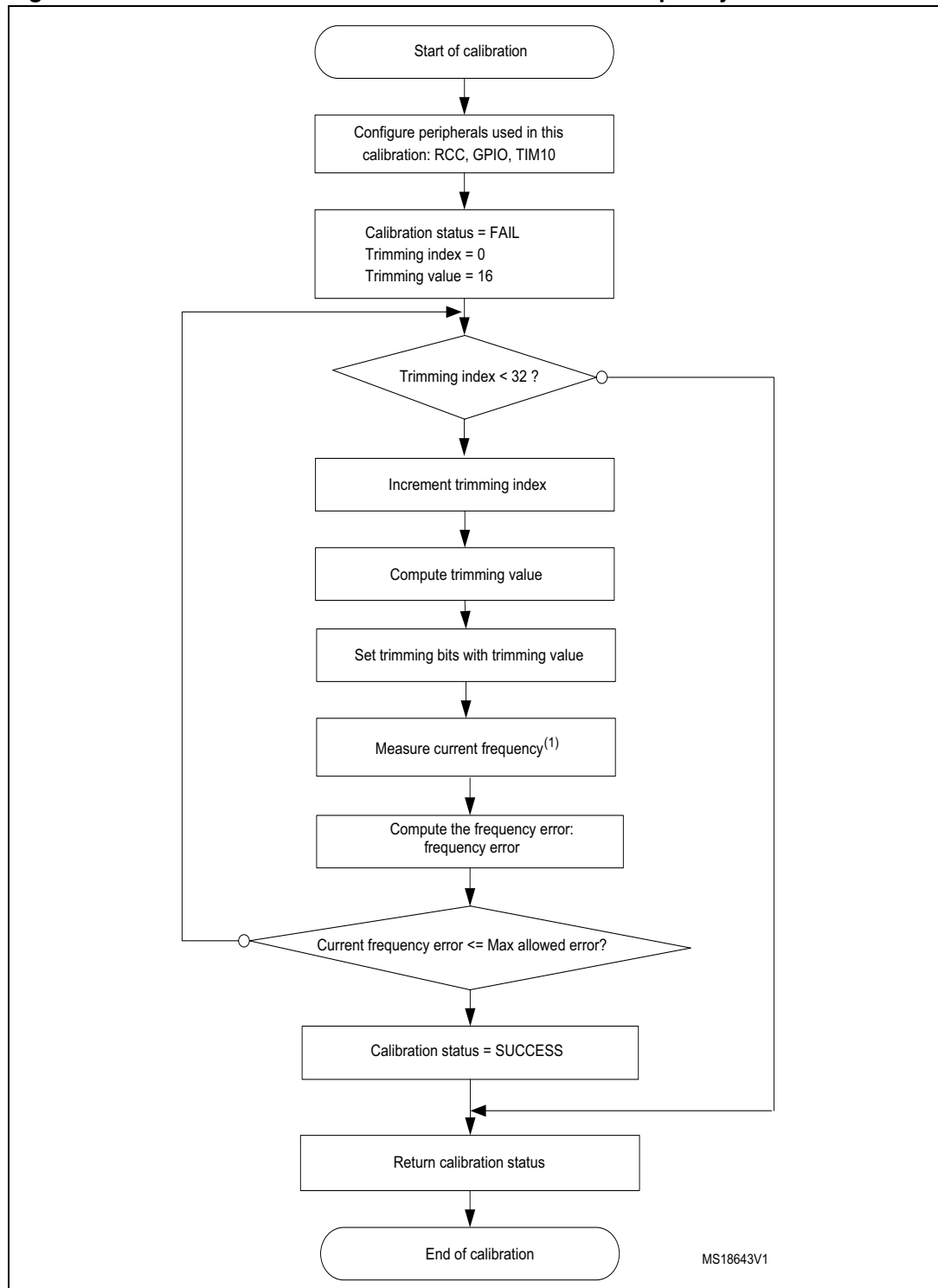

1. Frequency measurement is detailed in [Section 2.3.4: Internal oscillator frequency measurement](#).

2.3.3 MSI calibration with fixed error

The `MSI_CalibrateFixedError()` function is provided to calibrate the MSI oscillator with a maximum allowed frequency error in minimum time (by avoiding scan of all 256 trimming values). The allowed error is configured by the user as an absolute value given in Hertz (the first parameter: *MaxAllowedError*). This function is the same as `HSI_CalibrateFixedError()` (refer to [Section 2.3.1: Internal oscillator calibration with minimum error](#)), with the exception that it calibrates the MSI oscillator using a binary search algorithm.

The flowchart in [Figure 10](#) provides the algorithm for this function.

Figure 10. MSI calibration flowchart: maximum allowed frequency error

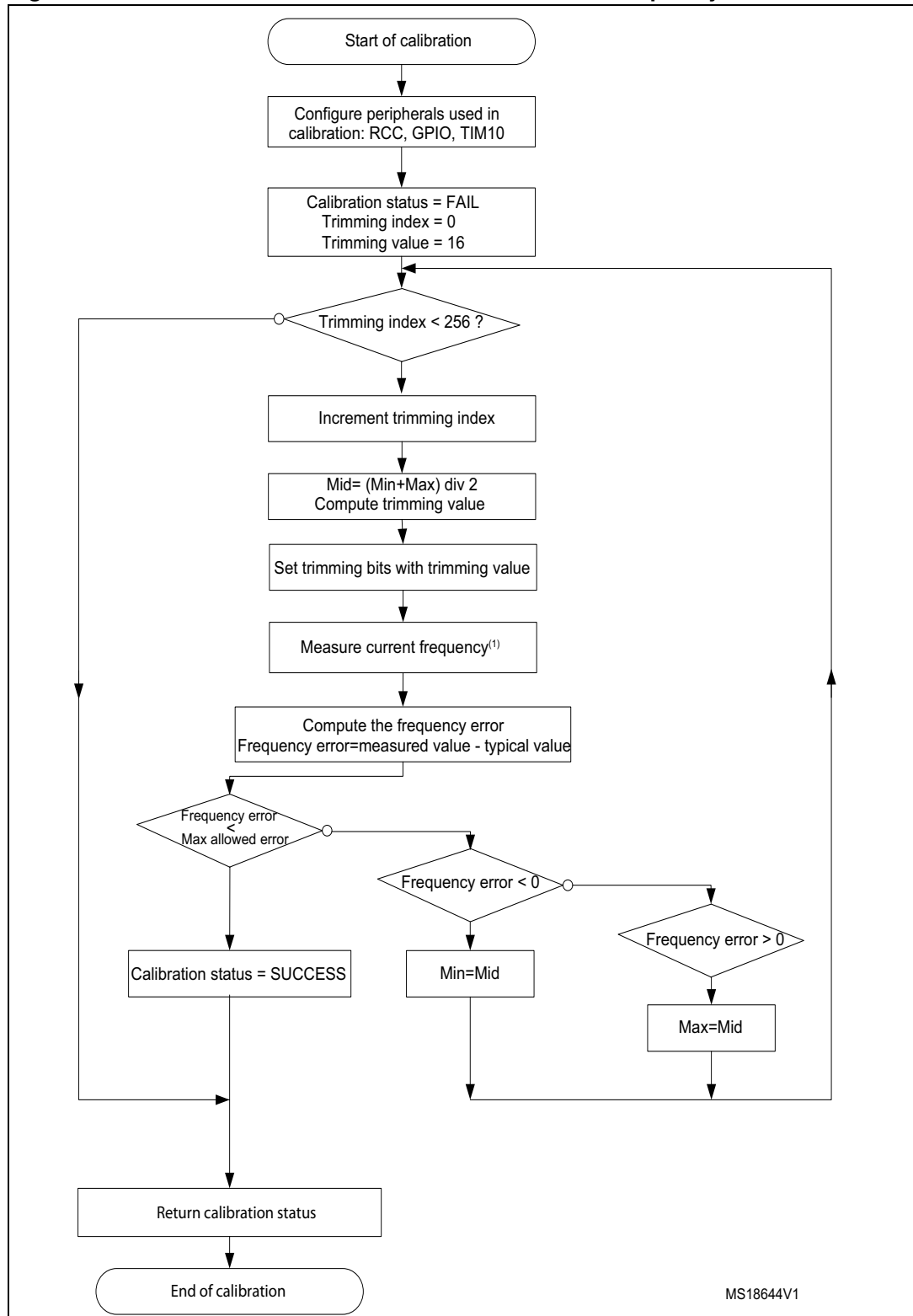

1. Frequency measurement is detailed in [Section 3: Internal oscillator measurement](#).

2.3.4 Internal oscillator frequency measurement

Internal oscillator frequency measurement is performed by Timer 10 capture interrupt. In the timer TIM10 ISR, an entire period of internal oscillator frequency is computed. The number of periods to be measured for each trimming value is configurable by the user in the *InternOscCalibration.h* file as follows:

```
#define NUMBER_OF_LOOPS 10 /* Number of periods to be measured = 10
*/
```

The averaging method is used to minimize frequency error measurements. So, if the counter of loops reaches NUMBER_OF_LOOPS, the average of all measured frequencies is computed.

You can easily configure the frequency of the reference source. It is defined in the header file *InternOscCalibration.h* as follows:

- If the LSE clock is used as the reference frequency, uncomment the line below to make sure the LSE is configured and internally connected to Timer 10 channel 1:

```
#define USE_REFERENCE_LSE
```

- If the reference frequency is a mains source frequency equal to 50 Hz, then comment the line above and define the reference frequency as shown below:

```
#define REFERENCE_FREQUENCY (uint32_t)50 /* The reference
frequency value in Hz */
```

The computation of the frequency measurements does not depend on the duty cycle of the source reference signal. It depends on its frequency since the capture 1 interrupt is configured to occur on every rising edge of the reference signal (refer to [Figure 4](#)).

Note: [Figure 11](#) provides the frequency measurement algorithm.

Figure 11. Internal oscillator frequency measurement flowchart

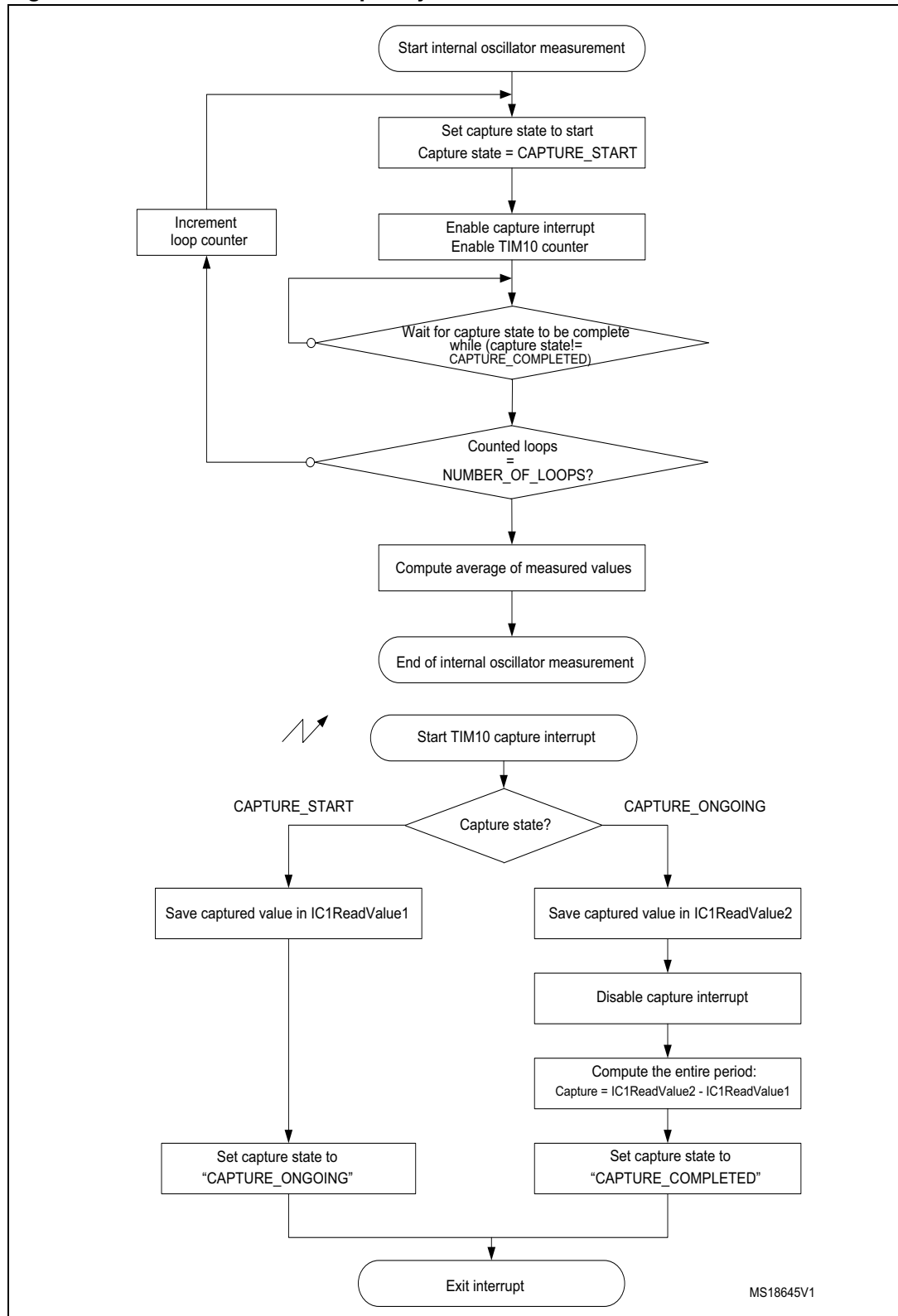

MS18645V1

2.4 Recommendations on the use of the calibration library

1. If external signal frequency is lower than system clock / 65535, the TIM10 counter prescaler should be used to support low frequencies.
2. If external signal frequency is higher than system clock / 100, TIM10 input capture prescaler (divider) should be used to support high frequencies.
3. It is recommended to stop all application activities before the calibration process, and to restart them after calling the calibration functions.

The application therefore has to stop communications, ADC measurements and other processes (except when using the ADC for the calibration, refer to Step 5. below).

These processes normally use clock configurations that are different from those used in the calibration process. Otherwise, errors might be introduced in the application: errors while reading/sending frames, ADC reading errors since the sampling time has changed, and so on.

4. The internal RC oscillator calibration firmware uses the following peripherals: Reset and Clock Control (for trimming internal RC oscillators), Timer 10 (for measuring internal RC oscillators). Therefore, it is recommended to reconfigure these peripherals (if used in the application) after running the calibration routine.
5. Real-time calibration vs. temperature can be used when the ambient temperature changes noticeably while the application is running. The internal temperature sensor can be used with the ADC watchdog with two thresholds. Each time an ADC watchdog interrupt occurs, a new calibration process has to be performed and the two thresholds are updated according to the current temperature (this feature is not implemented in the firmware provided with this application note):

Threshold_High = CurrentTemperatureValue + TemperatureOffset

Threshold_Low = CurrentTemperatureValue – TemperatureOffset

2.5 Calibration process performance

2.5.1 Duration of the calibration process

The duration of the calibration process depends on:

1. the frequency of the reference signal (prescaled value) "REFERENCE_FREQUENCY",
2. the number of measured periods per trimming value "NUMBER_OF_LOOPS",
3. the number of measured frequencies during the calibration process "number of steps".

Once the peripherals are configured and ready (mainly the LSE oscillator), the duration of the calibration process is approximated by:

$$\text{duration} = (2 \times (\text{NUMBER_OF_LOOPS} + 1) \times \text{number of steps}) / \text{REFERENCE_FREQUENCY}$$

If the calibration process is run with a minimum frequency error for HSI oscillator (*InternOsc_CalibrateMinError()*), the number of steps is equal to 32. If the LSE oscillator is used as the reference frequency (REFERENCE_FREQUENCY = LSE value / Input capture prescaler = 32768/8 = 4096 Hz) and the selected number of measured periods is 10, the calibration consumes approximately:

$$\text{duration} = (2 \times 11 \times 32) / 4096 = 172 \text{ ms}$$

When running the calibration process for the MSI oscillator, the number of steps is equal to 256. If the LSE oscillator is used as the reference frequency ($\text{REFERENCE_FREQUENCY} = \text{LSE value} / \text{Input capture prescaler} = 32768/8 = 4096 \text{ Hz}$) and the selected number of measured periods is 10, the calibration consumes approximately:

$$\text{duration} = (2 \times 11 \times 256) / 4096 = 1.4 \text{ s}$$

The duration of the calibration process with a maximum allowed error is lower than or equal to the duration of calibration when using the minimum frequency error process.

Note: Multiplying by 2 in the duration formula above is due to the fact that there is no synchronization between the reference signal and the start of counting by the timer.

3 Internal oscillator measurement

The internal MSI and LSI RC oscillators are low-power and low-cost clock sources. In the STM32L1x microcontroller family, an internal connection is provided between the internal RC oscillators (MSI and LSI) and the embedded timers (TIM10 and TIM11) to facilitate the measurement procedure.

3.1 Measurement principle

The internal RC oscillator measurement procedure consists in running the timer counter using the HSI clock, configuring the timer in Input capture mode and then connecting the internal RC oscillator (that needs to be measured) to the timer.

The following figure shows the configuration used to perform the MSI measurement. As shown, TIM11 can be connected internally to TIM11 Input 1 (TI1).

Figure 12. MSI measurement configuration

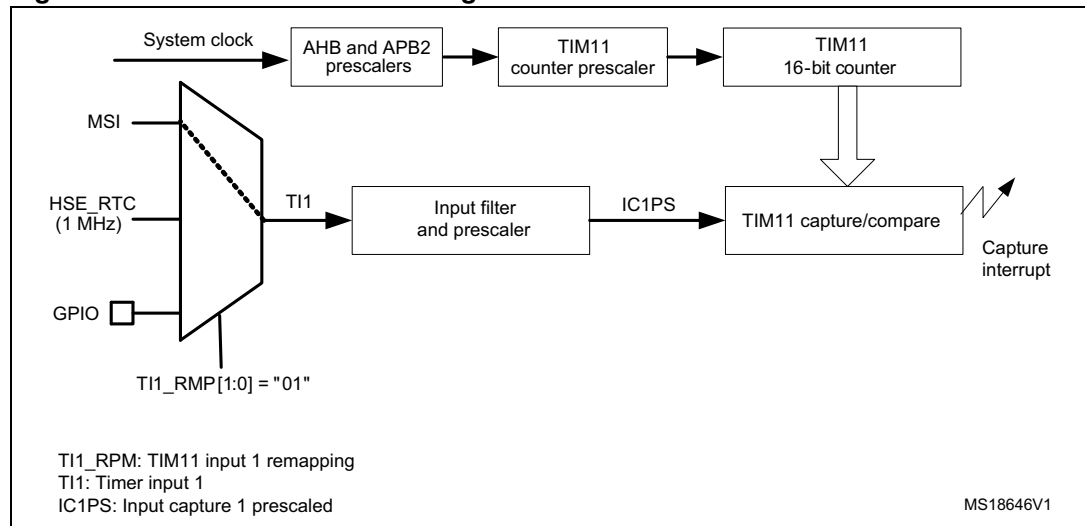

The next figure shows the configuration used to perform LSI measurement. As shown, TIM10 can be connected internally to TIM10 Input 1 (TI1).

Figure 13. LSI measurement configuration

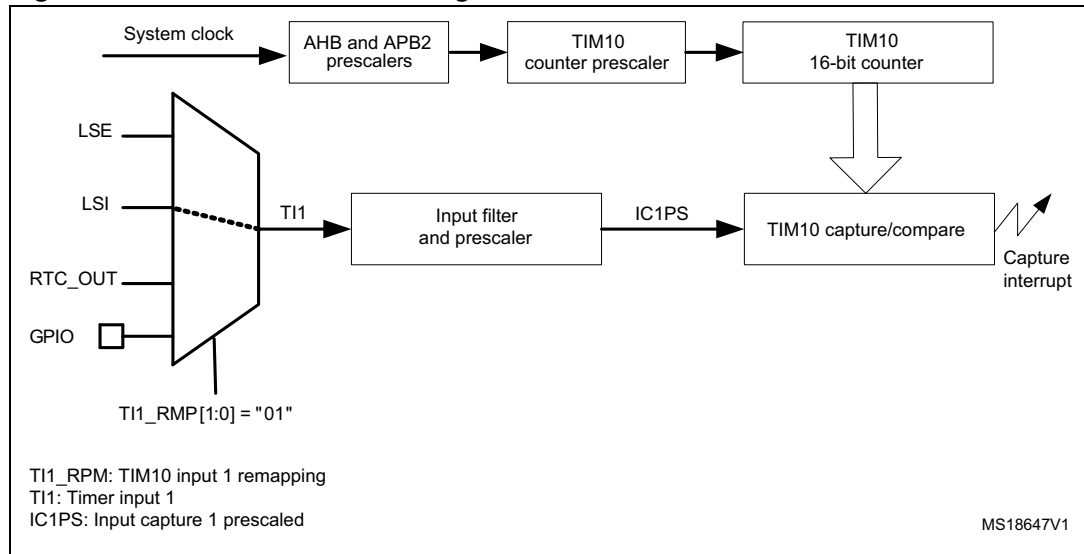

After enabling the timer counter, when the first rising edge of the internal oscillator signal to be measured occurs, the timer counter value is captured and then stored in IC1ReadValue1. On the second rising edge, the timer counter is captured again and stored in IC1ReadValue2. The elapsed time between two consecutive rising edges of the clock represents an entire period. The following figure shows the timing diagram of an internal RC oscillator measurement.

Figure 14. Timing diagram of an internal RC oscillator measurement

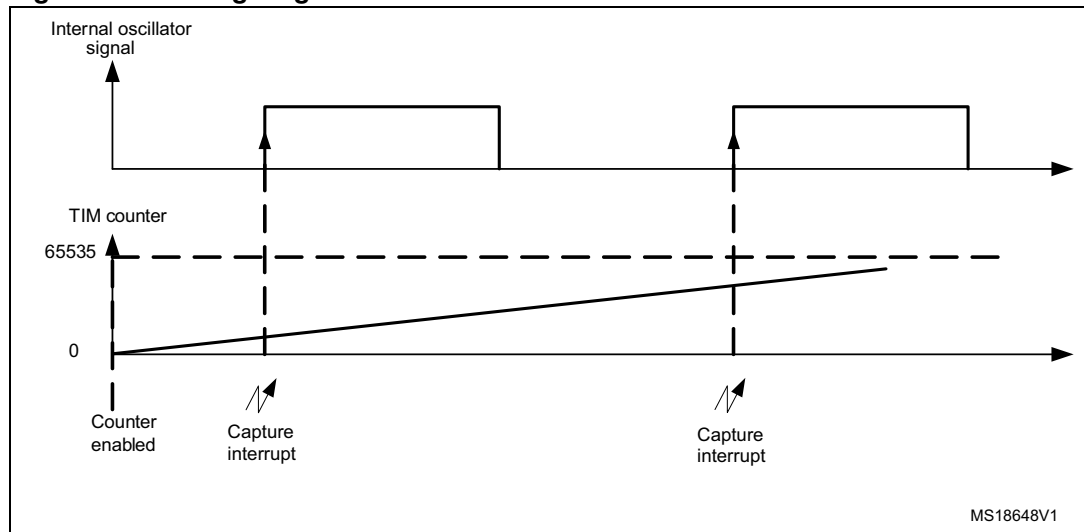

The internal oscillator frequency value is computed as shown by the following formula:

$$\text{internal oscillator frequency} = \text{HSI_Value} / \text{Capture}$$

where:

- HSI_Value is the HSI frequency value: typical value is 16 MHz,
- Capture represents an entire period of internal RC oscillator (MSI or LSI): IC1ReadValue2 - IC1ReadValue1.

As you can conclude from the formula above, the frequency measurement accuracy depends on the HSI frequency accuracy. Consequently, if a reference signal is available, you can run the internal RC oscillator calibration routine described in [Section 2: Internal RC oscillator calibration](#) before performing the internal RC oscillator measurement procedure.

The input capture prescaler can be used for better measurement accuracy so the formula above becomes:

$$\text{LSI_Frequency} = \text{InputCapturePrescaler} * \text{HSI_Value} / \text{Capture_Value}.$$

The same algorithm as shown in [Figure 11](#) is used to measure the LSI and MSI oscillator frequency. Note that TIM10 ISR is used for MSI measurement and TIM11 ISR is used for LSI measurement.

3.2 Description of the internal oscillator measurement firmware

The internal oscillator measurement firmware provided with this application note includes two C source files:

- LSIMeasurement.c performing LSI frequency measurement using LSI_FreqMeasure() function
- MSIMeasurement.c performing MSI frequency measurement using MSI_FreqMeasure() function

The internal RC oscillators (MSI or LSI) are measured for a predefined number of periods. Then it returns the average value to minimize the error of the measured frequency.

You can change this parameter (number of LSI periods) in the lsi_measurement.h file:

```
#define LSI_PERIOD_NUMBERS 10
```

In the same way, the number of periods can be changed in the msi_measurement.h:

```
#define MSI_PERIOD_NUMBERS 10
```

3.3 Internal oscillator calibration/measurement demo description

The demo provided with this application note shows the ability of the firmware to calibrate the internal RC oscillators (HSI and MSI) and gives an example of how to use it to measure the internal RC oscillators (MSI and LSI) of the STM32L1x microcontroller.

Before running the calibration routine, select the system clock source in system_STM32L1xx.c. If the HSI (rep. MSI) oscillator is selected as the system clock source, HSI (or MSI) is calibrated. In this demo, the internal RC oscillator (MSI or HSI) is calibrated using the LSE oscillator as a reference.

By default, the demo uses the minimum error method to calibrate HSI oscillators.

To run the calibration process that provides the frequency with fixed error, you have to comment out the following define in the main.c file.

```
#define CALIBRATION_MIN_ERROR
```

Figure 15 below shows the message displayed on the LCD implemented on the STM32L1xx-EVAL board when running the demo with HSI selected as the system clock source. The HSI oscillator is calibrated, then both MSI and LSI oscillators are measured.

Figure 15. HSI calibration

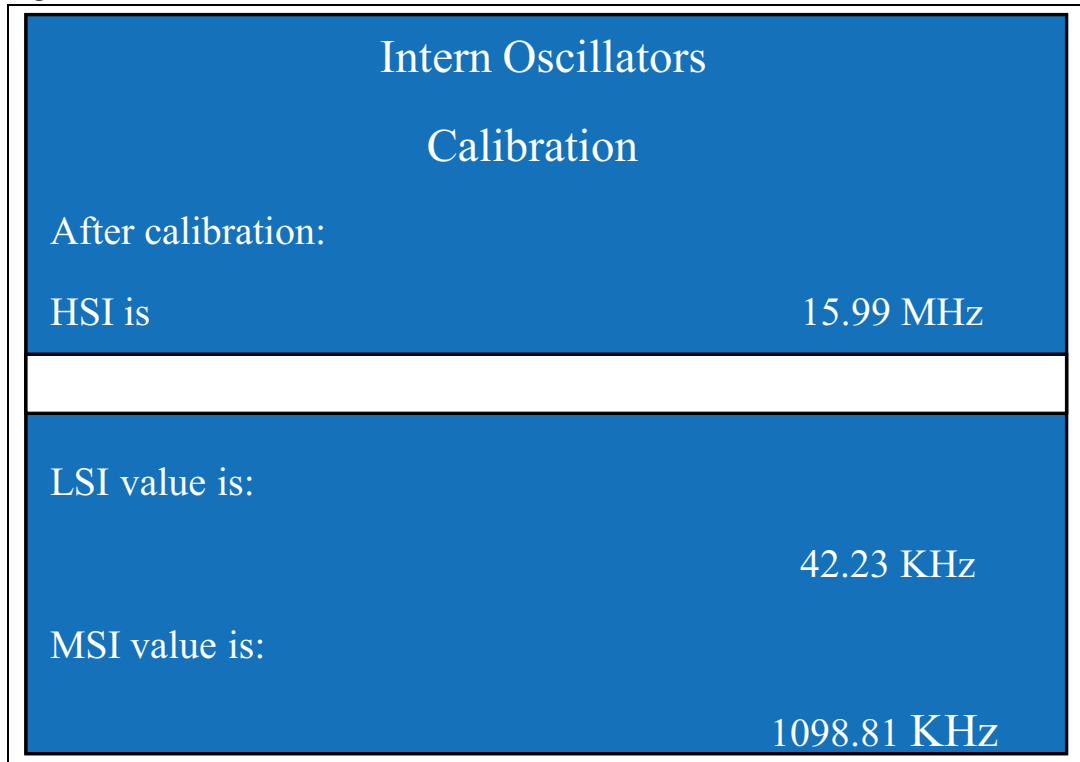

The next figure shows the message displayed on the LCD when running the demo with MSI selected as the system clock source. MSI is calibrated at 4 MHz, then the LSI frequency is measured.

Figure 16. MSI calibration

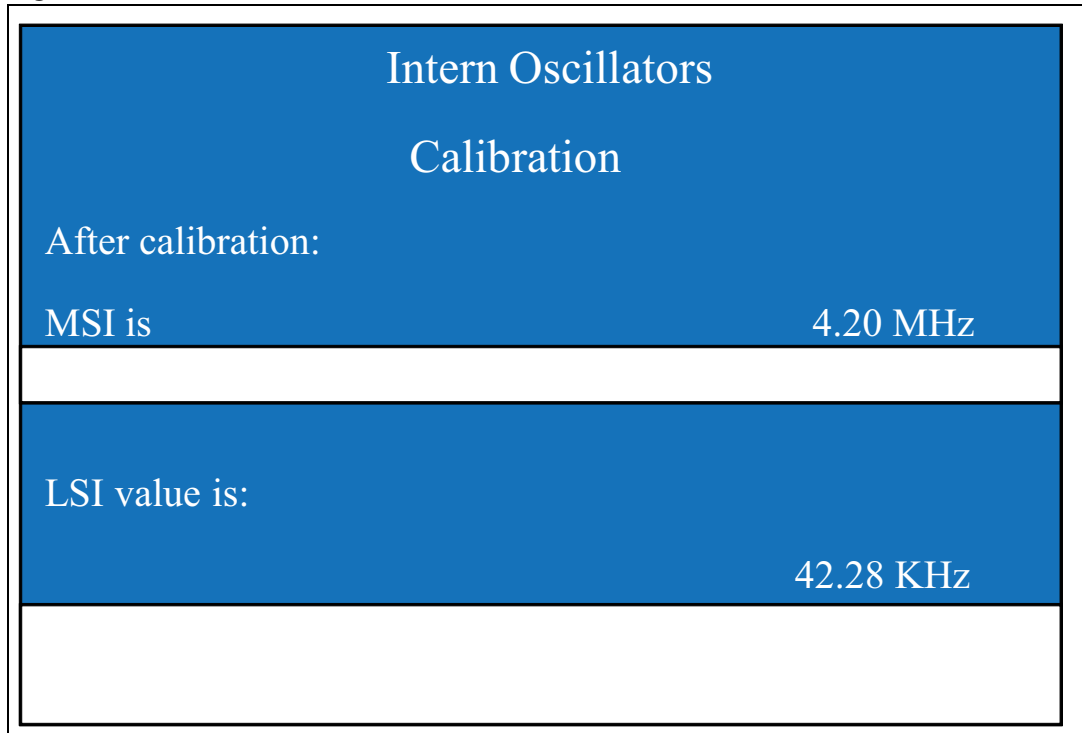

4 Conclusion

Even if internal RC oscillators are factory-calibrated, the user should calibrate them in the operating environment if a high-accuracy clock is required in the application.

This application note provides two routines:

- **Multi- and High-Speed Internal oscillator calibration:** how to fine-tune the oscillator to the typical value
- **Multi- and Low-Speed Internal oscillator measurement:** how to get the “exact” LSI/MSI frequency value

Several frequency sources can be used to calibrate the internal RC oscillators (HSI and MSI): LSE crystal, AC line, etc. Whatever the reference frequency source, the internal oscillator calibration principle is the same: a reference signal must be provided to be measured by a timer. The higher the accuracy of the reference signal frequency, the better the accuracy of the internal oscillator frequency measurement. The error is computed as the absolute value of the typical frequency value and the measured one for each trimming value. From this, the calibration value is calculated and then programmed in the trimming bits.

The second section of this application note discussed the measurement of LSI and MSI oscillators. The internal connection between internal oscillators and embedded timers in the STM32L1xx microcontroller family is used for this purpose. The timer is clocked using the system clock source and configured in Input capture mode. The captured time between two consecutive rising edges of internal oscillator represents an entire period.

5 Revision history

Table 1. Document revision history

Date	Revision	Changes
07-Apr-2011	1	Initial release.
31-Jan-2012	2	Notes added to the Cover page to include Ultra Low Power Medium-density Plus and Ultra Low Power High-density devices.

Please Read Carefully:

Information in this document is provided solely in connection with ST products. STMicroelectronics NV and its subsidiaries ("ST") reserve the right to make changes, corrections, modifications or improvements, to this document, and the products and services described herein at any time, without notice.

All ST products are sold pursuant to ST's terms and conditions of sale.

Purchasers are solely responsible for the choice, selection and use of the ST products and services described herein, and ST assumes no liability whatsoever relating to the choice, selection or use of the ST products and services described herein.

No license, express or implied, by estoppel or otherwise, to any intellectual property rights is granted under this document. If any part of this document refers to any third party products or services it shall not be deemed a license grant by ST for the use of such third party products or services, or any intellectual property contained therein or considered as a warranty covering the use in any manner whatsoever of such third party products or services or any intellectual property contained therein.

UNLESS OTHERWISE SET FORTH IN ST'S TERMS AND CONDITIONS OF SALE ST DISCLAIMS ANY EXPRESS OR IMPLIED WARRANTY WITH RESPECT TO THE USE AND/OR SALE OF ST PRODUCTS INCLUDING WITHOUT LIMITATION IMPLIED WARRANTIES OF MERCHANTABILITY, FITNESS FOR A PARTICULAR PURPOSE (AND THEIR EQUIVALENTS UNDER THE LAWS OF ANY JURISDICTION), OR INFRINGEMENT OF ANY PATENT, COPYRIGHT OR OTHER INTELLECTUAL PROPERTY RIGHT.

UNLESS EXPRESSLY APPROVED IN WRITING BY TWO AUTHORIZED ST REPRESENTATIVES, ST PRODUCTS ARE NOT RECOMMENDED, AUTHORIZED OR WARRANTED FOR USE IN MILITARY, AIR CRAFT, SPACE, LIFE SAVING, OR LIFE SUSTAINING APPLICATIONS, NOR IN PRODUCTS OR SYSTEMS WHERE FAILURE OR MALFUNCTION MAY RESULT IN PERSONAL INJURY, DEATH, OR SEVERE PROPERTY OR ENVIRONMENTAL DAMAGE. ST PRODUCTS WHICH ARE NOT SPECIFIED AS "AUTOMOTIVE GRADE" MAY ONLY BE USED IN AUTOMOTIVE APPLICATIONS AT USER'S OWN RISK.

Resale of ST products with provisions different from the statements and/or technical features set forth in this document shall immediately void any warranty granted by ST for the ST product or service described herein and shall not create or extend in any manner whatsoever, any liability of ST.

ST and the ST logo are trademarks or registered trademarks of ST in various countries.

Information in this document supersedes and replaces all information previously supplied.

The ST logo is a registered trademark of STMicroelectronics. All other names are the property of their respective owners.

© 2012 STMicroelectronics - All rights reserved

STMicroelectronics group of companies

Australia - Belgium - Brazil - Canada - China - Czech Republic - Finland - France - Germany - Hong Kong - India - Israel - Italy - Japan - Malaysia - Malta - Morocco - Philippines - Singapore - Spain - Sweden - Switzerland - United Kingdom - United States of America

www.st.com