

Description

The TS555 is a single CMOS timer with very low consumption:

($I_{CC(TYP)}$ TS555 = 110 μ A at V_{CC} = +5 V versus $I_{CC(TYP)}$ NE555^(a) = 3 mA),

and high frequency:

($f_{f(max.)}$ TS555 = 2.7 MHz versus $f_{(max)}$ NE555^(a) = 0.1 MHz).

Timing remains accurate in both monostable and astable mode.

The TS555 provides reduced supply current spikes during output transitions, which enable the use of lower decoupling capacitors compared to those required by bipolar NE555^(a).

With the high input impedance ($10^{12}\Omega$), timing capacitors can also be minimized.

Features

- Very low power consumption:
 - 110 μ A typ at V_{CC} = 5 V
 - 90 μ A typ at V_{CC} = 3 V
- High maximum astable frequency of 2.7 MHz
- Pin-to-pin functionally-compatible with bipolar NE555^(a)
- Wide voltage range: +2 V to +16 V
- Supply current spikes reduced during output transitions
- High input impedance: $10^{12}\Omega$
- Output compatible with TTL, CMOS and logic MOS

a. Terminated product

Contents

1	Absolute maximum ratings and operating conditions	3
2	Schematic diagrams	4
3	Electrical characteristics	6
4	Application information	13
	4.1 Monostable operation	13
	4.2 Astable operation	14
5	Package information	15
	5.1 SO8 package information	16
6	Ordering information	17
7	Revision history	18

1 Absolute maximum ratings and operating conditions

Table 1. Absolute maximum ratings

Symbol	Parameter	Value	Unit
V _{CC}	Supply voltage	+18	V
I _{OUT}	Output current	± 100	mA
R _{thja}	Thermal resistance junction to ambient ⁽¹⁾	125	°C/W
R _{thjc}	Thermal resistance junction to case ⁽¹⁾	40	
T _j	Junction temperature	+150	°C
T _{stg}	Storage temperature range	-65 to +150	
ESD	Human body model (HBM) ⁽²⁾	1500	V
	Machine model (MM) ⁽³⁾	200	
	Charged device model (CDM) ⁽⁴⁾	1000	

1. Short-circuits can cause excessive heating. These values are typical and specified for a four layers PCB.
2. Human body model: a 100 pF capacitor is charged to the specified voltage, then discharged through a 1.5kΩ resistor between two pins of the device. This is done for all couples of connected pin combinations while the other pins are floating.
3. Machine model: a 200 pF capacitor is charged to the specified voltage, then discharged directly between two pins of the device with no external series resistor (internal resistor < 5 Ω). This is done for all couples of connected pin combinations while the other pins remain floating.
4. Charged device model: all pins plus package are charged together to the specified voltage and then discharged directly to the ground.

Table 2. Operating conditions

Symbol	Parameter	Value	Unit
V _{CC}	Supply voltage	2 to 16	V
I _{OUT}	Output sink current	50	mA
	Output source current	10	
T _{oper}	Operating free air temperature range	-40 to +125	°C

2 Schematic diagrams

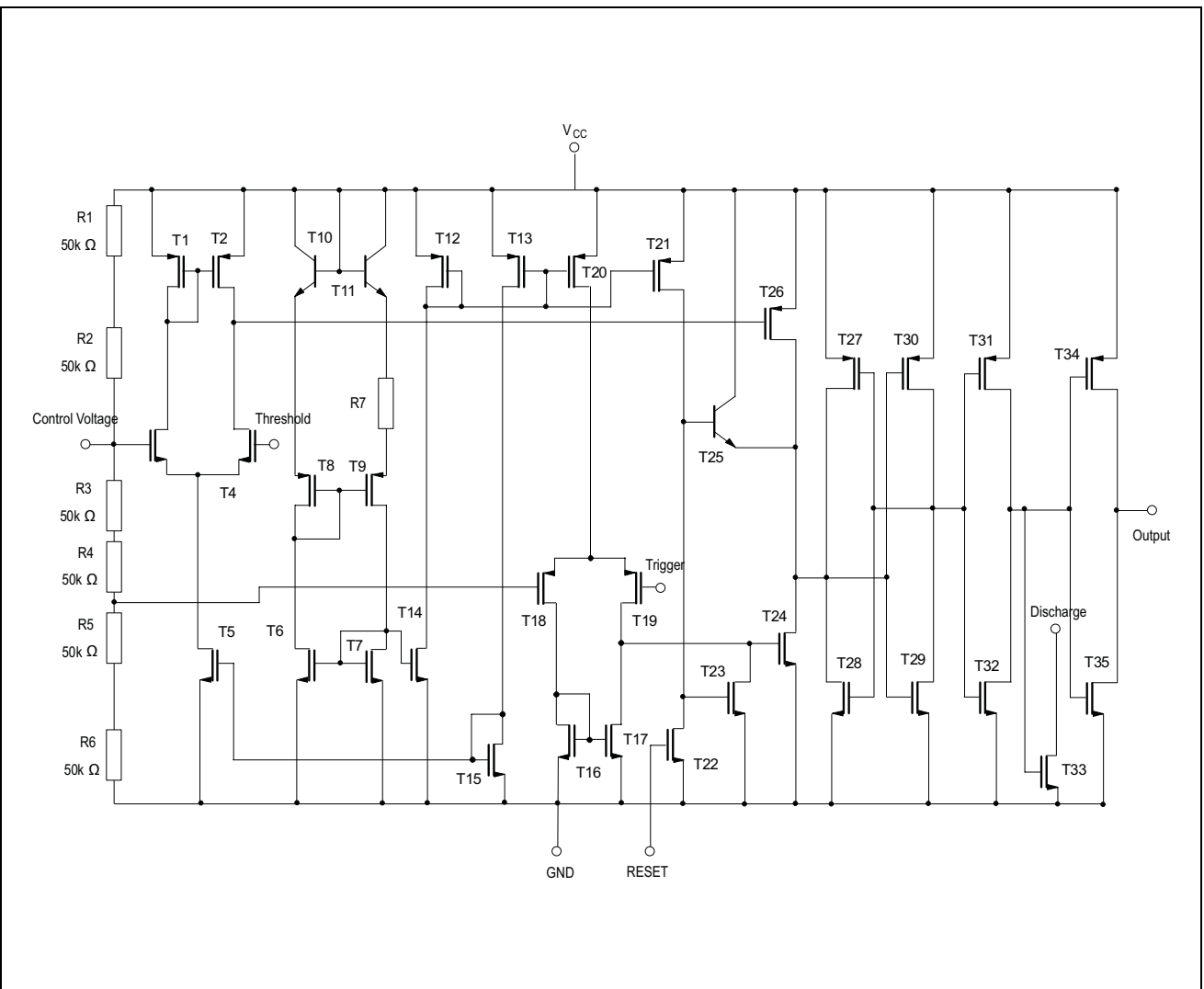

Figure 1. Schematic diagram

Figure 2. Block diagram

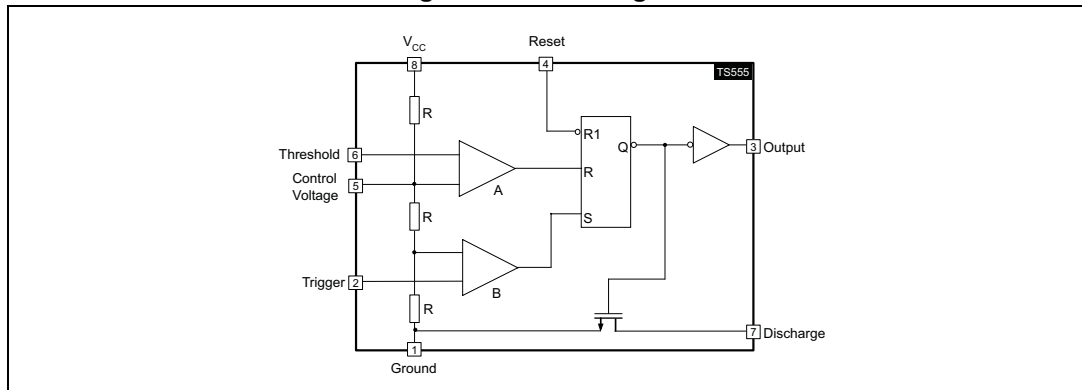

Table 3. Functional table

Reset	Trigger	Threshold	Output
Low	x	x	Low
High	Low		High
	High	High	Low
		Low	Previous state

Note: *Low: level voltage ≤ minimum voltage specified*
High: level voltage ≥ maximum voltage specified
x: irrelevant

3 Electrical characteristics

Table 4. Static electrical characteristics
V_{CC} = +2 V, T_{amb} = +25 °C, reset to V_{CC} (unless otherwise specified)

Symbol	Parameter	Min.	Typ.	Max.	Unit
I _{CC}	Supply current (no load, high and low states) T _{min} ≤ T _{amb} ≤ T _{max}		65	200 200	μA
V _{CL}	Control voltage level T _{min} ≤ T _{amb} ≤ T _{max}	1.2 1.1	1.3	1.4 1.5	V
V _{DIS}	Discharge saturation voltage (I _{dis} = 1 mA) T _{min} ≤ T _{amb} ≤ T _{max}		0.05	0.2 0.25	
I _{DIS}	Discharge pin leakage current		1	100	nA
V _{OL}	Low level output voltage (I _{sink} = 1 mA) T _{min} ≤ T _{amb} ≤ T _{max}		0.1	0.3 0.35	V
V _{OH}	High level output voltage (I _{source} = -0.3 mA) T _{min} ≤ T _{amb} ≤ T _{max}	1.5 1.5	1.9		
V _{TRIG}	Trigger voltage T _{min} ≤ T _{amb} ≤ T _{max}	0.4 0.3	0.67	0.95 1.05	
I _{TRIG}	Trigger current		10		pA
I _{TH}	Threshold current		10		
V _{RESET}	Reset voltage T _{min} ≤ T _{amb} ≤ T _{max}	0.4 0.3	1.1	1.5 2.0	V
I _{RESET}	Reset current		10		pA

Table 5. Static electrical characteristics
 $V_{CC} = +3\text{ V}$, $T_{amb} = +25\text{ °C}$, reset to V_{CC} (unless otherwise specified)

Symbol	Parameter	Min.	Typ.	Max.	Unit
I_{CC}	Supply current (no load, high and low states) $T_{min} \leq T_{amb} \leq T_{max}$		90	230 230	μA
V_{CL}	Control voltage level $T_{min} \leq T_{amb} \leq T_{max}$	1.8 1.7	2	2.2 2.3	V
V_{DIS}	Discharge saturation voltage ($I_{dis} = 1\text{ mA}$) $T_{min} \leq T_{amb} \leq T_{max}$		0.05	0.2 0.25	
I_{DIS}	Discharge pin leakage current		1	100	nA
V_{OL}	Low level output voltage ($I_{sink} = 1\text{ mA}$) $T_{min} \leq T_{amb} \leq T_{max}$		0.1	0.3 0.35	V
V_{OH}	High level output voltage ($I_{source} = -0.3\text{ mA}$) $T_{min} \leq T_{amb} \leq T_{max}$	2.5 2.5	2.9		
V_{TRIG}	Trigger voltage $T_{min} \leq T_{amb} \leq T_{max}$	0.9 0.8	1	1.1 1.2	
I_{TRIG}	Trigger current		10		pA
I_{TH}	Threshold current		10		
V_{RESET}	Reset voltage $T_{min} \leq T_{amb} \leq T_{max}$	0.4 0.3	1.1	1.5 2.0	V
I_{RESET}	Reset current		10		pA

Table 6. Dynamic electrical characteristics
 $V_{CC} = +3\text{ V}$, $T_{amb} = +25\text{ }^{\circ}\text{C}$, reset to V_{CC} (unless otherwise specified)

Symbol	Parameter	Min.	Typ.	Max.	Unit
	Timing accuracy (monostable) ⁽¹⁾ $R = 10\text{ k}\Omega$, $C = 0.1\text{ }\mu\text{F}$ $V_{CC} = 2\text{ V}$ $V_{CC} = 3\text{ V}$		1 1		%
	Timing shift with supply voltage variations (monostable) $R = 10\text{ k}\Omega$, $C = 0.1\text{ }\mu\text{F}$, $V_{CC} = 3\text{ V} \pm 0.3\text{ V}$ ⁽¹⁾		0.5		%/V
	Timing shift with temperature ⁽¹⁾ $T_{min} \leq T_{amb} \leq T_{max}$		75		ppm/ $^{\circ}\text{C}$
f_{max}	Maximum astable frequency ⁽²⁾ $R_A = 470\text{ }\Omega$, $R_B = 200\text{ }\Omega$, $C = 200\text{ pF}$	—	2	—	MHz
	Astable frequency accuracy ⁽²⁾ $R_A = R_B = 1\text{ k}\Omega$ to $100\text{ k}\Omega$, $C = 0.1\text{ }\mu\text{F}$		5		%
	Timing shift with supply voltage variations (astable mode) ⁽²⁾ $R_A = R_B = 1\text{ k}\Omega$ to $100\text{ k}\Omega$, $C = 0.1\text{ }\mu\text{F}$, $V_{CC} = 3$ to 5 V		0.5		%/V
t_R	Output rise time ($C_{load} = 10\text{ pF}$)		25		ns
t_F	Output fall time ($C_{load} = 10\text{ pF}$)		20		
t_{PD}	Trigger propagation delay		100		
t_{RPW}	Minimum reset pulse width ($V_{trig} = 3\text{ V}$)		350		

1. See [Figure 4](#)

2. See [Figure 6](#)

Table 7. Static electrical characteristics
 $V_{CC} = +5\text{ V}$, $T_{amb} = +25\text{ °C}$, reset to V_{CC} (unless otherwise specified)

Symbol	Parameter	Min.	Typ.	Max.	Unit
I_{CC}	Supply current (no load, high and low states) $T_{min} \leq T_{amb} \leq T_{max}$		110	250 250	μA
V_{CL}	Control voltage level $T_{min} \leq T_{amb} \leq T_{max}$	2.9 2.8	3.3	3.8 3.9	V
V_{DIS}	Discharge saturation voltage ($I_{dis} = 10\text{ mA}$) $T_{min} \leq T_{amb} \leq T_{max}$		0.2	0.3 0.35	
I_{DIS}	Discharge pin leakage current		1	100	nA
V_{OL}	Low level output voltage ($I_{sink} = 8\text{ mA}$) $T_{min} \leq T_{amb} \leq T_{max}$		0.3	0.6 0.8	V
V_{OH}	High level output voltage ($I_{source} = -2\text{ mA}$) $T_{min} \leq T_{amb} \leq T_{max}$	4.4 4.4	4.6		
V_{TRIG}	Trigger voltage $T_{min} \leq T_{amb} \leq T_{max}$	1.36 1.26	1.67	1.96 2.06	
I_{TRIG}	Trigger current		10		pA
I_{TH}	Threshold current		10		
V_{RESET}	Reset voltage $T_{min} \leq T_{amb} \leq T_{max}$	0.4 0.3	1.1	1.5 2.0	V
I_{RESET}	Reset current		10		pA

Table 8. Dynamic electrical characteristics
V_{CC} = +5 V, T_{amb} = +25 °C, reset to V_{CC} (unless otherwise specified)

Symbol	Parameter	Min.	Typ.	Max.	Unit
	Timing accuracy (monostable) ⁽¹⁾ R = 10 kΩ, C = 0.1 μF	—	2	—	%
	Timing shift with supply voltage variations (monostable) ⁽¹⁾ R = 10 kΩ, C = 0.1 μF, V _{CC} = 5 V ± 1 V		0.38		%/V
	Timing shift with temperature ⁽¹⁾ T _{min} ≤ T _{amb} ≤ T _{max} ⁵		75		ppm/°C
f _{max}	Maximum astable frequency ⁽²⁾ R _A = 470 Ω, R _B = 200 Ω, C = 200 pF		2.7		MHz
	Astable frequency accuracy ⁽²⁾ R _A = R _B = 1 kΩ to 100 kΩ, C = 0.1 μF		3		%
	Timing shift with supply voltage variations (astable mode) ⁽²⁾ R _A = R _B = 10 kΩ, C = 0.1 μF, V _{CC} = 5 to 12 V		0.1		%/V
t _R	Output rise time (C _{load} = 10 pF)		25		ns
t _F	Output fall time (C _{load} = 10 pF)		20		
t _{PD}	Trigger propagation delay		100		
t _{RPW}	Minimum reset pulse width (V _{trig} = 5 V)		350		

1. See [Figure 4](#)
2. See [Figure 6](#)

Table 9. Static electrical characteristics
 $V_{CC} = +12\text{ V}$, $T_{amb} = +25\text{ °C}$, reset to V_{CC} (unless otherwise specified)

Symbol	Parameter	Min.	Typ.	Max.	Unit
I_{CC}	Supply current (no load, high and low states) $T_{min} \leq T_{amb} \leq T_{max}$		170	400 400	μA
V_{CL}	Control voltage level $T_{min} \leq T_{amb} \leq T_{max}$	7.4 7.3	8	8.6 8.7	V
V_{DIS}	Discharge saturation voltage ($I_{dis} = 80\text{ mA}$) $T_{min} \leq T_{amb} \leq T_{max}$		0.09	1.5 2.0	
I_{DIS}	Discharge pin leakage current		1	100	nA
V_{OL}	Low level output voltage ($I_{sink} = 50\text{ mA}$) $T_{min} \leq T_{amb} \leq T_{max}$		1.2	2 2.8	V
V_{OH}	High level output voltage ($I_{source} = -10\text{ mA}$) $T_{min} \leq T_{amb} \leq T_{max}$	10.5 10.5	11		
V_{TRIG}	Trigger voltage $T_{min} \leq T_{amb} \leq T_{max}$	3.2 3.1	4	4.8 4.9	
I_{TRIG}	Trigger current		10		pA
I_{TH}	Threshold current		10		
V_{RESET}	Reset Voltage $T_{min} \leq T_{amb} \leq T_{max}$	0.4 0.3	1.1	1.5 2.0	V
I_{RESET}	Reset current		10		pA

Table 10. Dynamic electrical characteristics
 $V_{CC} = +12\text{ V}$, $T_{amb} = +25\text{ }^\circ\text{C}$, reset to V_{CC} (unless otherwise specified)

Symbol	Parameter	Min.	Typ.	Max.	Unit
	Timing accuracy (monostable) ⁽¹⁾ R = 10 kΩ, C = 0.1 μF, V _{CC} = +12 V	—	4	—	%
	Timing shift with supply voltage variations (monostable) ⁽¹⁾ R = 10 kΩ, C = 0.1 μF, V _{CC} = +5 V ±1 V		0.38		%/V
	Timing shift with temperature T _{min} ≤ T _{amb} ≤ T _{max} , V _{CC} = +5 V		75		ppm/°C
f _{max}	Maximum astable frequency ⁽²⁾ R _A = 470 Ω, R _B = 200 Ω, C = 200 pF, V _{CC} = +5 V		2.7		MHz
	Astable frequency accuracy R _A = R _B = 1 kΩ to 100 kΩ, C = 0.1 μF, V _{CC} = +12 V		3		%
	Timing shift with supply voltage variations (astable mode) R _A = R _B = 1 kΩ to 100 kΩ, C = 0.1 μF, V _{CC} = 5 to +12 V		0.1		%/V

1. See [Figure 4](#)
2. See [Figure 6](#)

Figure 3. Supply current (per timer) versus supply voltage

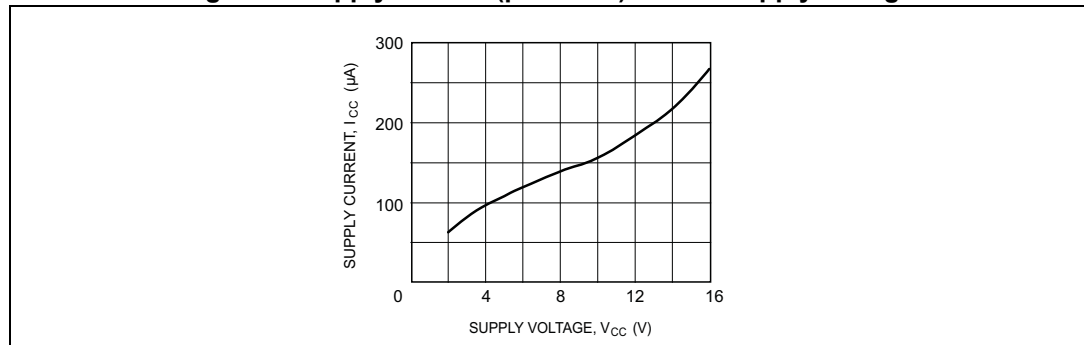

4 Application information

4.1 Monostable operation

In monostable mode, the timer operates like a one-shot generator. The external capacitor is initially held discharged by a transistor inside the timer, as shown in *Figure 4*.

Figure 4. Application schematic

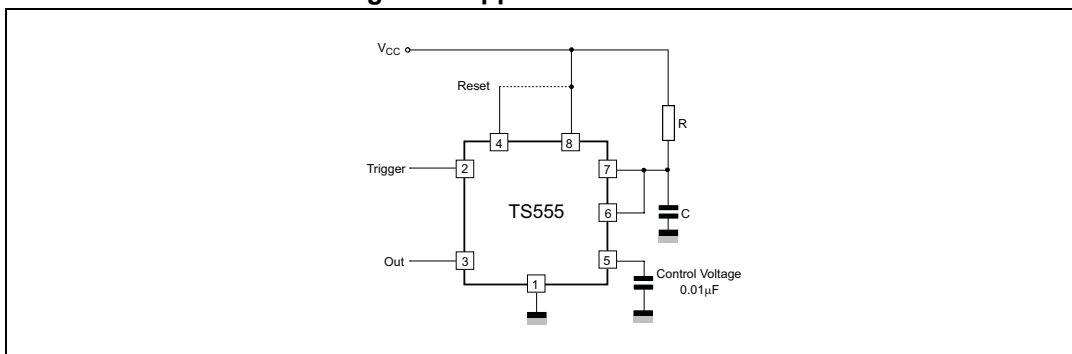

The circuit triggers on a negative-going input signal when the level reaches $1/3 V_{CC}$. Once triggered, the circuit remains in this state until the set time has elapsed, even if it is triggered again during this interval. The duration of the output HIGH state is given by $t = 1.1 R \times C$.

Since the charge rate and threshold level of the comparator are both directly proportional to the supply voltage, the timing interval is independent of the supply. Applying a negative pulse simultaneously to the reset terminal (pin 4) and the trigger terminal (pin 2) during the timing cycle discharges the external capacitor and causes the cycle to start over. The timing cycle then starts on the positive edge of the reset pulse. While the reset pulse is applied, the output is driven to the LOW state.

When a negative trigger pulse is applied to pin 2, the flip-flop is set, releasing the short circuit across the external capacitor and driving the output HIGH. The voltage across the capacitor increases exponentially with the time constant $\tau = R \times C$.

When the voltage across the capacitor equals $2/3 V_{CC}$, the comparator resets the flip-flop which then discharges the capacitor rapidly and drives the output to its LOW state. *Figure 5* shows the actual waveforms generated in this mode of operation.

When reset is not used, it should be tied high to avoid any false triggering.

Figure 5. Timing diagram

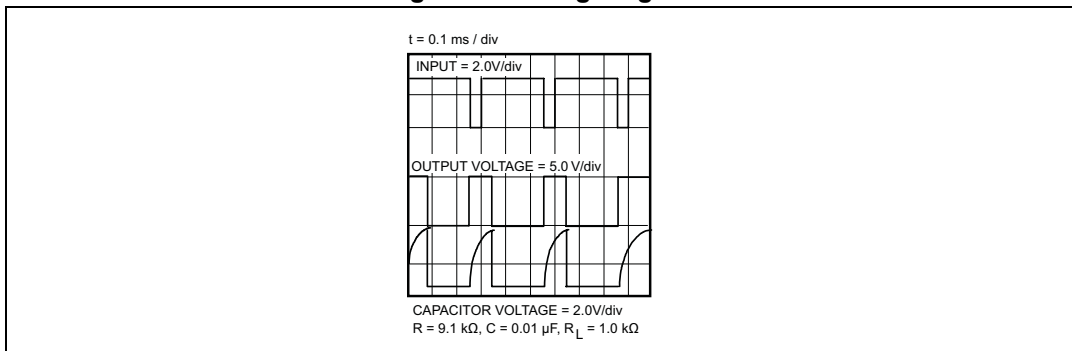

4.2 Astable operation

When the circuit is connected as shown in *Figure 6* (pins 2 and 6 connected) it triggers itself and runs as a multi-vibrator. The external capacitor charges through R_A and R_B and discharges through R_B only. Therefore, the duty cycle may be precisely set by the ratio of these two resistors.

In the astable mode of operation, C charges and discharges between $1/3 V_{CC}$ and $2/3 V_{CC}$. As in the triggered mode, the charge and discharge times, and therefore frequency, are independent of the supply voltage.

Figure 6. Application schematic

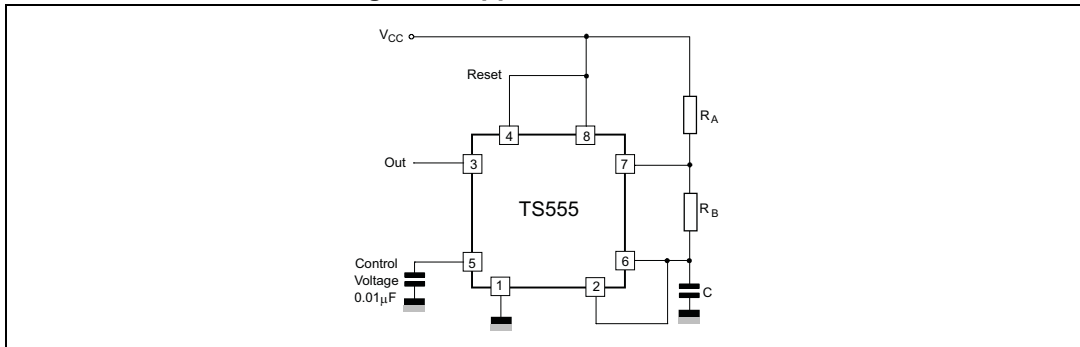

Figure 7 shows actual waveforms generated in this mode of operation.

The charge time (output HIGH) is given by:

$$t1 = 0.693 (R_A + R_B) C$$

The discharge time (output LOW) by:

$$t2 = 0.693 \times R_B \times C$$

Thus the total period T is given by:

$$T = t1 + t2 = 0.693 (R_A + 2R_B) C$$

The frequency of oscillation is then:

$$f = \frac{1}{T} = \frac{1.44}{(R_A + 2R_B)C}$$

The duty cycle is given by:

$$D = \frac{R_B}{R_A + 2R_B}$$

Figure 7. Timing diagram

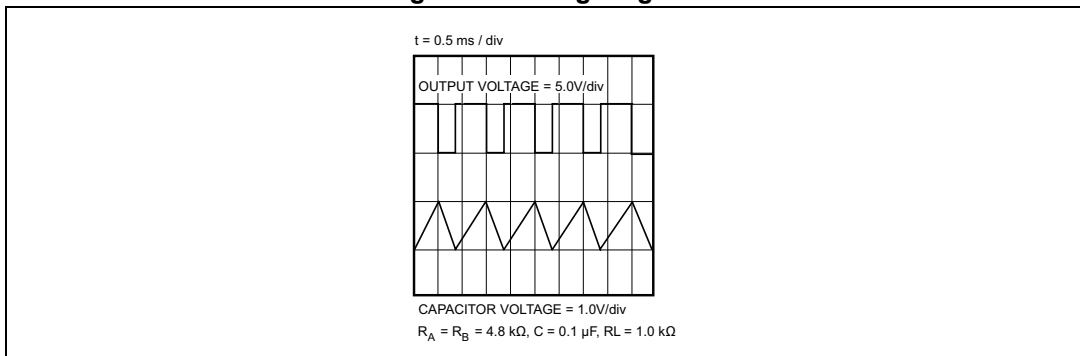

5 Package information

In order to meet environmental requirements, ST offers these devices in different grades of ECOPACK packages, depending on their level of environmental compliance. ECOPACK specifications, grade definitions and product status are available at: www.st.com. ECOPACK is an ST trademark.

5.1 SO8 package information

Figure 8. SO8 package outline

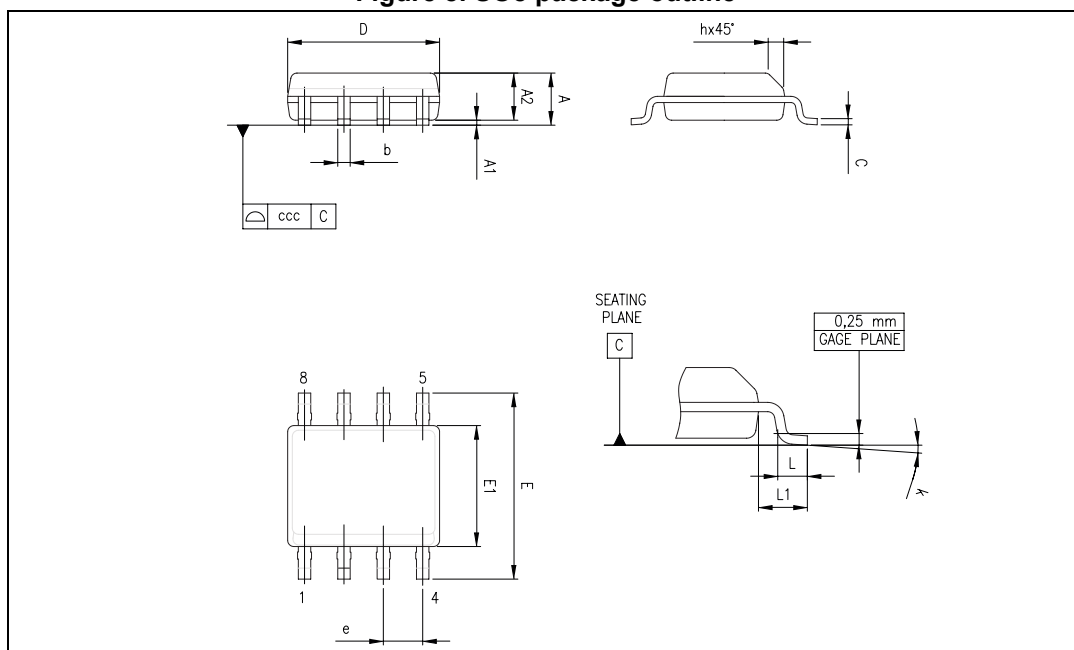

Table 11. SO8 mechanical data

Ref.	Dimensions					
	Millimeters			Inches		
	Min.	Typ.	Max.	Min.	Typ.	Max.
A			1.75			0.069
A1	0.10		0.25	0.004		0.010
A2	1.25			0.049		
b	0.28		0.48	0.011		0.019
c	0.17		0.23	0.007		0.010
D	4.80	4.90	5.00	0.189	0.193	0.197
E	5.80	6.00	6.20	0.228	0.236	0.244
E1	3.80	3.90	4.00	0.150	0.154	0.157
e		1.27			0.050	
h	0.25		0.50	0.010		0.020
L	0.40		1.27	0.016		0.050
L1		1.04			0.040	
k	1°		8°	1°		8°
ccc			0.10			0.004

6 Ordering information

Table 12. Order code table

Order code	Temperature range	Package	Packaging	Marking
TS555IDTTR	-40 °C to 125 °C	SO8	Tape and reel	555I

7 Revision history

Table 13. Document revision history

Date	Revision	Changes
01-Feb-2003	1	Initial release.
03-Nov-2008	2	Document reformatted. Added output current, ESD and thermal resistance values in Table 1: Absolute maximum ratings. Added output current values in Table 2: Operating conditions.
29-Aug-2014	3	Section 5: Package information: updated corporate text Replaced Table 15: Ordering information scheme.
24-Jun-2015	4	Features and Description: added footnote to NE555 product to explain it is terminated. Removed all references to DIP8 and TSSOP8 packages Removed all temperature ranges except -40 to 125 °C Replaced Table 15: Ordering information scheme with Table 12: Order code table.
13-Jan-2025	5	Updated I _{OUT} value in Table 2.
01-Apr-2026	6	Updated Figure 1 , Figure 2 , Figure 3 , Figure 4 , Figure 5 , Figure 6 and Figure 7 .

IMPORTANT NOTICE – PLEASE READ CAREFULLY

STMicroelectronics NV and its subsidiaries ("ST") reserve the right to make changes, corrections, enhancements, modifications, and improvements to ST products and/or to this document at any time without notice.

In the event of any conflict between the provisions of this document and the provisions of any contractual arrangement in force between the purchasers and ST, the provisions of such contractual arrangement shall prevail.

The purchasers should obtain the latest relevant information on ST products before placing orders. ST products are sold pursuant to ST's terms and conditions of sale in place at the time of order acknowledgment.

The purchasers are solely responsible for the choice, selection, and use of ST products and ST assumes no liability for application assistance or the design of the purchasers' products.

No license, express or implied, to any intellectual property right is granted by ST herein.

Resale of ST products with provisions different from the information set forth herein shall void any warranty granted by ST for such product.

If the purchasers identify an ST product that meets their functional and performance requirements but that is not designated for the purchasers' market segment, the purchasers shall contact ST for more information.

ST and the ST logo are trademarks of ST. For additional information about ST trademarks, please refer to www.st.com/trademarks. All other product or service names are the property of their respective owners.

Information in this document supersedes and replaces information previously supplied in any prior versions of this document.

© 2026 STMicroelectronics – All rights reserved