

EMIF04-VID01C2

Table 2: Absolute Ratings (limiting values)

Symbol	Parameter and test conditions	Value	Unit
T_j	Maximum junction temperature	125	°C
T_{op}	Operating temperature range	- 40 to + 85	°C
T_{stg}	Storage temperature range	- 55 to + 150	°C

Table 3: Electrical Characteristics ($T_{amb} = 25^\circ\text{C}$)

Symbol	Parameter
V_{BR}	Breakdown voltage
I_{RM}	Leakage current @ V_{RM}
V_{RM}	Stand-off voltage
R	Series resistance between Input & Output
C_{line}	Input capacitance per line

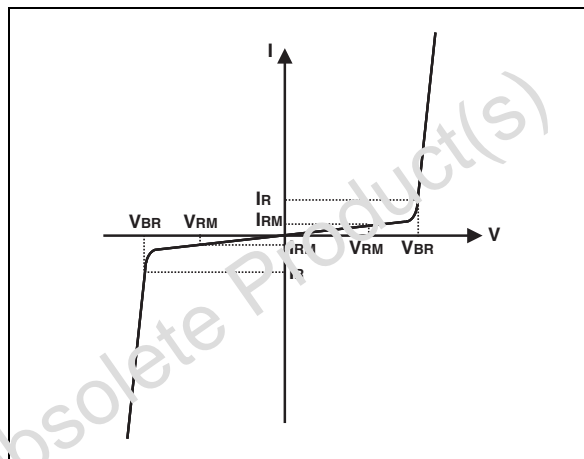

Symbol	Test conditions	Min.	Typ.	Max.	Unit
V_{BR}	$I_R = 1\text{mA}$	6	8	10	V
I_{RM}	$V_{RM} = 3\text{V}$ per line			500	nA
R	$i = 10\text{mA}$	80	100	120	Ω
C_{line}	$V_R = 3\text{V DC}$ 1MHz $V_{OSC} = 30\text{mV}$		16	19	pF

Figure 3: S21 (dB) attenuation measurement

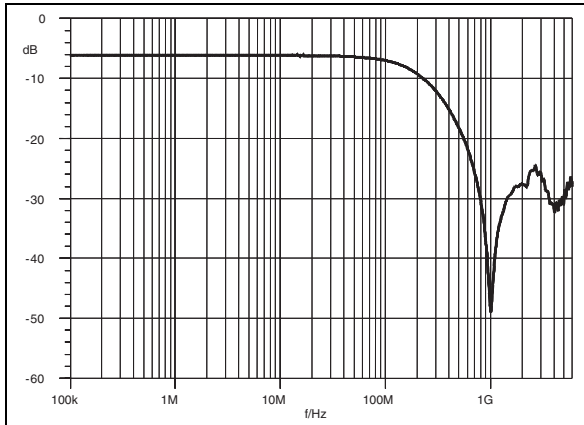

Figure 4: Analog crosstalk measurement

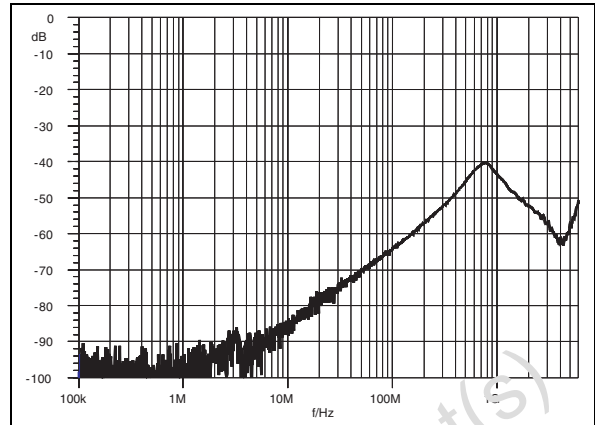

Figure 5: ESD response to IEC61000-4-2 (+15kV air discharge) on one input V(in) and on one output (Vout)

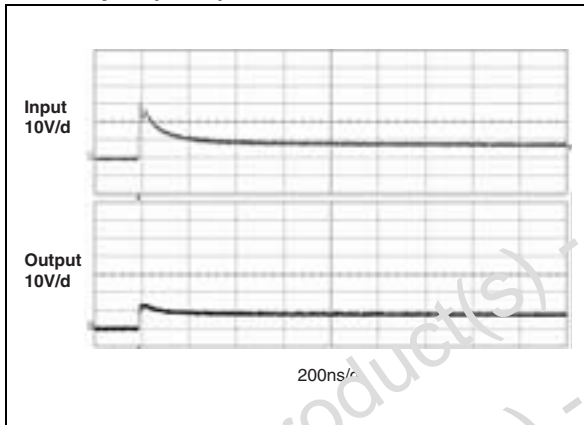

Figure 6: ESD response to IEC61000-4-2 (-15kV air discharge) on one input V(in) and on one output (Vout)

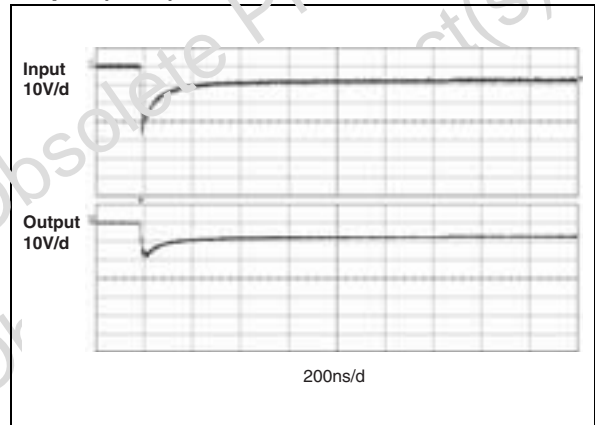

Figure 7: Junction capacitance versus reverse voltage applied (typical values)

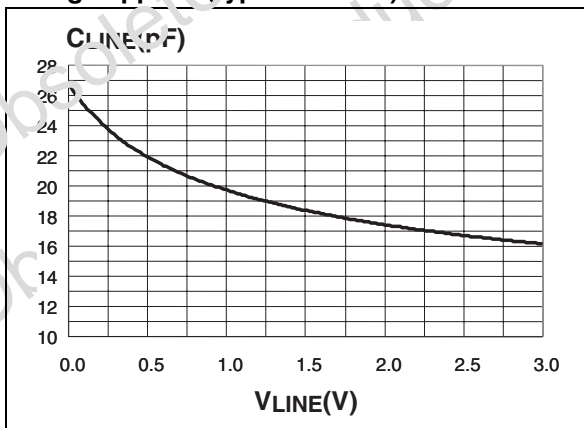

Figure 8: Ordering Information Scheme

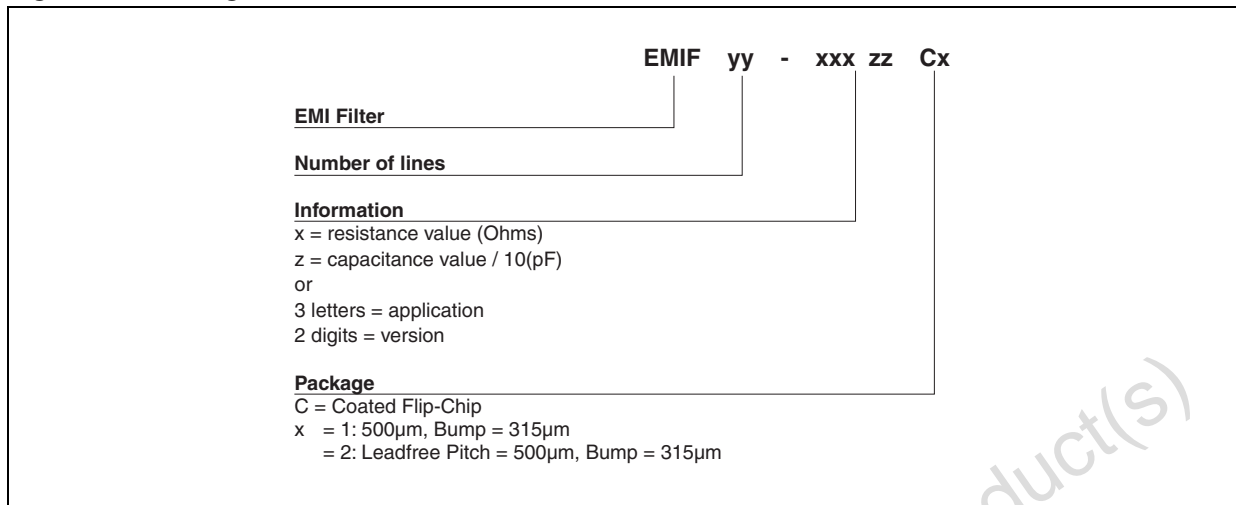

Figure 9: FLIP-CHIP Package Mechanical Data

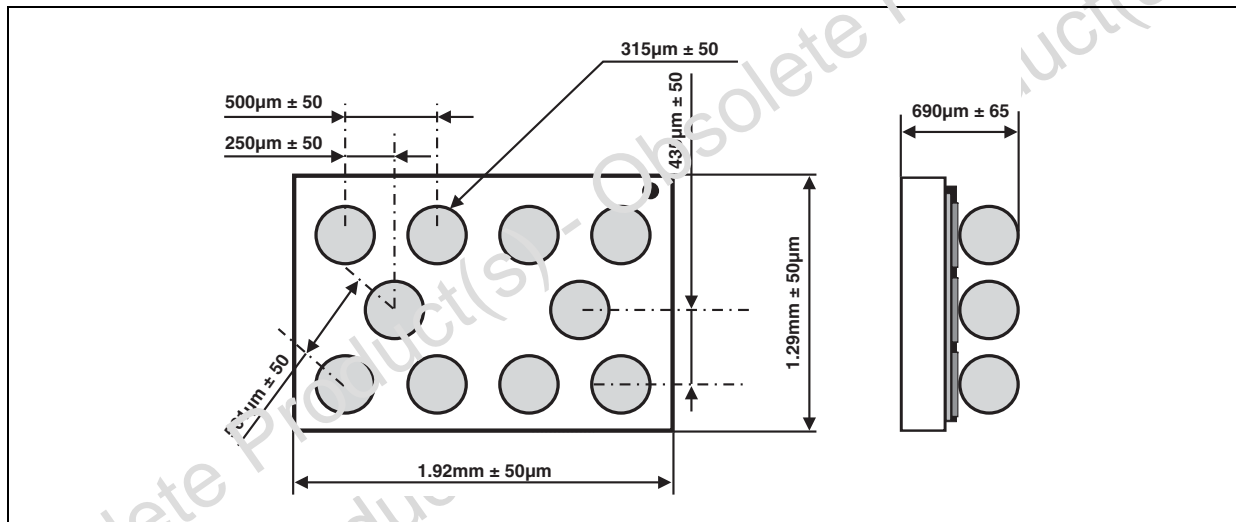

Figure 10: Foot Print Recommendations

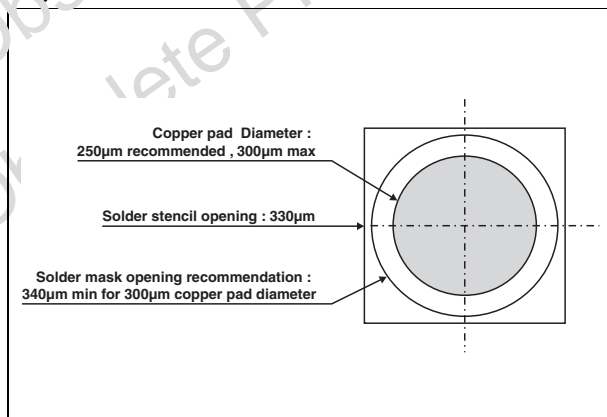

Figure 11: Marking

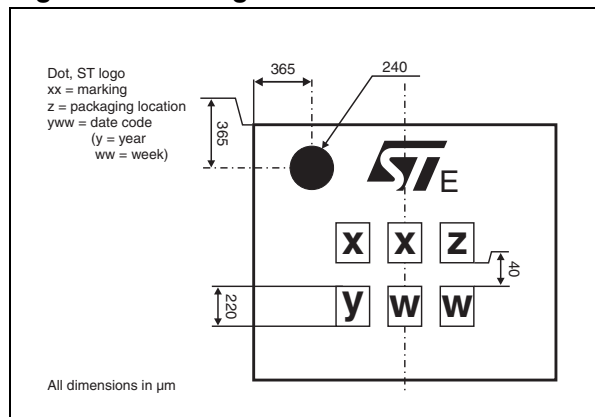
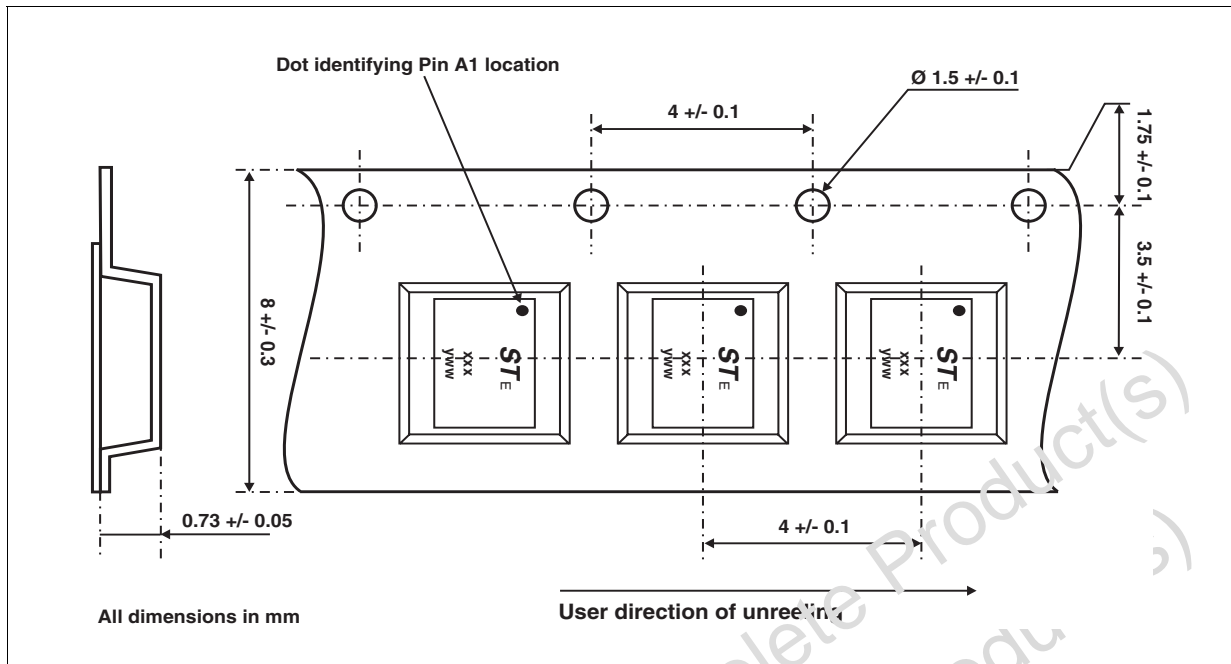

Figure 12: FLIP-CHIP Tape and Reel Specification



In order to meet environmental requirements, ST offers these devices in ECOPACK® packages. These packages have a Lead-free second level interconnect. The category of second level interconnect is marked on the package and on the inner box label, in compliance with JEDEC Standard JESD97. The maximum ratings related to soldering conditions are also marked on the inner box label. ECOPACK is an ST trademark. ECOPACK specifications are available at: www.st.com.

Table 4: Ordering Information

Ordering code	Marking	Package	Weight	Base qty	Delivery mode
EMIF04-VID01C2	GU	Flip-Chip	3.9 mg	5000	Tape & reel 7"

Note: More packing informations are available in the application note
 AN1235: "Flip-Chip: Package description and recommendations for use"
 AN1751: "EMI Filters: Recommendations and measurements"

Table 5: Revision History

Date	Revision	Description of Changes
12-Aug-2005	1	First issue.

Information furnished is believed to be accurate and reliable. However, STMicroelectronics assumes no responsibility for the consequences of use of such information nor for any infringement of patents or other rights of third parties which may result from its use. No license is granted by implication or otherwise under any patent or patent rights of STMicroelectronics. Specifications mentioned in this publication are subject to change without notice. This publication supersedes and replaces all information previously supplied. STMicroelectronics products are not authorized for use as critical components in life support devices or systems without express written approval of STMicroelectronics.

The ST logo is a registered trademark of STMicroelectronics.
All other names are the property of their respective owners

© 2005 STMicroelectronics - All rights reserved

STMicroelectronics group of companies

Australia - Belgium - Brazil - Canada - China - Czech Republic - Finland - France - Germany - Hong Kong - India - Israel - Italy - Japan -
Malaysia - Malta - Morocco - Singapore - Spain - Sweden - Switzerland - United Kingdom - United States of America
www.st.com