

## N-channel 500 V, 400 mΩ typ., 11 A SuperMESH Power MOSFET in a TO-220FP package

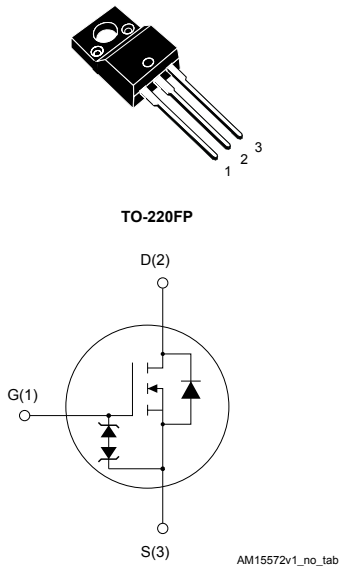

### Product status link

[STF13NK50Z](#)

### Product summary

<b>Order code</b>	STF13NK50Z
<b>Marking</b>	F13NK50Z
<b>Package</b>	TO-220FP
<b>Packing</b>	Tube

### Features

Order code	V <sub>DS</sub>	R <sub>DS(on)</sub> max.	I <sub>D</sub>
STF13NK50Z	500 V	480 mΩ	11 A

- 100% avalanche tested
- Extremely high dv/dt capability
- Gate charge minimized
- Zener-protected

### Applications

- Switching applications

### Description

This high-voltage device is a Zener-protected N-channel Power MOSFET developed using the SuperMESH technology by STMicroelectronics, an optimization of the well-established PowerMESH. In addition to a significant reduction in on-resistance, this device is designed to ensure a high level of dv/dt capability for the most demanding applications.

# 1 Electrical ratings

**Table 1. Absolute maximum ratings**

Symbol	Parameter	Value	Unit
$V_{DS}$	Drain-source voltage	500	V
$V_{GS}$	Gate-source voltage	±30	V
$I_D$	Drain current (continuous) at $T_C = 25\text{ °C}$	11	A
	Drain current (continuous) at $T_C = 100\text{ °C}$	6.93	
$I_{DM}^{(1)}$	Drain current (pulsed)	44	A
$P_{TOT}$	Total power dissipation at $T_C = 25\text{ °C}$	30	W
ESD	Gate-source human body model ( $R = 1.5\text{ k}\Omega$ , $C = 100\text{ pF}$ )	2.5	kV
$dv/dt^{(2)}$	Peak diode recovery voltage slope	4.5	V/ns
$V_{ISO}$	Insulation withstand voltage (RMS) from all three leads to external heat sink ( $t = 1\text{ s}$ ; $T_C = 25\text{ °C}$ )	2.5	kV
$T_{stg}$	Storage temperature range	-55 to 150	°C
$T_J$	Operating junction temperature range		

1. Pulse width is limited by safe operating area.
2.  $I_{SD} \leq 11\text{ A}$ ,  $di/dt \leq 200\text{ A}/\mu\text{s}$ ,  $V_{DD} = 400\text{ V}$ .

**Table 2. Thermal data**

Symbol	Parameter	Value	Unit
$R_{thJC}$	Thermal resistance, junction-to-case	4.17	°C/W
$R_{thJA}$	Thermal resistance, junction-to-ambient	62.5	°C/W

**Table 3. Avalanche characteristics**

Symbol	Parameter	Value	Unit
$I_{AR}$	Avalanche current, repetitive or not-repetitive (pulse width limited by $T_J$ max.)	11	A
$E_{AS}$	Single pulse avalanche energy (starting $T_J = 25\text{ °C}$ , $I_D = I_{AR}$ , $V_{DD} = 50\text{ V}$ )	240	mJ

## 2 Electrical characteristics

$T_C = 25\text{ °C}$  unless otherwise specified.

**Table 4. On/off states**

Symbol	Parameter	Test conditions	Min.	Typ.	Max.	Unit
$V_{(BR)DSS}$	Drain-source breakdown voltage	$I_D = 1\text{ mA}$ , $V_{GS} = 0\text{ V}$	500	-	-	V
$I_{DSS}$	Zero gate voltage drain current	$V_{GS} = 0\text{ V}$ , $V_{DS} = 500\text{ V}$	-	-	1	$\mu\text{A}$
		$V_{GS} = 0\text{ V}$ , $V_{DS} = 500\text{ V}$ , $T_C = 125\text{ °C}^{(1)}$	-	-	50	
$I_{GSS}$	Gate body leakage current	$V_{GS} = \pm 20\text{ V}$ , $V_{DS} = 0\text{ V}$	-	-	$\pm 10$	$\mu\text{A}$
$V_{GS(th)}$	Gate threshold voltage	$V_{DS} = V_{GS}$ , $I_D = 100\text{ }\mu\text{A}$	3	3.75	4.5	V
$R_{DS(on)}$	Static drain-source on-resistance	$V_{GS} = 10\text{ V}$ , $I_D = 6.5\text{ A}$	-	400	480	m $\Omega$

1. Specified by design, not tested in production.

**Table 5. Dynamic**

Symbol	Parameter	Test conditions	Min.	Typ.	Max.	Unit
$C_{iss}$	Input capacitance	$V_{DS} = 25\text{ V}$ , $f = 1\text{ MHz}$ , $V_{GS} = 0\text{ V}$	-	1600	-	pF
$C_{oss}$	Output capacitance		-	200	-	pF
$C_{rss}$	Reverse transfer capacitance		-	45	-	pF
$C_{oss\text{ eq.}}^{(1)}$	Equivalent output capacitance	$V_{GS} = 0\text{ V}$ , $V_{DS} = 0\text{ to }400\text{ V}$	-	50	-	pF
$Q_g$	Total gate charge	$V_{DD} = 400\text{ V}$ , $I_D = 13\text{ A}$ , $V_{GS} = 0\text{ to }10\text{ V}$ (see the Figure 14. Test circuit for gate charge behavior)	-	47	-	nC
$Q_{gs}$	Gate-source charge		-	9	-	nC
$Q_{gd}$	Gate-drain charge		-	28	-	nC
$R_g$	Intrinsic gate resistance		$f = 1\text{ MHz}$ , $I_D = 0\text{ A}$	-	2.3	-

1.  $C_{oss\text{ eq.}}$  is defined as a constant equivalent capacitance giving the same charging time as  $C_{oss}$  when  $V_{DS}$  increases from 0 to 80%  $V_{DSS}$ .

**Table 6. Switching times**

Symbol	Parameter	Test condition	Min.	Typ.	Max.	Unit
$t_{d(on)}$	Turn-on delay time	$V_{DD} = 400\text{ V}$ , $I_D = 6.5\text{ A}$ , $R_G = 4.7\text{ }\Omega$ , $V_{GS} = 10\text{ V}$	-	18	-	ns
$t_r$	Rise time		-	23	-	ns
$t_{d(off)}$	Turn-off delay time	(see the Figure 13. Test circuit for resistive load switching times and Figure 18. Switching time waveform)	-	61	-	ns
$t_f$	Fall time		-	24	-	ns

**Table 7. Source-drain diode**

Symbol	Parameter	Test conditions	Min.	Typ.	Max.	Unit
$I_{SD}$	Source-drain current		-	-	11	A
$I_{SDM}^{(1)}$	Source-drain current (pulsed)		-	-	44	A
$V_{SD}^{(2)}$	Forward on voltage	$I_{SD} = 11\text{ A}$ , $V_{GS} = 0\text{ V}$	-	-	1.6	V
$t_{rr}$	Reverse recovery time	$I_{SD} = 6.5\text{ A}$ , $di/dt = 100\text{ A}/\mu\text{s}$ ,	-	380	-	ns
$Q_{rr}$	Reverse recovery charge	$V_{DD} = 40\text{ V}$	-	3.4	-	$\mu\text{C}$
$I_{RRM}$	Reverse recovery current	(see the Figure 15. Test circuit for inductive load switching and diode recovery times)	-	18	-	A
$t_{rr}$	Reverse recovery time	$I_{SD} = 6.5\text{ A}$ , $di/dt = 100\text{ A}/\mu\text{s}$ ,	-	425	-	ns
$Q_{rr}$	Reverse recovery charge	$V_{DD} = 40\text{ V}$ , $T_J = 150\text{ }^\circ\text{C}$	-	3.9	-	$\mu\text{C}$
$I_{RRM}$	Reverse recovery current	(see the Figure 15. Test circuit for inductive load switching and diode recovery times)	-	18.5	-	A

1. Pulse width is limited by safe operating area.
2. Pulsed: pulse duration = 300  $\mu\text{s}$ , duty cycle 1.5%.

## 2.1 Electrical characteristics (curves)

Figure 1. Safe operating area

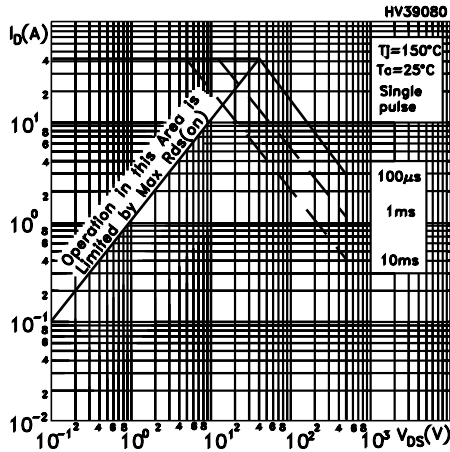

Figure 2. Normalized transient thermal impedance

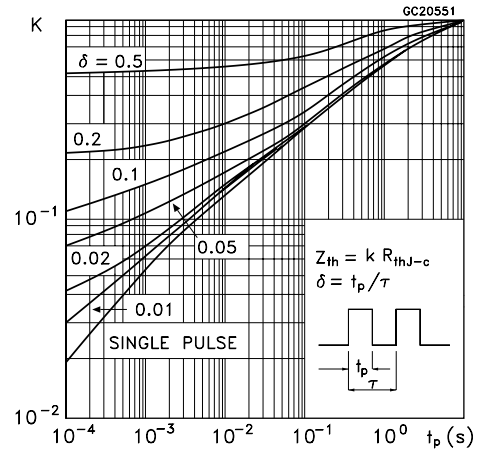

Figure 3. Typical output characteristics

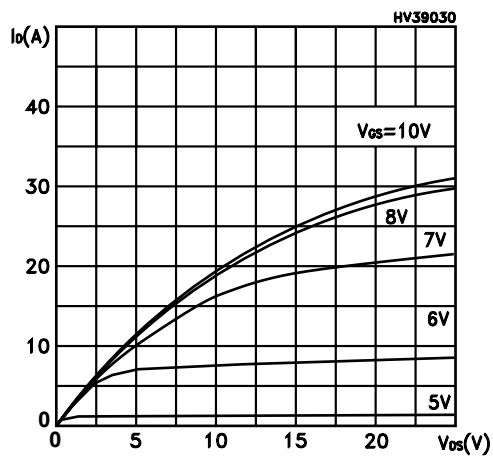

Figure 4. Typical transfer characteristics

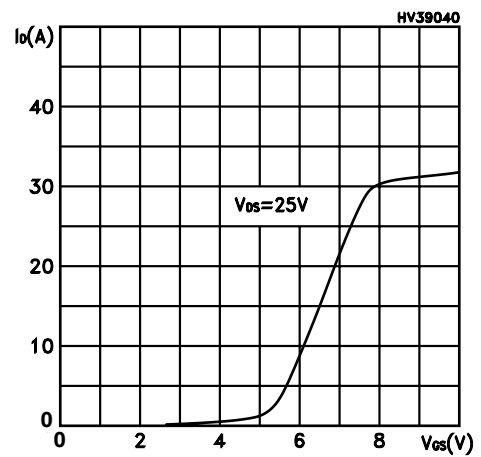

Figure 5. Typical gate charge characteristics

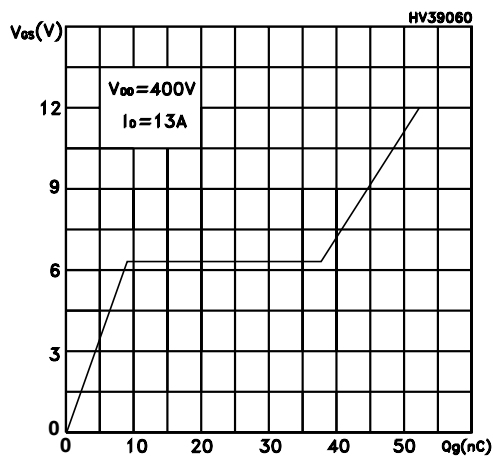

Figure 6. Typical drain-source on-resistance

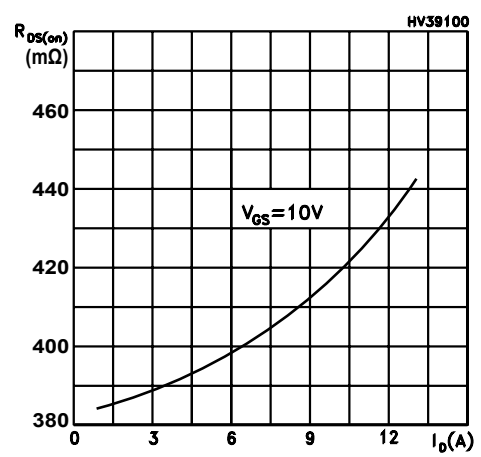

Figure 7. Typical capacitance characteristics

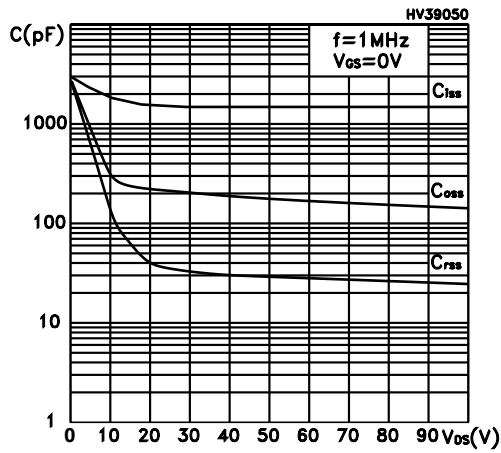

Figure 8. Normalized gate threshold vs temperature

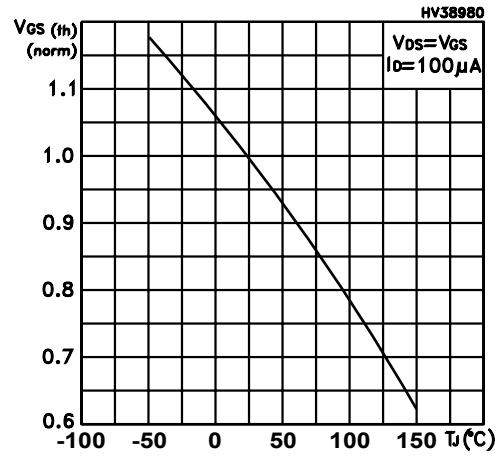

Figure 9. Normalized on-resistance vs temperature

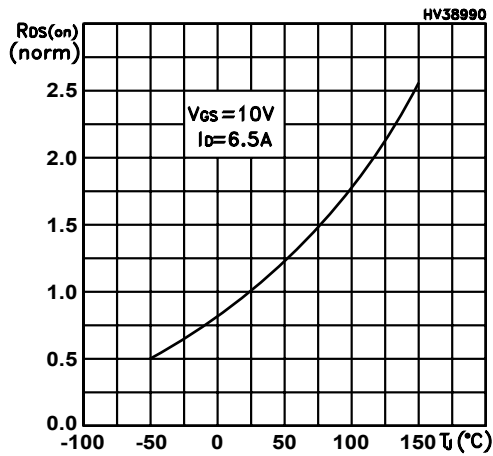

Figure 10. Normalized breakdown voltage vs temperature

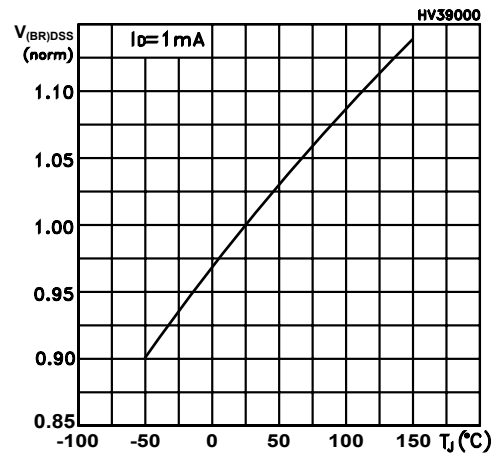

Figure 11. Maximum avalanche energy vs temperature

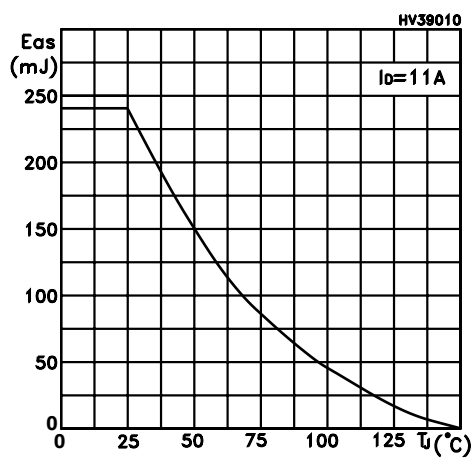
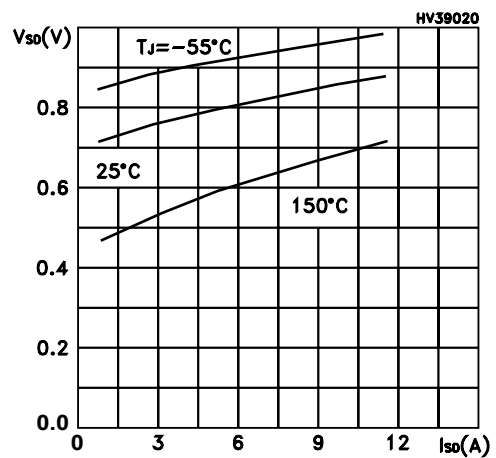

Figure 12. Typical reverse diode forward characteristics



### 3 Test circuits

**Figure 13. Test circuit for resistive load switching times**

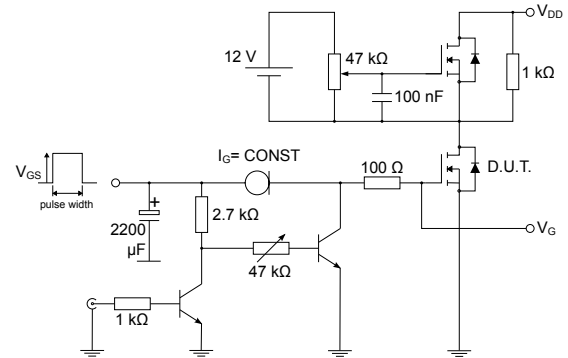

AM01468v1

**Figure 14. Test circuit for gate charge behavior**

AM01469v1

**Figure 15. Test circuit for inductive load switching and diode recovery times**

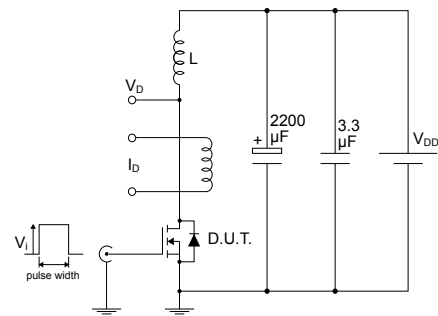
AM01470v1

**Figure 16. Unclamped inductive load test circuit**

AM01471v1

**Figure 17. Unclamped inductive waveform**

AM01472v1

**Figure 18. Switching time waveform**



AM01473v1

## 4 Package information

To meet environmental requirements, ST offers these devices in different grades of **ECOPACK** packages, depending on their level of environmental compliance. ECOPACK specifications, grade definitions, and product status are available at: [www.st.com](http://www.st.com). ECOPACK is an ST trademark.

### 4.1 TO-220FP type B package information

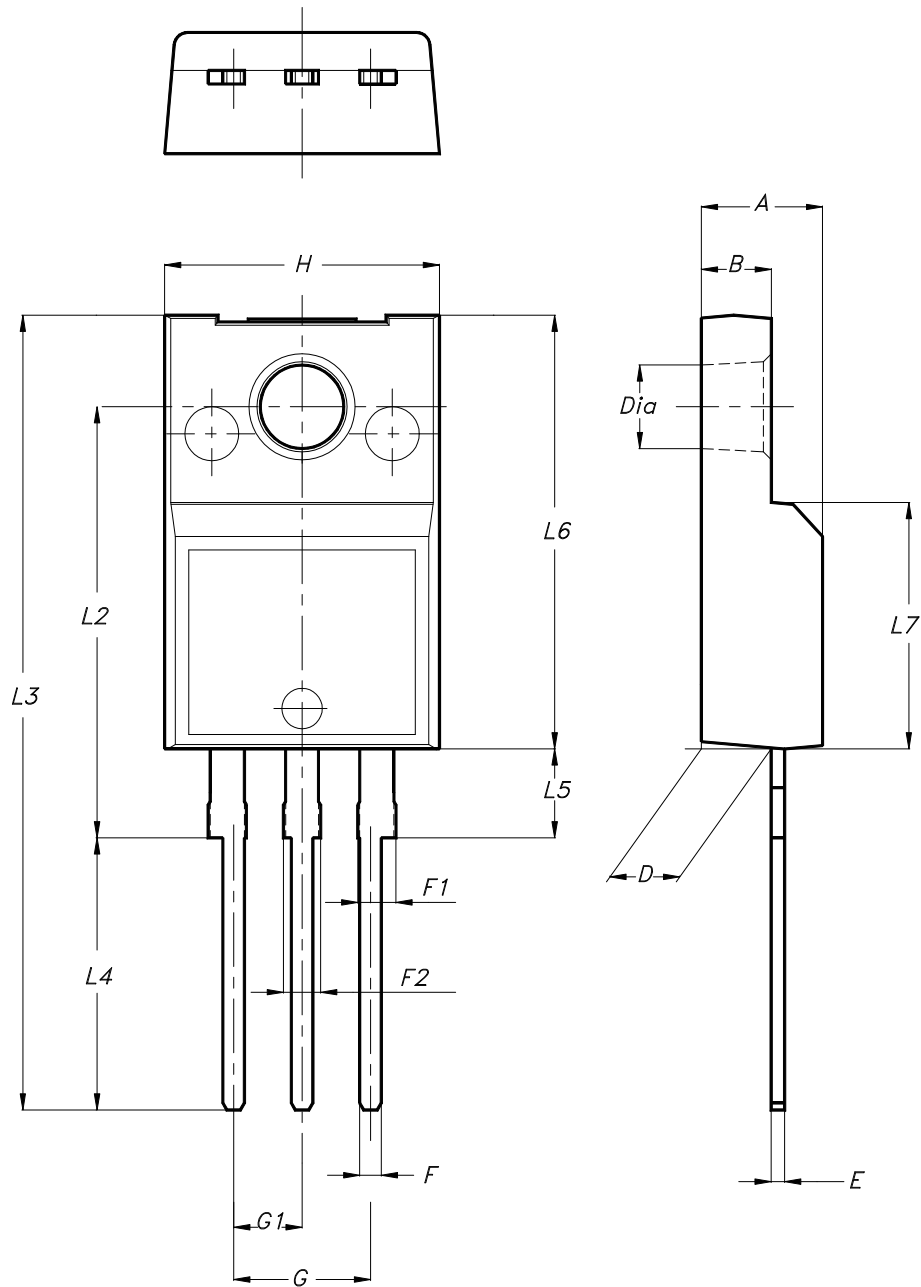
Figure 19. TO-220FP type B package outline



7012510\_B\_rev.14

**Table 8. TO-220FP type B package mechanical data**

Dim.	mm		
	Min.	Typ.	Max.
A	4.40		4.60
B	2.50		2.70
D	2.50		2.75
E	0.45		0.70
F	0.75		1.00
F1	1.15		1.70
F2	1.15		1.70
G	4.95		5.20
G1	2.40		2.70
H	10.00		10.40
L2		16.00	
L3	28.60		30.60
L4	9.80		10.60
L5	2.90		3.60
L6	15.90		16.40
L7	9.00		9.30
Dia	3.00		3.20

## Revision history

**Table 9. Document revision history**

Date	Revision	Changes
07-Aug-2007	1	First release.
19-Mar-2009	2	Update $I_D$ value test condition in <i>Table 6</i> .
06-Feb-2026	3	Removed order code STP13NK50Z and STW13NK50Z. Updated <a href="#">Section 4: Package information</a> . Minor text changes.

---

## Contents

<b>1</b>	<b>Electrical ratings</b> .....	<b>2</b>
<b>2</b>	<b>Electrical characteristics</b> .....	<b>3</b>
<b>2.1</b>	<b>Electrical characteristics (curves)</b> .....	<b>5</b>
<b>3</b>	<b>Test circuits</b> .....	<b>7</b>
<b>4</b>	<b>Package information</b> .....	<b>8</b>
<b>4.1</b>	<b>TO-220FP type B package information</b> .....	<b>8</b>
	<b>Revision history</b> .....	<b>10</b>

**IMPORTANT NOTICE – READ CAREFULLY**

STMicroelectronics NV and its subsidiaries (“ST”) reserve the right to make changes, corrections, enhancements, modifications, and improvements to ST products and/or to this document at any time without notice.

In the event of any conflict between the provisions of this document and the provisions of any contractual arrangement in force between the purchasers and ST, the provisions of such contractual arrangement shall prevail.

The purchasers should obtain the latest relevant information on ST products before placing orders. ST products are sold pursuant to ST’s terms and conditions of sale in place at the time of order acknowledgment.

The purchasers are solely responsible for the choice, selection, and use of ST products and ST assumes no liability for application assistance or the design of the purchasers’ products.

No license, express or implied, to any intellectual property right is granted by ST herein.

Resale of ST products with provisions different from the information set forth herein shall void any warranty granted by ST for such product.

If the purchasers identify an ST product that meets their functional and performance requirements but that is not designated for the purchasers’ market segment, the purchasers shall contact ST for more information.

ST and the ST logo are trademarks of ST. For additional information about ST trademarks, refer to [www.st.com/trademarks](http://www.st.com/trademarks). All other product or service names are the property of their respective owners.

Information in this document supersedes and replaces information previously supplied in any prior versions of this document.

© 2026 STMicroelectronics – All rights reserved