

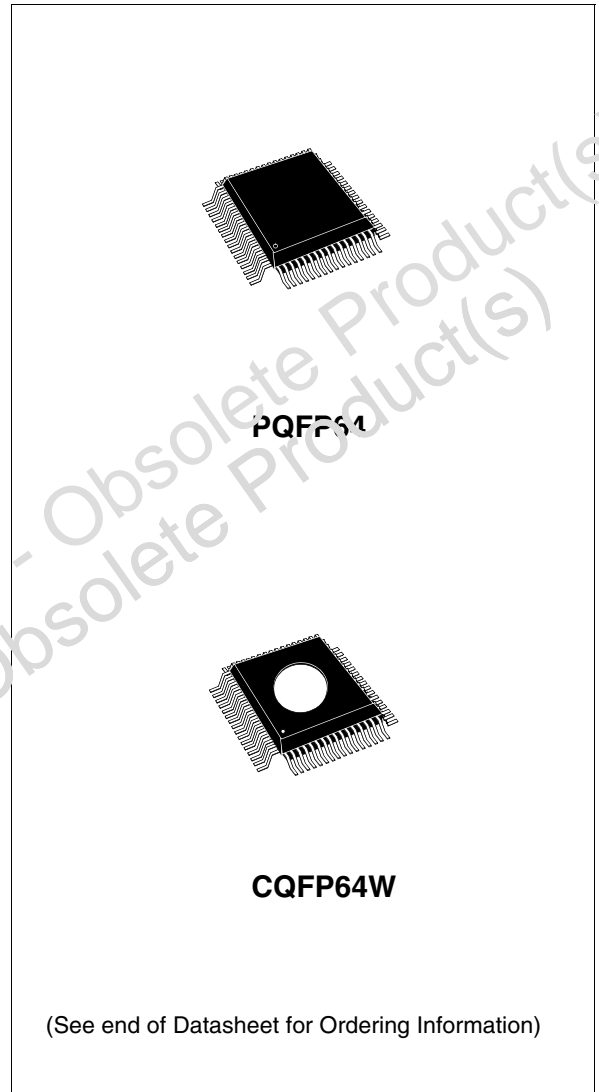

# ST62T42B/E42B

## 8-BIT OTP/EPROM MCU WITH LCD DRIVER, EEPROM AND A/D CONVERTER

- 3.0 to 6.0V Supply Operating Range
- 8 MHz Maximum Clock Frequency
- -40 to +85°C Operating Temperature Range
- Run, Wait and Stop Modes
- 5 Interrupt Vectors
- Look-up Table capability in Program Memory
- Data Storage in Program Memory:  
User selectable size
- Data RAM: 192 bytes
- Data EEPROM: 128 bytes
- User Programmable Options
- 18 I/O pins, fully programmable as:
  - Input with pull-up resistor
  - Input without pull-up resistor
  - Input with interrupt generation
  - Open-drain or push-pull output
  - Analog Input
  - LCD segments (8 combiport lines)
- 4 I/O lines can sink up to 20mA to drive LEDs or TRIACs directly
- Two 8-bit Timer/Counter with 7-bit programmable prescaler
- Digital Watchdog
- 8-bit A/D Converter with 6 analog inputs
- 8-bit Synchronous Peripheral Interface (SPI)
- LCD driver with 40 segment outputs, 4 backplane outputs and selectable multiplexing ratio
- On-chip Clock oscillator can be driven by Quartz Crystal or Ceramic resonator
- One external Non-Maskable Interrupt
- ST6242-EMU2 Emulation and Development System (connects to an MS-DOS PC via a parallel port).



### DEVICE SUMMARY

DEVICE	OTP (Bytes)	EPROM (Bytes)	EEPROM (Bytes)	I/O Pins
ST62T42B	7948	-	128	10 to 18
ST62E42B		7948	128	10 to 18

# Table of Contents

	Document Page
<b>ST62T42B/E42B</b> .....	<b>1</b>
<b>1 GENERAL DESCRIPTION</b> .....	<b>4</b>
1.1 INTRODUCTION .....	4
1.2 PIN DESCRIPTIONS .....	6
1.3 MEMORY MAP .....	7
1.3.1 Introduction .....	7
1.3.2 Program Space .....	7
1.3.3 Data Space .....	9
1.3.4 Stack Space .....	9
1.3.5 Data Window Register (DWR) .....	10
1.3.6 Data RAM/EEPROM Bank Register (DRBR) .....	11
1.3.7 EEPROM Description .....	12
1.4 PROGRAMMING MODES .....	14
1.4.1 Option Byte .....	14
1.4.2 Program Memory .....	14
1.4.3 EEPROM Data Memory .....	14
1.4.4 EPROM Erasing .....	14
<b>2 CENTRAL PROCESSING UNIT</b> .....	<b>15</b>
2.1 INTRODUCTION .....	15
2.2 CPU REGISTERS .....	15
<b>3 CLOCKS, RESET, INTERRUPTS AND POWER SAVING MODES</b> .....	<b>17</b>
3.1 CLOCK SYSTEM .....	17
3.1.1 Main Oscillator .....	17
3.2 RESETS .....	18
3.2.1 RESET Input .....	18
3.2.2 Power-on Reset .....	18
3.2.3 Watchdog Reset .....	19
3.2.4 Application Notes .....	19
3.2.5 MCU Initialization Sequence .....	19
3.3 DIGITAL WATCHDOG .....	21
3.3.1 Digital Watchdog Register (DWDR) .....	23
3.3.2 Application Notes .....	23
3.4 INTERRUPTS .....	25
3.4.1 Interrupt request .....	25
3.4.2 Interrupt Procedure .....	26
3.4.3 Interrupt Option Register (IOR) .....	27
3.4.4 Interrupt Sources .....	27
3.5 POWER SAVING MODES .....	29
3.5.1 WAIT Mode .....	29
3.5.2 STOP Mode .....	29
3.5.3 Exit from WAIT and STOP Modes .....	30
<b>4 ON-CHIP PERIPHERALS</b> .....	<b>31</b>
4.1 I/O PORTS .....	31
4.1.1 Operating Modes .....	32
4.1.2 Safe I/O State Switching Sequence .....	33
4.1.3 LCD alternate functions (combiports) .....	35

# Table of Contents

	Document Page
4.1.4 SPI alternate functions	35
4.1.5 I/O Port Option Registers	36
4.1.6 I/O Port Data Direction Registers	36
4.1.7 I/O Port Data Registers	36
4.2 TIMER 1 & 2	37
4.2.1 TIMER 1 & 2 Operating Mode	39
4.2.2 Timer Interrupt	39
4.2.3 Application Notes	39
4.2.4 TIMER 1 Registers	40
4.2.5 TIMER 2 Registers	41
4.3 A/D CONVERTER (ADC)	42
4.3.1 Application Notes	42
4.4 SERIAL PERIPHERAL INTERFACE (SPI)	44
4.5 LCD CONTROLLER-DRIVER	46
4.5.1 Multiplexing ratio and frame frequency setting	47
4.5.2 Segment and common plates driving	47
4.5.3 LCD RAM	48
4.5.4 Stand by or STOP operation mode	49
4.5.5 LCD Mode Control Register (LCDCR)	49
<b>5 SOFTWARE</b>	<b>50</b>
5.1 ST6 ARCHITECTURE	50
5.2 ADDRESSING MODES	50
5.3 INSTRUCTION SET	51
<b>6 ELECTRICAL CHARACTERISTICS</b>	<b>56</b>
6.1 ABSOLUTE MAXIMUM RATINGS	56
6.2 RECOMMENDED OPERATING CONDITIONS	57
6.3 DC ELECTRICAL CHARACTERISTICS	58
6.4 AC ELECTRICAL CHARACTERISTICS	59
6.5 A/D CONVERTER CHARACTERISTICS	59
6.6 TIMER CHARACTERISTICS	60
6.7 SPI CHARACTERISTICS	60
6.8 LCD ELECTRICAL CHARACTERISTICS	60
6.9 PSS ELECTRICAL CHARACTERISTICS (WHEN AVAILABLE)	60
<b>7 GENERAL INFORMATION</b>	<b>61</b>
7.1 PACKAGE MECHANICAL DATA	61
7.2 <b>PACKAGE THERMAL CHARACTERISTIC</b>	<b>62</b>
7.3 ORDERING INFORMATION	62
7.4 IMPORTANT NOTE	62
<b>ST6242B</b>	<b>64</b>

# 1 GENERAL DESCRIPTION

## 1.1 INTRODUCTION

The ST62T42B and ST62E42B devices are low cost members of the ST62xx 8-bit HCMOS family of microcontrollers, which are targeted at low to medium complexity applications. All ST62xx devices are based on a building block approach: a

common core is surrounded by a number of on-chip peripherals.

The ST62E42B is the erasable EPROM version of the ST62T42B device, which may be used to emulate the ST62T42B device, as well as the respective ST6242B ROM devices.

Figure 1. Block Diagram

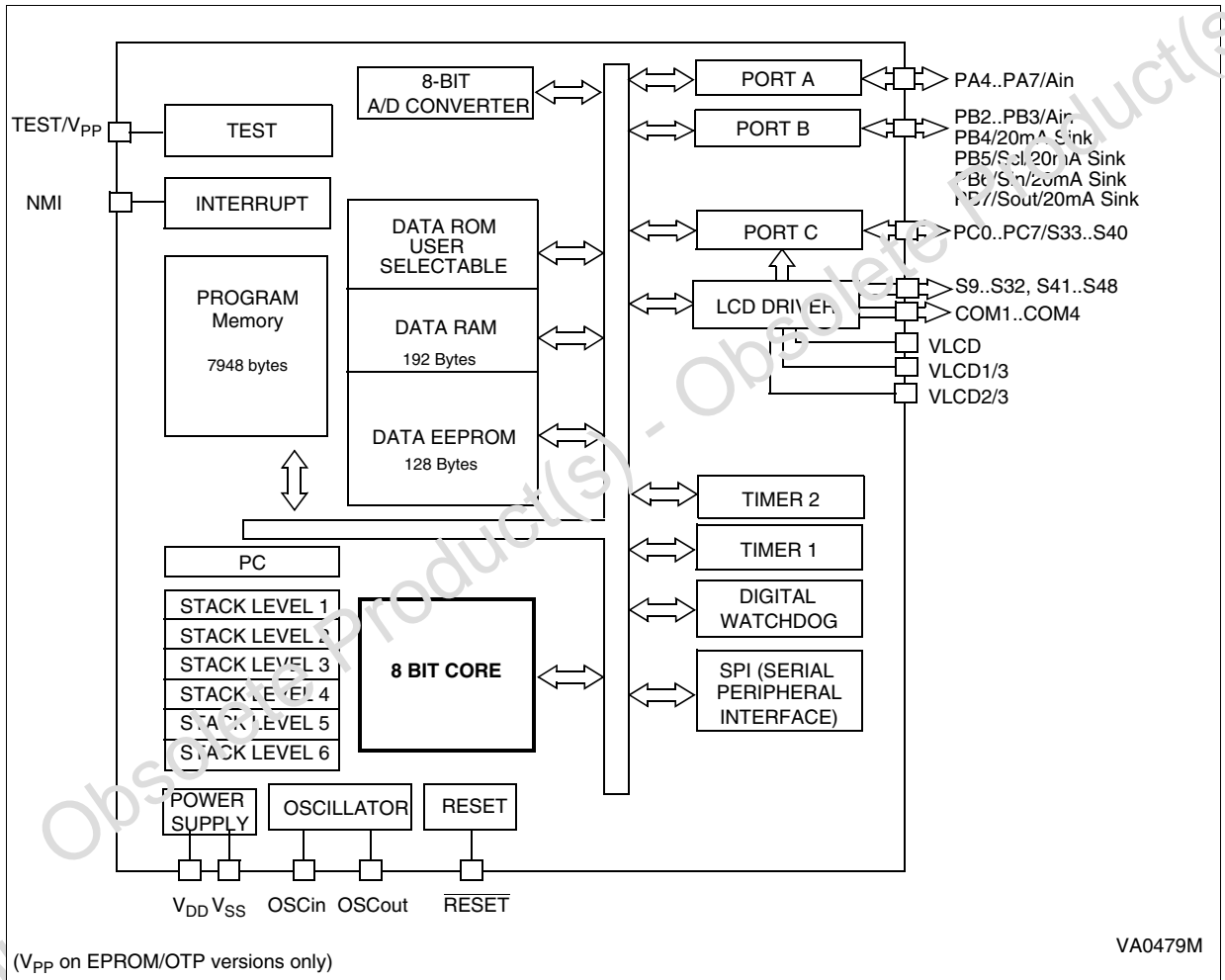

(V<sub>PP</sub> on EPROM/OTP versions only)

VA0479M

## INTRODUCTION (Cont'd)

OTP and EPROM devices are functionally identical. The ROM based versions offer the same functionality selecting as ROM options the options defined in the programmable option byte of the OTP/EPROM versions. OTP devices offer all the advantages of user programmability at low cost, which make them the ideal choice in a wide range of applications where frequent code changes, multiple code versions or last minute programmability are required.

These compact low-cost devices feature two Timers comprising an 8-bit counter and a 7-bit programmable prescaler, EEPROM data capability, a serial synchronous port interface (SPI), an 8-bit A/D Converter with 6 analog inputs, a Digital Watchdog timer, and a complete LCD controller driver, making them well suited for a wide range of automotive, appliance and industrial applications.

Figure 2. 64 Pin QFP Package

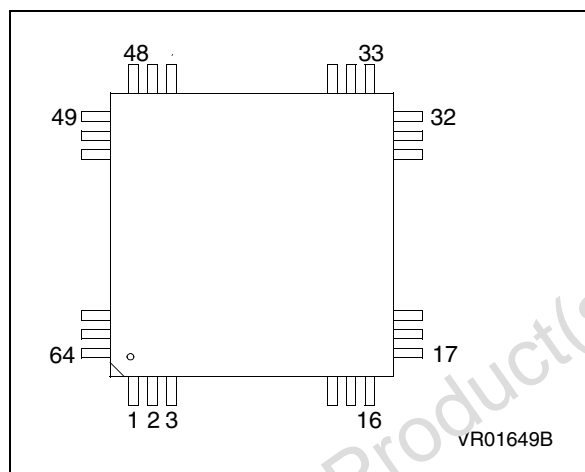

Table 1. ST6242 Pin Description

Pin number	Pin name	Pin number	Pin name	Pin number	Pin name	Pin number	Pin name
1	S45	17	VDD	33	S13	49	S29
2	S46	18	VSS	34	S14	50	S30
3	S47	19	RESET	35	S15	51	S31
4	S48	20	OSCCout	36	S16	52	S32
5	COM4	21	OSCCin	37	S17	53	PC0/S33
6	COM3	22	NMI	38	S18	54	PC1/S34
7	COM2	23	PB7/ Sout *	39	S19	55	PC2/S35
8	COM1	24	PB6/ Sin*	40	S20	56	PC3/S36
9	VLCD1/ 3	25	PB5/ SCL *	41	S21	57	PC4/S37
10	VLCD2/ 3	26	PB4 *	42	S22	58	PC5/S38
11	VLCD	27	PB3/ Ain	43	S23	59	PC6/S39
12	PA7/ Ain	28	PB2/ Ain	44	S24	60	PC7/S40
13	PA6/ Ain	29	S9	45	S25	61	S41
14	PA5/ Ain	30	S10	46	S26	62	S42
15	PA4/ Ain	31	S11	47	S27	63	S43
16	TEST	32	S12	48	S28	64	S44

\*Note: 20mA Sink

## 1.2 PIN DESCRIPTIONS

**V<sub>DD</sub> and V<sub>SS</sub>.** Power is supplied to the MCU via these two pins. V<sub>DD</sub> is the power connection and V<sub>SS</sub> is the ground connection.

**OSCin and OSCout.** These pins are internally connected to the on-chip oscillator circuit. A quartz crystal, a ceramic resonator or an external clock signal can be connected between these two pins. The OSCin pin is the input pin, the OSCout pin is the output pin.

**RESET.** The active-low  $\overline{\text{RESET}}$  pin is used to restart the microcontroller.

**TEST/V<sub>PP</sub>.** The TEST must be held at V<sub>SS</sub> for normal operation (an internal pull-down resistor selects normal operating mode if TEST pin is not connected). If TEST pin is connected to a +12.5V level during the reset phase, the EPROM/OTP programming Mode is entered.

**NMI.** The NMI pin provides the capability for asynchronous interruption, by applying an external non maskable interrupt to the MCU. The NMI input is falling edge sensitive with Schmitt trigger characteristics. The user can select as option the availability of an on-chip pull-up at this pin.

**PA4-PA7.** These 4 lines are organised as one I/O port (A). Each line may be configured under software control as input with or without internal pull-up resistors, input with interrupt generation and pull-up resistor, open-drain or push-pull outputs, or as analog inputs for the A/D converter.

**PB2...PB7.** These 6 lines are organised as one I/O port (B). Each line may be configured under soft-

ware control as input with or without internal pull-up resistors, input with interrupt generation and pull-up resistor, open-drain or push-pull output or as analog input for the A/D converter. PB0..PB3 can be used as analog inputs for the A/D converter, while PB7/Sout, PB6/Sin and PB5/Scl can be used respectively as data out, data in and Clock pins for the on-chip SPI. In addition, PB4..PB7 can sink 20mA for direct LED or TRIAC drive.

**PC0-PC7.** These 8 lines are organised as one I/O port (C). Each line may be configured under software control as input with or without internal pull-up resistor, input with interrupt generation and pull-up resistor, open-drain or push-pull output, or as LCD segment output S33..S40.

**COM1-COM4.** These four pins are the LCD peripheral common outputs. They are the outputs of the on-chip backplane voltage generator which is used for multiplexing the 45 LCD lines allowing up to 180 segments to be driven.

**S9-S48.** These pins are the 40 LCD peripheral segment outputs. S33..S40 are alternate functions of the Port C I/O pins. (Combiports feature)

**VLCD.** Display voltage supply. It determines the high voltage level on COM1-COM4 and S4-S48 pins.

**VLCD1/3, VLCD2/3.** Display supply voltage inputs for determining the display voltage levels on COM1-COM4 and S4-S48 pins during multiplex operation.

### 1.3 MEMORY MAP

#### 1.3.1 Introduction

The MCU operates in three separate memory spaces: Program space, Data space, and Stack space. Operation in these three memory spaces is described in the following paragraphs.

Briefly, Program space contains user program code in Program memory and user vectors; Data space contains user data in RAM and in Program memory, and Stack space accommodates six levels of stack for subroutine and interrupt service routine nesting.

#### 1.3.2 Program Space

Program Space comprises the instructions to be executed, the data required for immediate addressing mode instructions, the reserved factory test area and the user vectors. Program Space is addressed via the 12-bit Program Counter register (PC register).

Program Space is organised in four 2K pages. Three of them are addressed in the 000h-7FFh locations of the Program Space by the Program Counter and by writing the appropriate code in the Program ROM Page Register (PRPR register). A

common (STATIC) 2K page is available all the time for interrupt vectors and common subroutines, independently of the PRPR register content. This "STATIC" page is directly addressed in the 0800h-0FFFh by the MSB of the Program Counter register PC 11. Note this page can also be addressed in the 000-7FFh range. It is two different ways of addressing the same physical memory.

Jump from a dynamic page to another dynamic page is achieved by jumping back to the static page, changing contents of PRPR and then jumping to the new dynamic page.

Figure 3. 8Kbytes Program Space Addressing

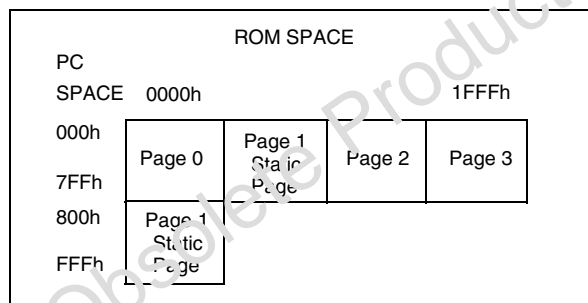
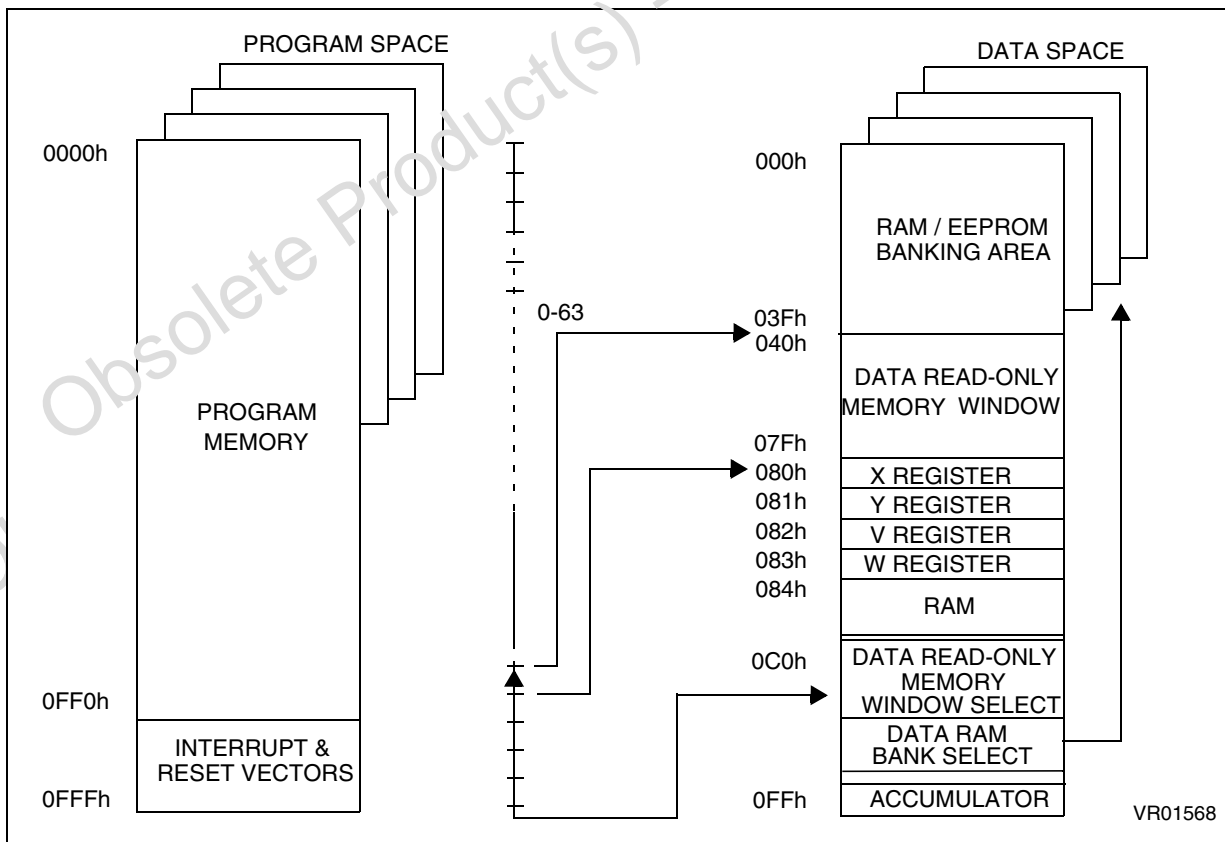

Figure 4. Memory Addressing Diagram



MEMORY MAP (Cont'd)

Table 2. ST62E42B/T42B Program Memory Map

ROM Page	Device Address	Description
Page 0	0000h-007Fh 0080h-07FFh	Reserved User ROM
Page 1 "STATIC"	0800h-0F9Fh 0FA0h-0FEFh 0FF0h-0FF7h 0FF8h-0FFBh 0FFCh-0FFDh 0FFEh-0FFFh	User ROM Reserved Interrupt Vectors Reserved NMI Vector Reset Vector
Page 2	0000h-000Fh 0010h-07FFh	Reserved User ROM
Page 3	0000h-000Fh 0010h-07FFh	Reserved User ROM

**Note:** OTP/EPROM devices can be programmed with the development tools available from STMicroelectronics (ST62E4X-EPB or ST6240-KIT).

1.3.2.1 Program ROM Page Register (PRPR)

The PRPR register can be addressed like a RAM location in the Data Space at the address CAh ; nevertheless it is a write only register that cannot be accessed with single-bit operations. This register is used to select the 2-Kbyte ROM bank of the Program Space that will be addressed. The number of the page has to be loaded in the PRPR register. Refer to the Program Space description for additional information concerning the use of this register. The PRPR register is not modified when an interrupt or a subroutine occurs.

Care is required when handling the PRPR register as it is write only. For this reason, it is not allowed to change the PRPR contents while executing interrupt service routine, as the service routine cannot save and then restore its previous content. This operation may be necessary if common routines and interrupt service routines take more than 2K bytes; in this case it could be necessary to divide the interrupt service routine into a (minor) part in the static page (start and end) and to a second (major) part in one of the dynamic pages. If it is impossible to avoid the writing of this register in interrupt service routines, an image of this register must be saved in a RAM location, and each time the program writes to the PRPR it must write also to the image register. The image register must be written before PRPR, so if an interrupt occurs between the two instructions the PRPR is not affected.

Program ROM Page Register (PRPR)

Address: CAh — Write Only

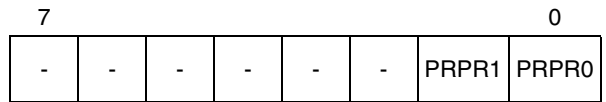

Bits 7-2= Not used.

Bit 1-0 = **PRPR1-PRPR0**: *Program ROM Select*. These two bits select the corresponding page to be addressed in the lower part of the 4K program address space as specified in Table 3.

**Caution:** *this register is undefined on Reset. Neither read nor single bit instructions may be used to address this register.*

Table 3. 8Kbytes Program ROM Page Register Coding

PRPR1	PRPR0	PC bit 11	Memory Page
X	X	1	Static Page (Page 1)
0	0	0	Page 0
0	1	0	Page 1 (Static Page)
1	0	0	Page 2
1	1	0	Page 3

1.3.2.2 Program Memory Protection

The Program Memory in OTP or EPROM devices can be protected against external readout of memory by selecting the READOUT PROTECTION option in the option byte.

In the EPROM parts, READOUT PROTECTION option can be deactivated only by U.V. erasure that also results into the whole EPROM context erasure.

**Note:** Once the Readout Protection is activated, it is no longer possible, even for STMicroelectronics, to gain access to the Program memory contents. Returned parts with a protection set can therefore not be accepted.

**MEMORY MAP (Cont'd)****1.3.3 Data Space**

Data Space accommodates all the data necessary for processing the user program. This space comprises the RAM resource, the processor core and peripheral registers, as well as read-only data such as constants and look-up tables in Program memory.

**1.3.3.1 Data ROM**

All read-only data is physically stored in program memory, which also accommodates the Program Space. The program memory consequently contains the program code to be executed, as well as the constants and look-up tables required by the application.

The Data Space locations in which the different constants and look-up tables are addressed by the processor core may be thought of as a 64-byte window through which it is possible to access the read-only data stored in Program memory.

**1.3.3.2 Data RAM/EEPROM**

In ST62T42B and ST62E42B devices, the data space includes 60 bytes of RAM, the accumulator (A), the indirect registers (X), (Y), the short direct registers (V), (W), the I/O port registers, the peripheral data and control registers, the interrupt option register and the Data ROM Window Register (DRW register).

Additional RAM and EEPROM pages can also be addressed using banks of 64 bytes located between addresses 00h and 3Fh.

**1.3.4 Stack Space**

Stack space consists of six 12-bit registers which are used to stack subroutine and interrupt return addresses, as well as the current program counter contents.

**Table 4. Additional RAM/EEPROM Banks.**

Device	RAM	EEPROM
ST62T42B/E42B	2 x 64 bytes	2 x 64 bytes

**Table 5. ST62T42B/E42B Data Memory Space**

DATA and EEPROM	000h
	03Fh
DATA ROM WINDOW AREA	040h
	07Fh
X REGISTER	080h
Y REGISTER	081h
V REGISTER	082h
W REGISTER	083h
DATA RAM	084h
	0BFh
PORT A DATA REGISTER	0C0h
PORT B DATA REGISTER	0C1h
SPI INTERRUPT DISABLE REGISTER	0C2h
PORT C DATA REGISTER	0C3h
PORT A DIRECTION REGISTER	0C4h
PORT B DIRECTION REGISTER	0C5h
PORT C DIRECTION REGISTER	0C6h
RESERVED	0C7h
INTERRUPT OPTION REGISTER	0C8h*
DATA ROM WINDOW REGISTER	0C9h*
ROM BANK SELECT REGISTER	0CAh*
RAM/EEPROM BANK SELECT REGISTER	0CBh*
PORT A OPTION REGISTER	0CCh
RESERVED	0CDh
PORT B OPTION REGISTER	0CEh
PORT C OPTION REGISTER	0CFh
A/D DATA REGISTER	0D0h
A/D CONTROL REGISTER	0D1h
TIMER 1 PRESCALER REGISTER	0D2h
TIMER 1 COUNTER REGISTER	0D3h
TIMER 1 STATUS/CONTROL REGISTER	0D4h
TIMER 2 PRESCALER REGISTER	0D5h
TIMER 2 COUNTER REGISTER	0D6h
TIMER 2 STATUS/CONTROL REGISTER	0D7h
WATCHDOG REGISTER	0D8h
RESERVED	0D9h
RESERVED	0DAh
RESERVED	0DBh
LCD MODE CONTROL REGISTER	0DCh
SPI DATA REGISTER	0DDh
RESERVED	0DEh
EEPROM CONTROL REGISTER	0DFh
	0E0h
LCD RAM	0F7h
	0F8h
DATA RAM	0FEh
	0FFh
ACCUMULATOR	0FFh

\* WRITE ONLY REGISTER

MEMORY MAP (Cont'd)

1.3.5 Data Window Register (DWR)

The Data Read-Only Memory window is located from address 0040h to address 007Fh in Data space. It allows direct reading of 64 consecutive bytes located anywhere in program memory, between address 0000h and 1FFFh (top memory address depends on the specific device). All the program memory can therefore be used to store either instructions or read-only data. Indeed, the window can be moved in steps of 64 bytes along the program memory by writing the appropriate code in the Data Window Register (DWR).

The DWR can be addressed like any RAM location in the Data Space, it is however a write-only register and therefore cannot be accessed using single-bit operations. This register is used to position the 64-byte read-only data window (from address 40h to address 7Fh of the Data space) in program memory in 64-byte steps. The effective address of the byte to be read as data in program memory is obtained by concatenating the 6 least significant bits of the register address given in the instruction (as least significant bits) and the content of the DWR register (as most significant bits), as illustrated in Figure 5 below. For instance, when addressing location 0040h of the Data Space, with 0 loaded in the DWR register, the physical location addressed in program memory is 00h. The DWR register is not cleared on reset, therefore it must be written to prior to the first access to the Data read-only memory window area.

Data Window Register (DWR)

Address: 0C9h — Write Only

7							0
-	-	DWR5	DWR4	DWR3	DWR2	DWR1	DWR0

Bits 6, 7 = Not used.

Bit 5-0 = **DWR5-DWR0**: Data read-only memory Window Register Bits. These are the Data read-only memory Window bits that correspond to the upper bits of the data read-only memory space

**Caution:** This register is undefined on reset. Neither read nor single bit instructions may be used to address this register.

**Note:** Care is required when handling the DWR register as it is write only. For this reason, the DWR contents should not be changed while executing an interrupt service routine, as the service routine cannot save and then restore the register's previous contents. If it is impossible to avoid writing to the DWR during the interrupt service routine, an image of the register must be saved in a RAM location, and each time the program writes to the DWR, it must also write to the image register. The image register must be written first so that, if an interrupt occurs between the two instructions, the DWR is not affected.

Figure 5. Data read-only memory Window Memory Addressing

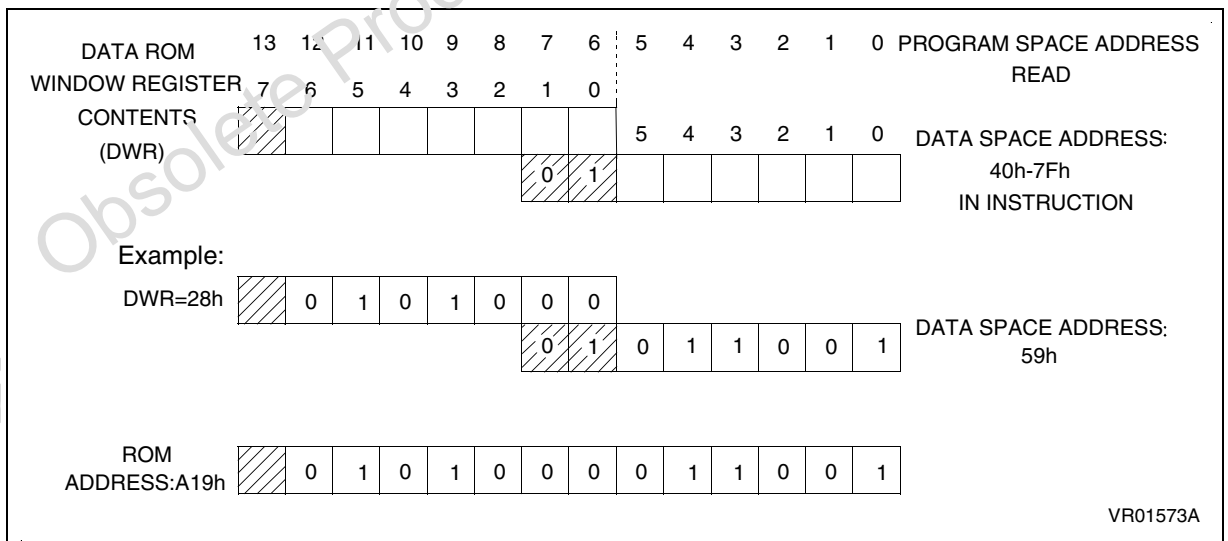

VR01573A

**MEMORY MAP** (Cont'd)**1.3.6 Data RAM/EEPROM Bank Register (DRBR)**

Address: CBh — Write only

7							0
-	-	-	DRBR4	DRBR3	-	DRBR1	DRBR0

Bit 7-5 = These bits are not used

Bit 4 - **DRBR4**. This bit, when set, selects RAM Page 2.Bit 3 - **DRBR3**. This bit, when set, selects RAM Page 1.

Bit 2. This bit is not used.

Bit 1 - **DRBR1**. This bit, when set, selects EEPROM Page 1.Bit 0 - **DRBR0**. This bit, when set, selects EEPROM Page 0.

The selection of the bank is made by programming the Data RAM Bank Switch register (DRBR register) located at address CBh of the Data Space according to Table 1. No more than one bank should be set at a time.

The DRBR register can be addressed like a RAM Data Space at the address CBh; nevertheless it is a write only register that cannot be accessed with single-bit operations. This register is used to select the desired 64-byte RAM/EEPROM bank of the Data Space. The number of banks has to be loaded in the DRBR register and the instruction has to point to the selected location as if it was in bank 0 (from 00h address to 3Fh address).

This register is not cleared during the MCU initialization, therefore it must be written before the first access to the Data Space bank region. Refer to the Data Space description for additional information. The DRBR register is not modified when an interrupt or a subroutine occurs.

**Notes :**

Care is required when handling the DRBR register as it is write only. For this reason, it is not allowed to change the DRBR contents while executing interrupt service routine, as the service routine cannot save and then restore its previous content. If it is impossible to avoid the writing of this register in interrupt service routine, an image of this register must be saved in a RAM location, and each time the program writes to DRBR it must write also to the image register. The image register must be written first, so if an interrupt occurs between the two instructions the DRBR is not affected.

In DRBR Register, only 1 bit must be set. Otherwise two or more pages are enabled in parallel, producing errors.

**Table 6. Data RAM Bank Register Set-up**

DRBR	ST62T42B/E42B
00h	None
01h	EEPROM Page 0
02h	EEPROM Page 1
08h	RAM Page 1
10h1	RAM Page 2
other	Reserved

**MEMORY MAP (Cont'd)**

**1.3.7 EEPROM Description**

EEPROM memory is located in 64-byte pages in data space. This memory may be used by the user program for non-volatile data storage.

Data space from 00h to 3Fh is paged as described in Table 7. EEPROM locations are accessed directly by addressing these paged sections of data space.

The EEPROM does not require dedicated instructions for read or write access. Once selected via the Data RAM Bank Register, the active EEPROM page is controlled by the EEPROM Control Register (EECTL), which is described below.

Bit E2OFF of the EECTL register must be reset prior to any write or read access to the EEPROM. If no bank has been selected, or if E2OFF is set, any access is meaningless.

Programming must be enabled by setting the E2ENA bit of the EECTL register.

The E2BUSY bit of the EECTL register is set when the EEPROM is performing a programming cycle. Any access to the EEPROM when E2BUSY is set is meaningless.

Provided E2OFF and E2BUSY are reset, an EEPROM location is read just like any other data location, also in terms of access time.

Writing to the EEPROM may be carried out in two modes: Byte Mode (BMODE) and Parallel Mode

(PMODE). In BMODE, one byte is accessed at a time, while in PMODE up to 8 bytes in the same row are programmed simultaneously (with consequent speed and power consumption advantages, the latter being particularly important in battery powered circuits).

**General Notes:**

Data should be written directly to the intended address in EEPROM space. There is no buffer memory between data RAM and the EEPROM space.

When the EEPROM is busy (E2BUSY = "1"), EECTL cannot be accessed in write mode, it is only possible to read the status of E2BUSY. This implies that as long as the EEPROM is busy, it is not possible to change the status of the EEPROM Control Register. EECTL bits 4 and 5 are reserved and must never be set.

Care is required when dealing with the EECTL register, as some bits are write only. For this reason, the EECTL contents must not be altered while executing an interrupt service routine.

If it is impossible to avoid writing to this register within an interrupt service routine, an image of the register must be saved in a RAM location, and each time the program writes to EECTL it must also write to the image register. The image register must be written to first so that, if an interrupt occurs between the two instructions, the EECTL will not be affected.

**Table 7. Row Arrangement for Parallel Writing of EEPROM Locations**

Byte	0	1	2	3	4	5	6	7	Dataspace addresses. Banks 0 and 1.
ROW7									38h-3Fh
ROW6									30h-37h
ROW5									28h-2Fh
ROW4									20h-27h
ROW3									18h-1Fh
ROW2									10h-17h
ROW1									08h-0Fh
ROW0									00h-07h

Up to 8 bytes in each row may be programmed simultaneously in Parallel Write mode.  
The number of available 64-byte banks (1 or 2) is device dependent.

## MEMORY MAP (Cont'd)

### Additional Notes on Parallel Mode:

If the user wishes to perform parallel programming, the first step should be to set the E2PAR2 bit. From this time on, the EEPROM will be addressed in write mode, the ROW address will be latched and it will be possible to change it only at the end of the programming cycle, or by resetting E2PAR2 without programming the EEPROM. After the ROW address is latched, the MCU can only "see" the selected EEPROM row and any attempt to write or read other rows will produce errors.

The EEPROM should not be read while E2PAR2 is set.

As soon as the E2PAR2 bit is set, the 8 volatile ROW latches are cleared. From this moment on, the user can load data in all or in part of the ROW. Setting E2PAR1 will modify the EEPROM registers corresponding to the ROW latches accessed after E2PAR2. For example, if the software sets E2PAR2 and accesses the EEPROM by writing to addresses 18h, 1Ah and 1Bh, and then sets E2PAR1, these three registers will be modified simultaneously; the remaining bytes in the row will be unaffected.

Note that E2PAR2 is internally reset at the end of the programming cycle. This implies that the user must set the E2PAR2 bit between two parallel programming cycles. Note that if the user tries to set E2PAR1 while E2PAR2 is not set, there will be no programming cycle and the E2PAR1 bit will be unaffected. Consequently, the E2PAR1 bit cannot be set if E2ENA is low. The E2PAR1 bit can be set by the user, only if the E2ENA and E2PAR2 bits are also set.

### EEPROM Control Register (EECTL)

Address: DFh -- Read/Write

Reset status: 00h

7							0
D7	E2OFF	D5	D4	E2PAR1	E2PAR2	E2BUSY	E2ENA

Bit 7 = **D7**: *Unused.*

Bit 6 = **E2OFF**: *Stand-by Enable Bit. WRITE ONLY.* If this bit is set the EEPROM is disabled (any access will be meaningless) and the power consumption of the EEPROM is reduced to its lowest value.

Bit 5-4 = **D5-D4**: *Reserved. MUST be kept reset.*

Bit 3 = **E2PAR1**: *Parallel Start Bit. WRITE ONLY.* Once in Parallel Mode, as soon as the user software sets the E2PAR1 bit, parallel writing of the 8 adjacent registers will start. This bit is internally reset at the end of the programming procedure. Note that less than 8 bytes can be written if required, the undefined bytes being unaffected by the parallel programming cycle; this is explained in greater detail in the Additional Notes on Parallel Mode overleaf.

Bit 2 = **E2PAR2**: *Parallel Mode En. Bit. WRITE ONLY.* This bit must be set by the user program in order to perform parallel programming. If E2PAR2 is set and the parallel start bit (E2PAR1) is reset, up to 8 adjacent bytes can be written simultaneously. These 8 adjacent bytes are considered as a row, whose address lines A7, A6, A5, A4, A3 are fixed while A2, A1 and A0 are the changing bits, as illustrated in Table 7. E2PAR2 is automatically reset at the end of any parallel programming procedure. It can be reset by the user software before starting the programming procedure, thus leaving the EEPROM registers unchanged.

Bit 1 = **E2BUSY**: *EEPROM Busy Bit. READ ONLY.* This bit is automatically set by the EEPROM control logic when the EEPROM is in programming mode. The user program should test it before any EEPROM read or write operation; any attempt to access the EEPROM while the busy bit is set will be aborted and the writing procedure in progress will be completed.

Bit 0 = **E2ENA**: *EEPROM Enable Bit. WRITE ONLY.* This bit enables programming of the EEPROM cells. It must be set before any write to the EEPROM register. Any attempt to write to the EEPROM when E2ENA is low is meaningless and will not trigger a write cycle.

**Caution:** *This register is undefined on reset. Neither read nor single bit instructions may be used to address this register.*

## 1.4 PROGRAMMING MODES

### 1.4.1 Option Byte

The Option Byte allows configuration capability to the MCUs. Option byte's content is automatically read, and the selected options enabled, when the chip reset is activated.

It can only be accessed during the programming mode. This access is made either automatically (copy from a master device) or by selecting the OPTION BYTE PROGRAMMING mode of the programmer.

The option byte is located in a non-user map. No address has to be specified.

#### EPROM Code Option Byte

7							0
-	NMI PULL	PRO- TECT	-	WDACT	-	-	-

Bit 7. Reserved.

Bit 6 = **NMI PULL**. This bit must be set high to remove the NMI pin pull up resistor when it is low, a pull up is provided.

Bit 5 = **PROTECT**. This bit allows the protection of the software contents against piracy. When the bit PROTECT is set high, readout of the OTP contents is prevented by hardware. No programming equipment is able to gain access to the user program. When this bit is low, the user program can be read.

Bit 4. Reserved.

Bit 3 = **WDACT**. This bit controls the watchdog activation. When it is high, hardware activation is selected. The software activation is selected when WDACT is low.

Bit 2 = Reserved. Must be set to 1.

Bit 1-0 = Reserved.

The Option byte is written during programming either by using the PC menu (PC driven Mode) or automatically (stand-alone mode)

### 1.4.2 Program Memory

EPROM/OTP programming mode is set by a +12.5V voltage applied to the TEST/V<sub>PP</sub> pin. The programming flow of the ST62T42B/E42B is described in the User Manual of the EPROM Programming Board.

The MCUs can be programmed with the ST62E4xB EPROM programming tools available from STMicroelectronics.

### 1.4.3 EEPROM Data Memory

EEPROM data pages are supplied in the virgin state FFh. Partial or total programming of EEPROM data memory can be performed either through the application software, or through an external programmer. Any STMicroelectronics tool used for the program memory (OTP EPROM) can also be used to program the EEPROM data memory.

### 1.4.4 EPROM Erasing

The EPROM of the windowed package of the MCUs may be erased by exposure to Ultra Violet light. The erasure characteristic of the MCUs is such that erasure begins when the memory is exposed to light with a wave lengths shorter than approximately 4000Å. It should be noted that sunlights and some types of fluorescent lamps have wavelengths in the range 3000-4000Å.

It is thus recommended that the window of the MCUs packages be covered by an opaque label to prevent unintentional erasure problems when testing the application in such an environment.

The recommended erasure procedure of the MCUs EPROM is the exposure to short wave ultraviolet light which have a wave-length 2537Å. The integrated dose (i.e. U.V. intensity x exposure time) for erasure should be a minimum of 15W-sec/cm<sup>2</sup>. The erasure time with this dosage is approximately 15 to 20 minutes using an ultraviolet lamp with 12000μW/cm<sup>2</sup> power rating. The ST62E42B should be placed within 2.5cm (1Inch) of the lamp tubes during erasure.

## 2 CENTRAL PROCESSING UNIT

### 2.1 INTRODUCTION

The CPU Core of ST6 devices is independent of the I/O or Memory configuration. As such, it may be thought of as an independent central processor communicating with on-chip I/O, Memory and Peripherals via internal address, data, and control buses. In-core communication is arranged as shown in Figure 6; the controller being externally linked to both the Reset and Oscillator circuits, while the core is linked to the dedicated on-chip peripherals via the serial data bus and indirectly, for interrupt purposes, through the control registers.

### 2.2 CPU REGISTERS

The ST6 Family CPU core features six registers and three pairs of flags available to the programmer. These are described in the following paragraphs.

**Accumulator (A).** The accumulator is an 8-bit general purpose register used in all arithmetic calculations, logical operations, and data manipulations. The accumulator can be addressed in Data space as a RAM location at address FFh. Thus the ST6 can manipulate the accumulator just like any other register in Data space.

**Indirect Registers (X, Y).** These two indirect registers are used as pointers to memory locations in Data space. They are used in the register-indirect addressing mode. These registers can be addressed in the data space as RAM locations at addresses 80h (X) and 81h (Y). They can also be accessed with the direct, short direct, or bit direct addressing modes. Accordingly, the ST6 instruction set can use the indirect registers as any other register of the data space.

**Short Direct Registers (V, W).** These two registers are used to save a byte in short direct addressing mode. They can be addressed in Data space as RAM locations at addresses 82h (V) and 83h (W). They can also be accessed using the direct and bit direct addressing modes. Thus, the ST6 instruction set can use the short direct registers as any other register of the data space.

**Program Counter (PC).** The program counter is a 12-bit register which contains the address of the next ROM location to be processed by the core. This ROM location may be an opcode, an operand, or the address of an operand. The 12-bit length allows the direct addressing of 4096 bytes in Program space.

Figure 6. ST6 Core Block Diagram

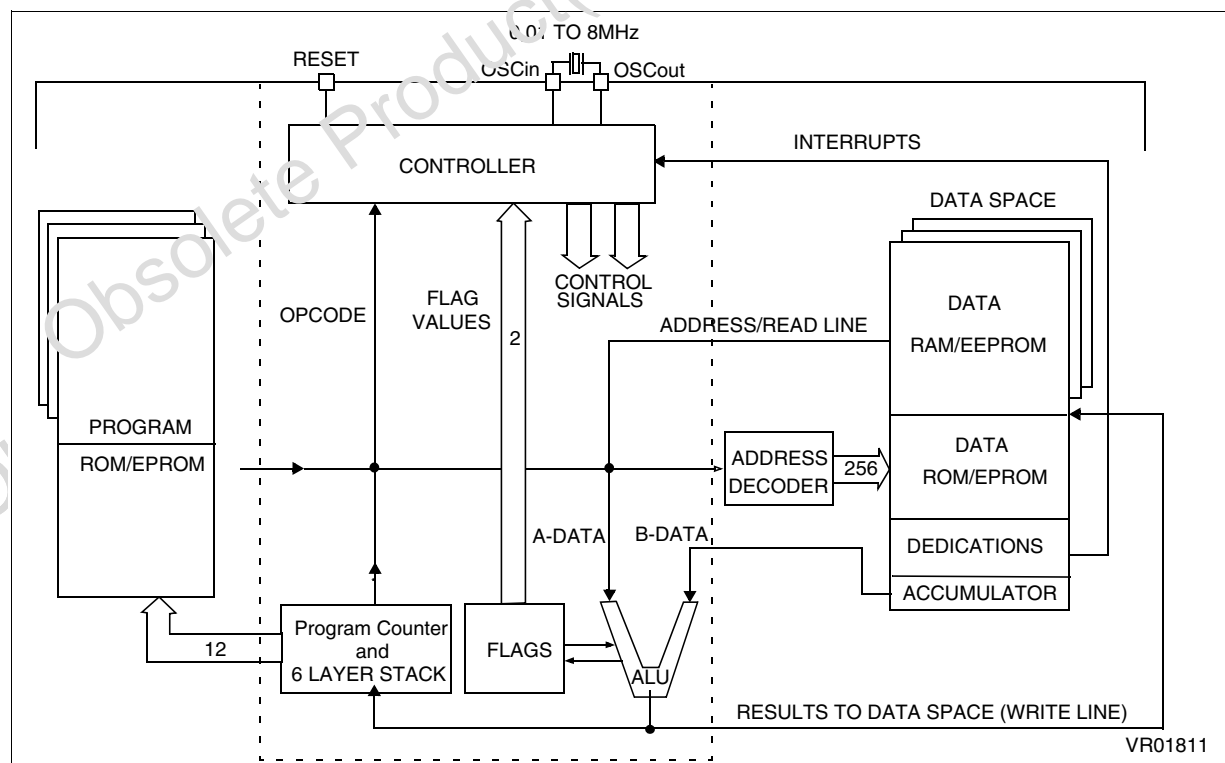

**CPU REGISTERS** (Cont'd)

However, if the program space contains more than 4096 bytes, the additional memory in program space can be addressed by using the Program Bank Switch register.

The PC value is incremented after reading the address of the current instruction. To execute relative jumps, the PC and the offset are shifted through the ALU, where they are added; the result is then shifted back into the PC. The program counter can be changed in the following ways:

- JP (Jump) instruction PC=Jump address
- CALL instruction PC= Call address
- Relative Branch Instruction. PC= PC +/- offset
- Interrupt PC=Interrupt vector
- Reset PC= Reset vector
- RET & RETI instructions PC= Pop (stack)
- Normal instruction PC= PC + 1

**Flags (C, Z).** The ST6 CPU includes three pairs of flags (Carry and Zero), each pair being associated with one of the three normal modes of operation: Normal mode, Interrupt mode and Non Maskable Interrupt mode. Each pair consists of a CARRY flag and a ZERO flag. One pair (CN, ZN) is used during Normal operation, another pair is used during Interrupt mode (CI, ZI), and a third pair is used in the Non Maskable Interrupt mode (CNMI, ZNMI).

The ST6 CPU uses the pair of flags associated with the current mode: as soon as an interrupt (or a Non Maskable Interrupt) is generated, the ST6 CPU uses the Interrupt flags (resp. the NMI flags) instead of the Normal flags. When the RETI instruction is executed, the previously used set of flags is restored. It should be noted that each flag set can only be addressed in its own context (Non Maskable Interrupt, Normal Interrupt or Main routine). The flags are not cleared during context switching and thus retain their status.

The Carry flag is set when a carry or a borrow occurs during arithmetic operations; otherwise it is cleared. The Carry flag is also set to the value of the bit tested in a bit test instruction; it also participates in the rotate left instruction.

The Zero flag is set if the result of the last arithmetic or logical operation was equal to zero; otherwise it is cleared.

Switching between the three sets of flags is performed automatically when an NMI, an interrupt or a RETI instructions occurs. As the NMI mode is

automatically selected after the reset of the MCU, the ST6 core uses at first the NMI flags.

**Stack.** The ST6 CPU includes a true LIFO hardware stack which eliminates the need for a stack pointer. The stack consists of six separate 12-bit RAM locations that do not belong to the data space RAM area. When a subroutine call (or interrupt request) occurs, the contents of each level are shifted into the next higher level, while the content of the PC is shifted into the first level (the original contents of the sixth stack level are lost). When a subroutine or interrupt return occurs (RET or RETI instructions), the first level register is shifted back into the PC and the value of each level is popped back into the previous level. Since the accumulator, in common with all other data space registers, is not stored in this stack, management of these registers should be performed within the subroutine. The stack will remain in its "deepest" position if more than 6 nested calls or interrupts are executed, and consequently the last return address will be lost. It will also remain in its highest position if the stack is empty and a RET or RETI is executed. In this case the next instruction will be executed.

**Figure 7. ST6 CPU Programming Mode**

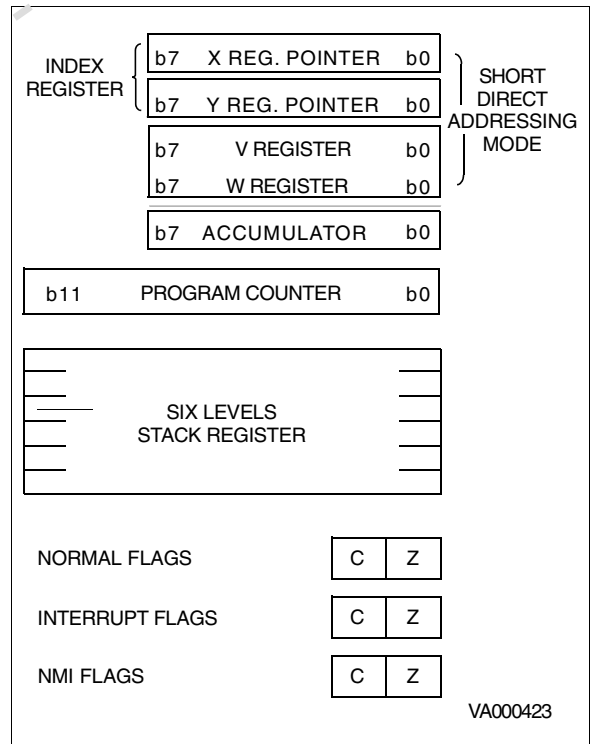

### 3 CLOCKS, RESET, INTERRUPTS AND POWER SAVING MODES

#### 3.1 CLOCK SYSTEM

##### 3.1.1 Main Oscillator

The MCU features a Main Oscillator which can be driven by an external clock, or used in conjunction with an AT-cut parallel resonant crystal or a suitable ceramic resonator.

Figure 8 illustrates various possible oscillator configurations using an external crystal or ceramic resonator, an external clock input.  $C_{L1}$  and  $C_{L2}$  should have a capacitance in the range 12 to 22 pF for an oscillator frequency in the 4-8 MHz range.

The internal MCU clock Frequency ( $F_{INT}$ ) is divided by 13 to drive the CPU core and by 12 to drive the A/D converter and the watchdog timer, while clock used to drive on-chip peripherals depends on the peripheral as shown in the clock circuit block diagram.

With an 8MHz oscillator frequency, the fastest machine cycle is therefore 1.625 $\mu$ s.

A machine cycle is the smallest unit of time needed to execute any operation (for instance, to increment the Program Counter). An instruction may require two, four, or five machine cycles for execution.

Figure 8. Oscillator Configurations

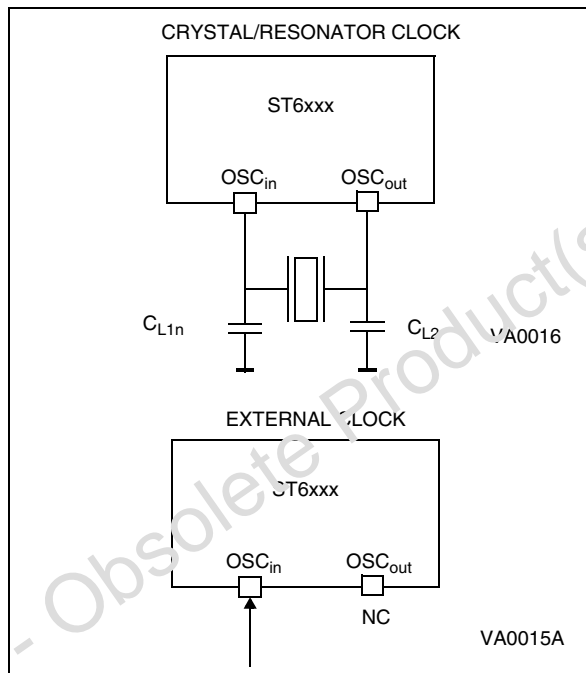
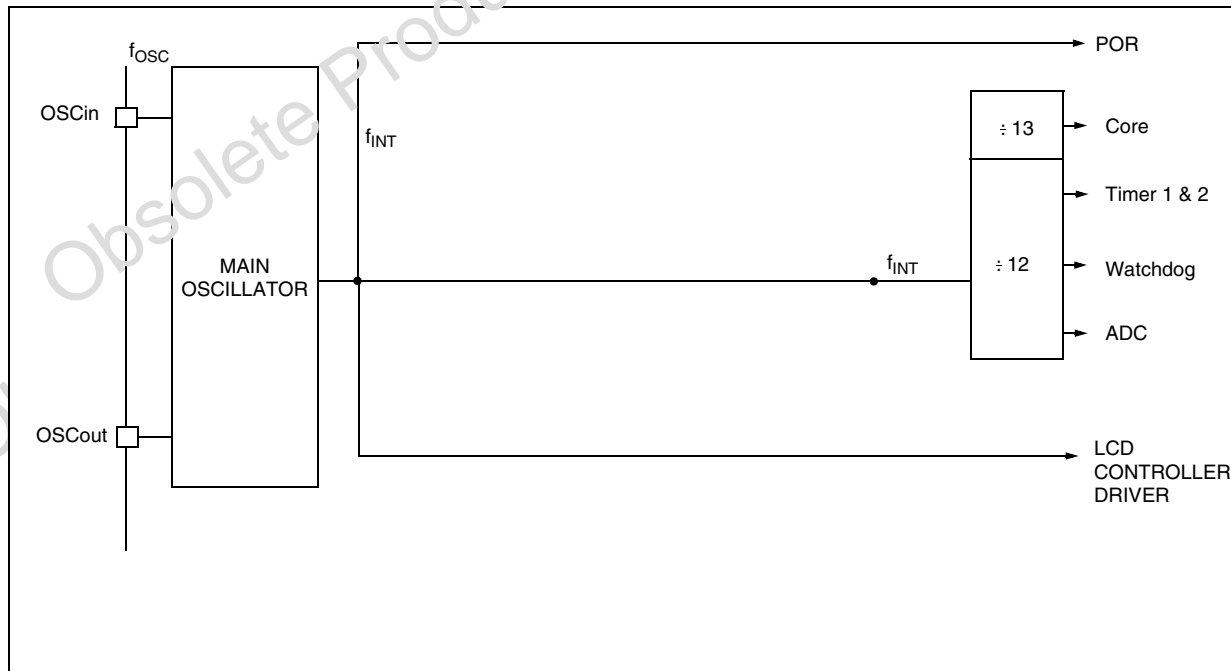

Figure 9. Clock Circuit Block Diagram



## 3.2 RESETS

The MCU can be reset in three ways:

- by the external Reset input being pulled low;
- by Power-on Reset;
- by the digital Watchdog peripheral timing out.

### 3.2.1 RESET Input

The  $\overline{\text{RESET}}$  pin may be connected to a device of the application board in order to reset the MCU if required. The  $\overline{\text{RESET}}$  pin may be pulled low in RUN, WAIT or STOP mode. This input can be used to reset the MCU internal state and ensure a correct start-up procedure. The pin is active low and features a Schmitt trigger input. The internal Reset signal is generated by adding a delay to the external signal. Therefore even short pulses on the  $\overline{\text{RESET}}$  pin are acceptable, provided  $V_{DD}$  has completed its rising phase and that the oscillator is running correctly (normal RUN or WAIT modes). The MCU is kept in the Reset state as long as the  $\overline{\text{RESET}}$  pin is held low.

If  $\overline{\text{RESET}}$  activation occurs in the RUN or WAIT modes, processing of the user program is stopped (RUN mode only), the Inputs and Outputs are configured as inputs with pull-up resistors and the main Oscillator is restarted. When the level on the  $\overline{\text{RESET}}$  pin then goes high, the initialization sequence is executed following expiry of the internal delay period.

If  $\overline{\text{RESET}}$  pin activation occurs in the STOP mode, the oscillator starts up and all Inputs and Outputs are configured as inputs with pull up resistors. When the level of the  $\overline{\text{RESET}}$  pin then goes high, the initialization sequence is executed following expiry of the internal delay period.

### 3.2.2 Power-on Reset

The function of the POR circuit consists in waking up the MCU at an appropriate stage during the power-on sequence. At the beginning of this sequence the MCU is configured in the Reset state: all I/O ports are configured as inputs with pull-up resistors and no instruction is executed. When the power supply voltage rises to a sufficient level, the oscillator starts to operate, whereupon an internal delay is initiated, in order to allow the oscillator to fully stabilize before executing the first instruction. The initialization sequence is executed immediately following the internal delay.

The internal delay is generated by an on-chip counter. The internal reset line is released 2048 internal clock cycles after release of the external reset.

#### Notes:

To ensure correct start-up, the user should take care that the reset signal is not released before the  $V_{DD}$  level is sufficient to allow MCU operation at the chosen frequency (see Recommended Operating Conditions).

A proper reset signal for a slow rising  $V_{DD}$  supply can generally be provided by an external RC network connected to the  $\overline{\text{RESET}}$  pin.

Figure 10. Reset and Interrupt Processing

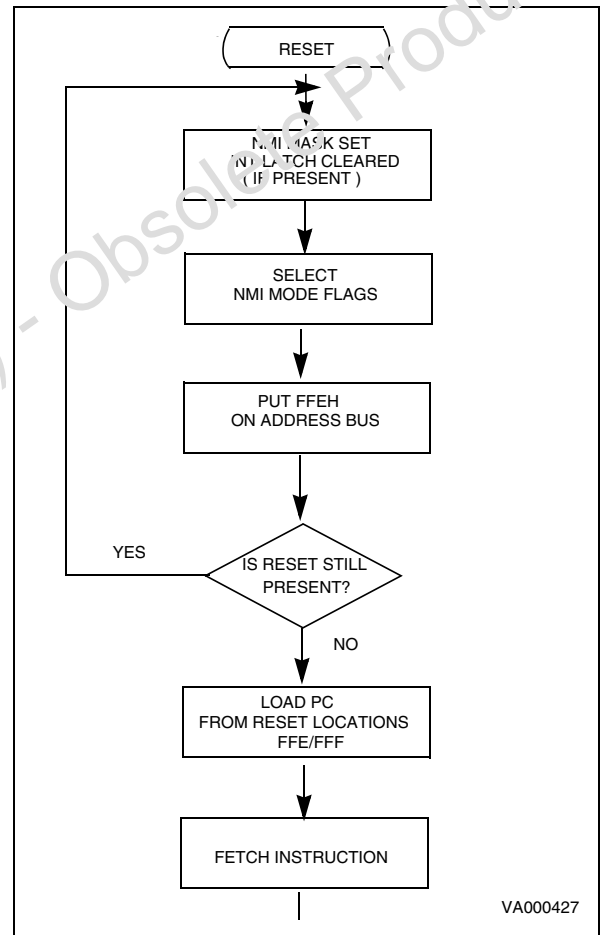

## RESETS (Cont'd)

### 3.2.3 Watchdog Reset

The MCU provides a Watchdog timer function in order to ensure graceful recovery from software upsets. If the Watchdog register is not refreshed before an end-of-count condition is reached, the internal reset will be activated. This, amongst other things, resets the watchdog counter.

The MCU restarts just as though the Reset had been generated by the RESET pin, including the built-in stabilisation delay period.

### 3.2.4 Application Notes

No external resistor is required between  $V_{DD}$  and the Reset pin, thanks to the built-in pull-up device.

The POR circuit operates dynamically, in that it triggers MCU initialization on detecting the rising edge of  $V_{DD}$ . The typical threshold is in the region of 2 volts, but the actual value of the detected threshold depends on the way in which  $V_{DD}$  rises.

The POR circuit is *NOT* designed to supervise static, or slowly rising or falling  $V_{DD}$ .

### 3.2.5 MCU Initialization Sequence

When a reset occurs the stack is reset, the PC is loaded with the address of the Reset Vector (located in program ROM starting at address 0FFEh). A jump to the beginning of the user program must be coded at this address. Following a Reset, the Interrupt flag is automatically set, so that the CPU is in Non Maskable Interrupt mode; this prevents the

initialisation routine from being interrupted. The initialisation routine should therefore be terminated by a RETI instruction, in order to revert to normal mode and enable interrupts. If no pending interrupt is present at the end of the initialisation routine, the MCU will continue by processing the instruction immediately following the RETI instruction. If, however, a pending interrupt is present, it will be serviced.

Figure 11. Reset and Interrupt Processing

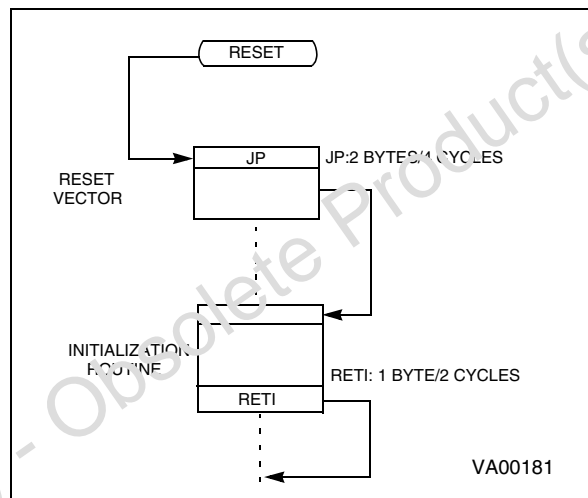
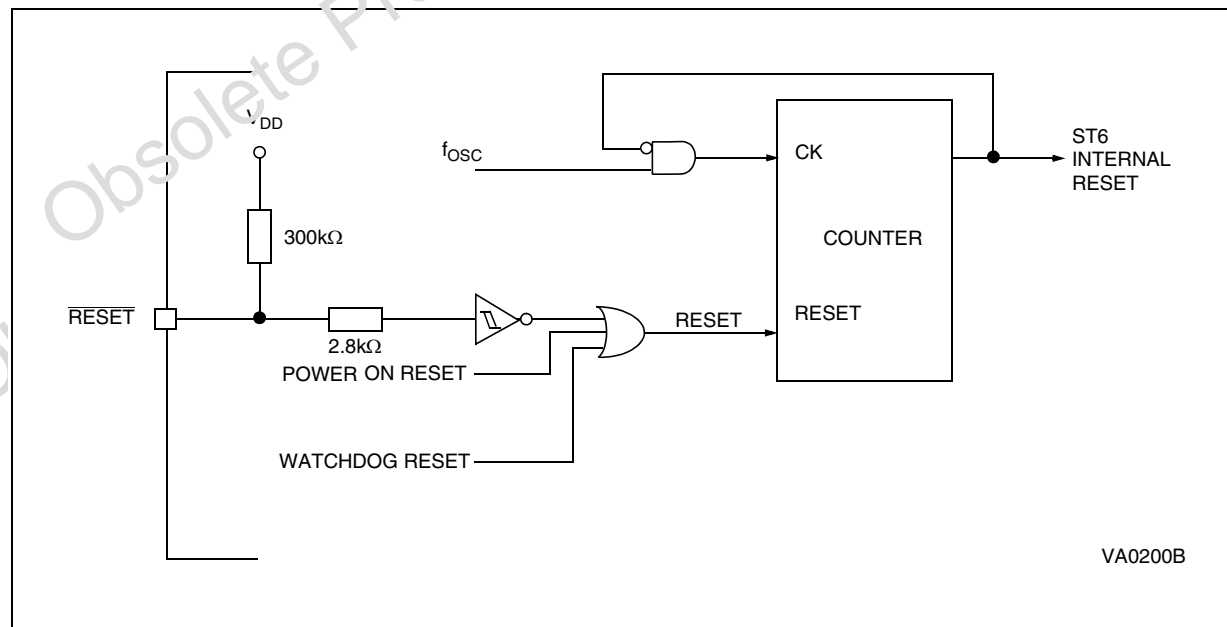

Figure 12. Reset Block Diagram



## RESETS (Cont'd)

Table 8. Register Reset Status

Register	Address(es)	Status	Comment
EEPROM Control Register	0DFh	00h	EEPROM enabled
Port Data Registers	0C0h, 0C2h, 0C3h		I/O are Input with pull-up
Port A,B Direction Register	0C4h to 0C5h		
Port A,B Option Register	0CCh, 0CEh		
Interrupt Option Register	0C8h		Interrupt disabled
SPI Registers	0C2h to 0DDh		SPI disabled
LCD Mode Control Register	0DCh	FFh	LCD display off
32kHz Oscillator Register	0DBh		Interrupt disabled
Port C Direction Register	0C6h		LCD Output
Port C Option Register	0CFh		
X, Y, V, W, Register	080H TO 083H	Undefined	As written if programmed
Accumulator	0FFh		
Data RAM	084h to 0BFh		
Data RAM Page REgister	0CBh		
Data ROM Window Register	0C9h		
EEPROM	00h to 03Fh		
A/D Result Register	0D0h		
TIMER 1 Status/Control	0D4h	00h	TIMER 1 disabled/Max count loaded
TIMER 1 Counter Register	0D3h	FFh	
TIMER 1 Prescaler Register	0D2h	7Fh	
TIMER 2 Status/Control	0D7h	00h	TIMER 2 disabled/Max count loaded
TIMER 2 Counter Register	0E5h	FFh	
TIMER 2 Prescaler Register	0D6h	7Fh	
Watchdog Counter Register	0D8h	FEh	A/D in Standby
A/D Control Register	0D1h	40h	

### 3.3 DIGITAL WATCHDOG

The digital Watchdog consists of a reloadable downcounter timer which can be used to provide controlled recovery from software upsets.

The Watchdog circuit generates a Reset when the downcounter reaches zero. User software can prevent this reset by reloading the counter, and should therefore be written so that the counter is regularly reloaded while the user program runs correctly. In the event of a software mishap (usually caused by externally generated interference), the user program will no longer behave in its usual fashion and the timer register will thus not be reloaded periodically. Consequently the timer will decrement down to 00h and reset the MCU. In order to maximise the effectiveness of the Watchdog function, user software must be written with this concept in mind.

Watchdog behaviour is governed by one option, known as "WATCHDOG ACTIVATION" (i.e. HARDWARE or SOFTWARE) (See Table 9).

In the SOFTWARE option, the Watchdog is disabled until bit C of the DWDR register has been set. When the Watchdog is disabled, low power Stop mode is available. Once activated, the Watchdog cannot be disabled, except by resetting the MCU.

In the HARDWARE option, the Watchdog is permanently enabled. Since the oscillator will run continuously, low power mode is not available. The STOP instruction is interpreted as a WAIT instruction, and the Watchdog continues to countdown.

When the MCU exits STOP mode (i.e. when an interrupt is generated), the Watchdog resumes its activity.

**Table 9. Recommended Option Choices**

Functions Required	Recommended Options
Stop Mode	"SOFTWARE WATCHDOG"
Watchdog	"HARDWARE WATCHDOG"

**DIGITAL WATCHDOG (Cont'd)**

The Watchdog is associated with a Data space register (Digital WatchDog Register, DWDR, location 0D8h) which is described in greater detail in [Section 3.3.1 Digital Watchdog Register \(DWDR\)](#). This register is set to 0FEh on Reset: bit C is cleared to "0", which disables the Watchdog; the timer downcounter bits, T0 to T5, and the SR bit are all set to "1", thus selecting the longest Watchdog timer period. This time period can be set to the user's requirements by setting the appropriate value for bits T0 to T5 in the DWDR register. The SR bit must be set to "1", since it is this bit which generates the Reset signal when it changes to "0"; clearing this bit would generate an immediate Reset.

It should be noted that the order of the bits in the DWDR register is inverted with respect to the associated bits in the down counter: bit 7 of the DWDR register corresponds, in fact, to T0 and bit 2 to T5. The user should bear in mind the fact that these bits are inverted and shifted with respect to the physical counter bits when writing to this register. The relationship between the DWDR register bits and the physical implementation of the Watchdog timer downcounter is illustrated in [Figure 13](#).

Only the 6 most significant bits may be used to define the time period, since it is bit 6 which triggers the Reset when it changes to "0". This offers the user a choice of 64 timed periods ranging from 3,072 to 196,608 clock cycles (with an oscillator frequency of 8MHz, this is equivalent to timer periods ranging from 384µs to 24.576ms).

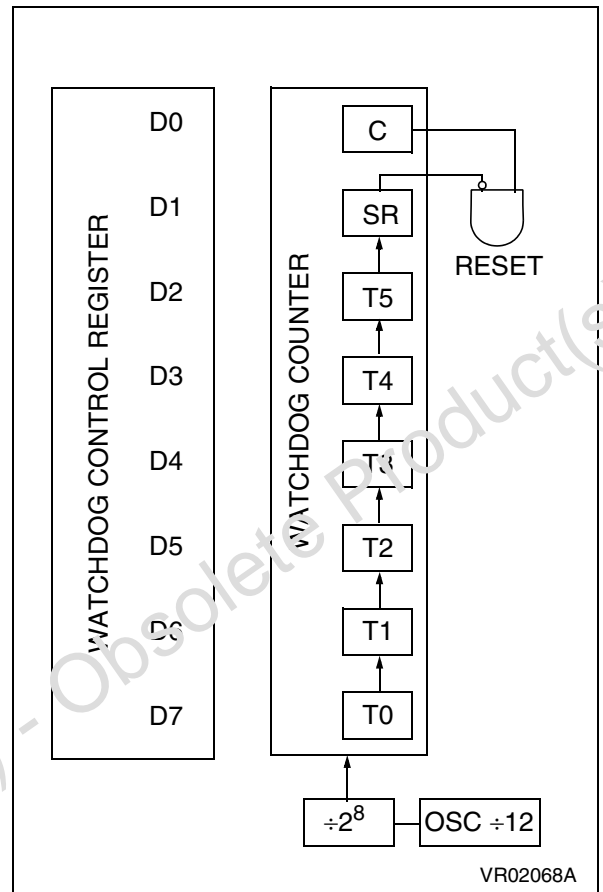
**Figure 13. Watchdog Counter Control**

**DIGITAL WATCHDOG** (Cont'd)**3.3.1 Digital Watchdog Register (DWDR)**

Address: 0D8h — Read/Write

Reset status: 1111 1110b

7								0
T0	T1	T2	T3	T4	T5	SR	C	

Bit 0 = **C**: *Watchdog Control bit*

If the hardware option is selected, this bit is forced high and the user cannot change it (the Watchdog is always active). When the software option is selected, the Watchdog function is activated by setting bit C to 1, and cannot then be disabled (save by resetting the MCU).

When C is kept low the counter can be used as a 7-bit timer.

This bit is cleared to "0" on Reset.

Bit 1 = **SR**: *Software Reset bit*

This bit triggers a Reset when cleared.

When C = "0" (Watchdog disabled) it is the MSB of the 7-bit timer.

This bit is set to "1" on Reset.

Bits 2-7 = **T5-T0**: *Downcounter bits*

It should be noted that the register bits are reversed and shifted with respect to the physical counter: bit-7 (T0) is the LSB of the Watchdog downcounter and bit-2 (T5) is the MSB.

These bits are set to "1" on Reset.

**3.3.2 Application Notes**

The Watchdog plays an important supporting role in the high noise immunity of ST62xx devices, and should be used wherever possible. Watchdog related options should be selected on the basis of a trade-off between application security and STOP mode availability.

When STOP mode is not required, hardware activation should be preferred, as it provides maximum security, especially during power-on.

When software activation is selected and the Watchdog is not activated, the downcounter may be used as a simple 7-bit timer (remember that the bits are in reverse order).

The software activation option should be chosen only when the Watchdog counter is to be used as a timer. To ensure the Watchdog has not been unexpectedly activated, the following instructions should be executed within the first 27 instructions:

```
jrr 0, WD, #+3
```

**DIGITAL WATCHDOG (Cont'd)**

These instructions test the C bit and Reset the MCU (i.e. disable the Watchdog) if the bit is set (i.e. if the Watchdog is active), thus disabling the Watchdog.

In all modes, a minimum of 28 instructions are executed after activation, before the Watchdog can generate a Reset. Consequently, user software

should load the watchdog counter within the first 27 instructions following Watchdog activation (software mode), or within the first 27 instructions executed following a Reset (hardware activation).

It should be noted that when the GEN bit is low (interrupts disabled), the NMI interrupt is active but cannot cause a wake up from STOP/WAIT modes.

**Figure 14. Digital Watchdog Block Diagram**

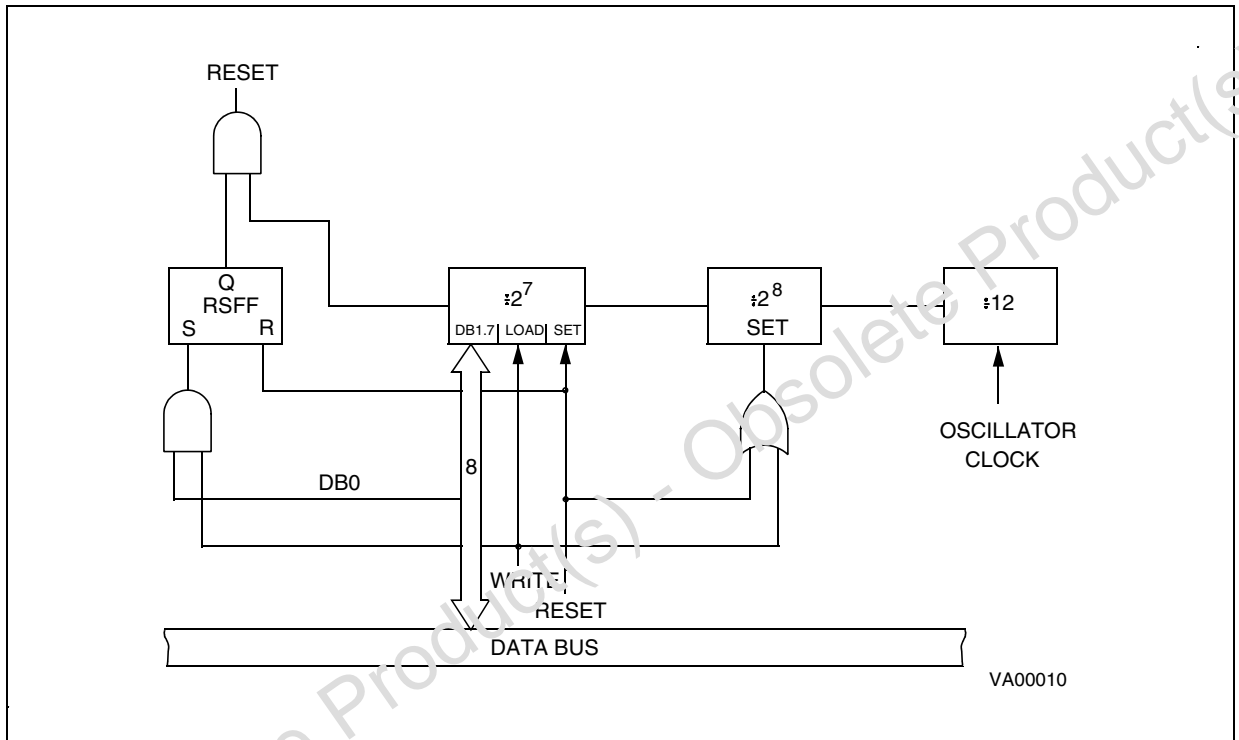

### 3.4 INTERRUPTS

The CPU can manage four Maskable Interrupt sources, in addition to a Non Maskable Interrupt source (top priority interrupt). Each source is associated with a specific Interrupt Vector which contains a Jump instruction to the associated interrupt service routine. These vectors are located in Program space (see [Table 10](#)).

When an interrupt source generates an interrupt request, and interrupt processing is enabled, the PC register is loaded with the address of the interrupt vector (i.e. of the Jump instruction), which then causes a Jump to the relevant interrupt service routine, thus servicing the interrupt.

Interrupt sources are linked to events either on external pins, or on chip peripherals. Several events can be ORed on the same interrupt source, and relevant flags are available to determine which event triggered the interrupt.

The Non Maskable Interrupt request has the highest priority and can interrupt any interrupt routine at any time; the other four interrupts cannot interrupt each other. If more than one interrupt request is pending, these are processed by the processor core according to their priority level: source #1 has the higher priority while source #4 the lower. The priority of each interrupt source is fixed.

**Table 10. Interrupt Vector Map**

Interrupt Source	Priority	Vector Address
Interrupt source #0	1	(FF0h-FF0h)
Interrupt source #1	2	(FF6h-FF7h)
Interrupt source #2	3	(FF4h-FF5h)
Interrupt source #3	4	(FF2h-FF3h)
Interrupt source #4	5	(FF0h-FF1h)

#### 3.4.1 Interrupt request

All interrupt sources but the Non Maskable Interrupt source can be disabled by setting accordingly the GEN bit of the Interrupt Option Register (IOR). This GEN bit also defines if an interrupt source, including the Non Maskable Interrupt source, can restart the MCU from STOP/WAIT modes.

Interrupt request from the Non Maskable Interrupt source #0 is latched by a flip flop which is automati-

cally reset by the core at the beginning of the non-maskable interrupt service routine.

Interrupt request from source #1 can be configured either as edge or level sensitive by setting accordingly the LES bit of the Interrupt Option Register (IOR).

Interrupt request from source #2 are always edge sensitive. The edge polarity can be configured by setting accordingly the ESB bit of the Interrupt Option Register (IOR).

Interrupt request from sources #3 & #4 are level sensitive.

In edge sensitive mode, a latch is set when a edge occurs on the interrupt source line and is cleared when the associated interrupt routine is started. So, the occurrence of an interrupt can be stored, until completion of the running interrupt routine before being processed. If several interrupt requests occurs before completion of the running interrupt routine, only the first request is stored.

Storage of interrupt requests is not available in level sensitive mode. To be taken into account, the low level must be present on the interrupt pin when the MCU samples the line after instruction execution.

At the end of every instruction, the MCU tests the interrupt lines: if there is an interrupt request the next instruction is not executed and the appropriate interrupt service routine is executed instead.

**Table 11. Interrupt Option Register Description**

GEN	SET	Enable all interrupts
	CLEARED	Disable all interrupts
ESB	SET	Rising edge mode on interrupt source #2
	CLEARED	Falling edge mode on interrupt source #2
LES	SET	Level-sensitive mode on interrupt source #1
	CLEARED	Falling edge mode on interrupt source #1
OTHERS	NOT USED	

**INTERRUPTS (Cont'd)**

**3.4.2 Interrupt Procedure**

The interrupt procedure is very similar to a call procedure, indeed the user can consider the interrupt as an asynchronous call procedure. As this is an asynchronous event, the user cannot know the context and the time at which it occurred. As a result, the user should save all Data space registers which may be used within the interrupt routines. There are separate sets of processor flags for normal, interrupt and non-maskable interrupt modes, which are automatically switched and so do not need to be saved.

The following list summarizes the interrupt procedure:

**MCU**

- The interrupt is detected.
- The C and Z flags are replaced by the interrupt flags (or by the NMI flags).
- The PC contents are stored in the first level of the stack.
- The normal interrupt lines are inhibited (NMI still active).
- The first internal latch is cleared.
- The associated interrupt vector is loaded in the PC.

**WARNING:** In some circumstances, when a maskable interrupt occurs while the ST6 core is in NORMAL mode and especially during the execution of an "Idi IOR, 00h" instruction (disabling all maskable interrupts): if the interrupt arrives during the first 3 cycles of the "Idi" instruction (which is a 4-cycle instruction) the core will switch to interrupt mode BUT the flags CN and ZN will NOT switch to the interrupt pair CI and ZI.

**User**

- User selected registers are saved within the interrupt service routine (normally on a software stack).
- The source of the interrupt is found by polling the interrupt flags (if more than one source is associated with the same vector).
- The interrupt is serviced.
- Return from interrupt (RETI)

**MCU**

- Automatically the MCU switches back to the normal flag set (or the interrupt flag set) and pops the previous PC value from the stack.

The interrupt routine usually begins by the identifying the device which generated the interrupt request (by polling). The user should save the registers which are used within the interrupt routine in a software stack. After the RETI instruction is executed, the MCU returns to the main routine.

**Figure 15. Interrupt Processing Flow Chart**

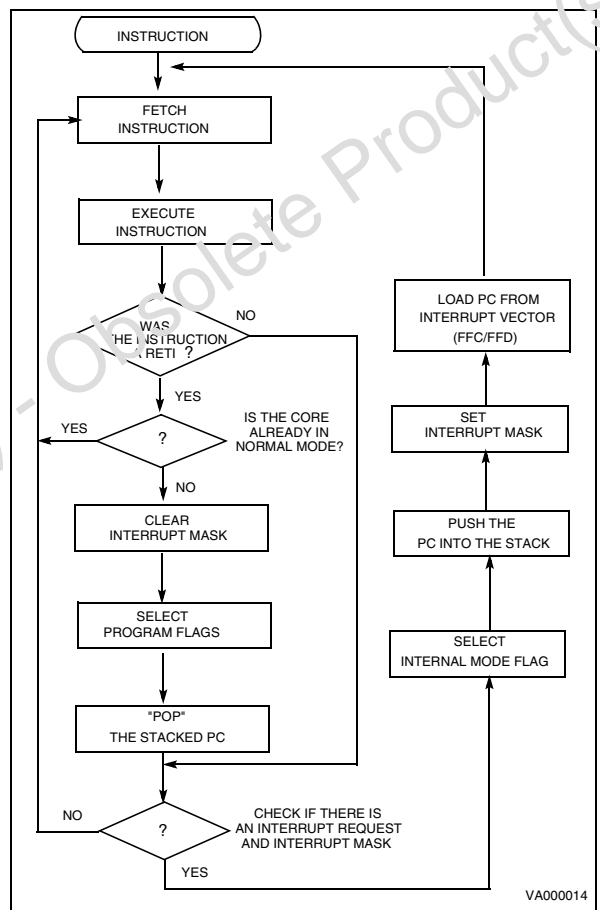

**INTERRUPTS** (Cont'd)**3.4.3 Interrupt Option Register (IOR)**

The Interrupt Option Register (IOR) is used to enable/disable the individual interrupt sources and to select the operating mode of the external interrupt inputs. This register is write-only and cannot be accessed by single-bit operations.

Address: 0C8h — Write Only

Reset status: 00h

7	-	LES	ESB	GEN	-	-	-	0
---	---	-----	-----	-----	---	---	---	---

Bit 7, Bits 3-0 = *Unused*.

Bit 6 = **LES**: *Level/Edge Selection bit*.

When this bit is set to one, the interrupt source #1 is level sensitive. When cleared to zero the edge sensitive mode for interrupt request is selected.

**Table 12. Interrupt Requests and Mask Bits**

Peripheral	Register	Address Register	Mask bit	Masked Interrupt Source	Interrupt source
GENERAL	IOR	C8h	GEN	All Interrupts, excluding NMI	All
TIMER 1	TSCR1	D4h	ETI	TMZ: TIMER Overflow	source 3
TIMER 2	TSCR2	D7h			
A/D CONVERTER	ADCR	D1h	EAI	EOC: End of Conversion	source 4
SPI	SPI	C2h	ALL	End of Transmission	source 1
Port PAn	ORPA-DRPA	C0h-C4h	ORPAn-DRPAn	PAn pin	source 2
Port PBn	ORPB-DRPB	C7h-C5h	ORPBn-DRPBn	PBn pin	source 2
Port PCn	ORPC-DRPC	C6h-CFh	ORPCn-DRPCn	PCn pin	source 2

Bit 5 = **ESB**: *Edge Selection bit*.

The bit ESB selects the polarity of the interrupt source #2.

Bit 4 = **GEN**: *Global Enable Interrupt*. When this bit is set to one, all interrupts are enabled. When this bit is cleared to zero all the interrupts (excluding NMI) are disabled.

When the GEN bit is low, the NMI interrupt is active but cannot cause a wake up from STOP/WAIT modes.

This register is cleared on reset.

**3.4.4 Interrupt Sources**

Interrupt sources available on the ST62E42B/T42B are summarized in the [Table 12](#) with associated mask bit to enable/disable the interrupt request.

INTERRUPTS (Cont'd)

Figure 16. Interrupt Block Diagram

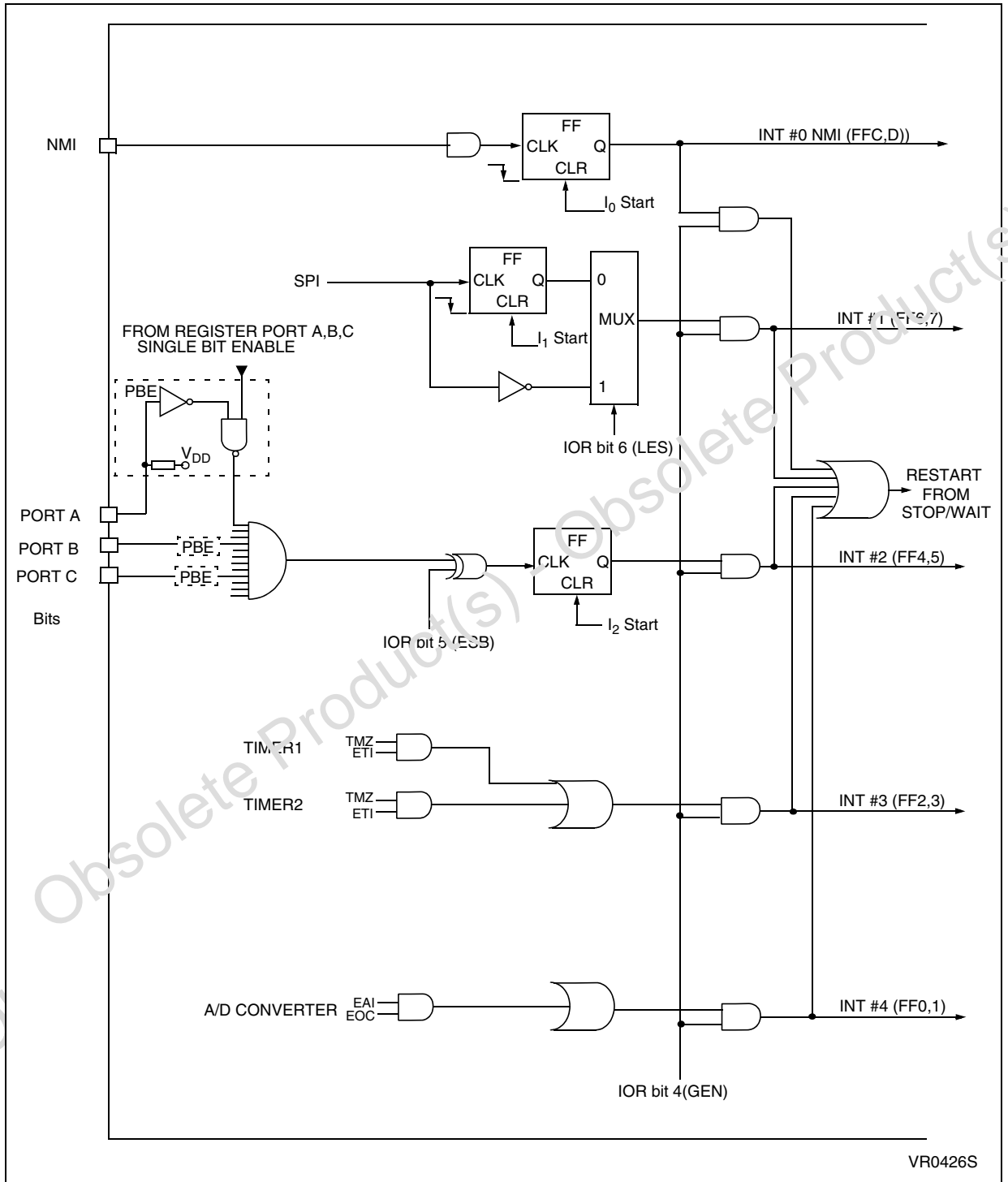

### 3.5 POWER SAVING MODES

The WAIT and STOP modes have been implemented in the ST62xx family of MCUs in order to reduce the product's electrical consumption during idle periods. These two power saving modes are described in the following paragraphs.

#### 3.5.1 WAIT Mode

The MCU goes into WAIT mode as soon as the WAIT instruction is executed. The microcontroller can be considered as being in a "software frozen" state where the core stops processing the program instructions, the RAM contents and peripheral registers are preserved as long as the power supply voltage is higher than the RAM retention voltage. In this mode the peripherals are still active.

WAIT mode can be used when the user wants to reduce the MCU power consumption during idle periods, while not losing track of time or the capability of monitoring external events. The active oscillator is not stopped in order to provide a clock signal to the peripherals. Timer counting may be enabled as well as the Timer interrupt, before entering the WAIT mode: this allows the WAIT mode to be exited when a Timer interrupt occurs. The same applies to other peripherals which use the clock signal.

If the WAIT mode is exited due to a Reset (either by activating the external pin or generated by the Watchdog), the MCU enters a normal reset procedure. If an interrupt is generated during WAIT mode, the MCU's behaviour depends on the state

of the processor core prior to the WAIT instruction, but also on the kind of interrupt request which is generated. This is described in the following paragraphs. The processor core does not generate a delay following the occurrence of the interrupt, because the oscillator clock is still available and no stabilisation period is necessary.

#### 3.5.2 STOP Mode

If the Watchdog is disabled, STOP mode is available. When in STOP mode, the MCU is placed in the lowest power consumption mode. In this operating mode, the microcontroller can be considered as being "frozen", no instruction is executed, the oscillator is stopped, the RAM contents and peripheral registers are preserved as long as the power supply voltage is higher than the RAM retention voltage, and the ST62xx core waits for the occurrence of an external interrupt request or a Reset to exit the STOP state.

If the STOP state is exited due to a Reset (by activating the external pin) the MCU will enter a normal reset procedure. Behaviour in response to interrupts depends on the state of the processor core prior to issuing the STOP instruction, and also on the kind of interrupt request that is generated.

This case will be described in the following paragraphs. The processor core generates a delay after occurrence of the interrupt request, in order to wait for complete stabilisation of the oscillator, before executing the first instruction.

**POWER SAVING MODE (Cont'd)****3.5.3 Exit from WAIT and STOP Modes**

The following paragraphs describe how the MCU exits from WAIT and STOP modes, when an interrupt occurs (not a Reset). It should be noted that the restart sequence depends on the original state of the MCU (normal, interrupt or non-maskable interrupt mode) prior to entering WAIT or STOP mode, as well as on the interrupt type.

Interrupts do not affect the oscillator selection.

**3.5.3.1 Normal Mode**

If the MCU was in the main routine when the WAIT or STOP instruction was executed, exit from Stop or Wait mode will occur as soon as an interrupt occurs; the related interrupt routine is executed and, on completion, the instruction which follows the STOP or WAIT instruction is then executed, providing no other interrupts are pending.

**3.5.3.2 Non Maskable Interrupt Mode**

If the STOP or WAIT instruction has been executed during execution of the non-maskable interrupt routine, the MCU exits from the Stop or Wait mode as soon as an interrupt occurs: the instruction which follows the STOP or WAIT instruction is executed, and the MCU remains in non-maskable interrupt mode, even if another interrupt has been generated.

**3.5.3.3 Normal Interrupt Mode**

If the MCU was in interrupt mode before the STOP or WAIT instruction was executed, it exits from STOP or WAIT mode as soon as an interrupt occurs. Nevertheless, two cases must be considered:

- If the interrupt is a normal one, the interrupt routine in which the WAIT or STOP mode was entered

will be completed, starting with the execution of the instruction which follows the STOP or the WAIT instruction, and the MCU is still in the interrupt mode. At the end of this routine pending interrupts will be serviced in accordance with their priority.

- In the event of a non-maskable interrupt, the non-maskable interrupt service routine is processed first, then the routine in which the WAIT or STOP mode was entered will be completed by executing the instruction following the STOP or WAIT instruction. The MCU remains in normal interrupt mode.

**Notes:**

*To achieve the lowest power consumption during RUN or WAIT modes, the user program must take care of:*

- configuring unused I/Os as inputs without pull-up (these should be externally tied to well defined logic levels);
- placing all peripherals in their power down modes before entering STOP mode;

When the hardware activated Watchdog is selected, or when the software Watchdog is enabled, the STOP instruction is disabled and a WAIT instruction will be executed in its place.

If all interrupt sources are disabled (GEN low), the MCU can only be restarted by a Reset. Although setting GEN low does not mask the NMI as an interrupt, it will stop it generating a wake-up signal.

The WAIT and STOP instructions are not executed if an enabled interrupt request is pending.

## 4 ON-CHIP PERIPHERALS

### 4.1 I/O PORTS

The MCU features Input/Output lines which may be individually programmed as any of the following input or output configurations:

- Input without pull-up or interrupt
- Input with pull-up and interrupt
- Input with pull-up, but without interrupt
- Analog input
- Push-pull output
- Open drain output

The lines are organised as bitwise Ports.

Each port is associated with 3 registers in Data space. Each bit of these registers is associated with a particular line (for instance, bits 0 of Port A Data, Direction and Option registers are associated with the PA0 line of Port A).

The DATA registers (DRx), are used to read the voltage level values of the lines which have been configured as inputs, or to write the logic value of the signal to be output on the lines configured as outputs. The port data registers can be read to get the effective logic levels of the pins, but they can

be also written by user software, in conjunction with the related option registers, to select the different input mode options.

Single-bit operations on I/O registers are possible but care is necessary because reading in input mode is done from I/O pins while writing will directly affect the Port data register causing an undesired change of the input configuration.

The Data Direction registers (DDRx) allow the data direction (input or output) of each pin to be set.

The Option registers (ORx) are used to select the different port options available both in input and in output mode.

All I/O registers can be read or written to just as any other RAM location in Data space, so no extra RAM cells are needed for port data storage and manipulation. During MCU initialization, all I/O registers are cleared and the input mode with pull-ups and no interrupt generation is selected for all the pins, thus avoiding pin conflicts.

Figure 17. I/O Port Block Diagram

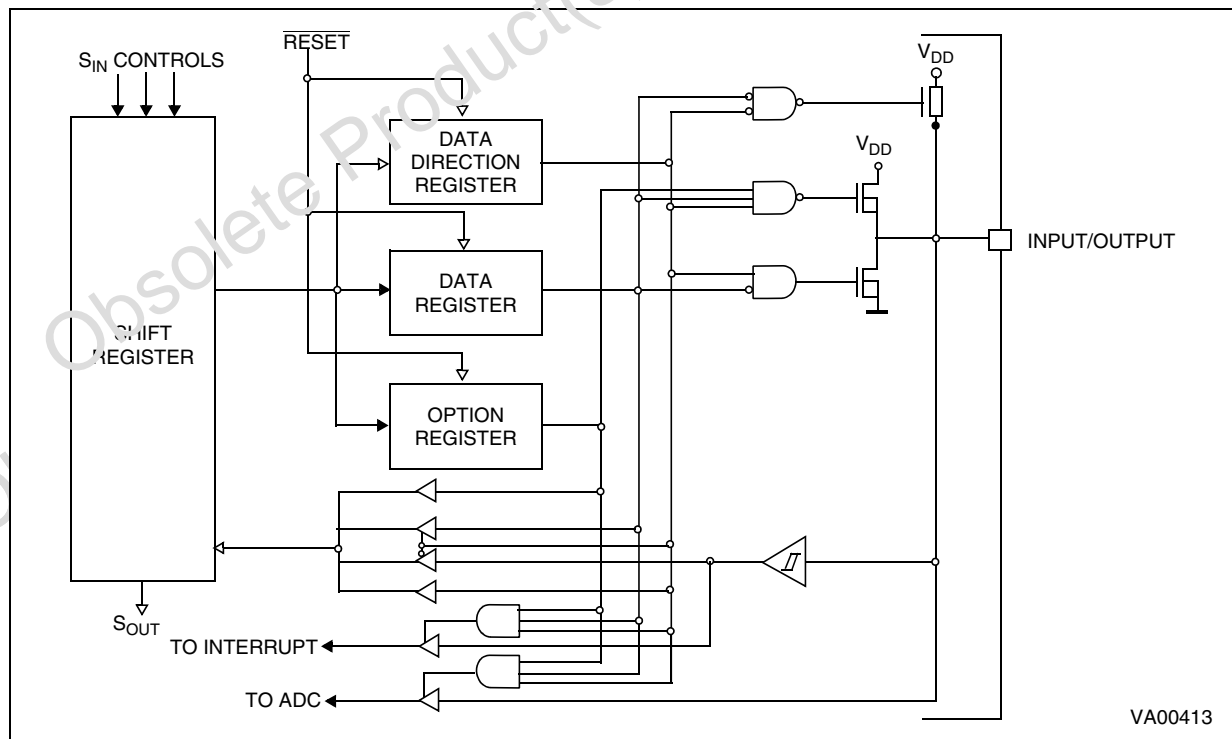

**I/O PORTS** (Cont'd)**4.1.1 Operating Modes**

Each pin may be individually programmed as input or output with various configurations.

This is achieved by writing the relevant bit in the Data (DR), Data Direction (DDR) and Option registers (OR). [Table 13](#) illustrates the various port configurations which can be selected by user software.

**4.1.1.1 Input Options**

Pull-up, High Impedance Option. All input lines can be individually programmed with or without an internal pull-up by programming the OR and DR registers accordingly. If the pull-up option is not selected, the input pin will be in the high-impedance state.

**4.1.1.2 Interrupt Options**

All input lines can be individually connected by software to the interrupt system by programming the OR and DR registers accordingly. The interrupt trigger modes (falling edge, rising edge and low level) can be configured by software as described in the Interrupt Chapter for each port.

**4.1.1.3 Analog Input Options**

Some pins can be configured as analog inputs by programming the OR and DR registers accordingly. These analog inputs are connected to the on-chip 8-bit Analog to Digital Converter. *ONLY ONE* pin should be programmed as an analog input at any time, since by selecting more than one input simultaneously their pins will be effectively shorted.

**Table 13. I/O Port Option Selection**

DDR	OR	DR	Mode	Option
0	0	0	Input	With pull-up, no interrupt
0	0	1	Input	No pull-up, no interrupt
0	1	0	Input	With pull-up and with interrupt
0	1	1	Input	Analog input (when available)
1	0	X	Output	Open-drain output (20mA sink when available)
1	1	X	Output	Push-pull output (20mA sink when available)

**Note:** X = Don't care

## I/O PORTS (Cont'd)

### 4.1.2 Safe I/O State Switching Sequence

Switching the I/O ports from one state to another should be done in a sequence which ensures that no unwanted side effects can occur. The recommended safe transitions are illustrated in Figure 18. All other transitions are potentially risky and should be avoided when changing the I/O operating mode, as it is most likely that undesirable side-effects will be experienced, such as spurious interrupt generation or two pins shorted together by the analog multiplexer.

Single bit instructions (SET, RES, INC and DEC) should be used with great caution on Ports Data registers, since these instructions make an implicit read and write back of the entire register. In port input mode, however, the data register reads from the input pins directly, and not from the data register latches. Since data register information in input mode is used to set the characteristics of the input pin (interrupt, pull-up, analog input), these may be unintentionally reprogrammed depending on the state of the input pins. As a general rule, it is better to limit the use of single bit instructions on data registers to when the whole (8-bit) port is in output mode. In the case of inputs or of mixed inputs and

outputs, it is advisable to keep a copy of the data register in RAM. Single bit instructions may then be used on the RAM copy, after which the whole copy register can be written to the port data register:

```
SET bit, datacopy
LD a, datacopy
LD DRA, a
```

**Warning:** Care must also be taken to not use instructions that act on a whole port register (INC, DEC, or read operations) when all 8 bits are not available on the device. Unavailable bits must be masked by software (AND instruction).

The WAIT and STOP instructions allow the ST62xx to be used in situations where low power consumption is needed. The lowest power consumption is achieved by configuring I/Os in input mode with well-defined logic levels.

The user must take care not to switch outputs with heavy loads during the conversion of one of the analog inputs in order to avoid any disturbance to the conversion.

Figure 18. Diagram showing Safe I/O State Transitions

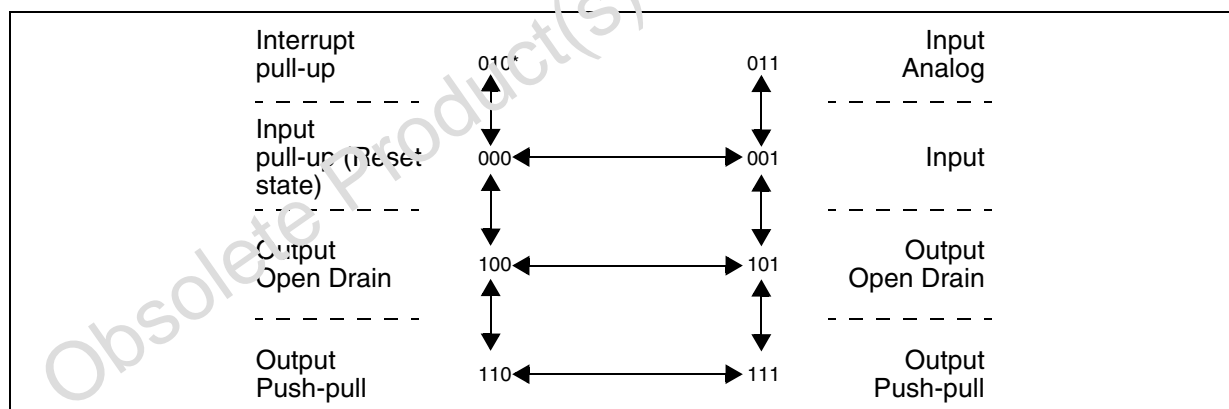

Note \*. xxx = DDR, OR, DR Bits respectively

I/O PORTS (Cont'd)

Table 14. I/O Port configuration for the ST62T42B/E42B

MODE	AVAILABLE ON <sup>(1)</sup>	SCHEMATIC
Input	PA4-PA7 PB2-PB7 PC0-PC7	
Input with pull up (Reset state except for PC0-PC7)	PA4-PA7 PB2-PB7 PC0-PC7	
Input with pull up with interrupt	PA4-PA7 PB2-PB7 PC0-PC7	
Analog Input	PA4-PA7 PB2-PB3	
Open drain output 5mA  Open drain output 20mA	PA4-PA7 PB2-PB7 PC0-PC7 (1mA)  PB4-PB7	
Push-pull output 5mA  Push-pull output 20mA	PA4-PA7 PB2-PB7 PC0-PC7 (1mA)  PB4-PB7	

Note 1. Provided the correct configuration has been selected.

## I/O PORTS (Cont'd)

### 4.1.3 LCD alternate functions (combiports)

PC0 to PC7 can also be individually defined as 8 LCD segment output by setting DDRC, ORC and DRC registers as shown in Table 15.

On the contrary with other I/O lines, the reset state is the LCD output mode. These 8 segment lines are recognised as S33..S40 by the embedded LCD controller drive.

### 4.1.4 SPI alternate functions

PB6/Sin and PB5/Scl pins must be configured as input through the DDR and OR registers to be used data in and data clock (Slave mode) for the SPI. All input modes are available and I/O's can be read independantly of the SPI at any time.

PB7/Sout must be configured in open drain output mode to be used as data out for the SPI. In output mode, the value present on the pin is the port data register content only if PB7 is defined as push pull output, while serial transmission is possible only in open drain mode.

**Table 15. PC0-PC7 Combiport Option Selection**

DDR	OR	DR	Mode	Option
0	0	0	Input	With pull-up, no interrupt
0	0	1	Input	No pull-up, no interrupt
0	1	0	Input	With pull-up and with interrupt
0	1	1	Input	LCD segment (Reset state)
1	0	X	Output	Open-drain output
1	1	X	Output	Push-pull output

Note: X = Don't care

**Figure 19. Peripheral Interface Configuration of SPI**

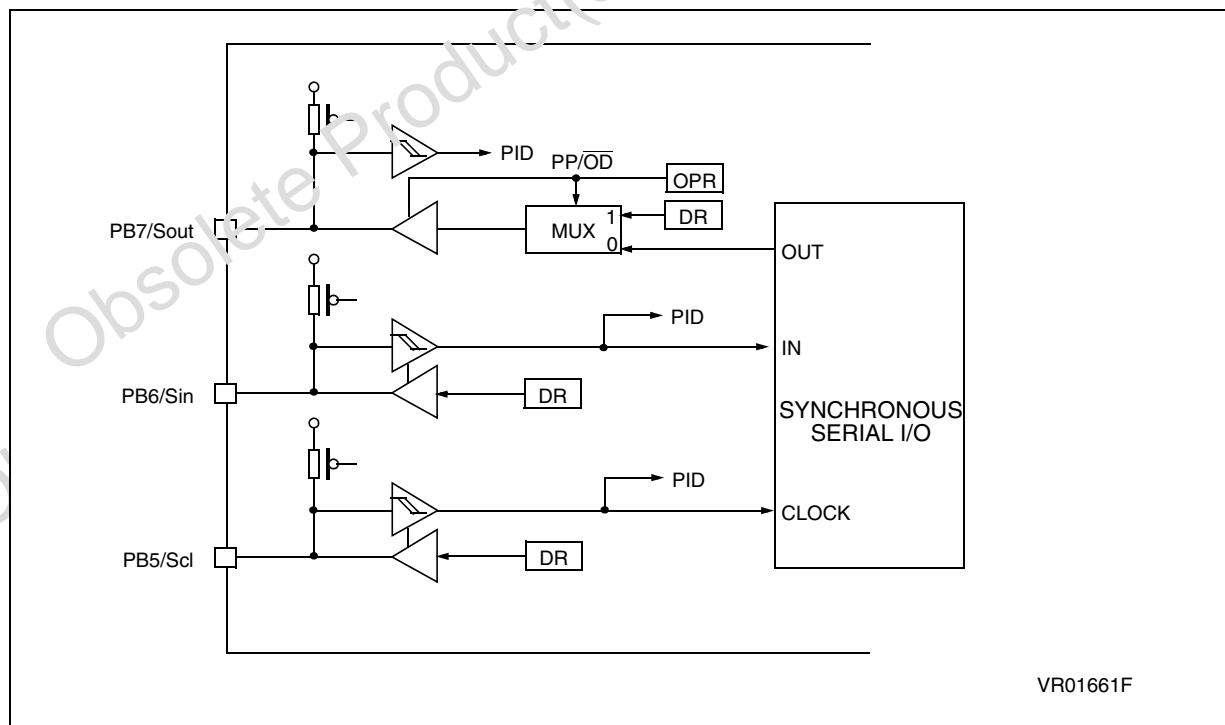

I/O PORTS (Cont'd)

4.1.5 I/O Port Option Registers

ORA/B/C (CCh PA, CEh PB, CFh PC)

Read/Write

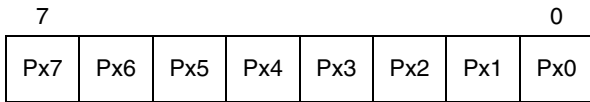

Bit 7-0 = **Px7 - Px0**: Port A, B, C Option Register bits.

4.1.6 I/O Port Data Direction Registers

DDRA/B/C (C4h PA, C5h PB, C6h PC)

Read/Write

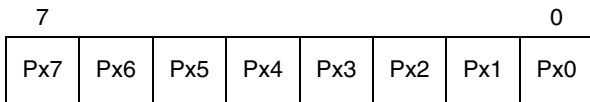

Bit 7-0 = **Px7 - Px0**: Port A, B, C Data Direction Registers bits.

4.1.7 I/O Port Data Registers

DRA/B/C (C0h PA, C1h PB, C3h PC)

Read/Write

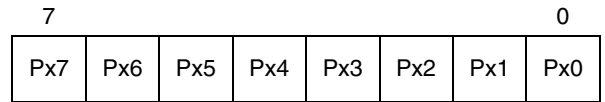

Bit 7-0 = **Px7 - Px0**: Port A, B, C Data Registers bits.

## 4.2 TIMER 1 & 2

The MCU features two on-chip Timer peripheral named TIMER 1 & TIMER 2. Each of these timers consist of an 8-bit counter with a 7-bit programmable prescaler, giving a maximum count of  $2^{15}$ .

The content of the 8-bit counter can be read/written in the Timer/Counter register, TCR, while the state of the 7-bit prescaler can be read in the PSC register. The control logic device is managed in the TSCR register as described in the following paragraphs.

The 8-bit counter is decremented by the output (rising edge) coming from the 7-bit prescaler and can be loaded and read under program control. When it decrements to zero then the TMZ (Timer Zero) bit in the TSCR is set to "1". If the ETI (Enable Timer Interrupt) bit in the TSCR is also set to "1", an interrupt request is generated as described in the Interrupt Chapter. The Timer interrupt can be used to exit the MCU from WAIT mode.

The prescaler input is the internal frequency  $f_{INT}$  divided by 12 (TIMER 1 & 2). The prescaler decre-

ments on the rising edge. Depending on the division factor programmed by PS2, PS1 and PS0 bits in the TSCR. The clock input of the timer/counter register is multiplexed to different sources. For division factor 1, the clock input of the prescaler is also that of timer/counter; for factor 2, bit 0 of the prescaler register is connected to the clock input of TCR. This bit changes its state at half the frequency of the prescaler input clock. For factor 4, bit 1 of the PSC is connected to the clock input of TCR, and so forth. The prescaler initialize bit, PSI, in the TSCR register must be set to "1" to allow the prescaler (and hence the counter) to start. If it is cleared to "0", all the prescaler bits are set to "1" and the counter is inhibited from counting. The prescaler can be loaded with any value between 0 and 7Fh, if bit PSI is set to "1". The prescaler tap is selected by means of the PS2/PS1/PS0 bits in the control register.

Figure 20 illustrates the Timer's working principle.

Figure 20. Timer Working Principle

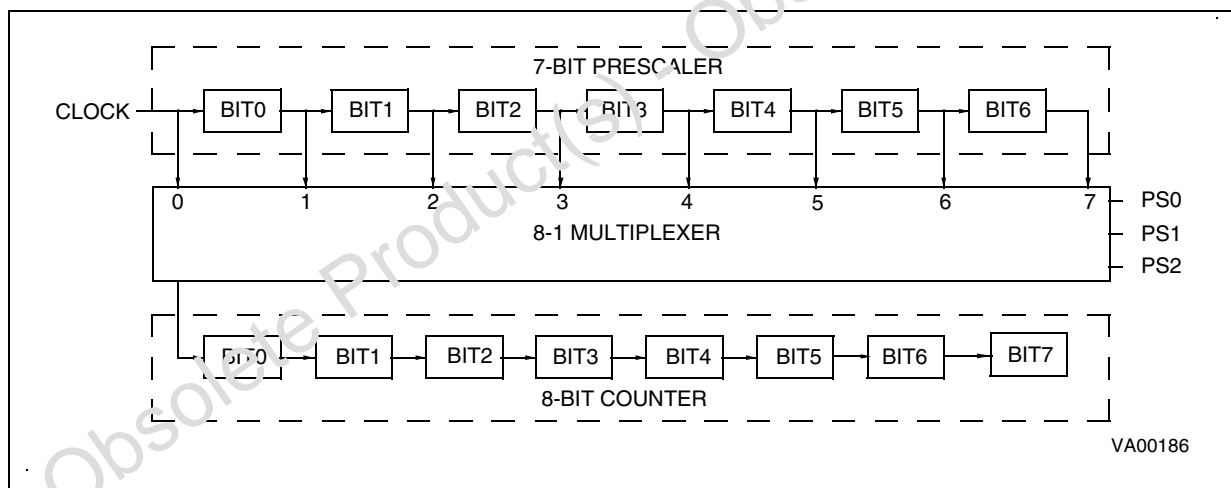
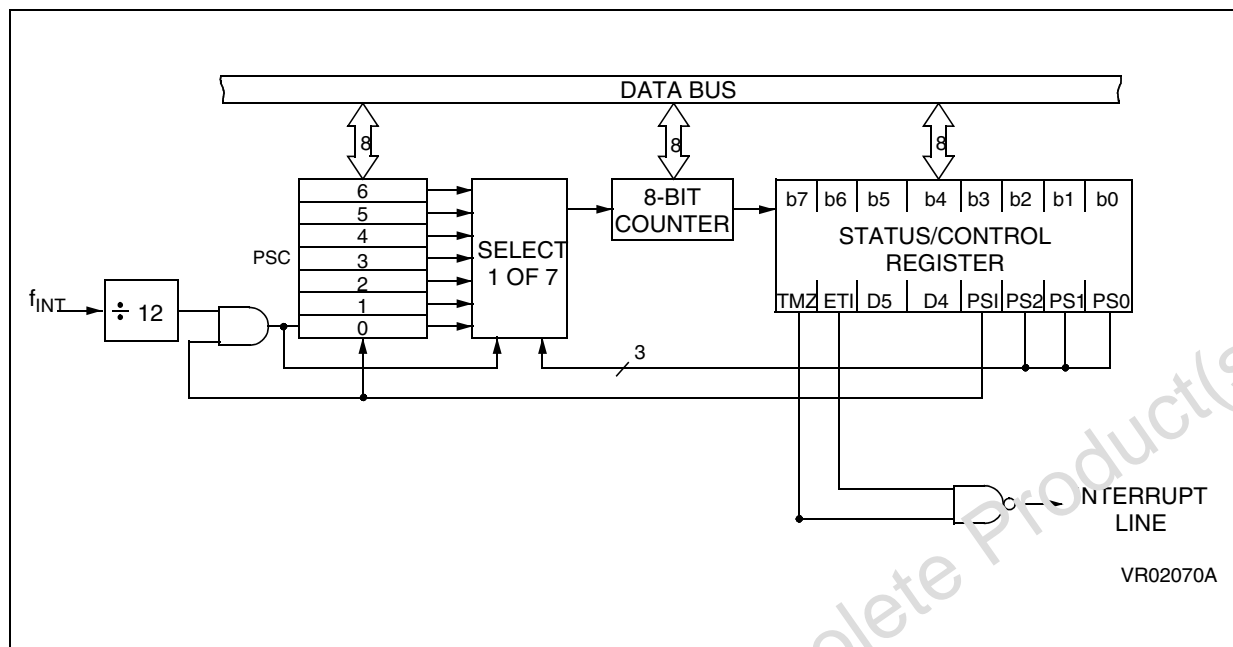

Figure 21. TIMER 1 & 2 Block Diagram



## TIMER 1 & 2 (Cont'd)

### 4.2.1 TIMER 1 & 2 Operating Mode

The Timer prescaler is clocked by the prescaler clock input ( $f_{INT} \div 12$ ).

The user can select for each TIMER the desired prescaler division ratio through the PS2, PS1, PS0 bits. When the TCR count reaches 0, it sets the TMZ bit in the TSCR. The TMZ bit can be tested under program control to perform a timer function whenever it goes high.

### 4.2.2 Timer Interrupt

When one of the counter registers decrements to zero with the associated ETI (Enable Timer Interrupt) bit set to one, an interrupt request is generated as described in Interrupt Chapter. When the counter decrements to zero, the associated TMZ bit in the TSCR register is set to one.

### 4.2.3 Application Notes

TMZ is set when the counter reaches zero; however, it may also be set by writing 00h in the TCR register or by setting bit 7 of the TSCR register. The TMZ bit must be cleared by user software when servicing the timer interrupt to avoid undesired interrupts when leaving the interrupt service routine. After reset, the 8-bit counter register is loaded with 0FFh, while the 7-bit prescaler is loaded with 07Fh, and the TSCR register is cleared. This means that the Timer is stopped (PSI="0") and the timer interrupt is disabled.

A write to the TCR register will predominate over the 8-bit counter decrement to 00h function i.e. if a write and a TCR register decrement to 00h occur simultaneously, the write will take precedence, and the TMZ bit is not set until the 8-bit counter reaches 00h again. The values of the TCR and the PSC registers can be read accurately at any time.

**TIMER 1 & 2 (Cont'd)**

**4.2.4 TIMER 1 Registers**

**Timer Status Control Register (TSCR)**

Address: 0D4h — Read/Write

7							0
TMZ	ETI	-	-	PSI	PS2	PS1	PS0

Bit 7 = **TMZ**: *Timer Zero bit*

A low-to-high transition indicates that the timer count register has decremented to zero. This bit must be cleared by user software before starting a new count.

Bit 6 = **ETI**: *Enable Timer Interrupt*

When set, enables the timer interrupt request. If ETI=0 the timer interrupt is disabled. If ETI=1 and TMZ=1 an interrupt request is generated.

Bit 5 = *Reserved*. Must be set to 1.

Bit 4 = Do not care

Data sent to the timer output when TMZ is set high (output mode only). Input mode selection (input mode only)

Bit 3 = **PSI**: *Prescaler Initialize Bit*

Used to initialize the prescaler and inhibit its counting. When PSI="0" the prescaler is set to 7Fh and the counter is inhibited. When PSI="1" the prescaler is enabled to count downwards. As long as PSI="0" both counter and prescaler are not running.

Bit 2, 1, 0 = **PS2, PS1, PS0**. *Prescaler Mux. Select*. These bits select the division ratio of the prescaler register.

PS2	PS1	PS0	Divided by
0	0	0	1
0	0	1	2
0	1	0	4
0	1	1	8
1	0	0	16
1	0	1	32
1	1	0	64
1	1	1	128

**Timer Counter Register (TCR)**

Address: 0D3h — Read/Write

7							0
D7	D6	D5	D4	D3	D2	D1	D0

Bit 7-0 = **D7-D0**: *Counter Bits*.

**Prescaler Register PSC**

Address: 0D2h — Read/Write

7							0
D7	D6	D5	D4	D3	D2	D1	D0

Bit 7 = **D7**: Always read as "0".

Bit 6-0 = **D6-D0**: Prescaler Bits.

**TIMER 1 & 2 (Cont'd)****4.2.5 TIMER 2 Registers****Timer Status Control Register (TSCR)**

Address: 0D7h — Read/Write

7							0
TMZ	ETI	D5	D4	PSI	PS2	PS1	PS0

Bit 7 = **TMZ**: *Timer Zero bit*

A low-to-high transition indicates that the timer count register has decremented to zero. This bit must be cleared by user software before starting a new count.

Bit 6 = **ETI**: *Enable Timer Interrupt*

When set, enables the timer interrupt request. If ETI=0 the timer interrupt is disabled. If ETI=1 and TMZ=1 an interrupt request is generated.

Bit 5 = **D5**: *Reserved*

Must be set to "1".

Bit 4 = **D4**

Do not care.

Bit 3 = **PSI**: *Prescaler Initialize Bit*

Used to initialize the prescaler and inhibit its counting. When PSI="0" the prescaler is set to 7Fh and the counter is inhibited. When PSI="1" the prescaler is enabled to count downwards. As long as PSI="0" both counter and prescaler are not running.

Bit 2, 1, 0 = **PS2, PS1, PS0**: *Prescaler Mux. Select*. These bits select the division ratio of the prescaler register.

PS2	PS1	PS0	Divided by
0	0	0	1
0	0	1	2
0	1	0	4
0	1	1	8
1	0	0	16
1	0	1	32
1	1	0	64
1	1	1	128

**Timer Counter Register (TCR)**

Address: 0D6h — Read/Write

7							0
D7	D6	D5	D4	D3	D2	D1	D0

Bit 7-0 = **D7-D0**: *Counter Bits*.**Prescaler Register PSC**

Address: 0D5h — Read/Write

7							0
D7	D6	D5	D4	D3	D2	D1	D0

Bit 7 = **D7**: Always read as "0".Bit 6-0 = **D6-D0**: Prescaler Bits.

### 4.3 A/D CONVERTER (ADC)

The A/D converter peripheral is an 8-bit analog to digital converter with analog inputs as alternate I/O functions (the number of which is device dependent), offering 8-bit resolution with a typical conversion time of 70 $\mu$ s (at an oscillator clock frequency of 8MHz).

The ADC converts the input voltage by a process of successive approximations, using a clock frequency derived from the oscillator with a division factor of twelve. With an oscillator clock frequency less than 1.2MHz, conversion accuracy is decreased.

Selection of the input pin is done by configuring the related I/O line as an analog input via the Option and Data registers (refer to I/O ports description for additional information). Only one I/O line must be configured as an analog input at any time. The user must avoid any situation in which more than one I/O pin is selected as an analog input simultaneously, to avoid device malfunction.

The ADC uses two registers in the data space: the ADC data conversion register, ADR, which stores the conversion result, and the ADC control register, ADCR, used to program the ADC functions.

A conversion is started by writing a "1" to the Start bit (STA) in the ADC control register. This automatically clears (resets to "0") the End Of Conversion Bit (EOC). When a conversion is complete, the EOC bit is automatically set to "1", in order to flag that conversion is complete and that the data in the ADC data conversion register is valid. Each conversion has to be separately initiated by writing to the STA bit.

The STA bit is continuously scanned so that, if the user sets it to "1" while a previous conversion is in progress, a new conversion is started before completing the previous one. The start bit (STA) is a write only bit, any attempt to read it will show a logical "0".

The A/D converter features a maskable interrupt associated with the end of conversion. This interrupt is associated with interrupt vector #4 and occurs when the EOC bit is set (i.e. when a conversion is completed). The interrupt is masked using the EAI (interrupt mask) bit in the control register.

The power consumption of the device can be reduced by turning off the ADC peripheral. This is done by setting the PDS bit in the ADC control register to "0". If PDS="1", the A/D is powered and enabled for conversion. This bit must be set at least one instruction before the beginning of the conver-

sion to allow stabilisation of the A/D converter. This action is also needed before entering WAIT mode, since the A/D comparator is not automatically disabled in WAIT mode.

During Reset, any conversion in progress is stopped, the control register is reset to 40h and the ADC interrupt is masked (EAI=0).

Figure 22. ADC Block Diagram

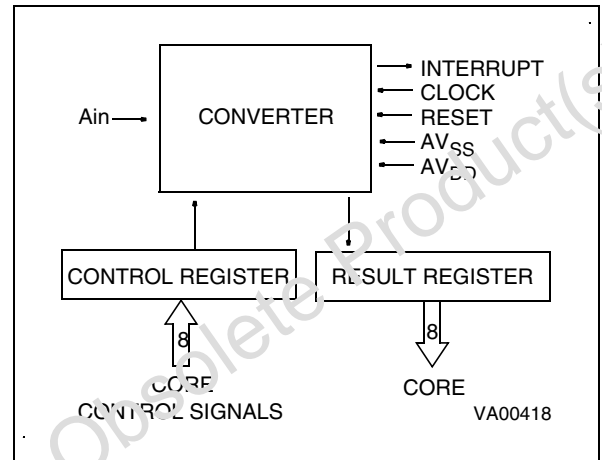

#### 4.3.1 Application Notes

The A/D converter does not feature a sample and hold circuit. The analog voltage to be measured should therefore be stable during the entire conversion cycle. Voltage variation should not exceed  $\pm 1/2$  LSB for the optimum conversion accuracy. A low pass filter may be used at the analog input pins to reduce input voltage variation during conversion.

When selected as an analog channel, the input pin is internally connected to a capacitor  $C_{ad}$  of typically 12pF. For maximum accuracy, this capacitor must be fully charged at the beginning of conversion. In the worst case, conversion starts one instruction (6.5  $\mu$ s) after the channel has been selected. In worst case conditions, the impedance, ASI, of the analog voltage source is calculated using the following formula:

$$6.5\mu\text{s} = 9 \times C_{ad} \times \text{ASI}$$

(capacitor charged to over 99.9%), i.e. 30 k $\Omega$  including a 50% guardband. ASI can be higher if  $C_{ad}$  has been charged for a longer period by adding instructions before the start of conversion (adding more than 26 CPU cycles is pointless).

## A/D CONVERTER (Cont'd)

Since the ADC is on the same chip as the microprocessor, the user should not switch heavily loaded output signals during conversion, if high precision is required. Such switching will affect the supply voltages used as analog references.

The accuracy of the conversion depends on the quality of the power supplies ( $V_{DD}$  and  $V_{SS}$ ). The user must take special care to ensure a well regulated reference voltage is present on the  $V_{DD}$  and  $V_{SS}$  pins (power supply voltage variations must be less than 5V/ms). This implies, in particular, that a suitable decoupling capacitor is used at the  $V_{DD}$  pin.

The converter resolution is given by::

$$\frac{V_{DD} - V_{SS}}{256}$$

*The Input voltage ( $A_{in}$ ) which is to be converted must be constant for  $1\mu s$  before conversion and remain constant during conversion.*

Conversion resolution can be improved if the power supply voltage ( $V_{DD}$ ) to the microcontroller is lowered.

In order to optimise conversion resolution, the user can configure the microcontroller in WAIT mode, because this mode minimises noise disturbances and power supply variations due to output switching. Nevertheless, the WAIT instruction should be executed as soon as possible after the beginning of the conversion, because execution of the WAIT instruction may cause a small variation of the  $V_{DD}$  voltage. The negative effect of this variation is minimized at the beginning of the conversion when the converter is less sensitive, rather than at the end of conversion, when the less significant bits are determined.

The best configuration, from an accuracy standpoint, is WAIT mode with the Timer stopped. Indeed, only the ADC peripheral and the oscillator are then still working. The MCU must be woken up from WAIT mode by the ADC interrupt at the end of the conversion. It should be noted that waking

up the microcontroller could also be done using the Timer interrupt, but in this case the Timer will be working and the resulting noise could affect conversion accuracy.

### A/D Converter Control Register (ADCR)

Address: 0D1h — Read/Write

7							0
EAI	EOC	STA	PDS	D3	D2	D1	D0

Bit 7 = **EAI**: *Enable A/D Interrupt*. If this bit is set to "1" the A/D interrupt is enabled, when EAI=0 the interrupt is disabled.

Bit 6 = **EOC**: *End of conversion. Read Only*. This read only bit indicates when a conversion has been completed. This bit is automatically reset to "0" when the STA bit is written. If the user is using the interrupt option then this bit can be used as an interrupt pending bit. Data in the data conversion register are valid only when this bit is set to "1".

Bit 5 = **STA**: *Start of Conversion. Write Only*. Writing a "1" to this bit will start a conversion on the selected channel and automatically reset to "0" the EOC bit. If the bit is set again when a conversion is in progress, the present conversion is stopped and a new one will take place. This bit is write only, any attempt to read it will show a logical zero.

Bit 4 = **PDS**: *Power Down Selection*. This bit activates the A/D converter if set to "1". Writing a "0" to this bit will put the ADC in power down mode (idle mode).

Bit 3-0 = **D3-D0**. Not used

### A/D Converter Data Register (ADR)

Address: 0D0h — Read only

7							0
D7	D6	D5	D4	D3	D2	D1	D0

Bit 7-0 = **D7-D0**: *8 Bit A/D Conversion Result*.

### 4.4 SERIAL PERIPHERAL INTERFACE (SPI)

The on-chip SPI is an optimized serial synchronous interface that supports a wide range of industry standard SPI specifications. The on-chip SPI is controlled by small and simple user software to perform serial data exchange. The serial shift clock can be implemented either by software (using the bit-set and bit-reset instructions), with the on-chip Timer 1 by externally connecting the SPI clock pin to the timer pin or by directly applying an external clock to the Scl line.

The peripheral is composed by an 8-bit Data/shift Register and a 4-bit binary counter while the Sin pin is the serial shift input and Sout is the serial shift output. These two lines can be tied together to implement two wires protocols (I<sup>2</sup>C-bus, etc). When data is serialized, the MSB is the first bit. Sin has to be programmed as input. For serial output

operation Sout has to be programmed as open-drain output.

The SCL, Sin and Sout SPI clock and data signals are connected to 3 I/O lines on the same external pins. With these 3 lines, the SPI can operate in the following operating modes: Software SPI, S-BUS, I<sup>2</sup>C-bus and as a standard serial I/O (clock, data, enable). An interrupt request can be generated after eight clock pulses. Figure 23 shows the SPI block diagram.

The SCL line clocks, on the falling edge, the shift register and the counter. To allow SPI operation in slave mode, the SCL pin must be programmed as input and an external clock must be supplied to this pin to drive the SPI peripheral.

In master mode, SCL is programmed as output, a clock signal must be generated by software to set and reset the port line.

Figure 23. SPI Block Diagram

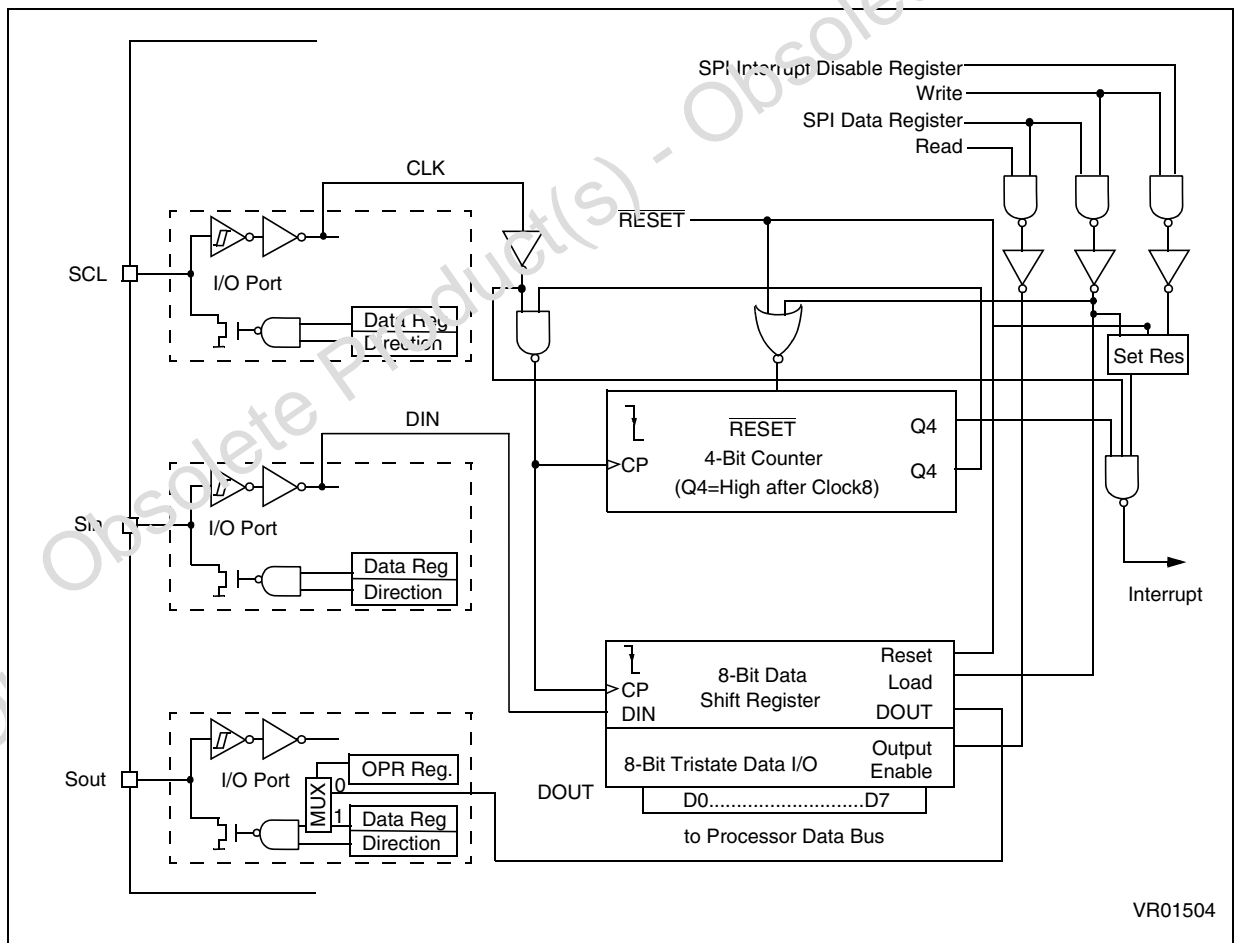

VR01504

## SERIAL PERIPHERAL INTERFACE (Cont'd)

After 8 clock pulses (D7..D0) the output Q4 of the 4-bit binary counter becomes low, disabling the clock from the counter and the data/shift register. Q4 enables the clock to generate an interrupt on the 8th clock falling edge as long as no reset of the counter (processor write into the 8-bit data/shift register) takes place. After a processor reset the interrupt is disabled. The interrupt is active when writing data in the shift register and deactivated when writing any data in the SPI Interrupt Disable register.

The generation of an interrupt to the Core provides information that new data is available (input mode) or that transmission is completed (output mode), allowing the Core to generate an acknowledge on the 9th clock pulse (I<sup>2</sup>C-bus).

The interrupt is initiated by a high to low transition, and therefore interrupt options must be set accordingly as defined in the interrupt section.

After power on reset, or after writing the data/shift register, the counter is reset to zero and the clock is enabled. In this condition the data shift register is ready for reception. No start condition has to be detected. Through the user software the Core may pull down the Sin line (Acknowledge) and slow down the SCL, as long as it is needed to carry out data from the shift register.

### I<sup>2</sup>C-bus Master-Slave, Receiver-Transmitter

When pins Sin and Sout are externally connected together it is possible to use the SPI as a receiver as well as a transmitter. Through software routine (by using bit-set and bit-reset on I/O line) a clock can be generated allowing I<sup>2</sup>C-bus to work in master mode.

When implementing an I<sup>2</sup>C-bus protocol, the start condition can be detected by setting the processor into a wait for start condition by enabling the interrupt of the I/O port used for the Sin line. This frees the processor from polling the Sin and SCL lines. After the transmission/reception the processor has to poll for the STOP condition.

In slave mode the user software can slow down the SCL clock frequency by simply putting the SCL I/O line in output open-drain mode and writing a zero into the corresponding data register bit.

As it is possible to directly read the Sin pin directly through the port register, the software can detect a difference between internal data and external data (master mode). Similar condition can be applied to the clock.

### Three (Four) Wire Serial Bus

It is possible to use a single general purpose I/O pin (with the corresponding interrupt enabled) as a chip enable pin. SCL acts as active or passive clock pin, Sin as data in and Sout as data out (four wire bus). Sin and Sout can be connected together externally to implement three wire bus.

#### Note:

When the SPI is not used, the three I/O lines (Sin, SCL, Sout) can be used as normal I/O, with the following limitation: bit Sout cannot be used in open drain mode as this enables the shift register output to the port.

It is recommended, in order to avoid spurious interrupts from the SPI to disable the SPI interrupt (the default state after reset) i.e. no write must be made to the 8-bit shift register. An explicit interrupt disable may be made in software by a dummy write to the SPI interrupt disable register.

### SPI Data/Shift Register

Address: DDh - Read/Write (SDSR)

7							0
D7	D6	D5	D4	D3	D2	D1	D0

A write into this register enables SPI Interrupt after 8 clock pulses.

### SPI Interrupt Disable Register

Address: C2h - Read/Write (SIDR)

7							0
D7	D6	D5	D4	D3	D2	D1	D0

A dummy write to this register disables SPI Interrupt.

### 4.5 LCD CONTROLLER-DRIVER

On-chip LCD driver includes all features required for LCD driving, including multiplexing of the common plates. Multiplexing allows to increase display capability without increasing the number of segment outputs. In that case, the display capability is equal to the product of the number of common plates with the number of segment outputs.

A dedicated LCD RAM is used to store the pattern to be displayed while control logic generates accordingly all the waveforms sent onto the segment or common outputs. Segments voltage supply is MCU supply independant, and included driving stages allow direct connection to the LCD panel.

The multiplexing ratio (Number of common plates) and the base LCD frame frequency is software configurable to achieve the best trade-off contrast/display capability for each display panel.

The 32Khz clock used for the LCD controller is derived from the MCU's internal clock and therefore does not require a dedicated oscillator. The division factor is set by the three bits HF0..HF2 of the LCD Mode Control Register LCDCR as summarized in Table 18 for recommended oscillator quartz values. In case of oscillator failure, all seg-

ment and common lines are switched to ground to avoid any DC biasing of the LCD elements.

**Table 18. Oscillator Selection Bits**

MCU Oscillator $f_{osc}$	HF2	HF1	HF0	Division Factor
	0	0	0	Clock disabled: Display off
	0	0	1	Auxiliary 32KHz oscillator
	0	1	0	Reserved
1.048MHz	0	1	1	32
2.097MHz	1	0	0	64
4.194MHz	1	0	1	128
8.388MHz	1	1	0	256
	1	1	1	Reserved

**Notes:**

1. The usage  $f_{osc}$  values different from those defined in this table cause the LCD to operate at a reference frequency different from 32.768KHz, according to division factor of Table 18.
2. It is not recommended to select an internal frequency lower than 32KHz as the clock supervisor circuit may switch off the LCD peripheral if lower frequency is detected.

**Figure 24. LCD Block Diagram**

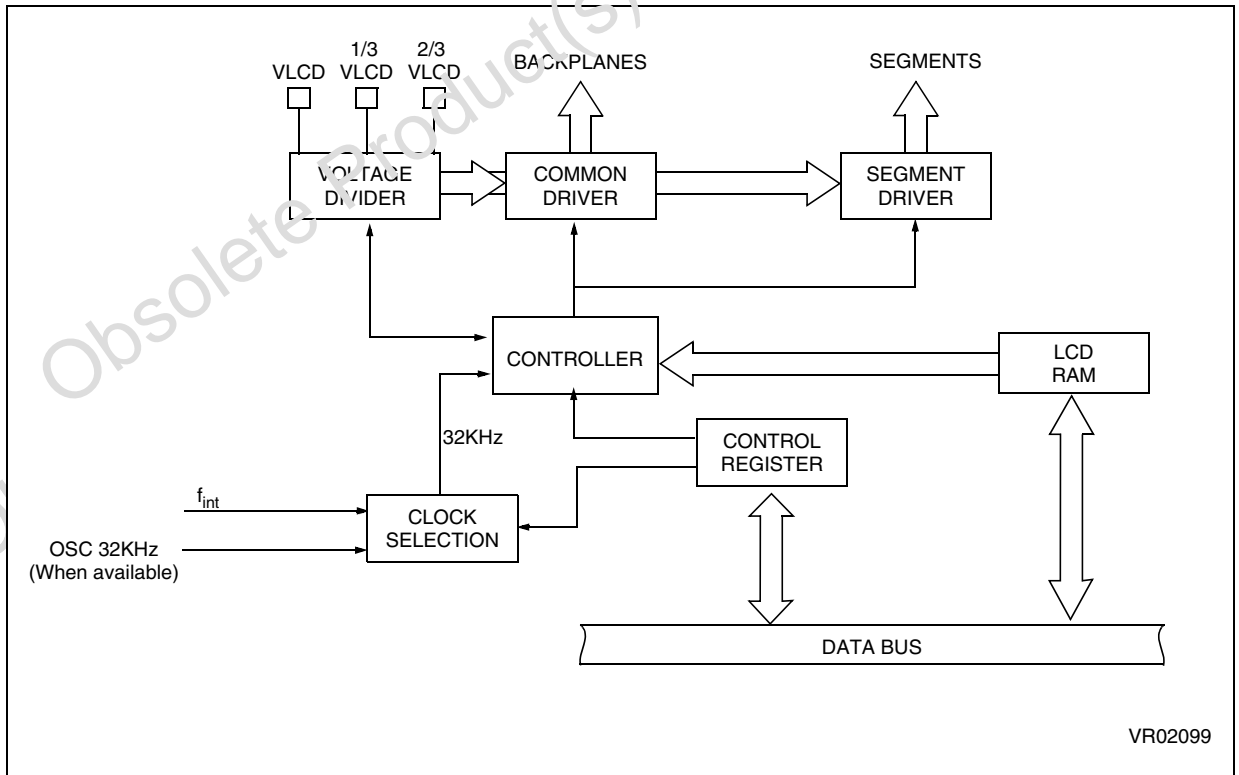

VR02099

## LCD CONTROLLER-DRIVER (Continued)

### 4.5.1 Multiplexing ratio and frame frequency setting

Up to 4 common plates COM1..COM4 can be used for multiplexing ratio ranging from 1/1 to 1/4. The selection is made by the bits DS0 and DS1 of the LCDCR as shown in the [Table 19](#).

**Table 19. Multiplexing ratio**

DS1	DS0	Display Mode	Active backplanes
0	0	1/4 mux.ratio	COM1, 2, 3, 4
0	1	1/1 mux.ratio	COM1
1	0	1/2 mux.ratio	COM1, 2
1	1	1/3 mux.ratio	COM1, 2, 3

If the 1/1 multiplexing ratio is chosen, LCD segments are refreshed with a frame frequency  $f_{LCD}$  derived from 32Khz clock with a division ratio defined by the bits LF0..LF2 of the LCDCR.

When a higher multiplexing ratio is set, refreshment frequency is decreased accordingly ([Table 20](#)).

**Table 20. LCD Frame Frequency Selection**

LF2	LF1	LF0	Base $f_{LCD}$ (Hz)	Frame Frequency $f_F$ (Hz)			
				1/1 mux. ratio	1/2 mux. ratio	1/3 mux. ratio	1/4 mux. ratio
0	0	0	64	64	32	21	16
0	0	1	85	85	43	28	21
0	1	0	128	128	64	43	32
0	1	1	171	171	85	57	43
1	0	0	256	256	128	85	64
1	0	1	341	341	171	114	85
1	1	0	512	512	256	171	128
1	1	1	Reserved				

### 4.5.2 Segment and common plates driving

LCD panels physical structure requires precise timings and stepped voltage values on common and segment outputs. Timings are managed by the LCD controller, while voltages are derived from the VLCD value through internal resistive division. This internal divider is disabled when the LCD driver is OFF in order to avoid consumption on VLCD pin.

The 1/3 VLCD and 2/3 VLCD values used in 1/1, 1/3 and 1/4 multiplexing ratio modes are internally generated and issued on external pins, while 1/2 VLCD value used in 1/2 mode is obtained by exter-

nal connection of the 1/3VLCD and 2/3VLCD pins ([Figure 25](#)).

**Figure 25. Bias Config for 1/2 Duty**

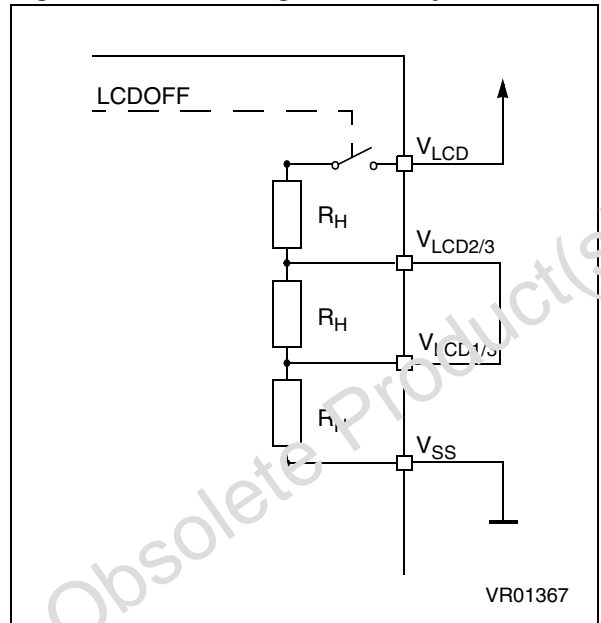

**Figure 26. Typical Current consumption on VLCD Pin (25°C, no load,  $f_{LCD}=512\text{Hz}$ , mux=1/3-1/4)**

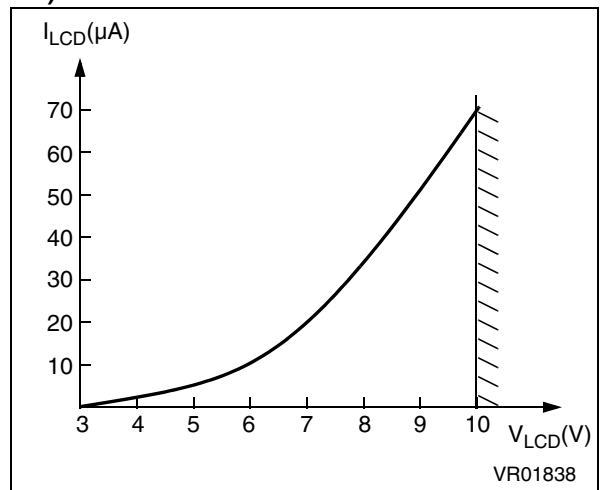

**Note:** For display voltages  $V_{LCD} < 4.5\text{V}$  the resistivity of the divider may be too high for some applications (especially using 1/3 or 1/4 duty display mode). In that case an external resistive divider must be used to achieve the desired resistivity.

LCD CONTROLLER-DRIVER (Continued)

Figure 27. Typical Network to connect to  $V_{LCD}$  pins if  $V_{LCD} \leq 4.5V$

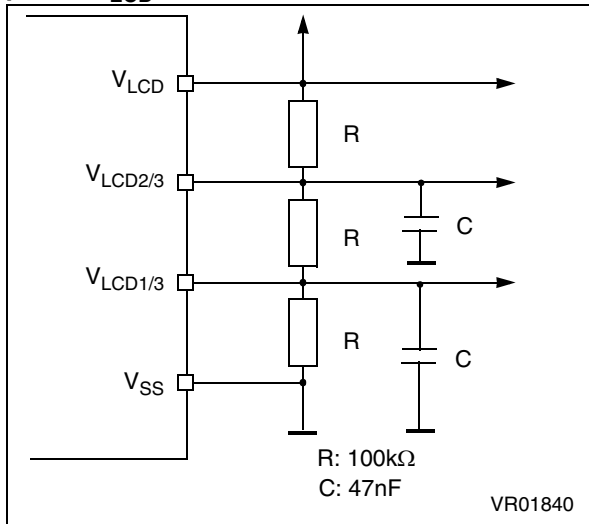

Typical External resistances values are in the range of 100 kΩ to 150 kΩ. External capacitances in the range of 10 to 47 nF can be added to  $V_{LCD}$  2/3 and  $V_{LCD}$  1/3 pins and to  $V_{LCD}$  if the  $V_{LCD}$  connection is highly impedant.

4.5.3 LCD RAM

LCD RAM is organised as a LCD panel with a matrix architecture. Each bit of its content is logically mapped to a physical element of the display panel addressed by a couple (Segment;Common). If a bit is set, the relevant element of the LCD matrix is turned-on. On the contrary, an element remains turned-off as long the associated bit within the LCD RAM is kept cleared.

After a reset, the LCD RAM is not initialised and contain arbitrary information.

If the chosen multiplexing ratio does not use some common plates, corresponding RAM addresses are free for general purpose data storage.

Figure 28. Addressing Map of the LCD RAM

RAM Address	MSB								LSB
E0	S8	S7	S6	S5	S4	NA	NA	NA	COM1
E1	S16	S15	S14	S13	S12	S11	S10	S9	
E2	S24	S23	S22	S21	S20	S19	S18	S17	
E3	S32	S31	S30	S29	S28	S27	S26	S25	
E4	S40	S39	S38	S37	S36	S35	S34	S33	
E5	S48	S47	S46	S45	S44	S43	S42	S41	COM2
E6	S8	S7	S6	S5	S4	NA	NA	NA	
E7	S16	S15	S14	S13	S12	S11	S10	S9	
E8	S24	S23	S22	S21	S20	S19	S18	S17	
E9	S32	S31	S30	S29	S28	S27	S26	S25	
EA	S40	S39	S38	S37	S36	S35	S34	S33	COM3
EB	S48	S47	S46	S45	S44	S43	S42	S41	
EC	S8	S7	S6	S5	S4	NA	NA	NA	
ED	S16	S15	S14	S13	S12	S11	S10	S9	
EE	S24	S23	S22	S21	S20	S19	S18	S17	
EF	S32	S31	S30	S29	S28	S27	S26	S25	COM4
F0	S40	S39	S38	S37	S36	S35	S34	S33	
F1	S48	S47	S46	S45	S44	S43	S42	S41	
F2	S8	S7	S6	S5	S4	NA	NA	NA	
F3	S16	S15	S14	S13	S12	S11	S10	S9	
F4	S24	S23	S22	S21	S20	S19	S18	S17	COM4
F5	S32	S31	S30	S29	S28	S27	S26	S25	
F6	S40	S39	S38	S37	S36	S35	S34	S33	
F7	S48	S47	S46	S45	S44	S43	S42	S41	

**LCD CONTROLLER-DRIVER (Continued)****4.5.4 Stand by or STOP operation mode**

No clock from the main oscillator is available in STOP mode for the LCD controller, and the controller is switched off when the STOP instruction is executed. All segment and common lines are then switched to ground to avoid any DC biasing of the LCD elements.

**4.5.5 LCD Mode Control Register (LCDCR)**

Address: DCh - Read/Write

7							0
DS1	DS0	HF2	HF1	HF0	LF2	LF1	LF0

Bits 7-6 = **DS0, DS1**. *Multiplexing ratio select bits*. These bits select the number of common back-planes used by the LCD control.

Bits 5-3 = **HF0, HF1, HF2**. *Oscillator select bits*. These bits allow the LCD controller to be supplied with the correct frequency when different high main oscillator frequencies are selected as system clock. [Table 18](#) shows the set-up for different clock crystals.

Bits 2-0 = **LF0, LF1, LF2**. *Base frame frequency select bits*. These bits control the LCD base operational frequency of the LCD common lines.

## 5 SOFTWARE

### 5.1 ST6 ARCHITECTURE

The ST6 software has been designed to fully use the hardware in the most efficient way possible while keeping byte usage to a minimum; in short, to provide byte efficient programming capability. The ST6 core has the ability to set or clear any register or RAM location bit of the Data space with a single instruction. Furthermore, the program may branch to a selected address depending on the status of any bit of the Data space. The carry bit is stored with the value of the bit when the SET or RES instruction is processed.

### 5.2 ADDRESSING MODES

The ST6 core offers nine addressing modes, which are described in the following paragraphs. Three different address spaces are available: Program space, Data space, and Stack space. Program space contains the instructions which are to be executed, plus the data for immediate mode instructions. Data space contains the Accumulator, the X,Y,V and W registers, peripheral and Input/Output registers, the RAM locations and Data ROM locations (for storage of tables and constants). Stack space contains six 12-bit RAM cells used to stack the return addresses for subroutines and interrupts.

**Immediate.** In the immediate addressing mode, the operand of the instruction follows the opcode location. As the operand is a ROM byte, the immediate addressing mode is used to access constants which do not change during program execution (e.g., a constant used to initialize a loop counter).

**Direct.** In the direct addressing mode, the address of the byte which is processed by the instruction is stored in the location which follows the opcode. Direct addressing allows the user to directly address the 256 bytes in Data Space memory with a single two-byte instruction.

**Short Direct.** The core can address the four RAM registers X,Y,V,W (locations 80h, 81h, 82h, 83h) in the short-direct addressing mode. In this case, the instruction is only one byte and the selection of the location to be processed is contained in the opcode. Short direct addressing is a subset of the direct addressing mode. (Note that 80h and 81h are also indirect registers).

**Extended.** In the extended addressing mode, the 12-bit address needed to define the instruction is obtained by concatenating the four less significant

bits of the opcode with the byte following the opcode. The instructions (JP, CALL) which use the extended addressing mode are able to branch to any address of the 4K bytes Program space.

An extended addressing mode instruction is two-byte long.

**Program Counter Relative.** The relative addressing mode is only used in conditional branch instructions. The instruction is used to perform a test and, if the condition is true, a branch with a span of -15 to +16 locations around the address of the relative instruction. If the condition is not true, the instruction which follows the relative instruction is executed. The relative addressing mode instruction is one-byte long. The opcode is obtained in adding the three most significant bits which characterize the kind of the test, one bit which determines whether the branch is a forward (when it is 0) or backward (when it is 1) branch and the four less significant bits which give the span of the branch (0h to Fh) which must be added or subtracted to the address of the relative instruction to obtain the address of the branch.

**Bit Direct.** In the bit direct addressing mode, the bit to be set or cleared is part of the opcode, and the byte following the opcode points to the address of the byte in which the specified bit must be set or cleared. Thus, any bit in the 256 locations of Data space memory can be set or cleared.

**Bit Test & Branch.** The bit test and branch addressing mode is a combination of direct addressing and relative addressing. The bit test and branch instruction is three-byte long. The bit identification and the tested condition are included in the opcode byte. The address of the byte to be tested follows immediately the opcode in the Program space. The third byte is the jump displacement, which is in the range of -127 to +128. This displacement can be determined using a label, which is converted by the assembler.

**Indirect.** In the indirect addressing mode, the byte processed by the register-indirect instruction is at the address pointed by the content of one of the indirect registers, X or Y (80h,81h). The indirect register is selected by the bit 4 of the opcode. A register indirect instruction is one byte long.

**Inherent.** In the inherent addressing mode, all the information necessary to execute the instruction is contained in the opcode. These instructions are one byte long.

### 5.3 INSTRUCTION SET

The ST6 core offers a set of 40 basic instructions which, when combined with nine addressing modes, yield 244 usable opcodes. They can be divided into six different types: load/store, arithmetic/logic, conditional branch, control instructions, jump/call, and bit manipulation. The following paragraphs describe the different types.

All the instructions belonging to a given type are presented in individual tables.

**Load & Store.** These instructions use one, two or three bytes in relation with the addressing mode. One operand is the Accumulator for LOAD and the other operand is obtained from data memory using one of the addressing modes.

For Load Immediate one operand can be any of the 256 data space bytes while the other is always immediate data.

**Table 21. Load & Store Instructions**

Instruction	Addressing Mode	Bytes	Cycles	Flags	
				Z	C
LD A, X	Short Direct	1	4	Δ	*
LD A, Y	Short Direct	1	4	Δ	*
LD A, V	Short Direct	1	4	Δ	*
LD A, W	Short Direct	1	4	Δ	*
LD X, A	Short Direct	1	4	Δ	*
LD Y, A	Short Direct	1	4	Δ	*
LD V, A	Short Direct	1	4	Δ	*
LD W, A	Short Direct	1	4	Δ	*
LD A, rr	Direct	2	4	Δ	*
LD rr, A	Direct	2	4	Δ	*
LD A, (X)	Indirect	1	4	Δ	*
LD A, (Y)	Indirect	1	4	Δ	*
LD (X), A	Indirect	1	4	Δ	*
LD (Y), A	Indirect	1	4	Δ	*
LDI A, #N	Immediate	2	4	Δ	*
LDI rr, #N	Immediate	3	4	*	*

**Notes:**

X, Y. Indirect Register Pointers V & W Short Direct Registers

#. Immediate data (stored in ROM memory)

rr. Data space register

Δ. Affected

\*. Not Affected

## INSTRUCTION SET (Cont'd)

**Arithmetic and Logic.** These instructions are used to perform the arithmetic calculations and logic operations. In AND, ADD, CP, SUB instructions one operand is always the accumulator while the other can be either a data space memory con-

tent or an immediate value in relation with the addressing mode. In CLR, DEC, INC instructions the operand can be any of the 256 data space addresses. In COM, RLC, SLA the operand is always the accumulator.

Table 22. Arithmetic &amp; Logic Instructions

Instruction	Addressing Mode	Bytes	Cycles	Flags	
				Z	C
ADD A, (X)	Indirect	1	4	Δ	Δ
ADD A, (Y)	Indirect	1	4	Δ	Δ
ADD A, rr	Direct	2	4	Δ	Δ
ADDI A, #N	Immediate	2	4	Δ	Δ
AND A, (X)	Indirect	1	4	Δ	Δ
AND A, (Y)	Indirect	1	4	Δ	Δ
AND A, rr	Direct	2	4	Δ	Δ
ANDI A, #N	Immediate	2	4	Δ	Δ
CLR A	Short Direct	2	4	Δ	Δ
CLR r	Direct	3	4	*	*
COM A	Inherent	1	4	Δ	Δ
CP A, (X)	Indirect	1	4	Δ	Δ
CP A, (Y)	Indirect	1	4	Δ	Δ
CP A, rr	Direct	2	4	Δ	Δ
CPI A, #N	Immediate	2	4	Δ	Δ
DEC X	Short Direct	1	4	Δ	*
DEC Y	Short Direct	1	4	Δ	*
DEC V	Short Direct	1	4	Δ	*
DEC W	Short Direct	1	4	Δ	*
DEC A	Direct	2	4	Δ	*
DEC rr	Direct	2	4	Δ	*
DEC (X)	Indirect	1	4	Δ	*
DEC (Y)	Indirect	1	4	Δ	*
INC X	Short Direct	1	4	Δ	*
INC Y	Short Direct	1	4	Δ	*
INC V	Short Direct	1	4	Δ	*
INC W	Short Direct	1	4	Δ	*
INC A	Direct	2	4	Δ	*
INC rr	Direct	2	4	Δ	*
INC (X)	Indirect	1	4	Δ	*
INC (Y)	Indirect	1	4	Δ	*
RLC A	Inherent	1	4	Δ	Δ
SLA A	Inherent	2	4	Δ	Δ
SUB A, (X)	Indirect	1	4	Δ	Δ
SUB A, (Y)	Indirect	1	4	Δ	Δ
SUB A, rr	Direct	2	4	Δ	Δ
SUBI A, #N	Immediate	2	4	Δ	Δ

**Notes:**

X,Y. Indirect Register Pointers, V & W Short Direct Registers  
 Δ. Affected  
 # . Immediate data (stored in ROM memory)  
 \* . Not Affected  
 rr. Data space register

## INSTRUCTION SET (Cont'd)

**Conditional Branch.** The branch instructions achieve a branch in the program when the selected condition is met.

**Bit Manipulation Instructions.** These instructions can handle any bit in data space memory. One group either sets or clears. The other group (see Conditional Branch) performs the bit test branch operations.

**Control Instructions.** The control instructions control the MCU operations during program execution.

**Jump and Call.** These two instructions are used to perform long (12-bit) jumps or subroutines call inside the whole program space.

Table 23. Conditional Branch Instructions

Instruction	Branch If	Bytes	Cycles	Flags	
				Z	C
JRC e	C = 1	1	2	*	*
JRNC e	C = 0	1	2	*	*
JRZ e	Z = 1	1	2	*	*
JRNZ e	Z = 0	1	2	*	*
JRR b, rr, ee	Bit = 0	3	5	*	Δ
JRS b, rr, ee	Bit = 1	3	5	*	Δ

**Notes:**

b. 3-bit address

e. 5 bit signed displacement in the range -15 to +16&lt;F128M&gt;

ee. 8 bit signed displacement in the range -126 to +129

rr. Data space register

Δ. Affected. The tested bit is shifted into carry.

\*. Not Affected

Table 24. Bit Manipulation Instructions

Instruction	Addressing Mode	Bytes	Cycles	Flags	
				Z	C
SET b,rr	Bit Direct	2	4	*	*
RES b,rr	Bit Direct	2	4	*	*

**Notes:**

b. 3-bit address;

rr. Data space register;

\*. Not&lt;M&gt; Affected

Table 25. Control Instructions

Instruction	Addressing Mode	Bytes	Cycles	Flags	
				Z	C
NOP	Inherent	1	2	*	*
RET	Inherent	1	2	*	*
RETI	Inherent	1	2	Δ	Δ
STJP (1)	Inherent	1	2	*	*
WAIT	Inherent	1	2	*	*

**Notes:**

1. This instruction is deactivated&lt;N&gt;and a WAIT is automatically executed instead of a STOP if the watchdog function is selected.

Δ. Affected

\*. Not Affected

Table 26. Jump &amp; Call Instructions

Instruction	Addressing Mode	Bytes	Cycles	Flags	
				Z	C
CALL abc	Extended	2	4	*	*
JP abc	Extended	2	4	*	*

**Notes:**

abc. 12-bit address;

\*. Not Affected

**Opcode Map Summary.** The following table contains an opcode map for the instructions used by the ST6

LOW HI	0 0000	1 0001	2 0010	3 0011	4 0100	5 0101	6 0110	7 0111	LOW HI
0 0000	2 JRNZ e 1 pcr	4 CALL abc 2 ext	2 JRNC e 1 pcr	5 JRR b0,rr,ee 3 bt	2 JRZ e 1 pcr	#	2 JRC e 1 prc	4 LD a,(x) 1 ind	0 0000
1 0001	2 JRNZ e 1 pcr	4 CALL abc 2 ext	2 JRNC e 1 pcr	5 JRS b0,rr,ee 3 bt	2 JRZ e 1 pcr	4 INC x 1 sd	2 JRC e 1 prc	4 LDI a,nn 2 imm	1 0001
2 0010	2 JRNZ e 1 pcr	4 CALL abc 2 ext	2 JRNC e 1 pcr	5 JRR b4,rr,ee 3 bt	2 JRZ e 1 pcr	#	2 JRC e 1 prc	4 CP a,(x) 1 ind	2 0010
3 0011	2 JRNZ e 1 pcr	4 CALL abc 2 ext	2 JRNC e 1 pcr	5 JRS b4,rr,ee 3 bt	2 JRZ e 1 pcr	4 LD a,x 1 sd	2 JRC e 1 prc	4 CPI a,nn 2 imm	3 0011
4 0100	2 JRNZ e 1 pcr	4 CALL abc 2 ext	2 JRNC e 1 pcr	5 JRR b2,rr,ee 3 bt	2 JRZ e 1 pcr	#	2 JRC e 1 prc	4 ADD a,(x) 1 inc	4 0100
5 0101	2 JRNZ e 1 pcr	4 CALL abc 2 ext	2 JRNC e 1 pcr	5 JRS b2,rr,ee 3 bt	2 JRZ e 1 pcr	4 INC y 1 sd	2 JRC e 1 prc	4 ADUI a,nn 2 imm	5 0101
6 0110	2 JRNZ e 1 pcr	4 CALL abc 2 ext	2 JRNC e 1 pcr	5 JRR b6,rr,ee 3 bt	2 JRZ e 1 pcr	#	2 JRC e 1 prc	4 INC (x) 1 ind	6 0110
7 0111	2 JRNZ e 1 pcr	4 CALL abc 2 ext	2 JRNC e 1 pcr	5 JRS b6,rr,ee 3 bt	2 JRZ e 1 pcr	4 LD a, 1 sd	2 JRC e 1 prc	#	7 0111
8 1000	2 JRNZ e 1 pcr	4 CALL abc 2 ext	2 JRNC e 1 pcr	5 JRR b1,rr,ee 3 bt	2 JRZ e 1 pcr	#	2 JRC e 1 prc	4 LD (x),a 1 ind	8 1000
9 1001	2 RNZ e 1 pcr	4 CALL abc 2 ext	2 JRNC e 1 pcr	5 JRR b1,rr,ee 3 bt	2 JRZ e 1 pcr	4 INC v 1 sd	2 JRC e 1 prc	#	9 1001
A 1010	2 JRNZ e 1 pcr	4 CALL abc 2 ext	2 JRNC e 1 pcr	5 JRR b5,rr,ee 3 bt	2 JRZ e 1 pcr	#	2 JRC e 1 prc	4 AND a,(x) 1 ind	A 1010
B 1011	2 JRNZ e 1 pcr	4 CALL abc 2 ext	2 JRNC e 1 pcr	5 JRS b5,rr,ee 3 bt	2 JRZ e 1 pcr	4 LD a,v 1 sd	2 JRC e 1 prc	4 ANDI a,nn 2 imm	B 1011
C 1100	2 JRNZ e 1 pcr	4 CALL abc 2 ext	2 JRNC e 1 pcr	5 JRR b3,rr,ee 3 bt	2 JRZ e 1 pcr	#	2 JRC e 1 prc	4 SUB a,(x) 1 ind	C 1100
D 1101	2 JRNZ e 1 pcr	4 CALL abc 2 ext	2 JRNC e 1 pcr	5 JRS b3,rr,ee 3 bt	2 JRZ e 1 pcr	4 INC w 1 sd	2 JRC e 1 prc	4 SUBI a,nn 2 imm	D 1101
E 1110	2 JRNZ e 1 pcr	4 CALL abc 2 ext	2 JRNC e 1 pcr	5 JRR b7,rr,ee 3 bt	2 JRZ e 1 pcr	#	2 JRC e 1 prc	4 DEC (x) 1 ind	E 1110
F 1111	2 JRNZ e 1 pcr	4 CALL abc 2 ext	2 JRNC e 1 pcr	5 JRS b7,rr,ee 3 bt	2 JRZ e 1 pcr	4 LD a,w 1 sd	2 JRC e 1 prc	#	F 1111

**Abbreviations for Addressing Modes: Legend:**

- dir Direct
- sd Short Direct
- imm Immediate
- inh Inherent
- ext Extended
- b.d Bit Direct
- bt Bit Test
- pcr Program Counter Relative
- ind Indirect
- # Indicates Illegal Instructions
- e 5 Bit Displacement
- b 3 Bit Address
- rr 1byte dataspace address
- nn 1 byte immediate data
- abc 12 bit address
- ee 8 bit Displacement

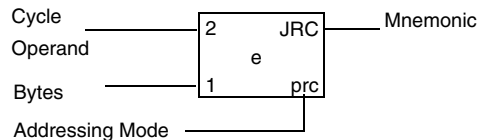

Opcode Map Summary (Continued)

LOW HI	8 1000	9 1001	A 1010	B 1011	C 1100	D 1101	E 1110	F 1111	LOW HI
0 0000	2 JRNZ e 1 pcr	4 JP abc 2 ext	2 JRNC e 1 pcr	4 RES b0,rr 2 b.d	2 JRZ e 1 pcr	4 LDI rr,nn 3 imm	2 JRC e 1 prc	4 LD a,(y) 1 ind	0 0000
1 0001	2 JRNZ e 1 pcr	4 JP abc 2 ext	2 JRNC e 1 pcr	4 SET b0,rr 2 b.d	2 JRZ e 1 pcr	4 DEC x 1 sd	2 JRC e 1 prc	4 LD a,rr 2 dir	1 0001
2 0010	2 JRNZ e 1 pcr	4 JP abc 2 ext	2 JRNC e 1 pcr	4 RES b4,rr 2 b.d	2 JRZ e 1 pcr	4 COM a 1	2 JRC e 1 prc	4 CP a,(y) 1 ind	2 0010
3 0011	2 JRNZ e 1 pcr	4 JP abc 2 ext	2 JRNC e 1 pcr	4 SET b4,rr 2 b.d	2 JRZ e 1 pcr	4 LD x,a 1 sd	2 JRC e 1 prc	4 CP a,rr 2 dir	3 0011
4 0100	2 JRNZ e 1 pcr	4 JP abc 2 ext	2 JRNC e 1 pcr	4 RES b2,rr 2 b.d	2 JRZ e 1 pcr	2 RETI 1 inh	2 JRC e 1 prc	4 ADD a,(y) 1 ind	4 0100
5 0101	2 JRNZ e 1 pcr	4 JP abc 2 ext	2 JRNC e 1 pcr	4 SET b2,rr 2 b.d	2 JRZ e 1 pcr	4 DEC y 1 sd	2 JRC e 1 prc	4 LD a,rr 2 dir	5 0101
6 0110	2 JRNZ e 1 pcr	4 JP abc 2 ext	2 JRNC e 1 pcr	4 RES b6,rr 2 b.d	2 JRZ e 1 pcr	2 STOP 1 inh	2 JRC e 1 prc	4 INC (y) 1 ind	6 0110
7 0111	2 JRNZ e 1 pcr	4 JP abc 2 ext	2 JRNC e 1 pcr	4 SET b6,rr 2 b.d	2 JRZ e 1 pcr	4 LD y,e 1 sd	2 JRC e 1 prc	4 INC rr 2 dir	7 0111
8 1000	2 JRNZ e 1 pcr	4 JP abc 2 ext	2 JRNC e 1 pcr	4 RES b1,rr 2 b.d	2 JRZ e 1 pcr	#	2 JRC e 1 prc	4 LD (y),a 1 ind	8 1000
9 1001	2 RNZ e 1 pcr	4 JP abc 2 ext	2 JRNC e 1 pcr	4 SET b1,rr 2 b.d	2 JRZ e 1 pcr	4 DEC v 1 sd	2 JRC e 1 prc	4 LD rr,a 2 dir	9 1001
A 1010	2 JRNZ e 1 pcr	4 JP abc 2 ext	2 JRNC e 1 pcr	4 RES b5,rr 2 b.d	2 JRZ e 1 pcr	4 RCL a 1 inh	2 JRC e 1 prc	4 AND a,(y) 1 ind	A 1010
B 1011	2 JRNZ e 1 pcr	4 JP abc 2 ext	2 JRNC e 1 pcr	4 SET b5,rr 2 b.d	2 JRZ e 1 pcr	4 LD v,a 1 sd	2 JRC e 1 prc	4 AND a,rr 2 dir	B 1011
C 1100	2 JRNZ e 1 pcr	4 JP abc 2 ext	2 JRNC e 1 pcr	4 RES b3,rr 2 b.d	2 JRZ e 1 pcr	2 RET 1 inh	2 JRC e 1 prc	4 SUB a,(y) 1 ind	C 1100
D 1101	2 JRNZ e 1 pcr	4 JP abc 2 ext	2 JRNC e 1 pcr	4 SET b3,rr 2 b.d	2 JRZ e 1 pcr	4 DEC w 1 sd	2 JRC e 1 prc	4 SUB a,rr 2 dir	D 1101
E 1110	2 JRNZ e 1 pcr	4 JP abc 2 ext	2 JRNC e 1 pcr	4 RES b7,rr 2 b.d	2 JRZ e 1 pcr	2 WAIT 1 inh	2 JRC e 1 prc	4 DEC (y) 1 ind	E 1110
F 1111	2 JRNZ e 1 pcr	4 JP abc 2 ext	2 JRNC e 1 pcr	4 SET b7,rr 2 b.d	2 JRZ e 1 pcr	4 LD w,a 1 sd	2 JRC e 1 prc	4 DEC rr 2 dir	F 1111

Abbreviations for Addressing Modes: Legend:

- dir Direct
- sd Short Direct
- imm Immediate
- inh Inherent
- ext Extended
- b.d Bit Direct
- bt Bit Test
- pcr Program Counter Relative
- ind Indirect
- # Indicates Illegal Instructions
- e 5 Bit Displacement
- b 3 Bit Address
- rr 1byte dataspace address
- nn 1 byte immediate data
- abc 12 bit address
- ee 8 bit Displacement

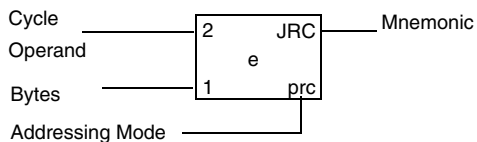

## 6 ELECTRICAL CHARACTERISTICS

### 6.1 ABSOLUTE MAXIMUM RATINGS

This product contains devices to protect the inputs against damage due to high static voltages, however it is advisable to take normal precaution to avoid application of any voltage higher than the specified maximum rated voltages.

For proper operation it is recommended that  $V_I$  and  $V_O$  be higher than  $V_{SS}$  and lower than  $V_{DD}$ . Reliability is enhanced if unused inputs are connected to an appropriate logic voltage level ( $V_{DD}$  or  $V_{SS}$ ).

**Power Considerations.** The average chip-junction temperature,  $T_j$ , in Celsius can be obtained from:

$$T_j = T_A + P_D \times R_{thJA}$$

Where:  $T_A$  = Ambient Temperature.

$R_{thJA}$  = Package thermal resistance (junction-to ambient).

$P_D$  =  $P_{int} + P_{port}$ .

$P_{int}$  =  $I_{DD} \times V_{DD}$  (chip internal power).

$P_{port}$  = Port power dissipation (determined by the user).

Symbol	Parameter	Value	Unit
$V_{DD}$	Supply Voltage	-0.3 to 7.0	V
$V_I$	Input Voltage	$V_{SS} - 0.3$ to $V_{DD} + 0.3^{(1)}$	V
$V_O$	Output Voltage	$V_{SS} - 0.3$ to $V_{DD} + 0.3^{(1)}$	V
$I_O$	Current Drain per Pin Excluding $V_{DD}$ , $V_{SS}$	$\pm 10$	mA
$I_{V_{DD}}$	Total Current into $V_{DD}$ (source)	50	mA
$I_{V_{SS}}$	Total Current out of $V_{SS}$ (sink)	50	mA
$T_j$	Junction Temperature	150	$^{\circ}\text{C}$
$T_{STG}$	Storage Temperature	-60 to 150	$^{\circ}\text{C}$

#### Notes:

- Stresses above those listed as "absolute maximum ratings" may cause permanent damage to the device. This is a stress rating only and functional operation of the device at these conditions is not implied. Exposure to maximum rating conditions for extended periods may affect device reliability.
- (1) Within these limits, clamping diodes are guaranteed to be not conductive. Voltages outside these limits are authorised as long as injection current is kept within the specification.

## 6.2 RECOMMENDED OPERATING CONDITIONS

Symbol	Parameter	Test Conditions	Value			Unit
			Min.	Typ.	Max.	
$T_A$	Operating Temperature	6 Suffix Version 1 Suffix Version	-40 0		85 70	°C
$V_{DD}$	Operating Supply Voltage	$f_{OSC} = 4\text{MHz}$ $f_{osc} = 8\text{MHz}$	3.0 4.5		6.0 6.0	V
$f_{OSC}$	Oscillator Frequency <sup>2)</sup>	$V_{DD} = 3\text{V}$ $V_{DD} = 4.5\text{V}$	0 0		4.0 8.0	MHz
$I_{INJ+}$	Pin Injection Current (positive)	$V_{DD} = 4.5$ to $5.5\text{V}$			+5	mA
$I_{INJ-}$	Pin Injection Current (negative)	$V_{DD} = 4.5$ to $5.5\text{V}$			-5	mA

## Notes:

- Care must be taken in case of negative current injection, where adapted impedance must be respected on analog sources to not affect the A/D conversion. For a -1mA injection, a maximum 10 K $\Omega$  is recommended.
- An oscillator frequency above 1MHz is recommended for reliable A/D results.

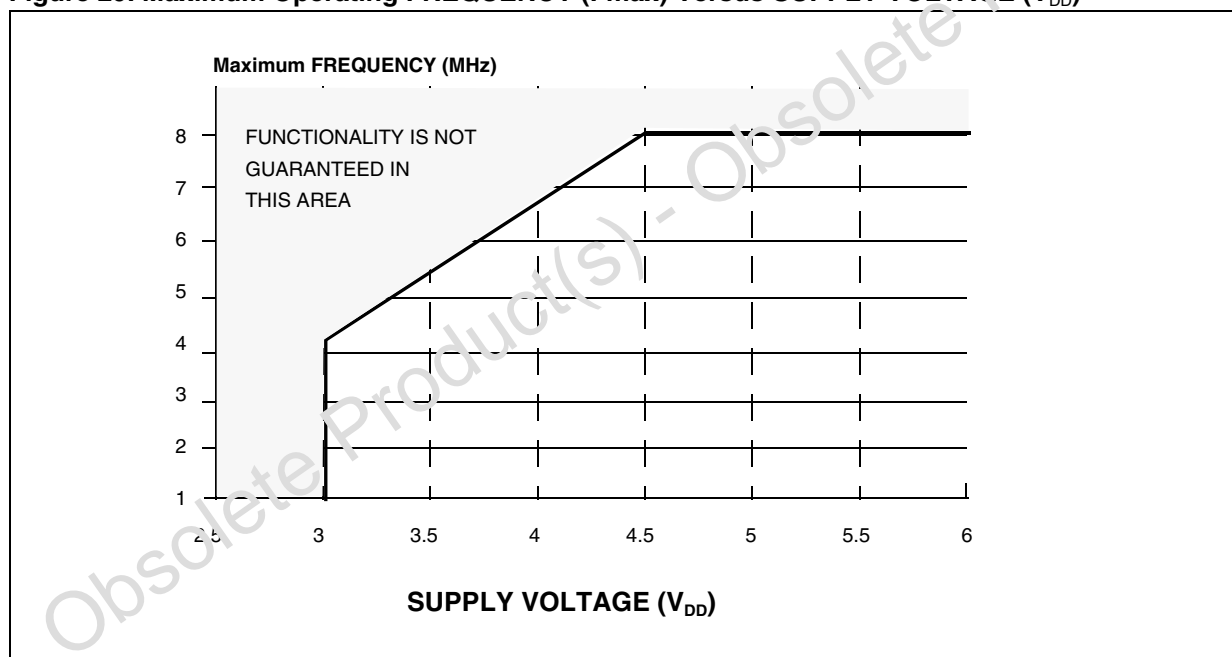
Figure 29. Maximum Operating FREQUENCY (Fmax) Versus SUPPLY VOLTAGE ( $V_{DD}$ )

The shaded area is outside the recommended operating range; device functionality is not guaranteed under these conditions.

## 6.3 DC ELECTRICAL CHARACTERISTICS

(T<sub>A</sub> = -40 to +85°C unless otherwise specified)

Symbol	Parameter	Test Conditions	Value			Unit
			Min.	Typ.	Max.	
V <sub>IL</sub>	Input Low Level Voltage All Input pins				V <sub>DD</sub> × 0.3	V
V <sub>IH</sub>	Input High Level Voltage All Input pins		V <sub>DD</sub> × 0.7			V
V <sub>Hys</sub>	Hysteresis Voltage <sup>(1)</sup> All Input pins	V <sub>DD</sub> = 5V V <sub>DD</sub> = 3V	0.2 0.2			V
V <sub>OL</sub>	Low Level Output Voltage All Output pins	V <sub>DD</sub> = 5.0V; I <sub>OL</sub> = +10μA V <sub>DD</sub> = 5.0V; I <sub>OL</sub> = + 5mA			0.1 0.8	V
	Low Level Output Voltage 20 mA Sink I/O pins	V <sub>DD</sub> = 5.0V; I <sub>OL</sub> = +10μA V <sub>DD</sub> = 5.0V; I <sub>OL</sub> = +10mA V <sub>DD</sub> = 5.0V; I <sub>OL</sub> = +20mA			0.1 0.8 1.3	
V <sub>OH</sub>	High Level Output Voltage All Output pins	V <sub>DD</sub> = 5.0V; I <sub>OL</sub> = -10μA V <sub>DD</sub> = 5.0V; I <sub>OL</sub> = -5.0mA	4.9 3.5			V
R <sub>PU</sub>	Pull-up Resistance	All Input pins	40	100	200	KΩ
		RESET pin	150	350	900	
I <sub>IL</sub> I <sub>IH</sub>	Input Leakage Current All Input pins but RESET	V <sub>IN</sub> = V <sub>SS</sub> (No Pull-Up configured) V <sub>IN</sub> = V <sub>DD</sub>		0.1	1.0	μA
	Input Leakage Current RESET pin	V <sub>IN</sub> = V <sub>SS</sub> V <sub>IN</sub> = V <sub>DD</sub>	-3	-16	-30 10	
I <sub>DD</sub>	Supply Current in RESET Mode	V <sub>RESET</sub> =V <sub>SS</sub> f <sub>OSC</sub> =8MHz			7	mA
	Supply Current in RUN Mode <sup>(2)</sup>	V <sub>DD</sub> =5.0V f <sub>INT</sub> =2MHz			7	mA
	Supply Current in WAIT Mode <sup>(3)</sup>	V <sub>DD</sub> =5.0V f <sub>INT</sub> =8MHz			2	mA
	Supply Current in STOP Mode <sup>(3)</sup>	I <sub>IN</sub> =10μA V <sub>DD</sub> =5.0V			10	μA

**Notes:**

- (1) Hysteresis voltage between switching levels  
(2) All peripherals running  
(3) All peripherals in stand-by

## 6.4 AC ELECTRICAL CHARACTERISTICS

( $T_A = -40$  to  $+85^\circ\text{C}$  unless otherwise specified)

Symbol	Parameter	Test Conditions	Value			Unit
			Min.	Typ.	Max.	
$t_{\text{REC}}$	Supply Recovery Time <sup>(1)</sup>		100			ms
$T_{\text{WR}}$	Minimum Pulse Width ( $V_{\text{DD}} = 5\text{V}$ ) RESET pin NMI pin		100 100			ns
$T_{\text{WEE}}$	EEPROM Write Time	$T_A = 25^\circ\text{C}$ $T_A = 85^\circ\text{C}$		5 10	10 20	ms
Endurance	EEPROM WRITE/ERASE Cycle	$Q_A L_{\text{OT}}$ Acceptance	300,000	1 million		cycles
Retention	EEPROM Data Retention	$T_A = 55^\circ\text{C}$	10			years
$C_{\text{IN}}$	Input Capacitance	All Inputs Pins			10	pF
$C_{\text{OUT}}$	Output Capacitance	All Outputs Pins			10	pF

### Notes:

1. Period for which  $V_{\text{DD}}$  has to be connected at 0V to allow internal Reset function at next power-up.

## 6.5 A/D CONVERTER CHARACTERISTICS

( $T_A = -40$  to  $+85^\circ\text{C}$  unless otherwise specified)

Symbol	Parameter	Test Conditions	Value			Unit
			Min.	Typ.	Max.	
Res	Resolution			8		Bit
$A_{\text{TOT}}$	Total Accuracy <sup>(1) (2)</sup>	$f_{\text{OSC}} > 1.2\text{MHz}$ $f_{\text{OSC}} > 32\text{kHz}$			$\pm 2$ $\pm 4$	LSB
$t_{\text{C}}$	Conversion Time	$f_{\text{OSC}} = 1\text{MHz}$		70		$\mu\text{s}$
ZIR	Zero Input Reading	Conversion result when $V_{\text{IN}} = V_{\text{SS}}$	00			Hex
FSR	Full Scale Reading	Conversion result when $V_{\text{IN}} = V_{\text{DD}}$			FF	Hex
$AD_{\text{I}}$	Analog Input Current During Conversion	$V_{\text{DD}} = 4.5\text{V}$			1.0	$\mu\text{A}$
$AC_{\text{IN}}$	Analog Input Capacitance			2	5	pF

### Notes:

1. Noise at  $V_{\text{DD}}$ ,  $V_{\text{SS}} < 10\text{mV}$
2. With oscillator frequencies less than 1MHz, the A/D Converter accuracy is decreased.

## 6.6 TIMER CHARACTERISTICS

( $T_A = -40$  to  $+85^\circ\text{C}$  unless otherwise specified)

Symbol	Parameter	Test Conditions	Value			Unit
			Min.	Typ.	Max.	
$f_{IN}$	Input Frequency on TIMER Pin*				$\frac{f_{INT}}{8}$	MHz
$t_W$	Pulse Width at TIMER Pin*	$V_{DD} = 3.0V$ $V_{DD} > 4.5V$	1 125			$\mu\text{s}$ ns

Note\*: When available.

## 6.7 SPI CHARACTERISTICS

( $T_A = -40$  to  $+85^\circ\text{C}$  unless otherwise specified)

Symbol	Parameter	Test Conditions	Value			Unit
			Min.	Typ.	Max.	
$F_{CL}$	Clock Frequency	Applied on Scl			1	MHz
$t_{SU}$	Set-up Time	Applied on Sin		50		ns
$t_h$	Hold Time	Applied on Sin		100		ns

## 6.8 LCD ELECTRICAL CHARACTERISTICS

( $T_A = -40$  to  $+85^\circ\text{C}$  unless otherwise specified)

Symbol	Parameter	Test Conditions	Value			Unit
			Min.	Typ.	Max.	
$V_{OS}$	DC Offset Voltage	$V_{LCD} = V_{DD}$ , no load			50	mV
$V_{OH}$	COM High Level, Output Voltage SEG High Level, Output Voltage	$I = 100\mu\text{A}$ , $V_{LCD} = 5V$ $I = 50\mu\text{A}$ , $V_{LCD} = 5V$	4.5			V
$V_{OL}$	COM Low Level, Output Voltage SEG Low Level, Output Voltage	$I = 100\mu\text{A}$ , $V_{LCD} = 5V$ $I = 50\mu\text{A}$ , $V_{LCD} = 5V$			0.5	
$V_{LCD}$	Display Voltage	See Note 2	$V_{DD} - 0.2$		10	

### Notes:

- The DC offset refers to all segment and common outputs. It is the difference between the measured voltage value and nominal value for every voltage level.
- An external resistor network is required when  $V_{LCD}$  is lower than 4.5V.

## 6.9 PSS ELECTRICAL CHARACTERISTICS (When available)

( $T_A = -40$  to  $+85^\circ\text{C}$  unless otherwise specified)

Symbol	Parameter	Test Conditions	Value			Unit
			Min.	Typ.	Max.	
$V_{PSS}$	PSS pin Input Voltage		$V_{SS}$		$V_{DD}$	V
$I_{PSS}$	PSS pin Input Current	$V_{PSS} = 5.0V$ , $T_A = 25^\circ\text{C}$ PSS Running PSS Stopped			350 1	$\mu\text{A}$

## 7 GENERAL INFORMATION

### 7.1 PACKAGE MECHANICAL DATA

Figure 30. 64-Pin Plastic Quad Flat Package

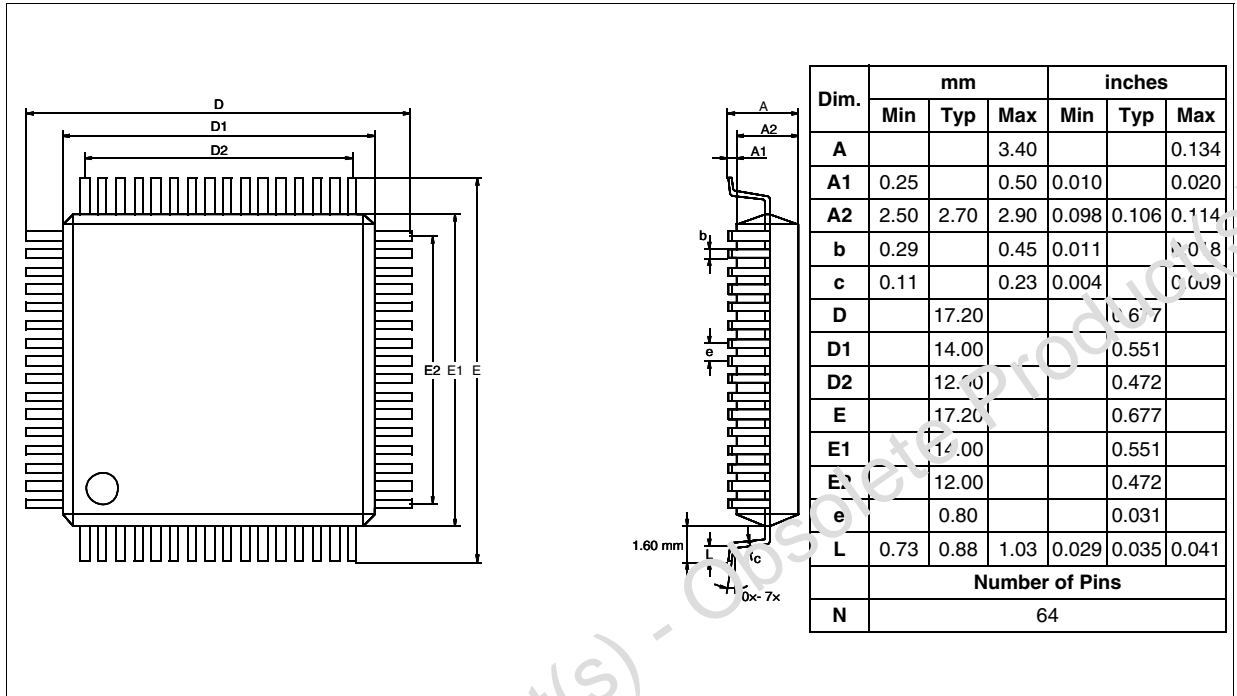
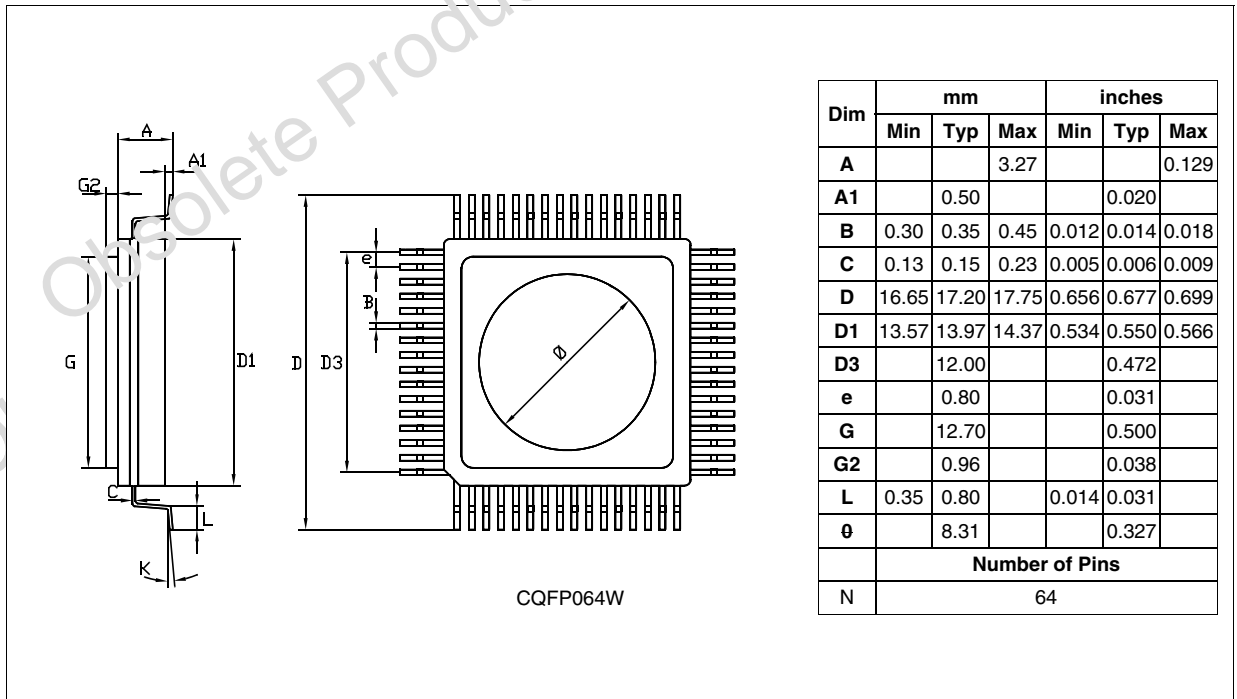

Figure 31. 64-Pin Ceramic Quad Flat Package



## 7.2 PACKAGE THERMAL CHARACTERISTIC

Symbol	Parameter	Test Conditions	Value			Unit
			Min.	Typ.	Max.	
RthJA	Thermal Resistance	PQFP64			70	°C/W
		CQFP64W			70	

## 7.3 ORDERING INFORMATION

Table 27. OTP/EPROM VERSION ORDERING INFORMATION

Sales Type	Program Memory (Bytes)	I/O	Temperature Range	Package
ST62E42BG1	7948 (EPROM)	10 to 18	0 to 70°C	CQFP64W
ST62T42BQ6	7948 (OTP)		-40 to 85°C	PQFP64

## 7.4 IMPORTANT NOTE

For OTP devices, data retention and programmability must be guaranteed by a screening procedure. Refer to Application Note AN886.

Notes:

Q' Obsolete Product(s) - Obsolete Product(s)



# ST6242B

## 8-BIT ROM MCU WITH LCD DRIVER, EEPROM AND A/D CONVERTER

- 3.0 to 6.0V Supply Operating Range
- 8 MHz Maximum Clock Frequency
- -40 to +85°C Operating Temperature Range
- Run, Wait and Stop Modes
- 5 Interrupt Vectors
- Look-up Table capability in Program Memory
- Data Storage in Program Memory:  
User selectable size
- Data RAM: 192 bytes
- Data EEPROM: 128 bytes
- 18 I/O pins, fully programmable as:
  - Input with pull-up resistor
  - Input without pull-up resistor
  - Input with interrupt generation
  - Open-drain or push-pull output
  - Analog Input
  - LCD segments (8 combiport lines)
- 4 I/O lines can sink up to 20mA to drive LEDs or TRIACs directly
- Two 8-bit Timer/Counter with 7-bit programmable prescaler
- Digital Watchdog
- 8-bit A/D Converter with 6 analog inputs
- 8-bit Synchronous Peripheral Interface (SPI)
- LCD driver with 10 segment outputs, 4 backplane outputs and selectable multiplexing ratio.
- On-chip clock oscillator can be driven by Quartz Crystal or Ceramic resonator
- One external Non-Maskable Interrupt
- ST6242-EMU2 Emulation and Development System (connects to an MS-DOS PC via a parallel port).

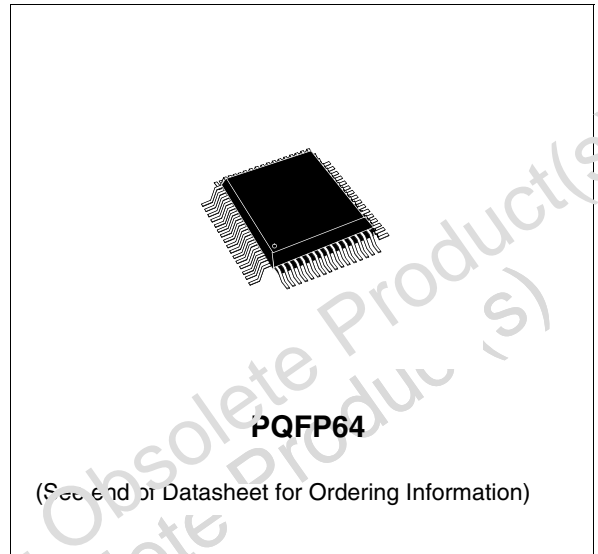

### DEVICE SUMMARY

DEVICE	ROM (Bytes)	I/O Pins
ST6242B	7948	10 to 18

## 1 GENERAL DESCRIPTION

### 1.1 INTRODUCTION

The ST6242B is mask programmed ROM version of ST62T42B OTP devices.

It offers the same functionality as OTP devices, selecting as ROM options the options defined in the programmable option byte of the OTP version.

Figure 1. Programming wave form

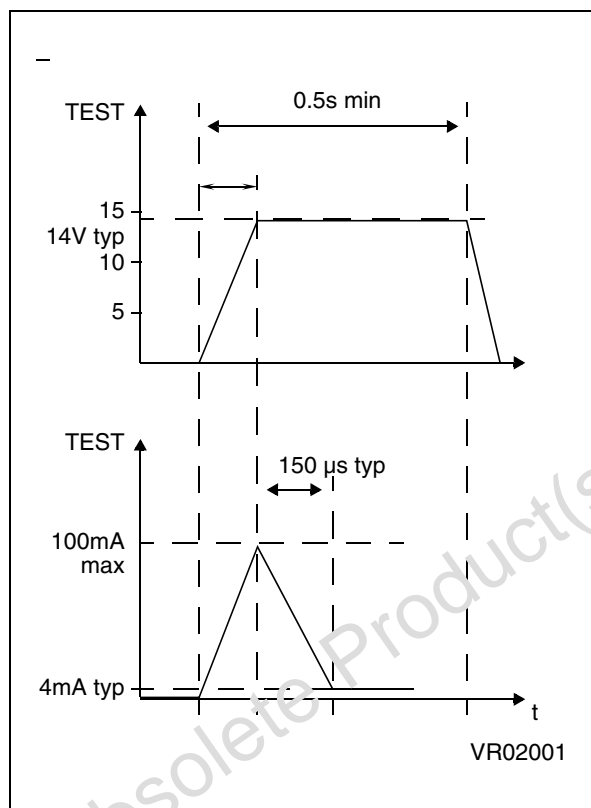

### 1.2 ROM READOUT PROTECTION

If the ROM READOUT PROTECTION option is selected, a protection fuse can be blown to prevent any access to the program memory content.

In case the user wants to blow this fuse, high voltage must be applied on the TEST pin.

Figure 2. Programming Circuit

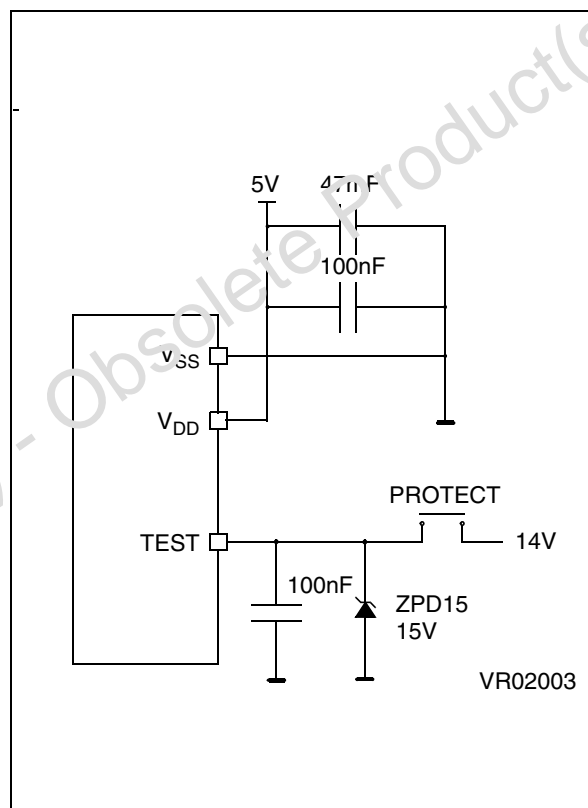

Note: ZPD15 is used for overvoltage protection

**1.3 ORDERING INFORMATION**

The following section deals with the procedure for transfer of customer codes to STMicroelectronics.

**1.3.1 Transfer of Customer Code**

Customer code is made up of the ROM contents and the list of the selected mask options. The ROM contents are to be sent on diskette, or by electronic means, with the hexadecimal file generated by the development tool. All unused bytes must be set to FFh.

The selected mask options are communicated to STMicroelectronics using the correctly filled OPTION LIST appended. See [page 67](#).

**1.3.2 Listing Generation and Verification**

When STMicroelectronics receives the user's ROM contents, a computer listing is generated from it. This listing refers exactly to the mask which will be used to produce the specified MCU. The listing is then returned to the customer who must thoroughly check, complete, sign and return it to STMicroelectronics. The signed listing forms a

**Table 2. ROM version Ordering Information**

Sales Type	ROM	V/C	Temperature Range	Package
ST6242BQ1/XXX	7948	16 to 24	0 to +70°C	PQFP64
ST6242BQ6/XXX			-40 to 85°C	

part of the contractual agreement for the creation of the specific customer mask.

The STMicroelectronics Sales Organization will be pleased to provide detailed information on contractual points.

**Table 1. ROM Memory Map for ST6242B**

ROM Page	Device Address	Description
Page 0	0000h-007Fh 0080h-07FFh	Reserved User ROM
Page 1 "STATIC"	0800h-0F9Fh 0FA0h-0FEFh 0FF0h-0FF7h 0FF8h-0FFBh 0FFCh-0FFDh 0FFEh-0FFFh	User ROM Reserved Interrupt Vectors Reserved NMI Vector Reset Vector
Page 2	0C00h-000Fh 0010h-07FFh	Reserved User ROM
Page 3	0000h-000Fh 0010h-07FFh	Reserved User ROM

### ST6242B MICROCONTROLLER OPTION LIST

Customer: .....

Address: .....

Contact: .....

Phone: .....

Reference: .....

#### STMicroelectronics references:

Device:  ST6242B (8 KB)

Package:  Plastic Quad Flat Package (Tape & Reel)

Temperature Range:  0°C to + 70°C  - 40°C to + 85°C

Marking:  Standard marking  
 Special marking:  
PQFP64 (10 char. max): \_\_\_\_\_

Authorized characters are letters, digits, '.', '/', and spaces only.

Watchdog Selection:  Software Activation  Hardware Activation

Readout Protection:  Enabled:  
 Fuse is blown by STMicroelectronics  
 Fuse can be blown by the customer  
 Disabled

I/O pull-up Selection:  Enabled  Disabled

#### Comments:

Number of segments and backplanes used: .....

Supply Operating Range in the application: .....

Oscillator Frequency in the application: .....

Notes: .....

Date: .....

Signature: .....

## 2 SUMMARY OF CHANGES

Date	Rev.	Main Changes
Jul 2001	2.7	Changed ORB address (CEh instead of CDh) in <a href="#">section 4.1.5 on page 36</a> . Updated Table 18 on page 46. Removed one table: "32KHz Division Factor for base frequency selection" ( <a href="#">section 4.5 on page 46</a> ). Changed <a href="#">Figure 30 on page 61</a> . Changed option list ( <a href="#">page 67</a> ).
Dec 2004	3.0	Added <a href="#">section 7.4 on page 62</a>

**Notes:**

Information furnished is believed to be accurate and reliable. However, STMicroelectronics assumes no responsibility for the consequences of use of such information nor for any infringement of patents or other rights of third parties which may result from its use. No license is granted by implication or otherwise under any patent or patent rights of STMicroelectronics. Specifications mentioned in this publication are subject to change without notice. This publication supersedes and replaces all information previously supplied. STMicroelectronics products are not authorized for use as critical components in life support devices or systems without express written approval of STMicroelectronics.

The ST logo is a registered trademark of STMicroelectronics.

All other names are the property of their respective owners  
© 2004 STMicroelectronics - All rights reserved

STMicroelectronics group of companies

Australia – Belgium - Brazil - Canada - China – Czech Republic - Finland - France - Germany - Hong Kong - India - Israel - Italy - Japan - Malaysia - Malta - Morocco - Singapore - Spain - Sweden - Switzerland - United Kingdom - United States of America

[www.st.com](http://www.st.com)