

A SOLID STATE BLINKER FOR AUTOMOTIVE APPLICATIONS

by Sergio Ciscato

Using dedicated power ICs today it is possible to make a car blinker circuit without relays. The benefits are simpler cabling and better reliability.

Present car direction indicator system generally use a dedicated integrated circuit as the STMicroelectronics L9686 in conjunction with a relay to control the flashing of the lamps. A high current electromechanical switch is necessary to turn on the right or the left direction indicator lamps; to provide the emergency blinker feature a 3-pole power switch is needed too (see Fig. 1).

The first disadvantage of this system is the high number of power connections between the master module and the switches; in addition, the high currents flowing through the switches and across the relay contacts decrease their lifetime and consequently the reliability of the system.

Thanks to smart power devices it is possible to implement a solid state car direction indicator system (see Fig. 2), that solves these problems.

Figure 1. Traditional System

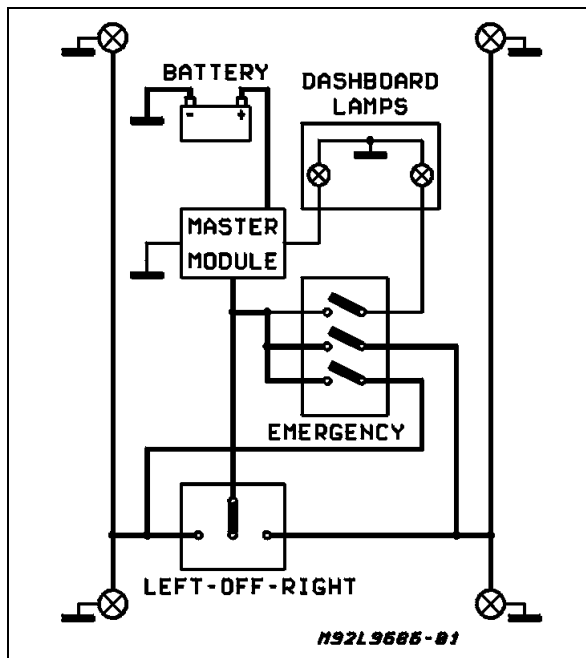
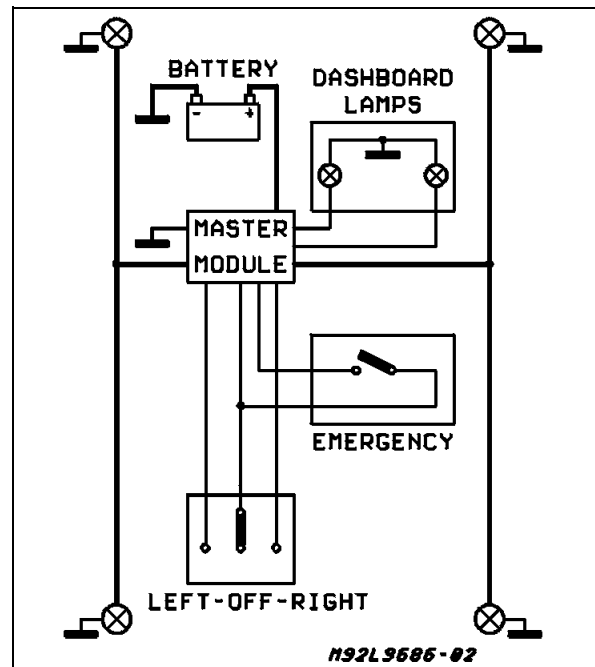

Figure 2. New Solid State System



CIRCUIT DESCRIPTION

The control device in the system described here is the L9686, but the relay is replaced by two L9821 High Side Drivers; this device delivers up to 25A peak output current with $R_{ON} = 100m\Omega$, short circuits and thermal protection.

When a power devices is turned on, the local supply voltage can drop several volt below its nominal value because of the line inductance. This voltage drop could cause disturbances to the control logic that in some cases could produce undamped oscillations on the supply line itself.

To avoid these oscillations and to prevent EMI disturbances, the L9821 was chosen as the power device in this applications because of a feature

AN454 APPLICATION NOTE

that limits the output current slew rate (di/dt) during the switching edges.

Fig. 3 and Fig. 4 show the rising and the falling edges of the output current of an L9821 device loaded with two 21W lamps; the current level in the first case is higher than in the second one because of the inrush current of the bulbs (see Fig. 5).

Figure 3. Rising Edge of the Output Current

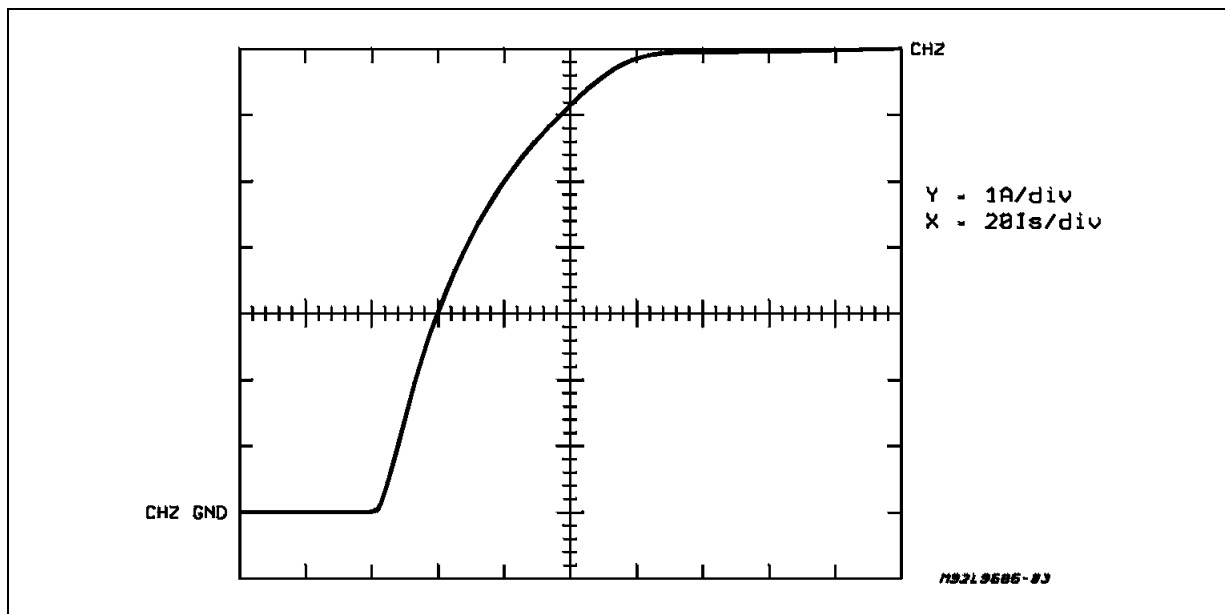

Figure 4. Falling Edge of the Output Current

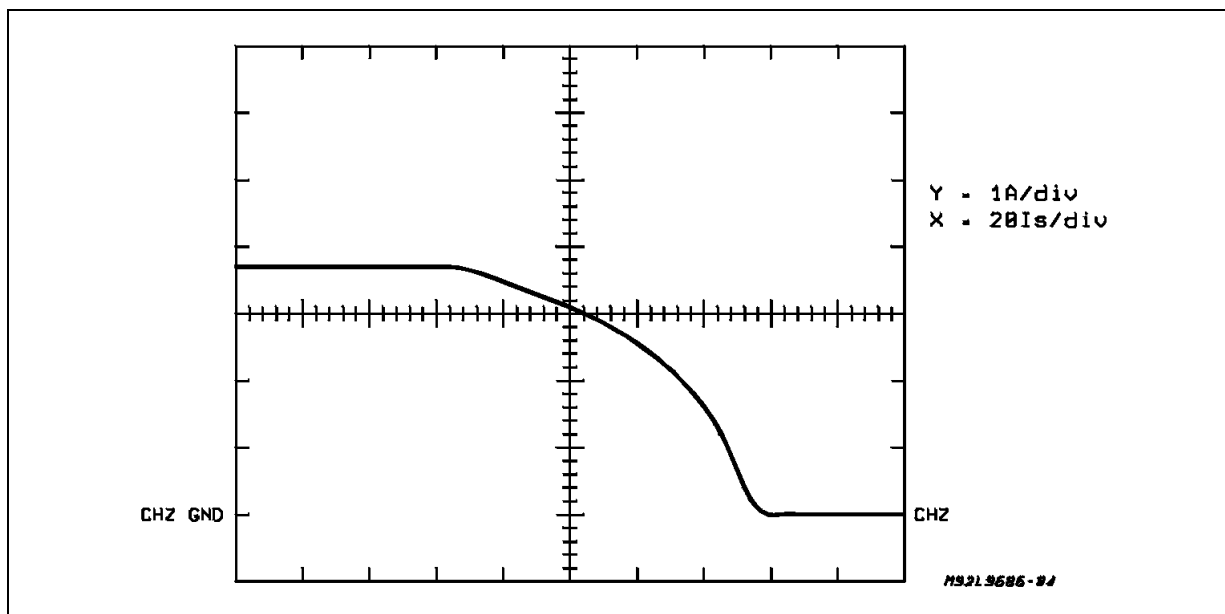
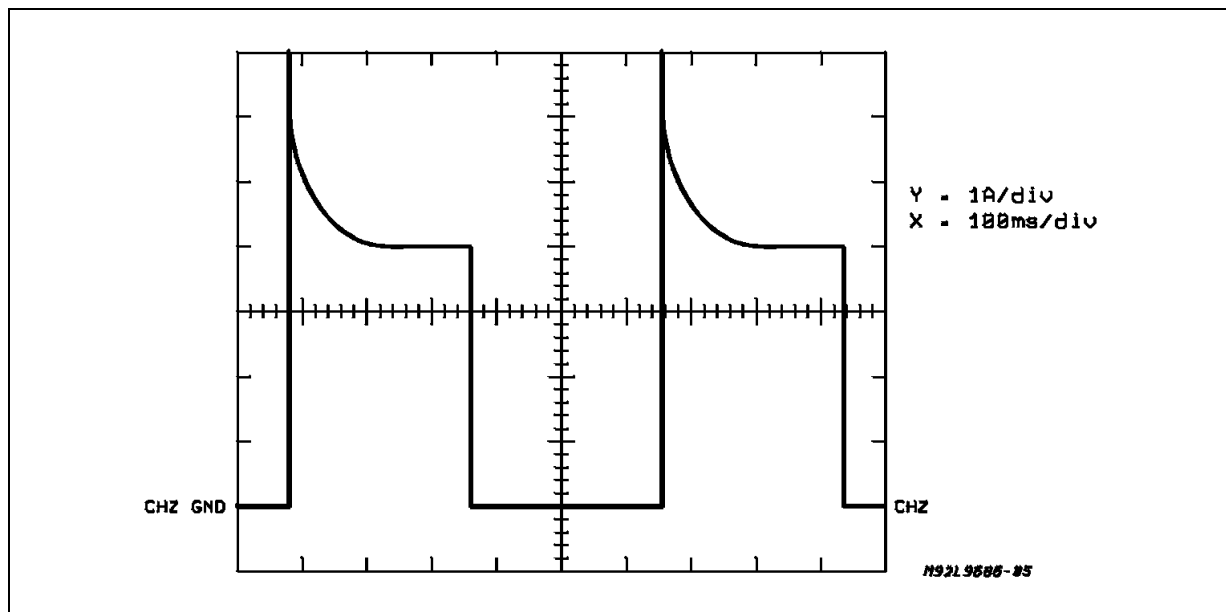

Fig. 6 shows the complete schematic diagram of the master module: when S1 is closed (left or right) the L9686.s internal oscillator starts and pin 3 goes high; then the input voltage of one of the two L9821 devices goes high too, resulting in the lamps switching on. After a time equal to half of the oscillation period pin 3 of the L9686 returns low and the lamps are therefore switched off.

Figure 5. Output Current Waveform



The flashing cycle stops and the circuit is reset to the initial conditions when S1 is open. The flashing frequency depends on the external RC network R1 and C1 according to the following formula:

$$F_n = 1 / (1.5 \times R1 \times C1) \text{ (typ.)}$$

R3 and C2 provide hysteresis to avoid spurious switching of the oscillator comparator at every lamp turn on; this hysteresis is not necessary if the L9686 is used in conjunction with a relay, because of the relatively long delay time of this last one. R_{shunt} senses the current flowing in the right or the left lamps (depending on the S1 position): when one of the lamps is defective the voltage drop across R_{shunt} is reduced to a half and the failure is indicated by doubling the flashing frequency. S2 allows the emergency blinker function: when it is closed the L9686 device drives, through the diodes D1 and D2, both the L9821 smart switches and then both the right and the left lamps.

The emergency blinker operation is monitored by the flashing of both the dashboard lamps L1 and L2 while in normal operation only L2 flashes.

OVERVOLTAGE PROTECTION

An L9821 device can withstand up to 60V load dump transient. If a centralized overvoltage protection is not provided on the alternator it is possible to increase the load dump capability of this application by placing a dedicated protection device, such as a Transil, between the supply voltage and the ground terminals. This transil must withstand the double battery, a condition often requested for the automotive equipment, so a good choice is a device with at least 26V breakdown voltage. The same protection device allows the described application to withstand all the other voltage transients. If a centralized load dump protection device is already present on the alternator a small protection zener diode is sufficient to clamp the low energy overvoltage transients due to the disconnection of the several loads in the car. In this case the breakdown voltage of the local protection device must be higher than the clamping voltage of the centralized diode.

ADVANTAGES

Fig. 2 shows a possible wiring diagram of the described system in a car; the master module has 10 connections, compared to the four of the conventional system showed in Fig. 1, but from the comparison between the two possibilities we can see some advantages:

AN454 APPLICATION NOTE

- centralized wiring at the master module
- less power connections
- less power wire length
- no power switches
- no multipolar switch for the emergency blinker
- short circuit protection between the lamps and ground
- inrush current limiting of the smart switches increases the lamps lifetime

Figure 6. Schematic Diagram

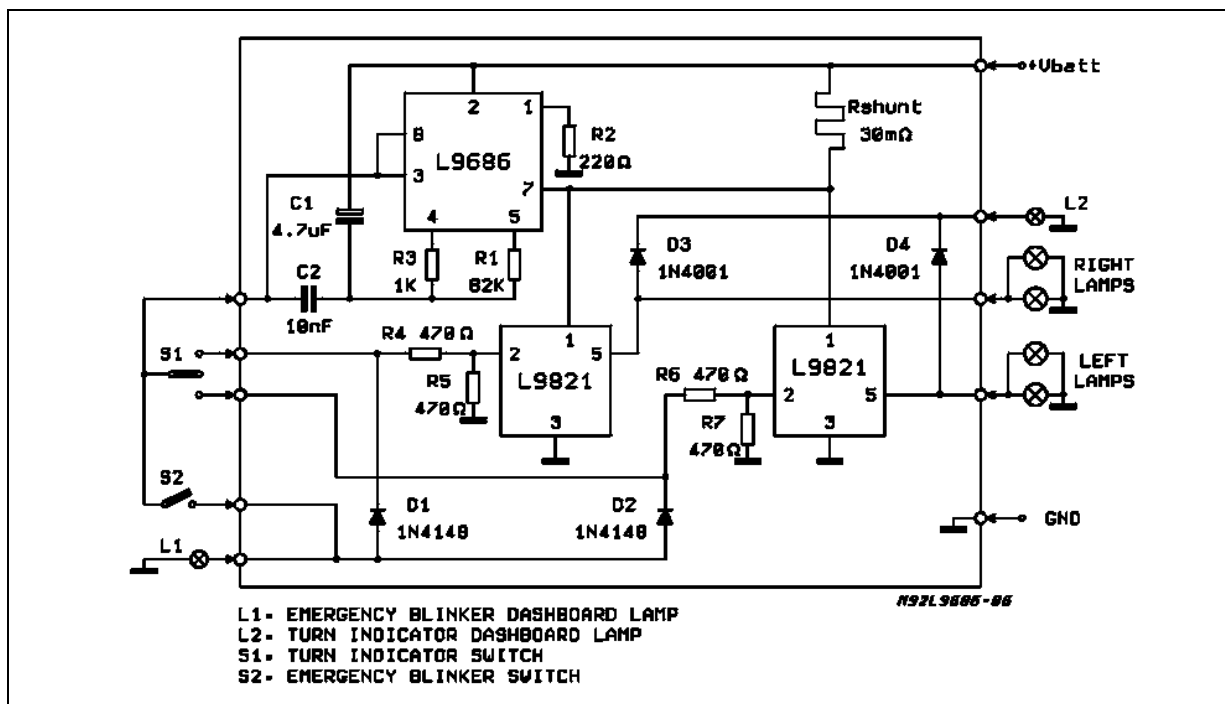

Information furnished is believed to be accurate and reliable. However, STMicroelectronics assumes no responsibility for the consequences of use of such information nor for any infringement of patents or other rights of third parties which may result from its use. No license is granted by implication or otherwise under any patent or patent rights of STMicroelectronics. Specifications mentioned in this publication are subject to change without notice. This publication supersedes and replaces all information previously supplied. STMicroelectronics products are not authorized for use as critical components in life support devices or systems without express written approval of STMicroelectronics.

The ST logo is a registered trademark of STMicroelectronics.
 All other names are the property of their respective owners

© 2003 STMicroelectronics - All rights reserved

STMicroelectronics GROUP OF COMPANIES

Australia - Belgium - Brazil - Canada - China - Czech Republic - Finland - France - Germany - Hong Kong - India - Israel - Italy - Japan - Malaysia - Malta - Morocco - Singapore - Spain - Sweden - Switzerland - United Kingdom - United States
www.st.com