

6A DOOR LOCK MOTOR DRIVER FOR AUTOMOTIVE

by Stefano Vergani

An application of the L9937 device (Full Bridge Motor Drive) is described. The interface between the L9937 and a μC is discussed. A complete protections circuitry description is also given.

The L9937 device is a full bridge for bidirectional motor driver applications realized in bipolar technology; it can deliver up to 6A output current with low saturation voltage.

Two diagnostic informations are provided to monitor overload conditions and the internal temperature, and the device is assembled in the MULTI-WATT-11 package with the case connected to the ground terminal. The L9937 is particularly suitable to drive bidirectional DC motors in μC based systems.

Fig. 1 shows a possible application circuit, with an analog interface between the power devices and the μC . In the following, the functions of each block of the analog interface are described.

1. OVERVOLTAGE AND REVERSE BATTERY PROTECTION

L9937 is particularly suitable to drive the door lock motors in automotive applications. Fig. 2 shows the circuit schematics; due to the hostile automotive environment, it is necessary a transil (suggested type LDP24A) between VD and GND, to protect the L9937 against overvoltages higher than 50V. The diode D1 suggested type BY239-200A) supplies the voltage VD necessary for the correct device's operation at the same time it protects the device against the reverse battery.

Figure 1.

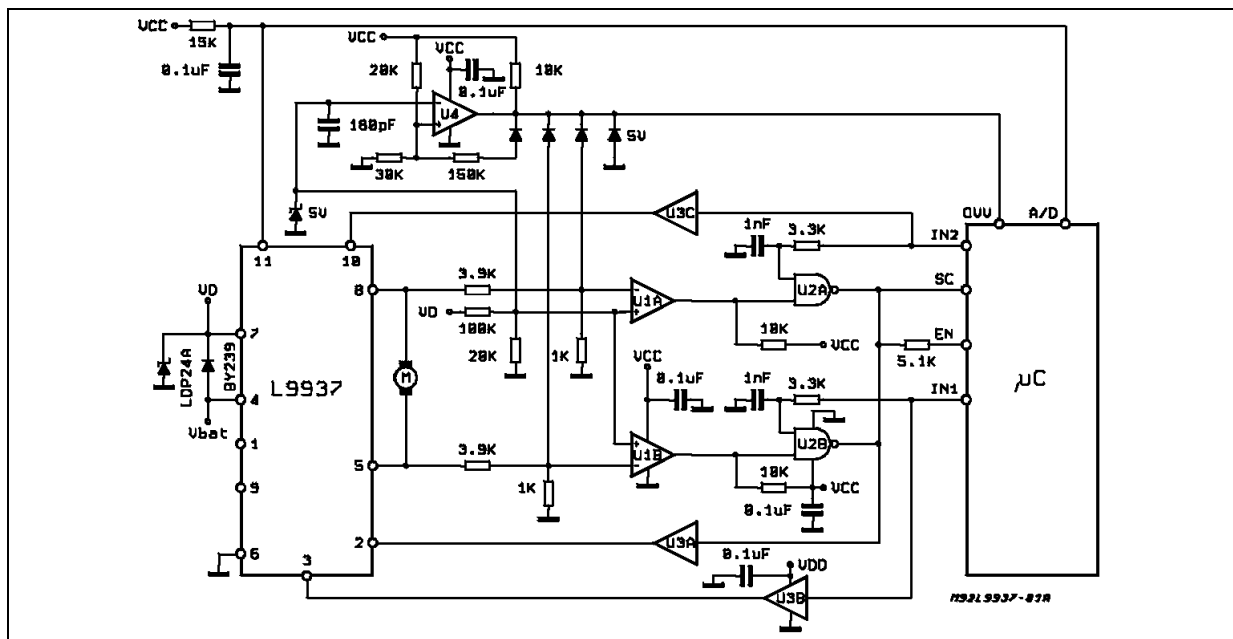
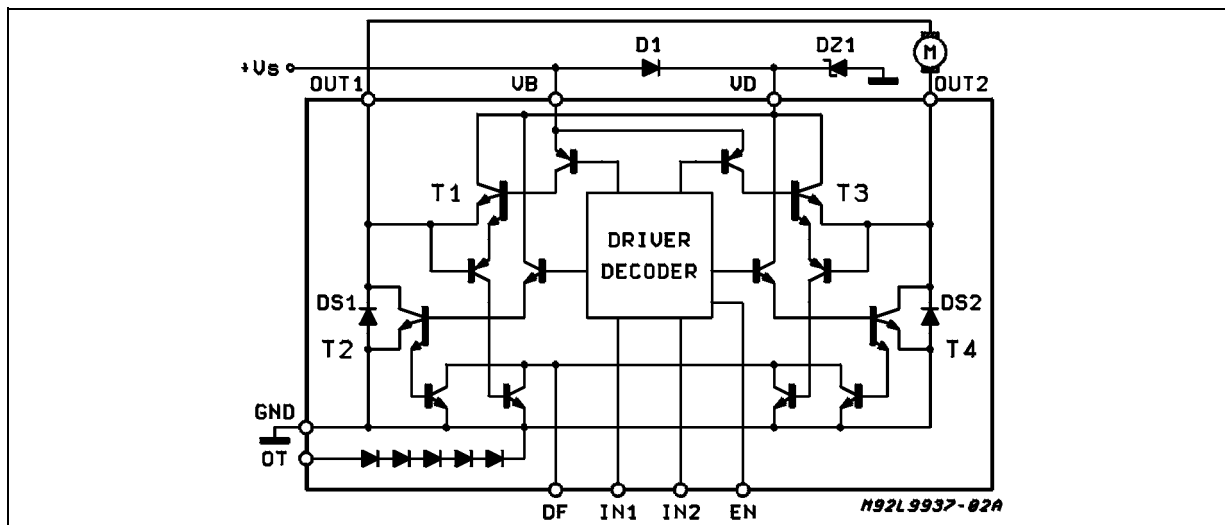

Figure 2.



2. SWITCH-OFF SEQUENCE

Referring to Fig. 2 and supposing i.e. T1 and T4 ON, T2 and T3 OFF (this means EN=H IN1=H IN2=L), the following steps have to be observed to allow a correct recirculation of the current in the motor at the switch off (Ref. Fig. 3):

- a) switch off T1 and wait for 100µs about in this condition (EN = L IN1 = H IN2 = L)
- b) after the a.m. delay switch ON T2 (EN = L IN1 = H IN2 = H)
- c) switch off both T2 and T4 after the motor stop (EN = L IN1= L IN2 = L)

Step a) allows the recirculation of the motor current due to the inductive component of the motor itself between DS1 and T4; the 100µsec delay time is needed to avoid the cross-conduction in the left half bridge. In step b) the motor is short circuited to GND (T2 and T4 ON) and this allows the dynamic braking. In step c) T1, T2, T3 and T4 are OFF to allow a very low current consumption of the bridge. If the dynamic braking is not requested, step b) can be omitted. In any case the lower power transistor of an half bridge must be kept ON, after the switch off of the upper transistor of the other half bridge, for a time longer than $T = 5 \cdot R_L/L_L$, where R_L and L_L are the resistance and the inductance of the load.

Figure 3. Switch-off Sequence

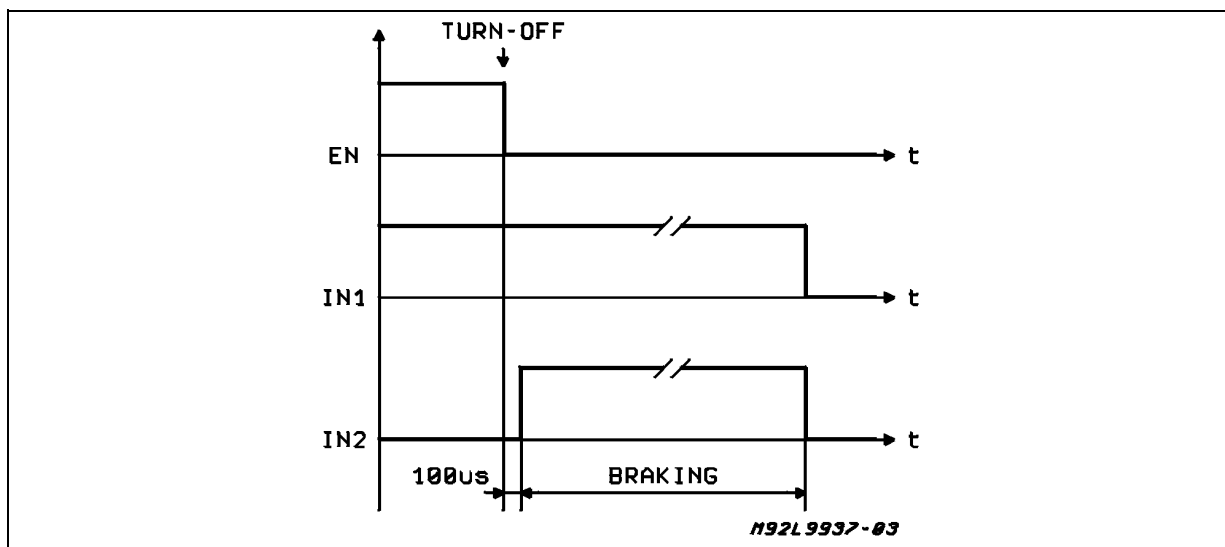

3. INPUT DRIVING VOLTAGE

To allow a correct operation of L9937 over the full temperature range, the driving voltage at the input pins must be higher than 5.5V, with 4mA current capability.

4. SHORT CIRCUIT PROTECTION

It is possible to protect L9937 against short circuit to ground and across the motor in the full bridge application. The circuit schematics shown in Fig. 4 uses two voltage comparators (U1A, U1B) to detect the V_{ce} of the upper power transistors. U2A and U2B are open drain NAND gates (i.e. part no. HCC40107) and U3A/B/C/D are non inverting buffer to drive the L9937 (i.e. part no. 74HC4050).

U1A and U1B sense the differential voltage V_{D-OUT2} and V_{D-OUT1} respectively. Referring to Fig. 4, chosen $R1=100K$ and $R2=20K$, the values of $R3$ and $R4$ may be calculated according to the following formula:

$$R3 = \frac{(V_D - V_{CETH}) - 0.166V_D}{0.166V_D} \cdot R4$$

where :

V_D = bridge power supply

V_{CETH} = collector to emitter detection threshold.

Choosing:

$V_{CETH} = 2V$ @ $V_D = 12V$ and $R4 = 1K$, the above formula gives $R3 = 4K$.

When all signals from μC are at low level (motor off), the inputs to the bridge are low too; in these conditions the output voltage of the two comparators is high and therefore the outputs of U2A/U2B are free. When the μC sends, for example, IN2 and EN high, OUT2 of the bridge goes high and OUT1 goes low.

At this point the output of U1A pulls down the input of U2A before that the delay capacitor C1 is charged (through R5) up to the U2A threshold; in this way the U2A output remains free and the bridge drives the motor.

If a short circuit occurs, the V_{ce} of the upper power transistor increases above the threshold and then the U2A output pulls down the enable input of L9937. At the SDME time the SC signal to μC , high in normal conditions, goes low; at this point the μC executes the switch-off sequence. We have just explained what happens when a short circuit occurs during the motor running phase. Another faulting condition occurs switching on the bridge when a short circuit is present; in this case the bridge is driven for a time depending on the time constant $R5 \cdot C1 = R6 \cdot C2$. Choosing $R5 = R6 = 3.3K$ and $C1 = C2 = 1nF$, then the time constant will be $T = 3.3\mu sec$, that is $5\mu sec$ about delay time. Longer delay time might allow the short circuit current to reach values beyond the absolute maximum ratings.

Figure 4.

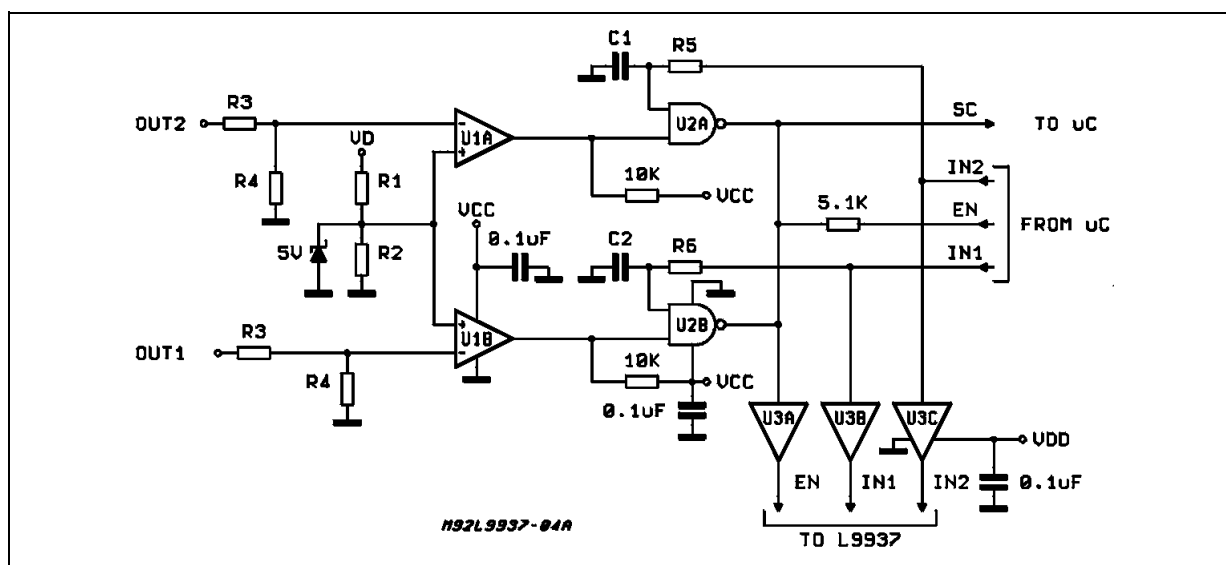

5. THERMAL PROTECTION

The L9937 has 5 built-in diodes series-connected that can be used to implement a thermal protection for the device.

Fig. 5 shows the relationship between the voltage across the diodes and the temperature at 100µA diode current.

Figure 5.

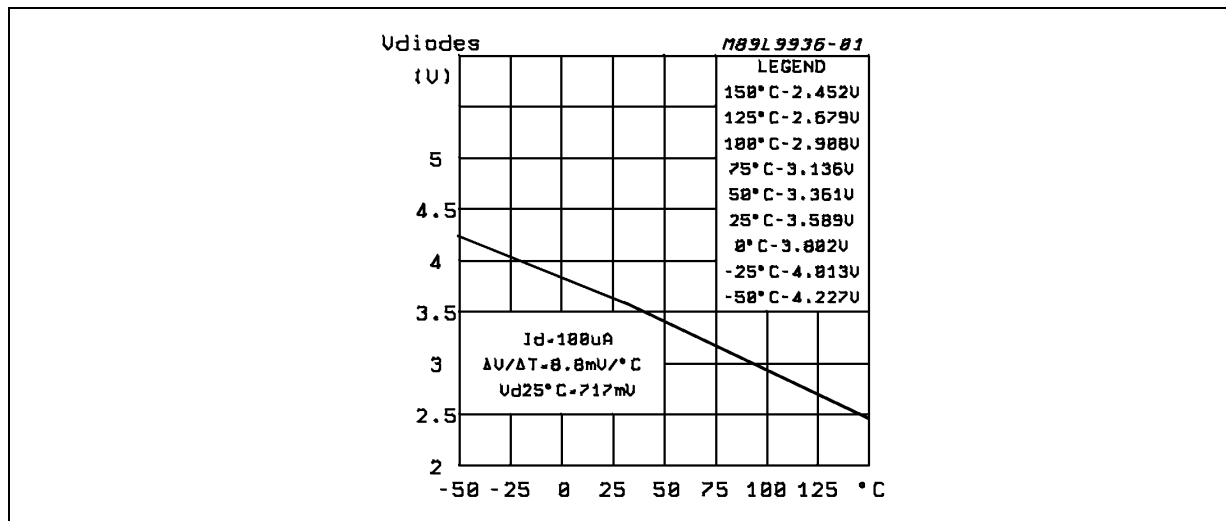
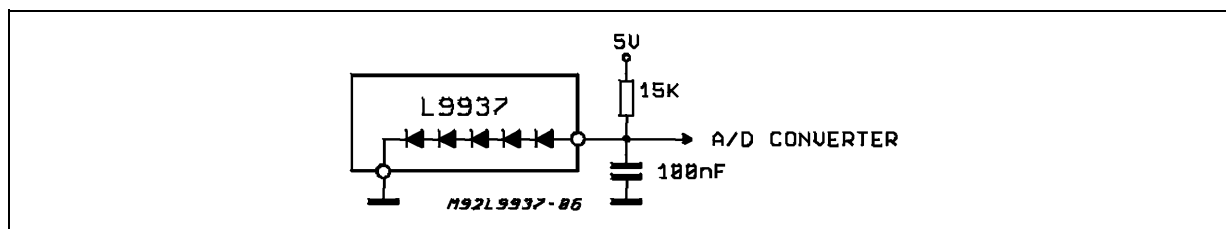

Fig. 6 shows the simplest solution to do a thermal protection; an A/D converter of the µC is used to detect the voltage drop across the 5 diodes. The 15K resistor sets the current in the diodes and the 100nF capacitor acts as a filter against the noise. When the µC detects a voltage lower than the low threshold chosen according to the diagram in Fig. 5, it executes the switch-off sequence and rejects any command to the bridge until the diodes voltage increases beyond the high threshold. The recommended hysteresis value is 30°C.

Figure 6.



6. OVERVOLTAGE PROTECTION

At point 1 we suggest a way to protect the L9937 against the voltage transients. This protection allows the device to withstand overvoltages only if the bridge is not operating. To protect the device against the overvoltages in all the operating conditions it is possible to implement the circuit shown in Fig. 7.

(Note: A-B are connected to the nodes between R3 and R4 (left side and right side) in Fig. 4; C is connected to the node between R1 and R2 in Fig. 4). When VD reaches 18V the comparator output pulls down A and B, causing the intervention of the hardware protection showed in Fig. 4; at the same time the OVV signal is sent to µC, which executes the switch off sequence. The µC must reject any command to the bridge during the overvoltage conditions.

With the values shown in Fig. 7, a 1V hysteresis is provided.

It is possible to enhance the performances of the system just described avoiding the braking of the motor also for short duration voltage transients; to do this the µC, once received the overvoltage diagnostic sig-

nal (OVV), put at low level the enable of the L9937, confirming the hardware switch-off of the motor; in this condition an output of the half bridge is in high impedance state and the other one is low, allowing the recirculation of the current and the free running of the motor.

The system holds this condition until OVV is active; when the OVV signal is released the μC resets the hardware protection, sending $\text{EN} = \text{IN1} = \text{IN2} = \text{L}$ and then restore the previous command to the bridge.

It is mandatory, however, to wait for the complete current recirculation of the motor before to reset the hardware protection; in facts, when $\text{EN} = \text{IN1} = \text{IN2} = \text{L}$ both the L9937 outputs are in high impedance conditions.

Figure 7.

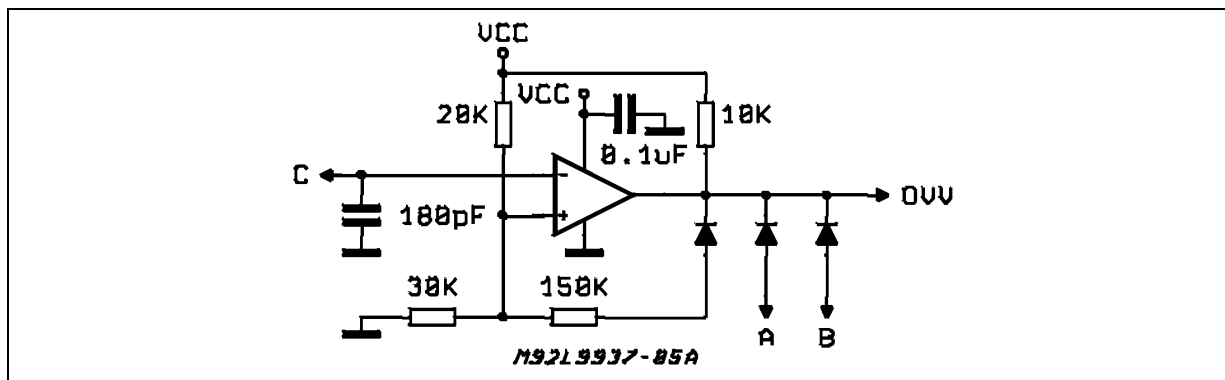

R3 and R4 (left side and right side) in Fig. 4; C is connected to the node between R1 and R2 in Fig. 4). When VD reaches 18V the comparator output pulls down A and B, causing the intervention of the hardware protection showed in Fig. 4; at the same time the OVV signal is sent to μC , which executes the switch off sequence. The μC must reject any command to the bridge during the overvoltage conditions.

With the values shown in Fig. 7, a 1V hysteresis is provided.

It is possible to enhance the performances of the system just described avoiding the braking of the motor also for short duration voltage transients; to do this the μC , once received the overvoltage diagnostic signal (OVV), put at low level the enable of the L9937, confirming the hardware switch-off of the motor; in this condition an output of the half bridge is in high impedance state and the other one is low, allowing the recirculation of the current and the free running of the motor.

The system holds this condition until OVV is active; when the OVV signal is released the μC resets the hardware protection, sending $\text{EN} = \text{IN1} = \text{IN2} = \text{L}$ and then restore the previous command to the bridge.

It is mandatory, however, to wait for the complete current recirculation of the motor before to reset the hardware protection; in facts, when $\text{EN} = \text{IN1} = \text{IN2} = \text{L}$ both the L9937 outputs are in high impedance conditions.

7. DIAGNOSTIC FEEDBACK OUTPUT

DF pin is an open drain output to monitor overcurrent and overtemperature conditions.

The overcurrent detection threshold is inversely dependent from the temperature of the chip. Typical application of this function is to send the DF signal, with an external pull-up to Vcc, to a digital input of the μC ; when the DF signal goes at low level, the μC executes the switch-off sequence.

L9937 IN A BODY MULTIPLEX ENVIRONMENT

All the functions described above can be implemented in a custom integrated circuit together with a bus transceiver and a protocol handler.

It is then possible to obtain a very small size module that can be integrated directly in the actuator. Fig. 8 shows a typical application of these modules as peripheral units in a "Class A" wired Multiplex System.

Figure 8. "Class A" Wired Peripheral Application

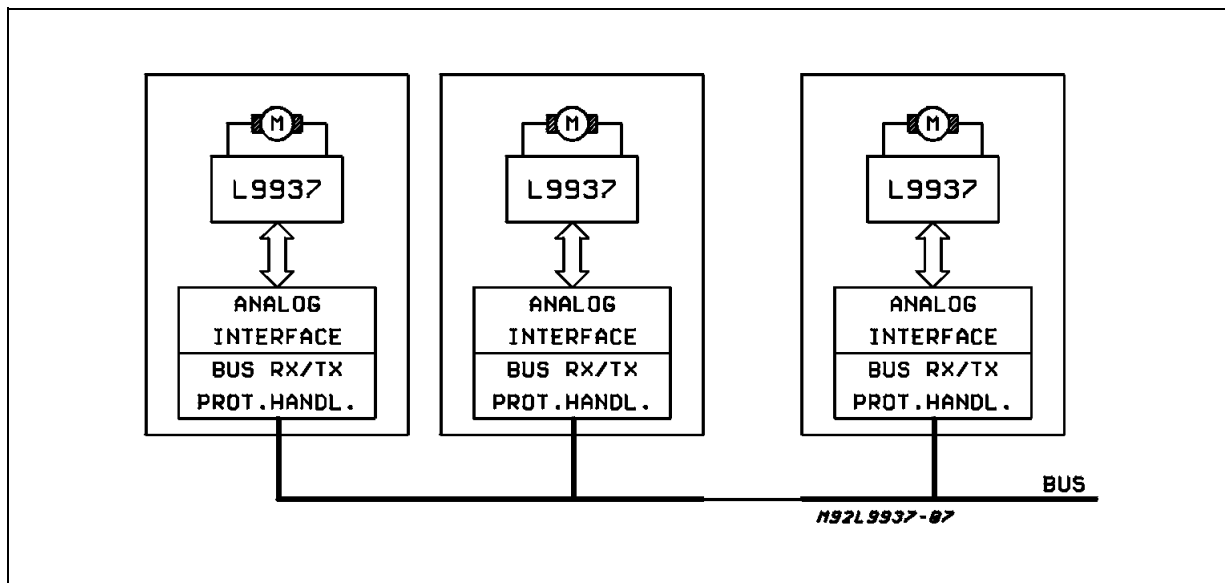

Information furnished is believed to be accurate and reliable. However, STMicroelectronics assumes no responsibility for the consequences of use of such information nor for any infringement of patents or other rights of third parties which may result from its use. No license is granted by implication or otherwise under any patent or patent rights of STMicroelectronics. Specifications mentioned in this publication are subject to change without notice. This publication supersedes and replaces all information previously supplied. STMicroelectronics products are not authorized for use as critical components in life support devices or systems without express written approval of STMicroelectronics.

The ST logo is a registered trademark of STMicroelectronics.
All other names are the property of their respective owners

© 2003 STMicroelectronics - All rights reserved

STMicroelectronics GROUP OF COMPANIES

Australia - Belgium - Brazil - Canada - China - Czech Republic - Finland - France - Germany - Hong Kong - India - Israel - Italy - Japan - Malaysia - Malta - Morocco - Singapore - Spain - Sweden - Switzerland - United Kingdom - United States

www.st.com