

QII and QIII TRIAC triggering with positive power supply

Introduction

New TRIACs with high commutation and dv/dt performances are now available on the market.

Generally these TRIACs can be triggered only in the first three quadrants (case of Snubberless™, logic level and Snubberless high temperature TRIACs) as shown in [Figure 1](#).

This paper describes a trigger circuit supplying a negative gate current for quadrants II and III implemented in a system using a positive power supply.

Without a new design, just by adding a capacitor and a diode, new series TRIACs can replace conventional TRIACs.

Figure 1. The quadrants of Snubberless, logic-level, and Snubberless high temperature TRIACs

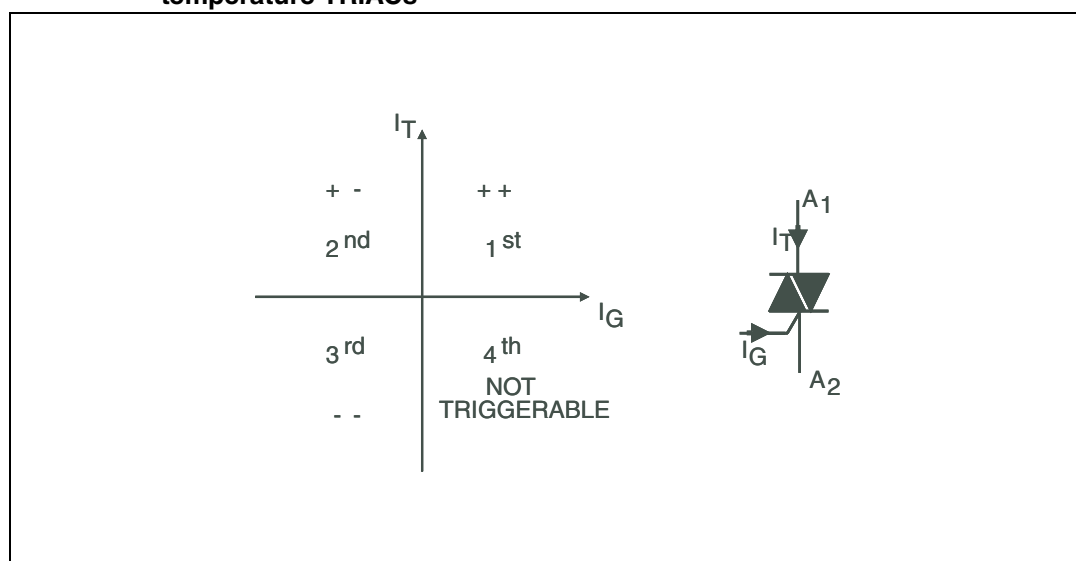

TM: Snubberless is a trademark of STMicroelectronics

1 Principle of proposed gate circuit

To drive the TRIAC in the 2nd and 3rd quadrants, a discharge capacitor is used as shown in [Figure 2](#).

Figure 2. Basic diagram of the triggering circuit

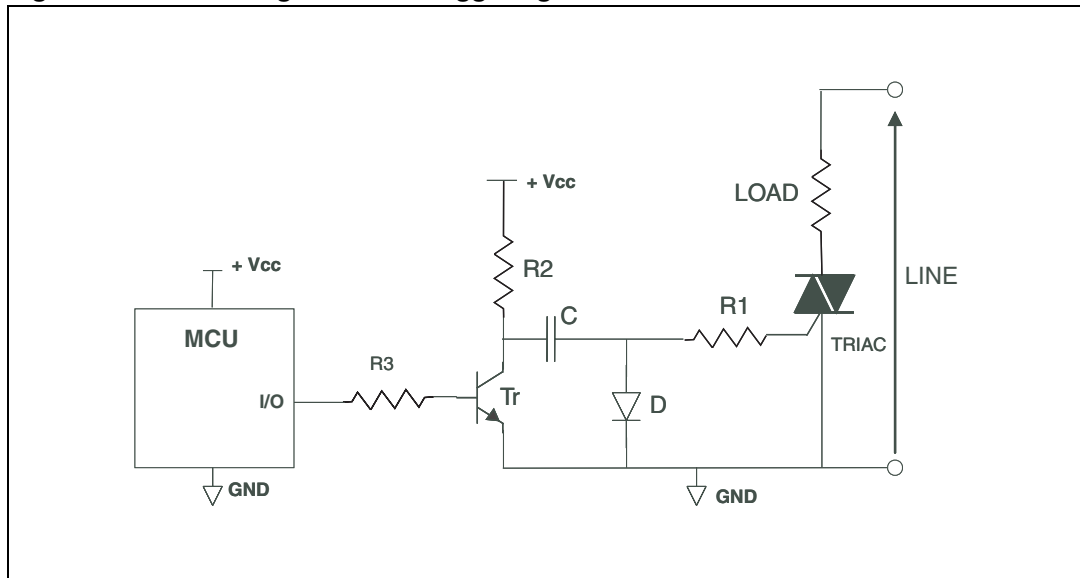

When the transistor Tr is switched off, capacitor C is charged through resistance R2 and diode D. The diode is used to avoid a capacitor charging current through the TRIAC gate. A Schottky diode could be used to keep the voltage drop level below the gate non trigger voltage (V_{GD}). When the TRIAC is triggered, Tr transistor is switched on, C is discharged through R1 and Tr and a negative current flows through the TRIAC gate.

We have to consider different parameters to define all the components:

- The TRIAC gate triggering current (I_{GT}).
- The time duration of the gate current pulse.
- The TRIAC latching current (I_L) especially for low rms current loads.

2 Gate current pulse width setting

The TRIAC latching current (I_L) is the minimum value of the main current which allows the component to remain in the conducting state after the gate current I_G has been removed.

That is to say the gate current has to be higher than I_{GT} until the main current reaches the latching current.

Example: for most of CW Snubberless TRIACs (refer to datasheet for further information):

Q1 – Q3: I_L max = 50 mA

Q2: I_L max = 60 mA

Example: for most BW Snubberless TRIACs:

Q1 – Q3: I_L max = 70 mA

Q2: I_L max = 80 mA

Figure 3. Gate control principle

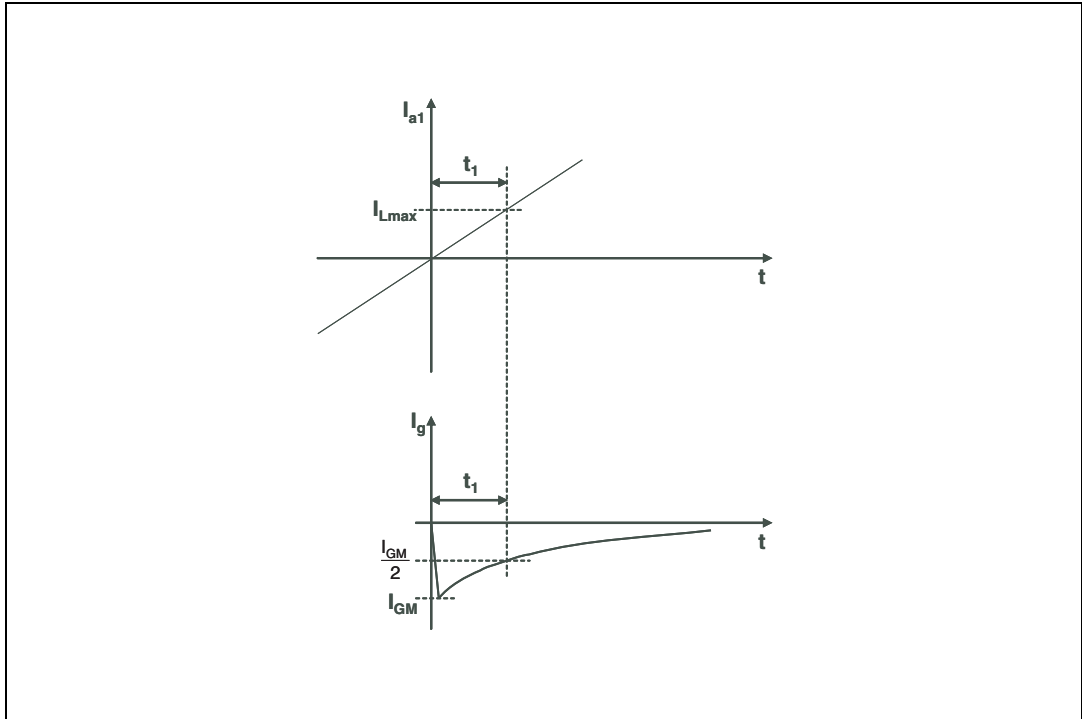

t₁ calculation

The TRIAC gate has to be supplied to reach an anode current higher than the latching current. Furthermore, a minimum gate current pulse width of 20 μs has to be ensured. The minimum t₁ level is then given by the following equation:

$$t_1 \geq \frac{1}{\omega} \operatorname{asin} \left(\frac{I_{L \text{ MAX}}}{I_{RMS} \sqrt{2}} \right) + 20 \mu\text{s}$$

Where $\omega = 2.\pi.f$ and f is mains frequency.

I_{RMS}: minimum rms current of the load (depending on line and load variations).

Figure 4 shows the minimum time versus I_{RMS} load current for a 50Hz application.

Figure 4. t₁ time versus I_{RMS} for different load currents (worst case: ILQ2)

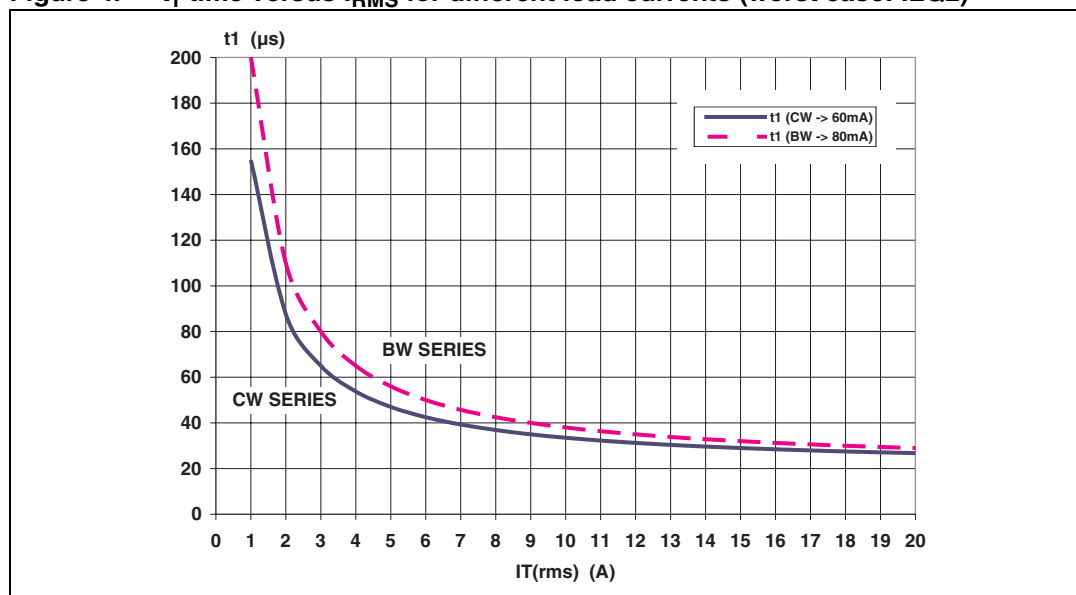

Note: Curve given for V_{CE} = 1 V and V_{GK} = 1.3 V

I_{GT} is the maximum gate trigger current specified in the data sheet. To ensure a good safety margin and a good triggering we chose I_{GM} = 2.I_{GT}.

The gate resistor can be defined by the following equation:

$$R_1 = \frac{V_{CC} - V_{GK} - V_{CE}}{I_{GM}}$$

with typically V_{CE} = 1 V and V_{GK} = 1.3 V at I_{GM} = 2.I_{GT}

Capacitor C is then given by the following equation (where t₁ is given by Figure 4):

$$C \geq \frac{t_1}{R_1 \cdot \ln(2)}$$

Figure 5 gives the minimum capacitance versus supply voltage for different TRIACs series.

To ensure that capacitor C will be charged for the next half cycle, R₂ could be chosen with this equation (charging time constant < 1 ms):

$$R_2 < \frac{0.001}{C}$$

Figure 5. Capacitance value versus supply voltage for different sensitivities

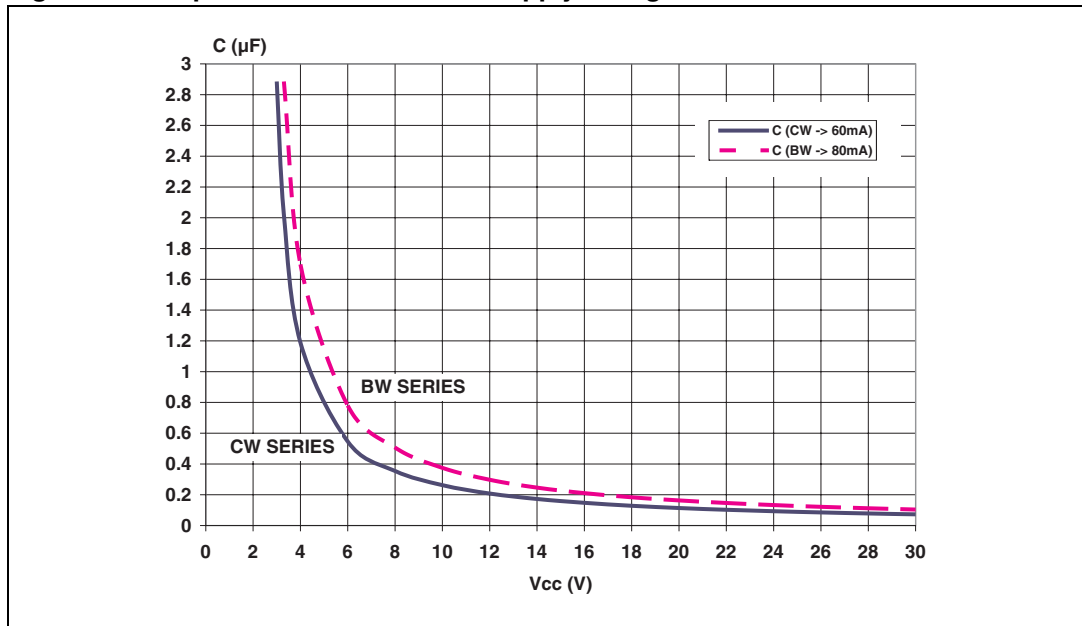

3 Experimental results

Figure 6 gives a typical oscillogram within the following conditions:

- TRIAC = BTA08-600CW
- $I_{RMS} = 2.12 \text{ A}$ (load power: 500 W)
- Line voltage: 230 V rms, 50 Hz
- $V_{CC} = 5 \text{ V}$
- $R_1 = 36 \ \Omega$
- $R_2 = 300 \ \Omega$
- $C = 3.3 \ \mu\text{F}$

Figure 6. Triggering at zero current

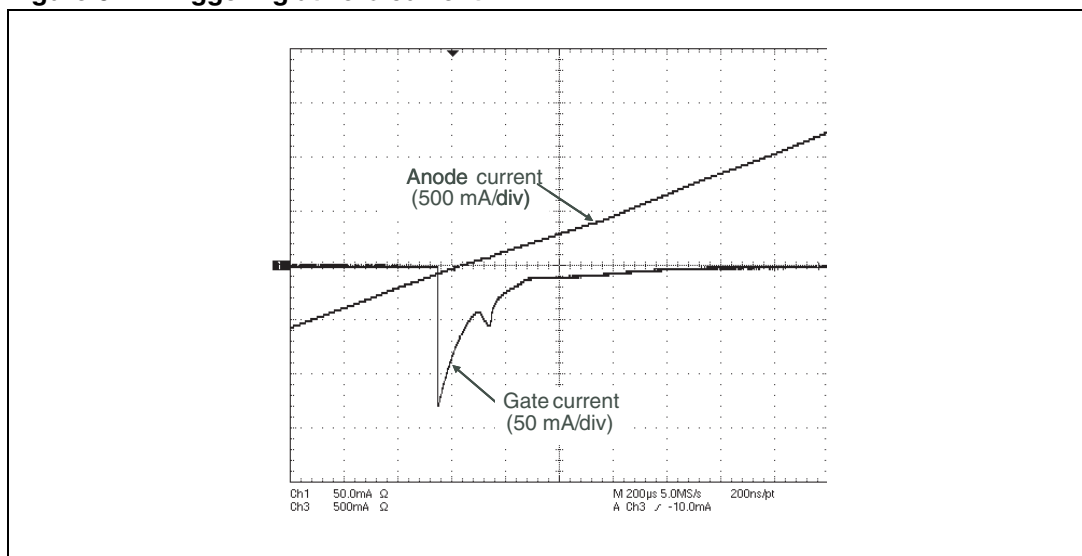

The component values are given in the following table for different application cases.

Table 1. Component values for 3 different cases. TRIAC: BTA08-600CW ($I_{GT} = 35 \text{ mA}$)

	$I_{RMS} = 2 \text{ A}$ $V_{cc} = 5 \text{ V}$	$I_{RMS} = 5 \text{ A}$ $V_{cc} = 5 \text{ V}$	$I_{RMS} = 5 \text{ A}$ $V_{cc} = 10 \text{ V}$
$t_{1MIN} (\mu\text{s})$	87.5	47	47
$R_{1MAX} (\Omega)$	39	39	110
$C_{MIN} (\mu\text{F})$	3.3	1.76	0.62
$R_{2MAX} (\Omega)$	306	569	1622

4 Conclusion

In the case of controllers supplied by positive voltage this solution allows the replacement of conventional TRIACs used in the 1st and 4th quadrants by Snubberless or LOGIC LEVEL TRIACs which operate only in the first three quadrants. This solution only requires the addition of a capacitor and a diode to control each TRIAC.

With inductive loads (motor, transformer, etc...) a pulse train can be used because of the phase lag between current and voltage.

In the case of logic or transistor failure, the capacitor C operates as an open circuit for dc current and avoids all triggering. This factor acts as a safety feature.

But this trigger circuit can not be effectively used to drive small loads (like valves, fan etc...) because the latching current value is quite high compared to the load current. In this case a dc gate current is required.

Then the V_{CC} point of the power supply should be connected to A_1 to sink the current directly from the gate with the control circuit. There is then no need of a supplementary capacitor and diode. This solution is then easier and cheaper.

5 Revision history

Table 2. Document revision history

Date	Revision	Changes
May-1992	1	Initial release.
23-Apr-2004	2	Style sheet update. No Content change.
10-Mar-2008	3	Reformatted to current standards. Full technical review

Please Read Carefully:

Information in this document is provided solely in connection with ST products. STMicroelectronics NV and its subsidiaries ("ST") reserve the right to make changes, corrections, modifications or improvements, to this document, and the products and services described herein at any time, without notice.

All ST products are sold pursuant to ST's terms and conditions of sale.

Purchasers are solely responsible for the choice, selection and use of the ST products and services described herein, and ST assumes no liability whatsoever relating to the choice, selection or use of the ST products and services described herein.

No license, express or implied, by estoppel or otherwise, to any intellectual property rights is granted under this document. If any part of this document refers to any third party products or services it shall not be deemed a license grant by ST for the use of such third party products or services, or any intellectual property contained therein or considered as a warranty covering the use in any manner whatsoever of such third party products or services or any intellectual property contained therein.

UNLESS OTHERWISE SET FORTH IN ST'S TERMS AND CONDITIONS OF SALE ST DISCLAIMS ANY EXPRESS OR IMPLIED WARRANTY WITH RESPECT TO THE USE AND/OR SALE OF ST PRODUCTS INCLUDING WITHOUT LIMITATION IMPLIED WARRANTIES OF MERCHANTABILITY, FITNESS FOR A PARTICULAR PURPOSE (AND THEIR EQUIVALENTS UNDER THE LAWS OF ANY JURISDICTION), OR INFRINGEMENT OF ANY PATENT, COPYRIGHT OR OTHER INTELLECTUAL PROPERTY RIGHT.

UNLESS EXPRESSLY APPROVED IN WRITING BY AN AUTHORIZED ST REPRESENTATIVE, ST PRODUCTS ARE NOT RECOMMENDED, AUTHORIZED OR WARRANTED FOR USE IN MILITARY, AIR CRAFT, SPACE, LIFE SAVING, OR LIFE SUSTAINING APPLICATIONS, NOR IN PRODUCTS OR SYSTEMS WHERE FAILURE OR MALFUNCTION MAY RESULT IN PERSONAL INJURY, DEATH, OR SEVERE PROPERTY OR ENVIRONMENTAL DAMAGE. ST PRODUCTS WHICH ARE NOT SPECIFIED AS "AUTOMOTIVE GRADE" MAY ONLY BE USED IN AUTOMOTIVE APPLICATIONS AT USER'S OWN RISK.

Resale of ST products with provisions different from the statements and/or technical features set forth in this document shall immediately void any warranty granted by ST for the ST product or service described herein and shall not create or extend in any manner whatsoever, any liability of ST.

ST and the ST logo are trademarks or registered trademarks of ST in various countries.

Information in this document supersedes and replaces all information previously supplied.

The ST logo is a registered trademark of STMicroelectronics. All other names are the property of their respective owners.

© 2008 STMicroelectronics - All rights reserved

STMicroelectronics group of companies

Australia - Belgium - Brazil - Canada - China - Czech Republic - Finland - France - Germany - Hong Kong - India - Israel - Italy - Japan - Malaysia - Malta - Morocco - Singapore - Spain - Sweden - Switzerland - United Kingdom - United States of America

www.st.com