

Z01 AND ACS BEHAVIOR COMPARISON TOWARDS FAST VOLTAGE TRANSIENTS

L.GONTHIER

Abstract:

Home appliances such as washing machines, refrigerators and dishwashers integrate a lot of low power loads such as valves, door lock systems, dispensers and drain pumps. These loads are powered by the mains in ON / OFF mode, and are mostly controlled by triacs or relays.

In most cases, the AC switching function now needs to be directly driven by a microcontroller unit (MCU) and it must withstand the A.C. line transients to make the system compliant with the new European Electromagnetic Compatibility (EMC) standards. STMicroelectronics ACSs™ (Alternative Current Switches) have been designed to meet these needs, as shown in this paper. Compared to triacs, they offer high robustness and dV/dt capability, while contributing to a substantial reduction of the overall electronic board size.

1. INTRODUCTION

The ASD™ concept, developed by STMicroelectronics, allows several devices such as diodes, thyristors, transistors and some passive components used to make a complete function, to be integrated on the same silicon die. This technology has been used to develop the new ACS structures.

ACS stands for Alternative Current Switch. It embeds an integrated driver, a clamping structure, and a bi-directional, thyristor-type switch (cf. Figure 1). The primary loads to be targeted by these new devices are high inductive loads like electromagnets, where the serial inductance can reach teens of Henry and the turn-off operation can thus cause many problems. The second paragraph explains how the clamping feature of ACSs enables them to directly drive any inductive load without any external clamping device, such as Metal Oxide Varistors, and how ACSs can also sustain overvoltages coming from the mains.

Silicon devices are not only subjected to surge voltages but also to fast transient voltages, as described in the EN61000-4-4 standard. Then, they must not only present clamping ability but also high immunity to high dV/dt rates. Results of experimental tests show the maximum levels held by ACSs and triacs, for different gate sensitivities.

Fig. 1: ACS structure synopses

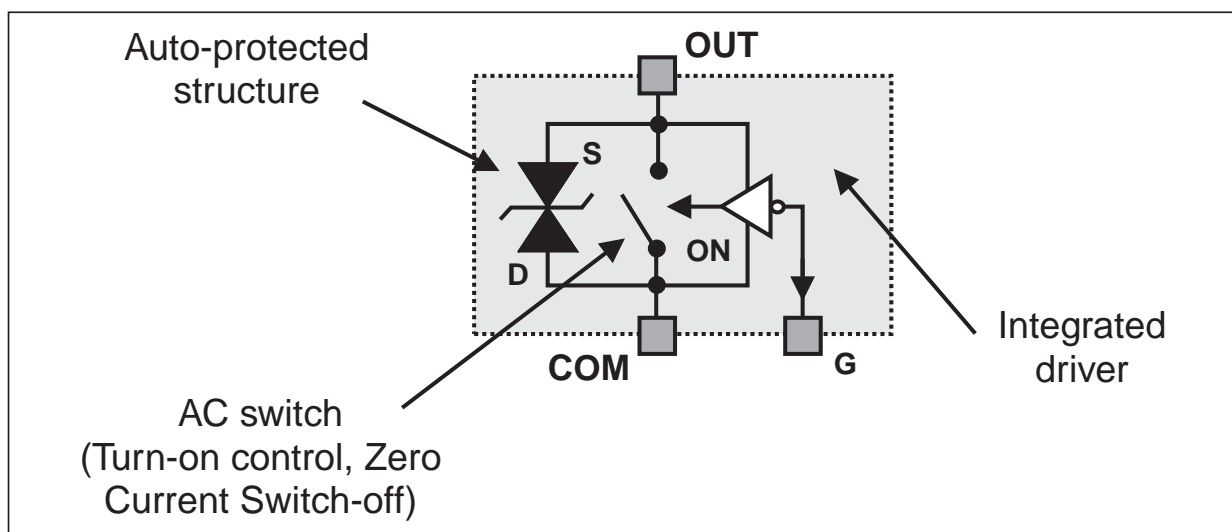

APPLICATION NOTE

2. THE ACS: AN OVERVOLTAGE PROTECTED AC DEVICE

2.1 Inductive loads switch-off

Valves and relays are both electromagnetic systems. In the case of AC high voltage operation, their windings show a high series resistance (a few $k\Omega$) and a high series inductance (tens of Henry). Hence, they absorb a low RMS current (typically, 10 to 50 mA). In this case, the current rate of decrease is low and an automatic switch turn-off may result, when its current becomes lower than the holding level [1].

There may be an over-voltage due to the fact that there is still some current through the inductive load. The inductive energy thus creates a back electromotive force. If this over-voltage is not clamped, it can reach the device breakdown level and damage it.

ACSs are self-protected against overvoltages. They can sustain their holding current in such an operating mode, as shown in Figure 2.

Fig. 2 : 230V 35mA RMS valve turn-off

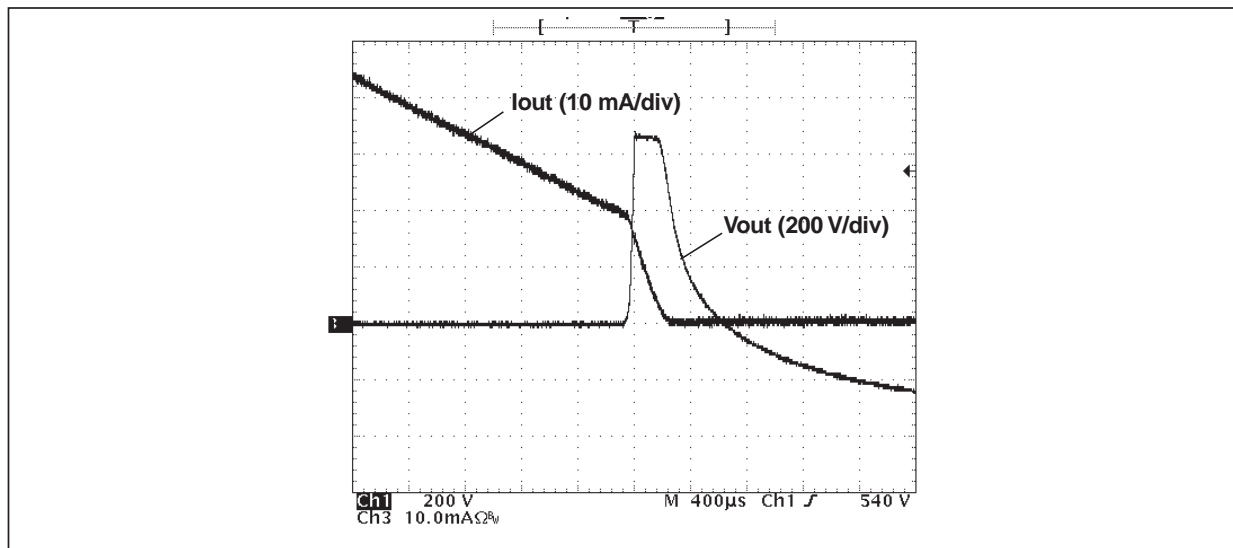

2.2 EN61000-4-5 standard

The EN61000-4-5 standard has been established to check whether systems can continue to work after there has been a voltage surge superimposed on the mains. A standard voltage waveform has been chosen which embodies typical over-voltages due to lightning or the disconnection of running inductive loads from the line.

As the Line to Neutral surge can appear at peak mains voltage, the overall amount of voltage can reach 2.4 kV. This will be higher than the breakdown level of the silicon devices used in appliances. Then, in order to prevent the destruction of components, designers use a varistor connected across silicon devices.

When a surge occurs and the ACS is OFF, the mains over-voltage is first clamped by the device. But an excessive energy surge can raise the ACS current above its breakover level. Then, the switch turns on in breakover mode [2] [3]. Such an event is particularly stressful on the semiconductor especially so if the current and its rate of increase are both high. The worst case occurs when ACSs are driving low resistance, non inductive loads (only 6 μ H serial parasitic inductance).

For example, Figures 3 and 4 have been recorded with a thermal active door lock system at a low temperature. The 2 kV surge is super-imposed on the 230 V - 50 Hz mains and synchronized with its peak value, as shown in Figure 3. Figure 4 shows the device turn-on in this mode. As the load was previously off, its resistance is cold and equals 150 Ohm. In this case, the current rises at a rate of 100 A/ μ s and reaches 15 A. Such transient surges would damage triacs, but not ACSs, as they are designed to turn-on in breakover mode. The varistor is then no longer needed in parallel across ACSs, unlike triacs. The difference between ACS and Triac + Varistor is that, with the ACS, the load is switched on during a half or one mains cycle. This can be accepted as such events happen a few times in the system's life.

Fig. 3: 2kV surge on the mains

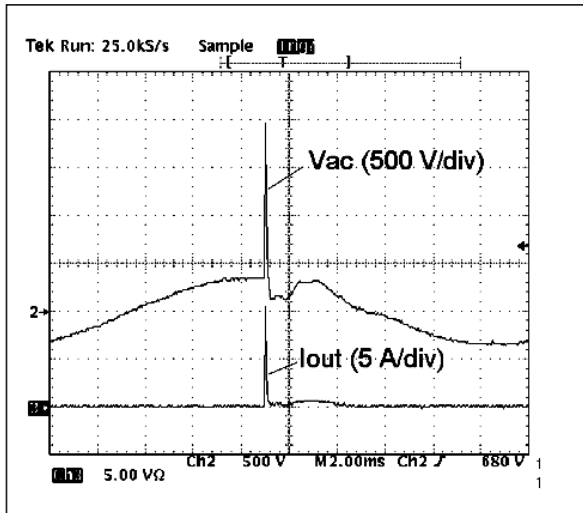
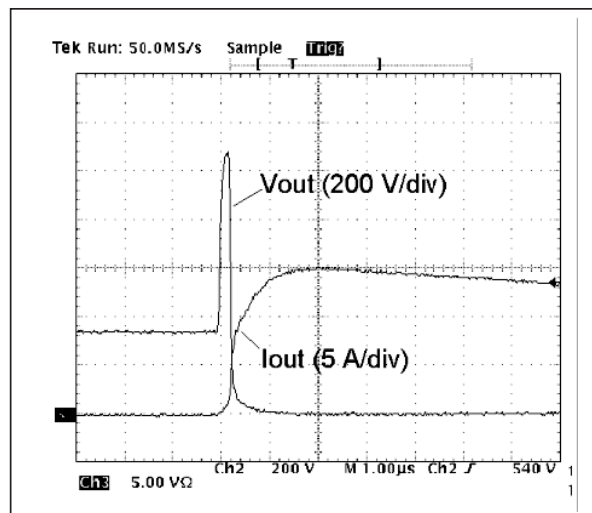

Fig. 4: ACS break-over



3. FAST TRANSIENTS IMMUNITY TESTS

3.1 Standard requirements and mains filter utility

EN61000-4-4 tests implement two different kinds of stress. One, called the “supply test”, consists of applying the bursts through 33 nF capacitors to the Line, Neutral, Ground or combinations of these terminals. The second EN61000-4-4 stressing mode is to apply the bursts through a typical 100 pF capacitor (achieved with an aluminum sheet), directly to the I/O ports of the system.

The I/O port test is in fact required for systems where there are control wires, as for computers (wires between the keyboard and the central unit). But appliance manufacturers perform similar tests to check if their products can withstand fast voltage transients.

For both cases, the system under test is placed 10 cm above the bursts generator reference plane. As the voltage waveforms increase and decrease respectively in 5 and 50 ns, the impedance of the parasitic capacitance between the system board and the plane is very low for such high dynamics waveforms. This results in the application of the major part of the burst directly across the mains supply plug of the system under test. The following figures show the Line to Neutral voltage measured during a 2 kV supply test. We see that the voltage reaches up to 1.41 kV when no filter is used at the mains input of the system. If a filter, such as that described in Figure 7, is added, the overvoltage, caused by the 2 kV burst falls to 584 V. This is below the breakdown voltage of most triacs used in 230 V appliances and of ACSs. Then, there is no risk of a spurious firing due to turn-on in breakover mode.

But Figure 6 also shows that, despite overvoltages being limited, high dV/dt rates are still present. Indeed, the 500 V overvoltage is reached in less than 10 ns. Silicon devices must therefore feature a very high dV/dt capability in order to avoid parasitic turns-on. The next paragraph summarizes some comparative analysis made on triacs and ACSs.

APPLICATION NOTE

Fig. 5: Line to Neutral voltage during 2kV burst without mains filter.

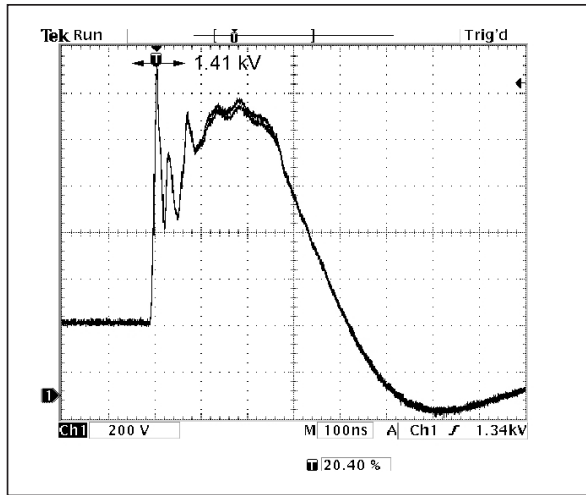
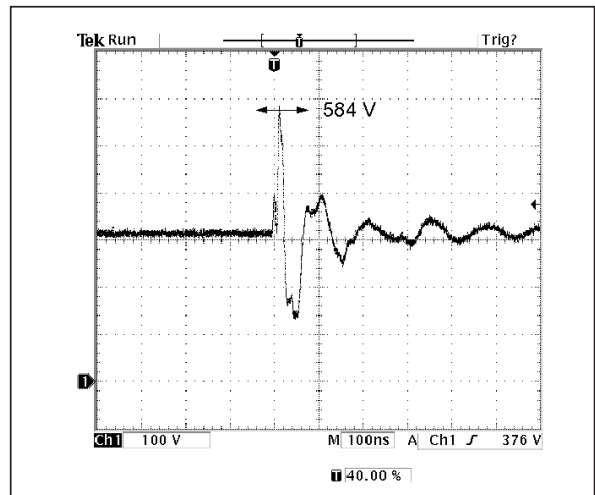

Fig. 6: Line to Neutral voltage during 2kV burst with mains filter.



3.2 ACS / TRIAC comparison

The tests are carried out in the following conditions (cf. Figure 7):

- Printed circuit board 10 cm above reference plane.
- A mains filter (as described in Figure 7) is connected to the mains plug.
- The board embeds four triacs (or ACSs).
- Each Triac-A2 (or ACS-OUT) terminal is linked to a 25 W light bulb (resistive loads are chosen in order not to reduce di/dt rates in case of firing).
- Each gate is connected to A1 or COM terminals respectively, for triac and ACS, through a 470 Ohm resistor (in order to be free of spurious firings coming from the microcontroller).
- No snubber circuits are added across the triacs or ACSs.
- Ambient temperature: 25 °C.
- The burst generator is programmed as required in the EN61000-4-4 standard (15 ms burst duration, 3 Hz burst frequency, 5 kHz spikes frequency, one second test duration).

Fig. 7: I/O test diagram

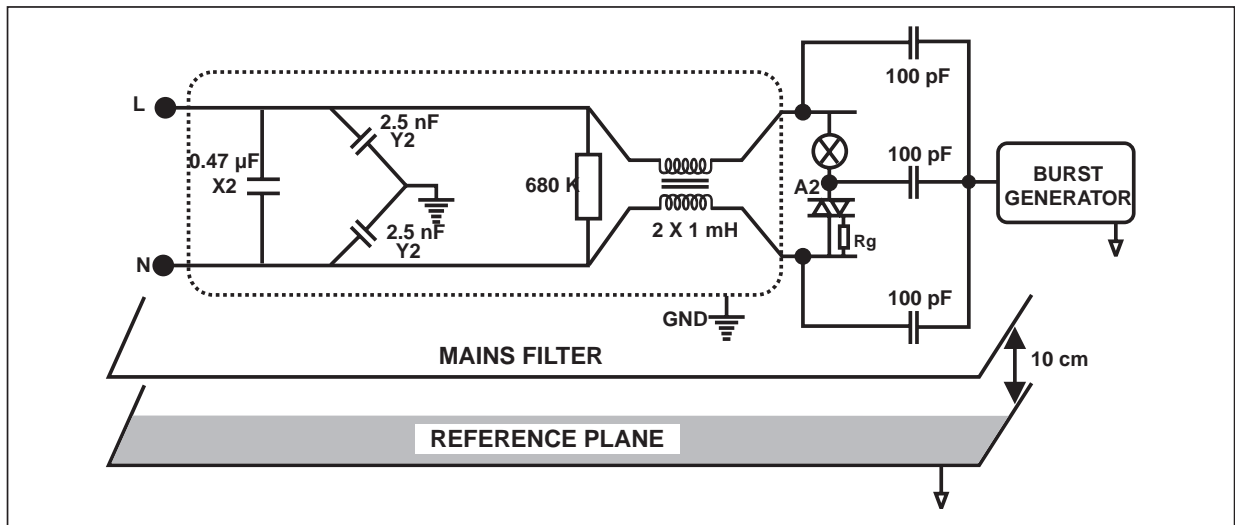

The high voltage output of the burst generator is connected:

- in the case of the “plug test”: to a 33 nF capacitor with its other terminal connected to L, N, Ground, or several of these terminals (as required in the EN61000-4-4 standard).
- in the case of the “I/O test”: to six 100 pF discrete capacitors with their other terminal connected to the four A2 (or OUT), L and N terminals (in order to simulate the coupling aluminum sheet).

A test is carried out for each coupling mode. The minimum burst level which causes a spurious firing, of one of the four devices, is measured. The histogram in Figure 8 gives the results of these experimental tests.

Sensitive triacs and ACSs with identical gate currents were compared. For a 5 mA maximum gate current, Z0107MA triacs and ACS102-5TA devices are used. For a 10 mA maximum gate current, Z0109MA triacs and ACS108-5SA / ACS402-5SB4 devices are used. All these components are in TO92 packages except the ACS402-5SB4 which is in DIL20 package. One can see that using one ACS array instead of several devices is an advantage in terms of noise immunity. Indeed, the board including four ACS108 in TO92 can sustain up to 3.7 kV and the other, including ACS402 in DIL20, can sustain up to 4 kV.

It can be noticed that the generator used can only delivers bursts up to 4.5 kV. Then, for some ACS108 and ACS402 devices, has not been reached the level above which they turn on.

The different capability of these devices depends on the dV/dt ability. The device can switch on due to excessive dV/dt rates. For example, Figure 9 shows, that a Z0109MA turns on after a 17 kV/μs rate, due to a 2 kV burst, coupled to the Line, in the “plug test” configuration. As, for the maximum junction temperature, 5 mA and 10 mA sensitivities ACSs can sustain up to 300 V/μs and 500 V/μs respectively, whereas Triacs of similar sensitivities only withstands 20 and 50 V/μs respectively, it is obvious that choosing ACSs will improve the burst immunity of the electronic board.

“I/O tests” have also been carried out. The difference between triacs and ACSs is more difficult to prove as most of the devices sustain bursts higher than the maximum capacity of the used generator (4.5 kV). Table 1 shows the results of these trials. In fact, the higher immunity of ACSs could be demonstrated by removing the mains filter. In this case, the board embedding ACS402-5SB4 will sustain bursts in the range of 4 kV, but for Z0109MA, the capability drops to around 3 kV.

Fig. 8: Minimum burst levels before turn-on for different tested devices

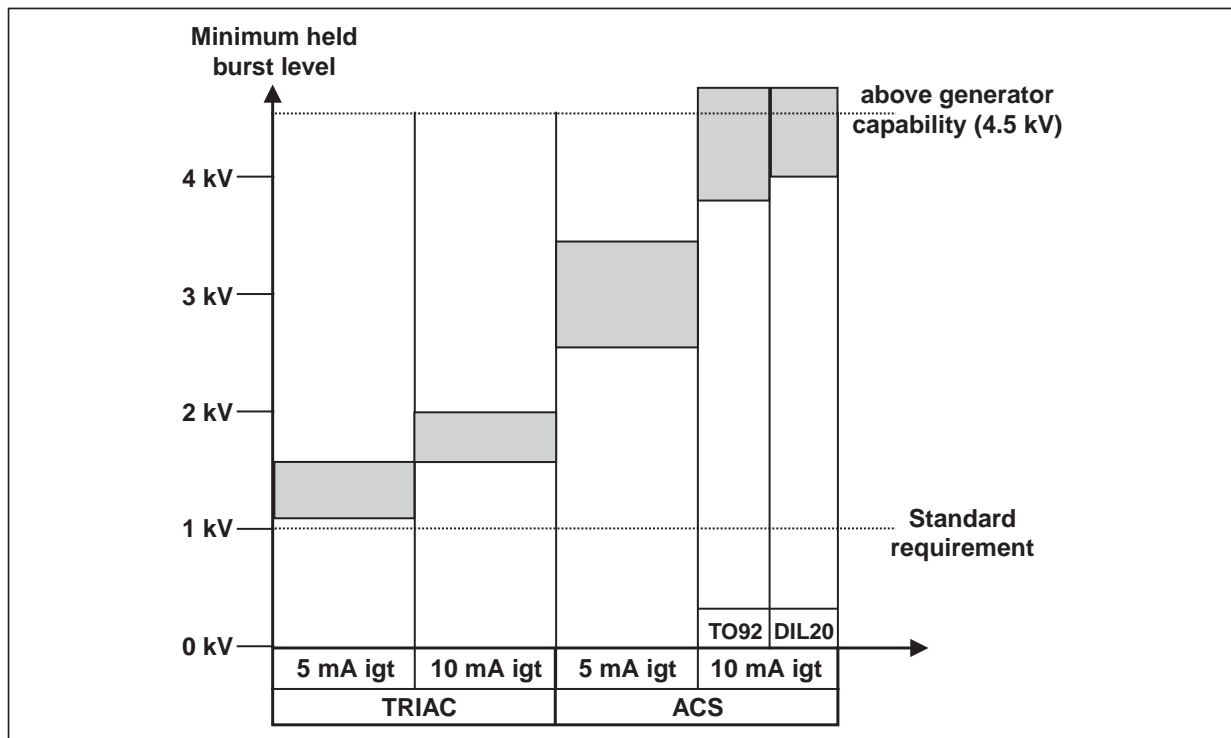

APPLICATION NOTE

Table 1: Minimum burst levels before devices turn-on for I/O tests

| DEVICE | Z0107MA | Z0109MA | ACS102-5TA | ACS108-5SA ACS402-5DB4 |
|-----------------------|---------|---------|------------|---------------------------|
| Min. level capability | 4kV | > 4.5kV | > 4.5kV | > 4.5kV |

Fig. 9: Spurious firing of a Z0109MA after a 2kV burst

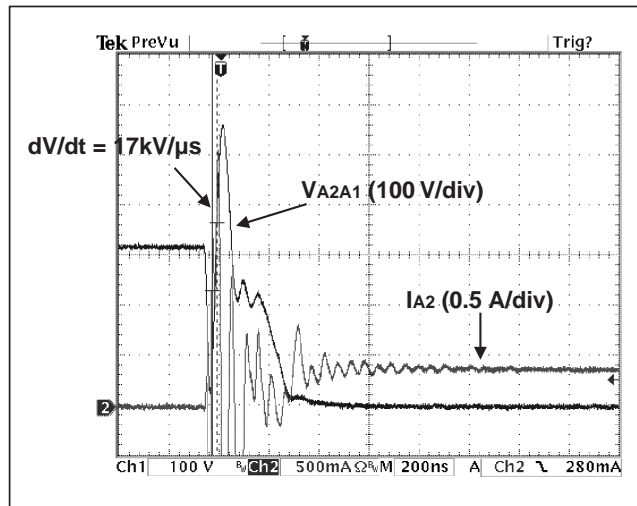

4. CONCLUSION

The EN61000-4-4 standard requires that for systems working on public power networks, the system must operate without any problem during burst voltages up to 1 kV. It has been shown that thanks to the mains filter, which is commonly added in washers in order to reduce the noise generated by universal motor brushes, triacs and ACSs of 5 mA sensitivity can pass the standard requirements. However, some manufacturers increase the burst level up to 2 kV. In this case, only ACSs will fulfill the requirement without additional components.

As for the triacs, they will turn on due to high dV/dt rates. An RC circuit must then be added to even out the dV/dt and designers must manage the following trade-off:

- 1- Reduce dV/dt rates: the snubber capacitance must be high and the snubber resistance must be low;
- 2- Reduce the dI/dt rate at turn-on: the snubber capacitance must be low and the snubber resistance must be high.

Along the fact that these snubbers and the varistors are no longer required with ACSs, using ACS reduces design time and increases electronic board reliability.

Information furnished is believed to be accurate and reliable. However, STMicroelectronics assumes no responsibility for the consequences of use of such information nor for any infringement of patents or other rights of third parties which may result from its use. No license is granted by implication or otherwise under any patent or patent rights of STMicroelectronics. Specifications mentioned in this publication are subject to change without notice. This publication supersedes and replaces all information previously supplied. STMicroelectronics products are not authorized for use as critical components in life support devices or systems without express written approval of STMicroelectronics.

The ST logo is a registered trademark of STMicroelectronics
 © 2001 STMicroelectronics - Printed in Italy - All rights reserved.
 STMicroelectronics GROUP OF COMPANIES
 Australia - Brazil - Canada - China - Finland - France - Germany
 Hong Kong - India - Israel - Italy - Japan - Malaysia - Malta - Morocco - Singapore
 Spain - Sweden - Switzerland - United Kingdom - United States.

<http://www.st.com>