

# Automation Control with Remote User Interface



Automation Controls with STM32MP1

STM32MP1 General Purpose MPU

STM32MP1 Rich Feature Set

STM32MP1 Applications

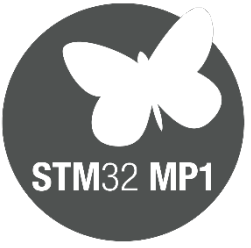

# Automation Controls with STM32MP1

Processing for HMI and Communication + Motor Control and Sensing

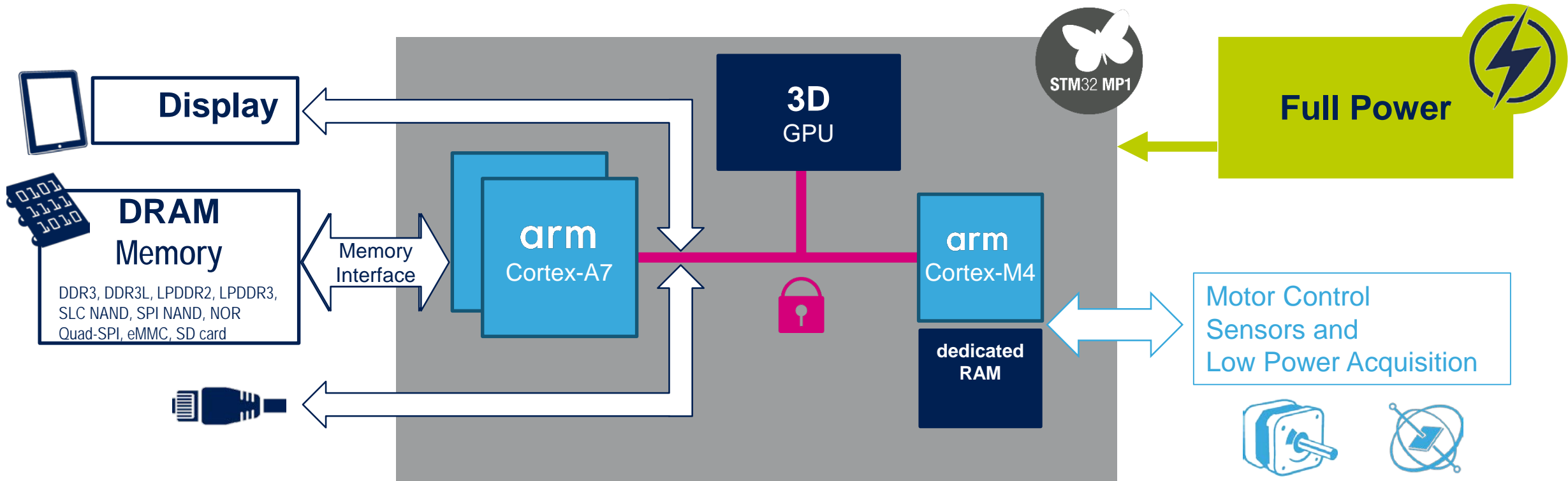

**Graphic and Communication processing**  
2470 DMIPS on dual Cortex-A7 + 3D GPU

**Motor Control, Sensors and Low Power Acquisition**  
260 DMIPS on Cortex-M4



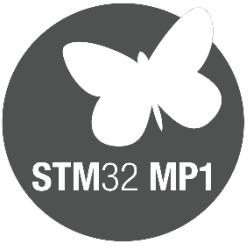

# STM32MP1: A General-Purpose MPU

Suitable for all Developer Types and Multiple Applications

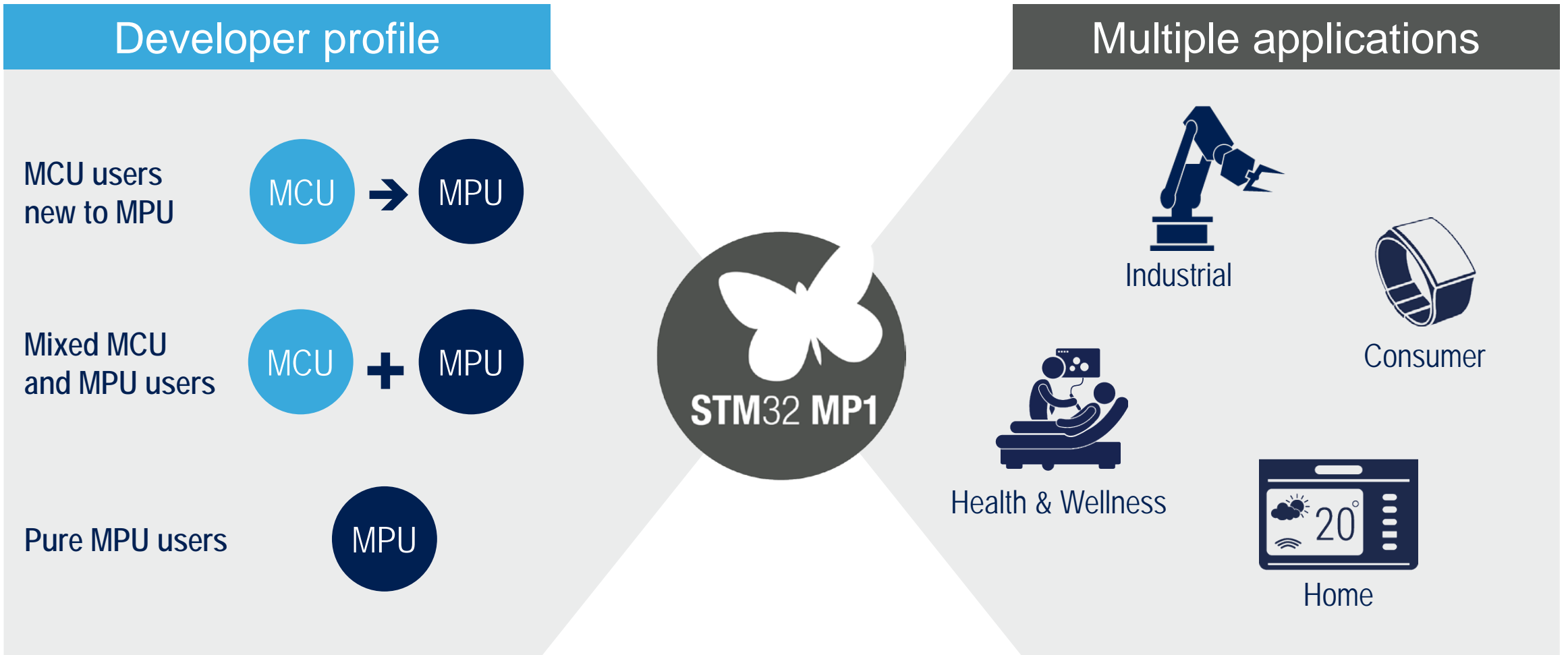

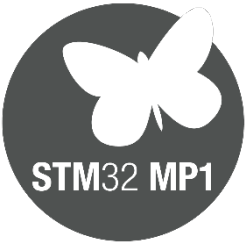

# STM32MP1 Rich Feature Set

Advanced & Flexible Architecture with 3D GPU

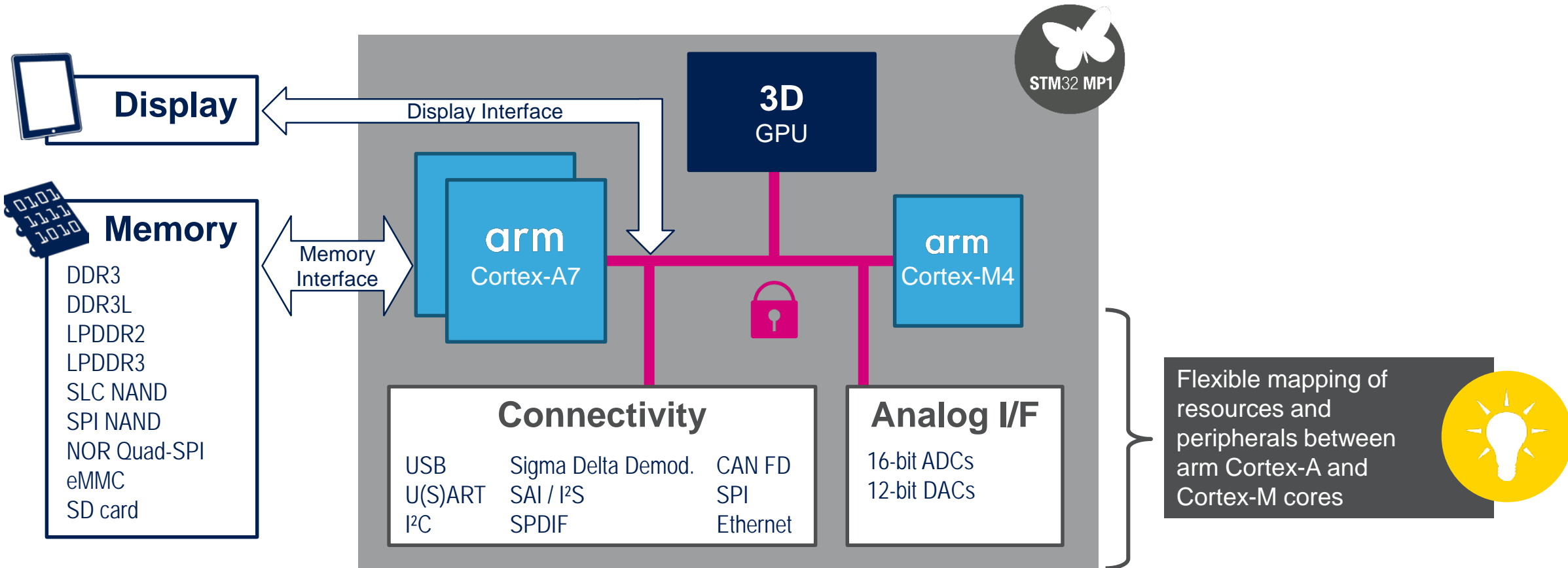

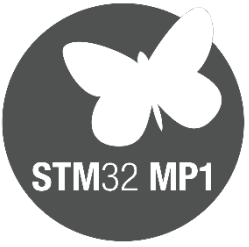

# STM32MP1 Target Applications

## Industrial

- Human Machine Interface
- Communication Gateway
- PLC
- Barcode Reader
- Building automation

## Consumer

- IoT Gateway
- Wearable
- Home Gateway
- Home Appliance
- Home Automation
- Home Audio
- Fitness Equipment
- Healthcare



And More...

