



life.augmented

Products and solutions for IO-Link technology



Contents

- 3 Why sensors and actuators' manufacturers are migrating to IO-Link?
- 4 IO-Link specifications
- 6 ST and IO-Link: a long story behind
- 7 L6360: the Master transceiver IC
- 9 L6362A: the Device transceiver IC
- 11 L6364: the Dual Channel IO-Link Device transceiver IC
- 13 Evaluation boards offering from ST
- 15 Ecosystem and application use case

Why sensors and actuators' manufacturers are migrating to IO-Link

IO-Link

Industrial sensors' and actuators' manufacturers are giving significant added value to the devices in the production line, by enhancing the measurement points with IO-Link capabilities.

IO-Link is the very first communication protocol answering the question of how to make sensors more intelligent: it was some tens of years, one first attempt has been with TEDS sensors (Transducer Electronics Data Sheet) in the 90's, where the big industrial players tried out to make sensors smarter. Measurement data, self-diagnostics, warnings, as well as device specifications are some inherent information that are perceived as important to carry out at any time from the sensor.

IO-Link is all of above, including reliability and features like hot plug and reverse polarity, given at a reasonable cost (standard interface and replacing of parallel wiring), considering also that industrial sensors are high value and high cost devices.

IO-Link technology finds place in all sensor based applications at factory level, where the end-point (a sensor or a valve, a motor starter or a RFID reader, for instance) is requested to be part of the lowest level network. Information is collected and given to higher level fieldbus, allowing the absorption of this basic p2p communication from the field into the smart industry environment.

Born in Europe, today IO-Link is covering a significant portion of the total offering for industrial sensors worldwide, with a consistent growth expected by the 2021 to triple the current amount of installations (source IHS Markit). This performance is also responsible of supporting Fieldbus installation nodes growth rate that is today close to Ethernet connected nodes.

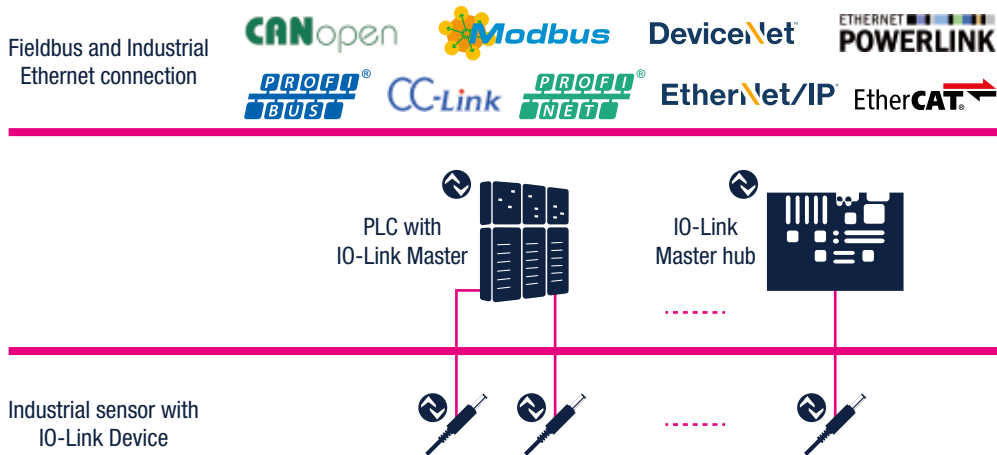

Fig. 1 – Typical factory automation architecture with IO-Link

IO-Link specifications

IO-Link protocol is centered on the industrial sensor, as it is based on IEC 61131-9, “Programmable controllers - part 9: Single-drop digital communication interface for small sensors and actuators (SDCI)”.

Typically, the architecture requires:

- a transducer for the sensor side, part of the sensor embodiment itself (called Device in the IO-Link terminology)
- a transducer as Master, responsible of interfacing to the upper layer of the industrial network (i.e. a PLC or a Fieldbus interface)
- the protocol defines also the wiring, with unshielded 3- or 5-wires standard cable (with M12, M8 or M5 standard industrial terminals).

A dashboard for settings and data analysis is the only requirement at software level.

The few hardware and software requirements listed above well represent the principle behind IO-Link: it is a simple p2p protocol (not a Fieldbus), with the purpose to collect information from the field (sensors and actuators) and interface to the higher levels.

With IO-Link, the industrial sensor has its own ID card. The IODD (IO Device Description) stores information regardless of the manufacturer (IODD file for any sensor has the same structure), such as:

- Device identification and parameters
- Process and diagnostics’ data
- Device data (including logo and manufacturer) with text description and illustration of the Device
- Communication properties

The IODDfinder is a non-proprietary database where all IODDs can be found (for any functionality either the V1.1 or the V1.0), it is available at <https://ioddfinder.io-link.com>.

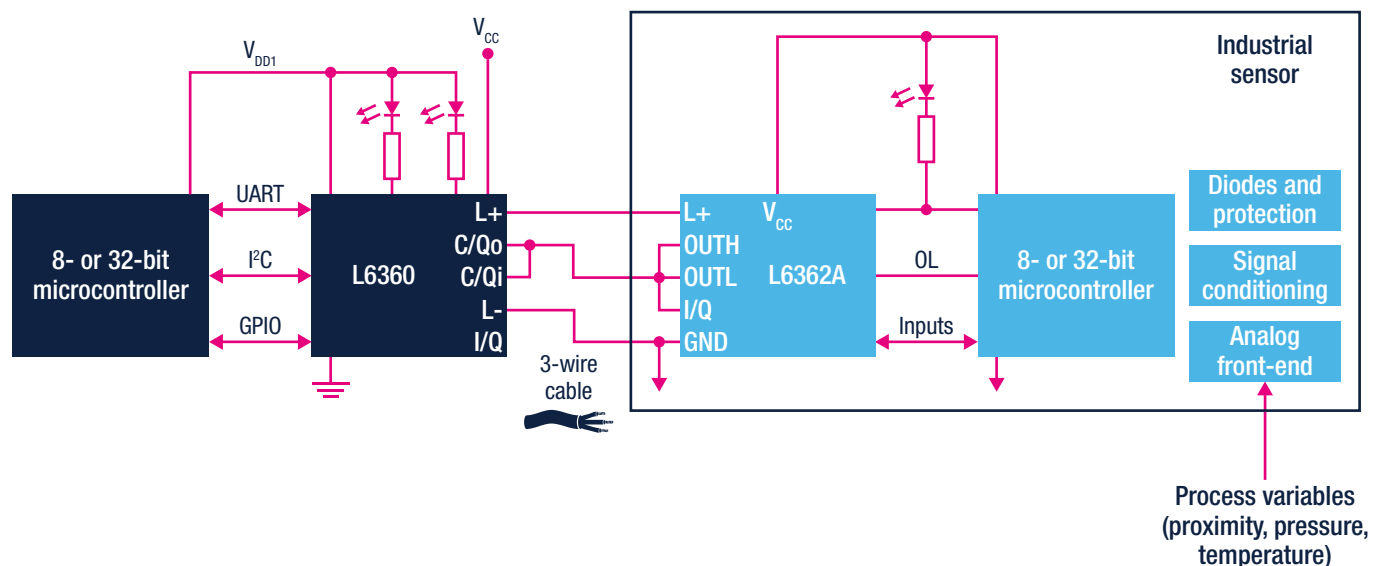
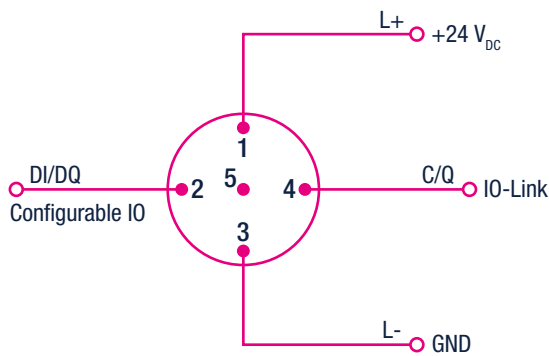

Fig. 2 – Typically a 3-wire cable (max 20 m) connects the Master (left side) to the industrial sensor

A table summarizing the main specifications in the version 1.1 is now introduced, while for a detailed study of the protocol, it is recommended to refer to the following website: <http://www.io-link.com>.

Feature	Value	Comment
Output enable mode	SIO or IO-Link	SIO mode is detected via short circuit
Communication modes	COM1, COM2, COM3	<ul style="list-style-type: none"> • COM1: 4.8 kBaud • COM2: 38.4 kBaud • COM3: 230.4 kBaud (introduced with V1.1)
Minimum cycle time	0.4 ms	Using COM3 mode, 2-byte process data and 1-byte service data
Data storage required	0.5 kByte	
Data type		<ul style="list-style-type: none"> • Process data: cyclic data exchange • Value status: cyclic data exchange • Device data: acyclic data exchange • Events: acyclic data exchange
Process data length	32 bytes	Max length, introduced with specification V1.1
Physical transfer layer	24 V	Pulse modulation
Port type	Class A IO-Link Master Port Class B IO-Link Master Port	See Figure 3 below
Cable length (max)	20 m	3-, 4- or 5-wire standard cable, with no special recommendations on screening

CLASS A IO-Link MASTER PORT



CLASS B IO-Link MASTER PORT

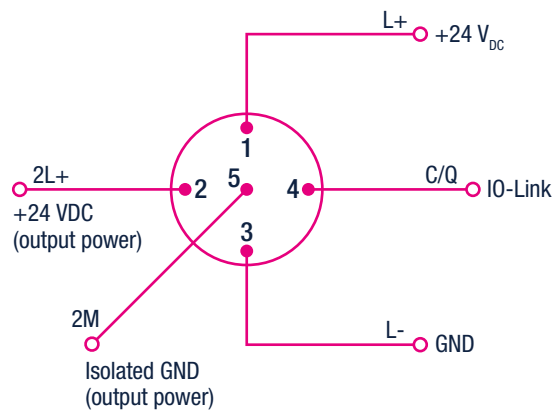

Fig. 3 – In both cases, the C/Q line is intended as configurable for IO-Link or SIO mode

ST and IO-Link: a long story behind



ST joined the IO-Link consortium since the beginning: at that time, most of the members were the biggest European industrial sensors makers and PLC manufacturers based in Germany.

In a few years, after understanding the importance of enabling IO-Link technology, many other worldwide players joined the consortium and the number is still growing, even with companies giving certification support, protocol stack development, cables and connectors and ICs manufacturers like ST. Some of the companies in the consortium are also capable of giving trainings and workshops.

Today, following the market evolution and the growing IO-Link adoption, the consortium has changed its organizational structure becoming a Technical Committee (TC6) within PI (PROFIBUS & PROFINET International) and is thus also represented in the Advisory Board, with dedicated Working Groups to develop specific areas like profiles or marketing.

Being one of the old members, ST offers both the Master and the Device ICs to implement the physical layer in the IO-Link communication, respectively named L6360 and L6362A. The two ICs are the result of a continuous refinement, based on the most stringent requirements from industrial sensors makers. A new Device IC named L6364 is ready and available on Q3 2020 on the open market.

L6360: the Master transceiver IC

The L6360 is a monolithic IO-Link Master transceiver compliant with PHY2 (3-wire), supporting COM1, COM2 and COM3 modes. The C/QO output stage is programmable: high-side, low-side or push-pull. Cut-off current and cut-off current delay time, combined with thermal shutdown and automatic restart, protect the device against overload and short-circuit. C/QO and L+ output stages are able to drive resistive, inductive and capacitive loads. Inductive loads up to 10 mJ can be driven. Supply voltage is monitored and low voltage conditions are detected.

The L6360 transfers (through the C/QO pin), the data received from a host microcontroller through the USART IN (C/QO pin), or to the USART OUT (C/QI pin). To enable full IC control, configuration and monitoring, the communication between the MCU and the L6360 is based on a fast mode 2-wire I2C. The L6360 has nine registers to manage the parameters and its status. Monitored fault conditions are: L+ line, over-temperature, C/Q overload, linear regulator under voltage, and parity check. Internal LED driver circuitries in open drain configuration, provide two programmable sequences to drive two LEDs.

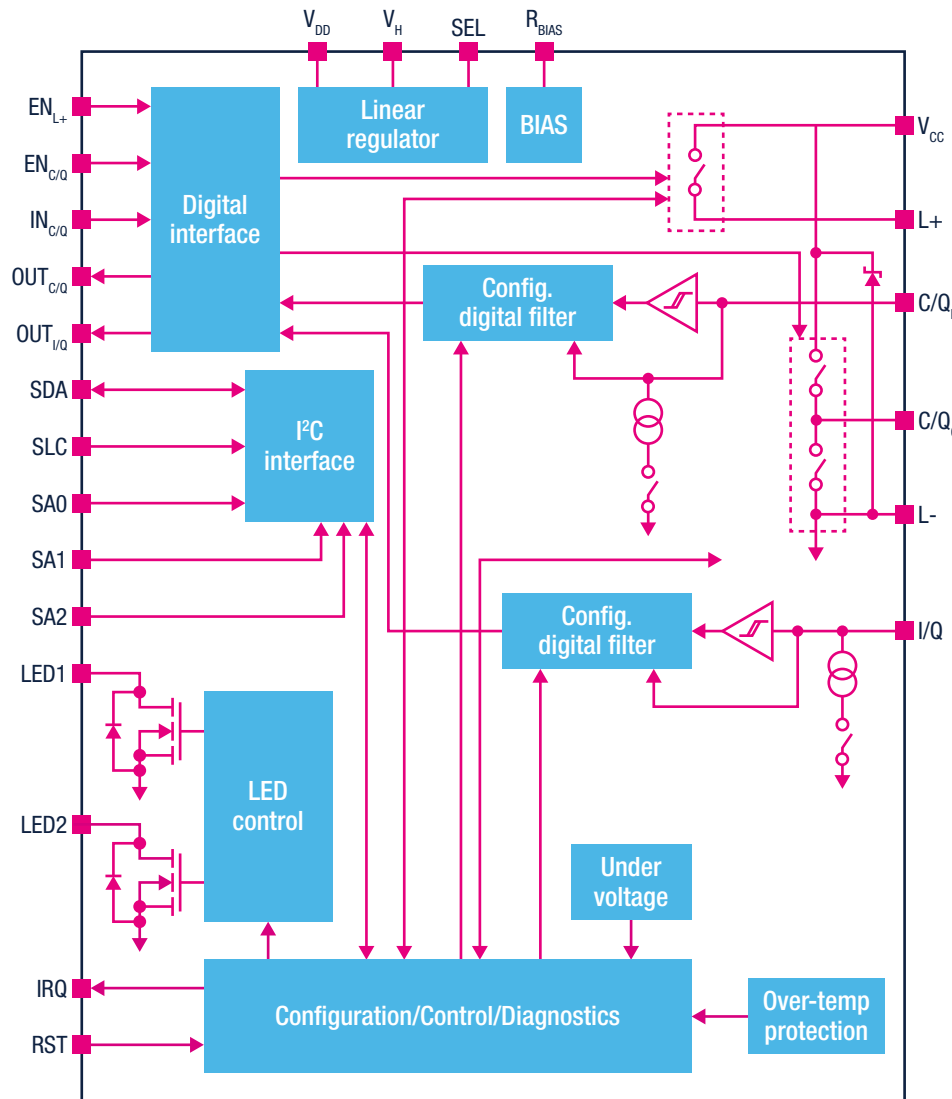

- L6360 IO-LINK COMMUNICATION MASTER TRANSCEIVER IC**
- Supply voltage range: 18 ÷ 32.5 V
 - Up to 500 mA L+ protected high-side driver
 - Supports COM1, COM2 and COM3 mode
 - Additional IEC61131-2 type-1 input
 - Programmable cut-off current, cut-off current delay time, and restart delay
 - Protections: short-circuit, overcurrent, overvoltage (> 36 V), overtemperature, ESD
 - Miniaturized: VFQFPN-26L (3.5 x 5 x 1 mm) package



Fig. 4 – L6360 block diagram (left) and main features listed on the right

The latest tool to evaluate the L6360 is the P-NUCLEO-IOM01M1. It is an STM32 Nucleo pack made up of two boards: the STEVAL-IOM001V1 (hosting the Master IC) and the NUCLEO-F446RE (with the STM32F446RE, ARM Cortex-M4 core with DSP and FPU, 512 Kbytes Flash, 180 MHz CPU, ART Accelerator, Dual QSPI).

With the P-NUCLEO-IOM01M1 you are capable to run the IO-Link stack V1.1 (property of TEConcept GmbH, with a license limited to 10k minutes, renewable upon request).



Fig. 5 – The P-NUCLEO-IOM01M1 kit is based on the STEVAL-IOM001V1 (reported in the picture) and the NUCLEO-F446RE

STEVAL-IOM001V1 KEY FEATURES

- IO-Link master PHY based on L6360
- Interrupt diagnostics pin
- I²C and UART interface
- SPI (slave) interface
- 65 mA selectable (3.3 or 5.0 V) linear regulator
- CQ (push-pull) and L+ (high side) switches
- IQ additional IEC61131-2 type 1 digital input
- L+ and CQ overload and overheating protections with non-dissipative cut-off function
- Additional high-side switch for L+ heavy loads (IPS161H)
- LEDs for status and diagnostics
- Ground and V_{CC} wire break protections
- EMC compliance with IEC61000-4-2, IEC61000-4-3, IEC61000-4-5
- Equipped with ST morpho connectors
- CE certified
- RoHS and China RoHS compliant

L6362A: the Device transceiver IC

The L6362A is an IO-Link and SIO (standard IO) mode transceiver IC compliant to PHY2 (3-wire connection) supporting COM1, COM2 and COM3 modes.

Low-side, high-side and push-pull output configurations are allowed with the L6362A which can drive any kind of load (resistive, capacitive or inductive). It is an ideal interface for industrial sensors running in the 24 V environment, to be connected to PLCs, industrial IO modules or IO-Link Master side.

The L6362A includes a rich set of protections, i.e. reverse polarity among V_{CC} , GND, OUTH, OUTL and I/Q pins, which is a key feature in the installation of industrial sensors. Other protections are output short-circuit, overvoltage and fast transient conditions (± 1 kV, 500 Ω and 18 μ F coupling). For more information, consult the datasheet.

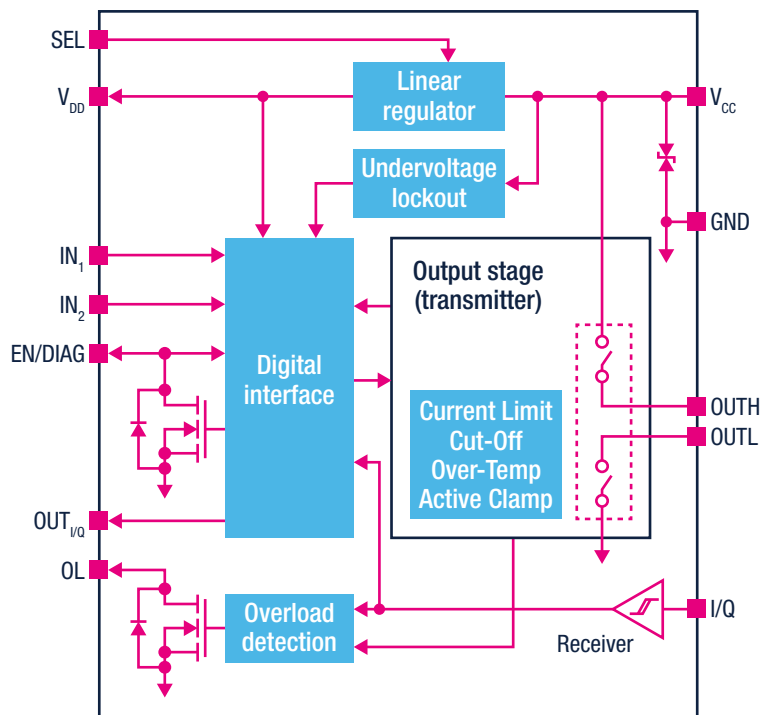

Fig. 6 – L6362A block diagram (left) and main features listed on the right

L6362A IO-LINK COMMUNICATION DEVICE TRANSCEIVER IC

- Supply voltage range: 7 ÷ 36 V
- Extremely efficient power stage:
 - $R_{DS(on)} = 0.8 \Omega / 1 \Omega$ (low- / high-side)
 - Output current up to 300 mA
 - Modes: high-side, low-side, push-pull
 - Able to drive L / C / R up to 500mJ / 30 μ F
- 5 V or 3.3 V, 10 mA selectable linear regulator
- Wake-up detection
- Protections: reverse polarity, over / under voltage, overload, over-temperature
- EMC robustness: Burst, surge, ESD
- -40 to 125 °C operating temperature
- Tiny DFN package (3 x 3 mm)



As well as commercial IO-Link Devices nodes, demonstration boards from ST have their own IODD file and as such find place in the IODDfinder, the centralized database for all IODD files.

Even in the case of the L6362A Device IC, a very good evaluation can be performed through an STM32 Nucleo pack available in the ST tools portfolio.

The P-NUCLEO-IOD01A1 is composed of:

- The STEVAL-IOD003V1, hosting the Device IC
- The NUCLEO-L073RZ with the STM32L073RZ (ultra-low-power ARM Cortex-M0+ MCU with 192 Kbytes Flash, 32 MHz CPU, USB, LCD)
- The X-NUCLEO-IKS01A2, a motion MEMS and environmental sensor expansion board for STM32 Nucleo

The STEVAL-IOD003V1 offers an IO-Link device PHY layer (L6362A) while the NUCLEO-L073RZ runs an IO-Link demo stack (developed by and property of TEConcept GmbH) compatible with V1.1 and firmware controlling the X-NUCLEO-IKS01A2 sensors.



Fig. 7 – The P-NUCLEO-IOD01A1 kit is made of NUCLEO-L073RZ, X-NUCLEO-IKS01A2 and the STEVAL-IOD003V1 (visible on top)

STEVAL-IOD003V1 KEY FEATURES

- IO-Link device PHY based on L6362A
- Operating voltage range 6.5 to 35 V
- Dedicated CQ overload pin (wake-up)
- Diagnostics pin (UVLO, over-temperature and cut-off)
- UART interface
- Linear regulators for independent supply from +24 V bus
- LEDs for status and diagnostics
- Overload and overheating protections with non-dissipative cut-off function
- Full reverse polarity on IO-Link interface pins
- EMC protections according to IO-Link V1.1 and IEC 60947-5-2
- Ground and V_{CC} wire break protections

L6364: the Dual Channel IO-Link Device transceiver IC

A new comer in our offering for IO-Link technology is the L6364 (available by September 2020); it provides a bridge between a microcontroller with a sensor or actuator function and a 24 V supply and signaling cable, specified to support IO-Link at COM2 and COM3 modes.

The L6364 has two input-output lines both protected against surge pulse and reverse polarity: one is the CQ line managing the IO-Link standard communication protocol, the other is DIO line available for standard IO communication.

The two lines are configurable to operate also in parallel for additional drive strength requirements (configurable up to 0.5 A). The IC offers two LDOs (3.3 V and 5 V) with 50 mA capability; the same LDOs can be directly supplied by the V+ rail or by the embedded DC-DC converter for applications with critical power dissipation requirements. Moreover, the IC offers an high level of flexibility (such as configurable thermal shut-down and UVLO thresholds) and extended diagnostics (such as, wake-up recognition and 7-bit calibrated temperature sensor register) reported by interrupt line to the microcontroller.

The sensor data transfer between microcontroller and L6364 can be selected using transparent mode (UART), single byte or multibyte (SPI) modes.

In normal operation the L6364 is configured by the microcontroller via the SPI interface at start-up. The L6364 starts operating in Single Input Output device driving the output lines as configured by the microcontroller. If the device is connected to an IO-Link master, then the master can initiate IO-Link communication by a wake-up request.

L6364 IO-LINK DUAL COMMUNICATION DEVICE TRANSCEIVER IC

- Supply voltage range: 5 ÷ 35 V
- Fully protected:
 - Internal reverse polarization diode (DOUT pin)
 - Full Zero Current Reverse Polarity protection
 - Configurable thermal shutdown levels
 - 7-bit, calibrated, temperature measurement
 - Configurable Under Voltage detection
 - Configurable short circuit current limit and reporting
 - Over Voltage to 35 V
- 5 V and 3.3 V, 50 mA linear regulators
- 50 mA DCDC regulator with configurable frequency and voltage (5 V-10.5 V)
- Dual outputs: high-side, low-side or push-pull (<10Ω)
- Integrated UART peripheral with M-sequence handling according to specification v1.1
- Internal data buffer for up to 15 bytes and continuous data transfer
- Zener limits for rapid inductive load switch off
- Two configurable current mode LED outputs
- Designed to meet application requirements:
 - ESD IEC 61000-4-2 protection to 4 kV
 - EMC surge protection 2 A/50 μs, (coupling 500 Ω)
 - -40 to 125 °C operating temperature
- Packages:
 - Tiny QFN-20L (4x4 mm)
 - Wafer Level Chip Scale Package CSP-19 (2.5x2.5 mm)

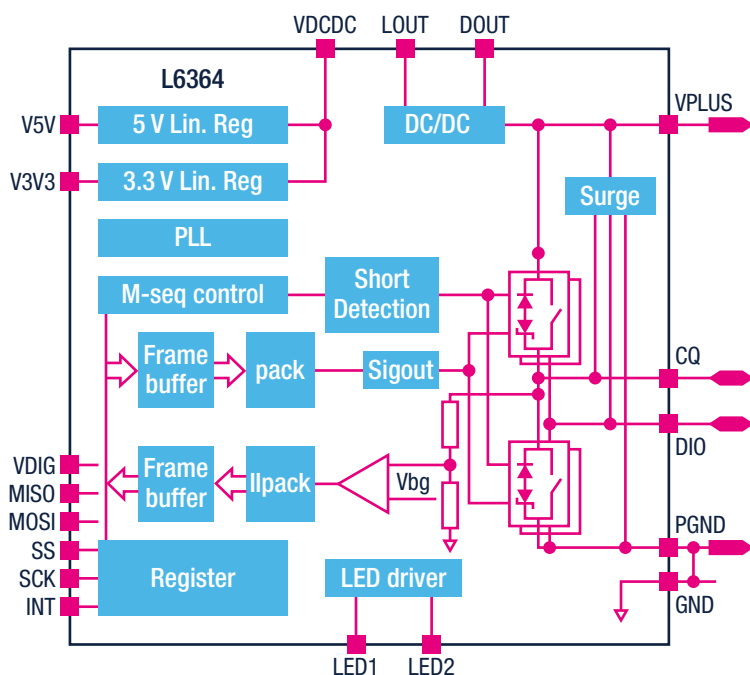

Fig.8 - L6364 IO-Link dual channel Device transceiver IC block diagram



As evaluation tool, we offer the new X-NUCLEO-IOD02A1 to help you to evaluate the L6364.

The expansion board provides an IO-Link device PHY layer based on the L6364, and can be coupled with one of the following STM32 Nucleo-64 development boards: NUCLEO-L053R8, NUCLEO-L073RZ or NUCLEO-G071RB.

The function pack P-NUCLEO-IOD02A1 made of the X-NUCLEO-IOD02A1, the X-NUCLEO-IKS02A1 (Motion MEMS and microphone MEMS expansion board for STM32 Nucleo) and one suitable Nucleo board, is a further support to make easier the development.

The X-NUCLEO-IOD02A1 will be available by September 2020, accordingly to L6364 availability.

A dual channel Device allows added value field controls: with the SIO channel dedicated to the simplest tasks (i.e. a node to be switched on) the diagnostics can simultaneously take place with IO-Link using the same cable.



Fig. 9 – X-NUCLEO-IOD02A1 expansion board based on L6364 for STM32 Nucleo

X-NUCLEO-IOD02A1 KEY FEATURES



- IO-Link device PHY based on L6364
- Operating voltage range 5 to 35 V
- SPI interface
- Status register (Short circuit, over-temperature and under-voltage)
- Overload and overheating protections
- Internal Linear regulators for independent supply from +24 V bus
- LEDs for status and diagnostics
- Full reverse polarity on IO-Link interface pins
- EMC protections according to IO-Link V1.1 and IEC 60947-5-2
- Ground and V_{CC} wire break protections

Evaluation boards offering from ST

A wide availability of IO-Link development boards are designed around the L6360 and the L6362A. Developers can select from basic, IC oriented evaluation boards to industrial ready reference designs and development kits.

All the tools in the table are including the IO-Link protocol stack v.1.1 provided by TEConcept GmbH (some limitations on protocol stack usability are about time duration and features).

Order code	Description	Picture (not in scale)
STEVAL-IDP004V2	<p>The STEVAL-IDP004V2 evaluation board embeds the STM32F205RB microcontroller and four separate L6360 IO-Link Master ICs. Communication with the ICs is implemented via I²C in master mode and is managed by the STM32F205RB: each L6360 shares the bus with the other ICs.</p> <p>The STEVAL-IDP004V2 is a multi-port master (or IO-Link master hub) based on serial asynchronous communication to support the IO-Link protocol (version 1.1 is embedded with limited features). Each node is equipped with an industrial M12 connector for connection with a single slave node using a cable (max length 20m). The wire is a normal 3-pole: one for the IO-Link bus, one for the L+ line (positive supply voltage pole) and one for the L- line (negative supply voltage pole).</p> <p>The STEVAL-IDP004V2 includes RS-485 bus, CAN bus and USB hardware interfaces. The layout is designed to meet the IEC61000-4-2/4/5.</p>	
STEVAL-IDP003V1	<p>The STEVAL-IDP003V1 kit includes the STEVAL-IDP003V1D evaluation board based on the L6362A IO-Link Device transceiver and the STM32L071CZ microcontroller, and the following sensor daughter boards: STEVAL-IDP003V1T (hosting the STTS751 temperature sensor), STEVAL-IDP003V1TV (hosting the MEMS sensor IIS2DH), STEVAL-IDP003V1A (hosting the MEMS sensor IIS328DQ) and STEVAL-IDP003V1P (hosting the proximity sensor VL6180X).</p> <p>The STEVAL-IDP003V1 kit has an industrial M12 connector (as required by the standard) for connection with any single master IC using a 20m (max length) cable. The wire is a normal 3-pole: one for IO-Link data, one for the L+ line (positive supply voltage pole) and one for the L- line (negative supply voltage pole).</p>	
P-NUCLEO-IOM01M1	<p>The P-NUCLEO-IOM01M1 is an STM32 Nucleo pack composed of the STEVAL-IOM001V1 and the NUCLEO-F446RE board.</p> <p>The STM32 Nucleo pack provides an affordable and easy-to-use solution to evaluate IO-Link applications, L6360 communication features and robustness, together with the STM32F446RET6 computation performances. The system (hosting up to four STEVAL-IOM001V1 to build a quad port IO-Link Master), can access the IO-Link physical layer and communicate with IO-Link Devices.</p> <p>You can evaluate the tool via the dedicated GUI (IO-Link Control Tool©, property of TEConcept GmbH) or use it as an IO-Link Master bridge accessible from the dedicated SPI interface: source code of demo project (Low-Level IO-Link Master Access, developed by TEConcept GmbH) and API specification are available for free.</p>	
P-NUCLEO-IOD01A1	<p>The P-NUCLEO-IOD01A1 is an STM32 Nucleo pack composed of the NUCLEO-L073RZ development board, the STEVAL-IOD003V1 evaluation board and the X-NUCLEO-IKS01A2 expansion board.</p> <p>The STM32 Nucleo pack provides an affordable and easy-to-use solution for the development of IO-Link and SIO applications, L6362A communication features and robustness, together with the STM32L073RZT6 computation performance.</p>	
STEVAL-IOM001V1	<p>The STEVAL-IOM001V1 is a single IO-Link master PHY layer (L6360). It is also part of the P-NUCLEO-IOM01M1 with the NUCLEO-F446RE board running an IO-Link stack compatible with v.1.1 (limited to 10k minutes, renewable without additional costs).</p>	

Order code	Description	Picture (not in scale)
STEVAL-IOD003V1	<p>The STEVAL-IOD003V1 is an IO-Link (PHY) device evaluation board based on L6362A with Arduino connectors for STM32 Nucleo. It is part of the P-NUCLEO-IOD01A1 with the NUCLEO-L073RZ which runs an IO-Link demo stack compatible with v.1.1 and firmware controlling the X-NUCLEO-IKS01A2 sensors.</p>	
STEVAL-BFA001V2B	<p>The STEVAL-BFA001V2B is an industrial reference design kit for condition monitoring (CM) and predictive maintenance (PdM). The kit consists of an industrial sensor STEVAL-IDP005V2, an STLINK-V3MINI programming and debugging tool, an adapter STEVAL-UKI001V2, a 0.050" 10-pin flat cable, a 4-pole cable mount connector plug and an M12 industrial connector with a 2 m cable. The firmware package STSW-BFA001V2 has been developed for the kit, including dedicated algorithms for time and frequency domain signal processing and analysis of the high bandwidth 3D digital accelerometer for vibration monitoring. IO-Link device stack v.1.1 (for evaluation purpose) is included in object library format with IO-Link Device Descriptor (IODD) for all measurements and with dedicated examples running with any master tool. It supports BLOB transfer for vibration and acoustic FFT data, event generator and parameter configuration. The package includes a GUI to demonstrate the IO-Link device features when connected to the STEVAL-IDP004V2.</p>	
X-NUCLEO-IOD02A1	<p>The X-NUCLEO-IOD02A1 is an IO-Link (PHY) device evaluation board based on L6364 with Arduino connectors for STM32 Nucleo. It is also part of P-NUCLEO-IOD02A1 which runs an IO-Link demo stack compatible with v.1.1 and firmware controlling the X-NUCLEO-IKS02A1 sensors. The X-NUCLEO-IOD02A1 will be available in September 2020.</p>	

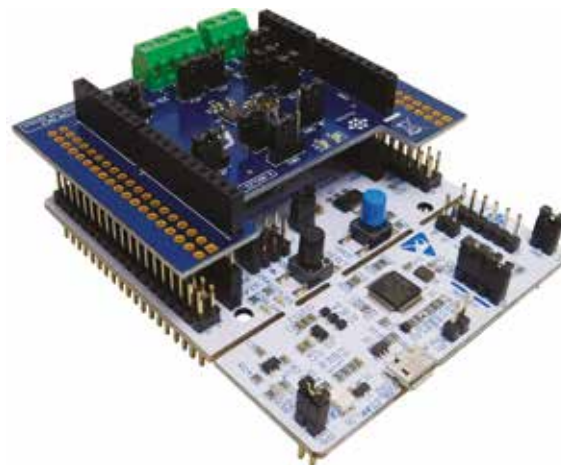

Fig. 10 – Example of ST solution where the X-NUCLEO-IOD02A1 expansion board (on top) is combined with the NUCLEO-G071RB.

Ecosystem and application use case

From ICs to the real applications: the **predictive maintenance** can be considered an application use case, where IO-Link protocol can be profitably used. The **STEVAL-IDP005V2** (part of the **STEVAL-BFA001V2B kit**), properly placed onto the motor chassis, is capable to collect and process (even locally) information on the motor health, through its embedded FFT libraries. The board features high performance ARM® Cortex®-M4 32-bit microcontroller (**STM32F469AI**), Ultra-wide bandwidth 3-axis digital accelerometer (**IIS3DWB**), a barometric pressure sensor (LPS22HB), a relative humidity and temperature sensor (HTS221), a digital microphone (IMP34DT05), EEPROM (M95M01-DF) for data Storage. The powerful FFT libraries are embedded for local processing but remote data processing is even possible thanks to the L6362A together with the M12 industrial connector.



Fig. 11 – Predictive maintenance needs smart sensors, edge processing and industrial protocols

Ecosystem is what ST offers besides the Master and the Device transceivers ICs which are the core of IO-Link communication. A rich evaluation board portfolio has been already introduced, but ecosystem means also development partners, and what these partners are doing independently to complement ST offering.



Historically, ST has referenced TEConcept GmbH (<https://www.teconcept.de>) as one of the most valued IO-Link protocol stack providers.

A three sides partnership has been signed among TEConcept, Arrow and ST: the result is the IOLM4P, a 4-port IO-Link Master chip solution based on the ultra-low power STM32L4, with integrated protocol stack, capable to control up to four IO-Link Devices.

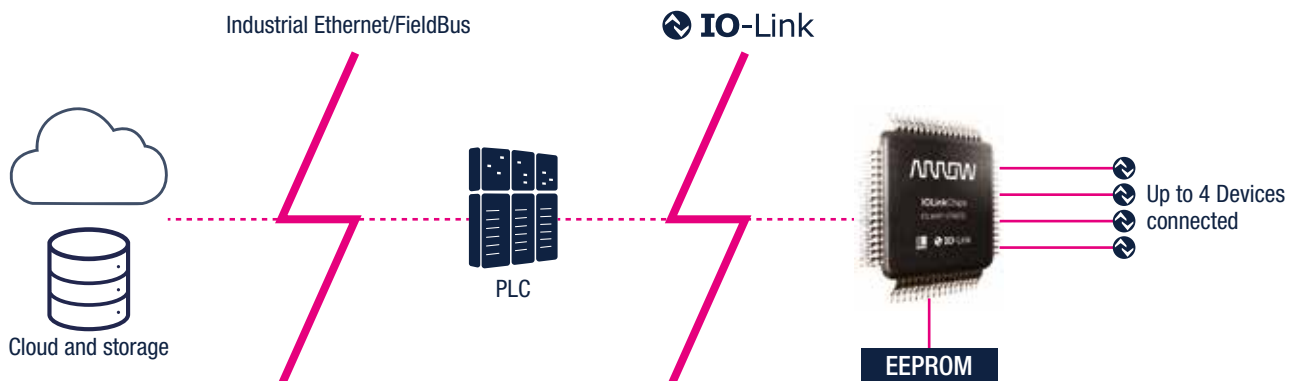

Fig. 12 – A simplified architecture where the IOLM4P from Arrow can be used

life.augmented



Order code: BRIOLINK0720

For more information on ST products and solutions, visit www.st.com

© STMicroelectronics - July 2020 - Printed in the United Kingdom - All rights reserved
ST and the ST logo are registered and/or unregistered trademarks of STMicroelectronics International NV or its affiliates in the EU and/or elsewhere. In particular, ST and the ST logo are Registered in the US Patent and Trademark Office. For additional information about ST trademarks, please refer to www.st.com/trademarks.
All other product or service names are the property of their respective owners.

