

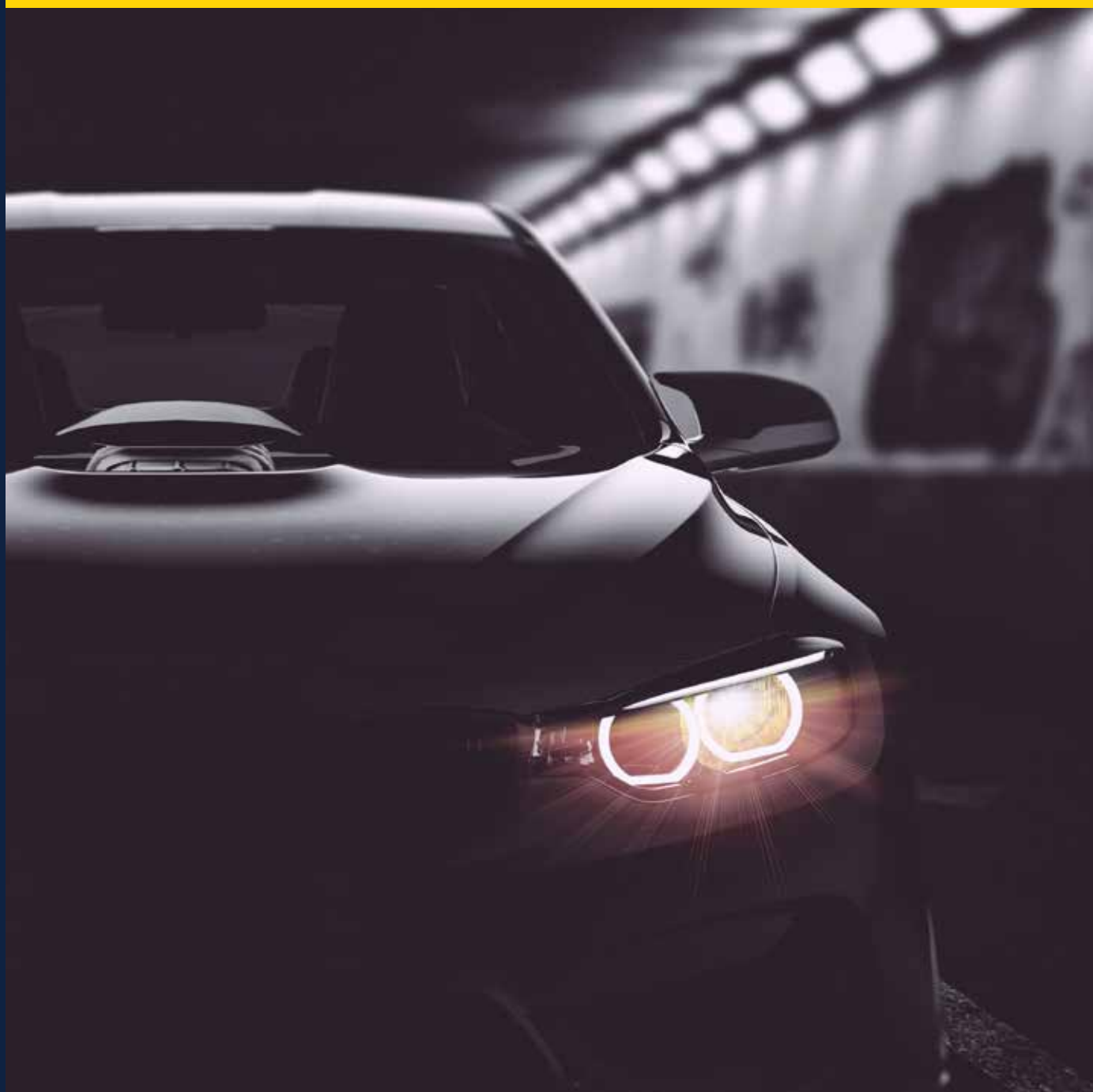

life.augmented

# How LED technology is bringing more meaning to automotive design



# Diving into the light cluster to understand LED lighting implementations

While today's vehicle owners are unlikely to have lights in their car that can be repaired without the support of a garage, cars at the beginning of the 20th century were lucky to have lights at all. Vehicle lighting was considered an optional extra back then, while the lights available were more focused on making the vehicle visible at night rather than lighting the way. Beautiful brass lamps, adapted from horse-drawn carriages and powered by oil, were the norm. Featuring four

glass sides, the glass protected the flame from the wind while in motion. Acetylene gas, generated by water dripping on carbide crystals, or under pressure in a cylinder-based system known as Prest-O-Lite, provided alternative approaches.

Over time, the electrically-powered incandescent light bulb was introduced, with their mirror-backed reflective housings providing an improved view of the road ahead during night-time jaunts. Even back then features such as adaptive headlights were developed. With the lamps directly linked to the steering system, they allowed drivers to peer around dark corners<sup>1</sup>.



## ADAPTING TO NEW TECHNOLOGIES AND TRENDS

In recent years, the incandescent bulb has slowly moved into retirement around the entire vehicle's lighting system. Halogen headlights have been giving way to HID Xenon solutions, while some manufacturers have also integrated LEDs and even lasers in their implementations. These changes have reduced power consumption while also improving driver visibility, making them feel safer on the road. Indicator lamps and the rear light clusters have also felt the impact, with LEDs fully replacing the older, filament-based light bulbs.

LEDs are mechanically more robust than incandescent lamps and, provided they are driven correctly, can provide significantly longer operational lifetimes. They also deliver the same level of illuminance at a lower power consumption. Thanks to their diminutive size, LEDs can also be integrated into mechanical designs that would have been inconceivable for their forebearers, giving automotive designers new opportunities to implement exciting styling to their vehicles. More recently, LEDs can be seen providing a more animated function, specifically in indicators. A string of LEDs may be driven so that the emitter driven appears to sweep across the length of the luminaire, an effect that has a certain charm.

Given that animation is already being utilised, there is discussion of whether lighting, especially rear-facing clusters, could be used for signalling information or warnings to drivers of other vehicles. With the advent of vehicle-to-vehicle (V2V) and vehicle-to-infrastructure (V2I) communication on the horizon, programmable lighting clusters could autonomously indicate worsening traffic conditions to following vehicles, allowing drivers to respond safely and in plenty of time.

## INTEGRATING AND CONTROLLING LEDS FOR AUTOMOTIVE APPLICATIONS

The introduction of LEDs as a light source has been a blessing for vehicle designers. Incandescent bulbs were a point light source and, with their large metal electrical bayonet or screw fitting and bulky glass globe, took up a lot of space. Thanks to their diminutive size and the fact that they can be positioned as required, multiple LEDs can be combined to create a surface light source. Whereas incandescent bulbs were expected to last around 1,200 hours, requiring replacement every two years or so, LEDs can operate for 50,000 hours or more. Thus, LED-based luminaires can be constructed in new ways that don't require access for replacing bulbs as previously.

LEDs are constant current devices and operate much like the diodes upon which they are based, but their forward voltage is dependent on the colour produced. This can be as high as 3.0 V for white, dropping to around 2.0 V for amber and red devices. Optimal and homogenous light generation requires that the current flowing through all the LEDs is maintained at a constant level, hence why automotive applications utilize constant current (CC) rather than constant voltage (CV) control. They will typically be configured in a string together with a DC/DC converter that ensures the desired current is carefully controlled, compensating for the variations in supply voltage that are caused by load dumps and start/stop systems.

The introduction of switching technology both at the front and rear of the vehicle naturally raises some issues, since the radio is typically at the front connected with the antenna at the rear. Electronic design engineers have to be mindful of the risks of electromagnetic interference (EMI) and ensure that standard precautions are undertaken. This ranges from board layout and switching frequency choice, to careful positioning of switching circuits, along with prudent use of ferrite beads in power supply lines.

Vehicle light sources are also considered to be safety relevant, so it is essential that some intelligence is also built in to detect any faults. Such faults need to be fed back to the driver of the vehicle. LEDs typically fail open-circuit, which is relatively simple to detect. However, as many as 20% of LED failures are short-circuit. Such a failure of a single LED in a string is challenging to detect and, most likely, the switching circuit will maintain delivery of its set constant current. This could lead to heating of the remaining LEDs as well as resulting in thermal runaway, since forward voltage drops and current draw rises in LEDs with an increase in temperature.

## DRIVING STRINGS OF LEDS

For the exterior front lighting domain, a string of LEDs can require up to 50 V or more and an average of 1.5 A in order that the control and setting of the output luminance fulfils the strict requirements of automotive OEMs. After a high-side switch stage (such as the M0-7E) that also provides diagnostics and protection to the lighting module, including load current limiting and reverse battery safeguard, the 12 V battery supply is fed to a boost stage. This steps the input voltage up to that required by the sum of the forward voltages of the LEDs in the string. From here, the boosted voltage is fed to a buck converter operating in continuous conduction mode, providing tight control of the current being fed to the string (Figure 1).

In order to provide feedback on the status of the lighting solution, and ensure that some functionality is maintained in the event of failure, it makes sense to evaluate an integrated solution that is dedicated to the task. This simplifies the integration, as well as the software implementation, for optimal interfacing with the vehicle's other systems.

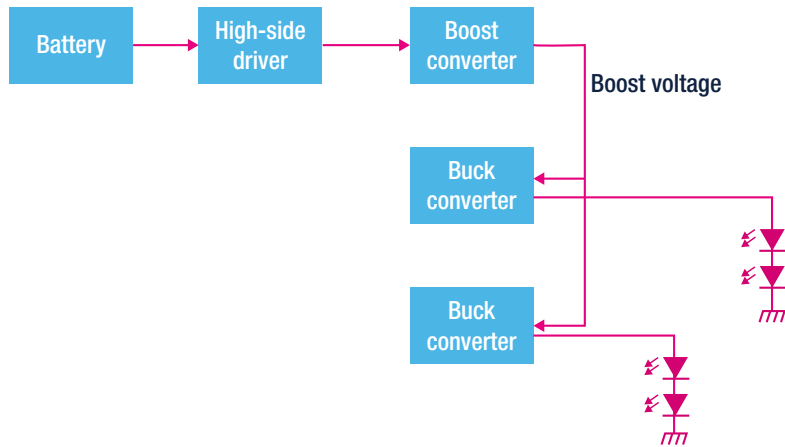

Figure 1: Basic construction of solution to drive strings of LEDs for automotive applications.

## AN AUTOMOTIVE QUALIFIED LED LIGHTING SOLUTION

A flexible LED driver that is AEC-Q100 qualified and suitable for all exterior LED light functions, such as indicators and daytime running lights through to fog lights and high/low beams, simplifies many of the challenges design engineers face. The L99LD21 is such a solution, integrating both a high efficiency boost controller that can supply the two in-built buck converters to drive two strings of LEDs (Figure 2).

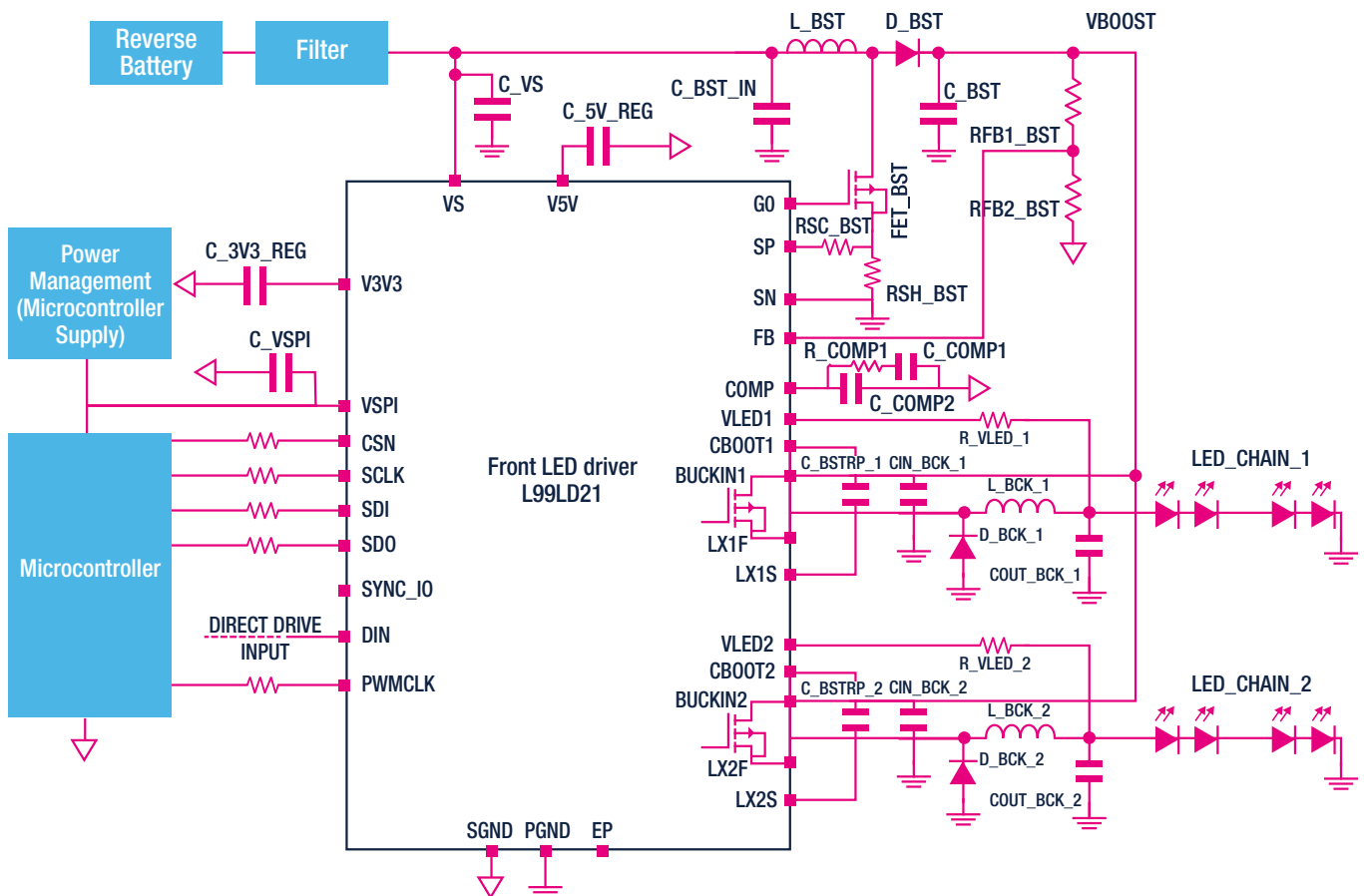

Figure 2: A single L99LD21, coupled with a microcontroller and reverse battery protection, driving two LED strings.

The boost controller can deliver a constant output voltage of up to 60 V and could even supply further LED strings controlled by their own buck converters. If needed, the boost controller stage of two L99LD21s can be combined to form a dual-phase, interleaved boost solution (Figure 3). Integrated circuitry ensures that a 180° phase-shift is maintained at all times. By sharing the current between the two phases, the efficiency of the overall implementation is increased. It also reduces input and output ripple, allowing for the use of smaller capacitors.



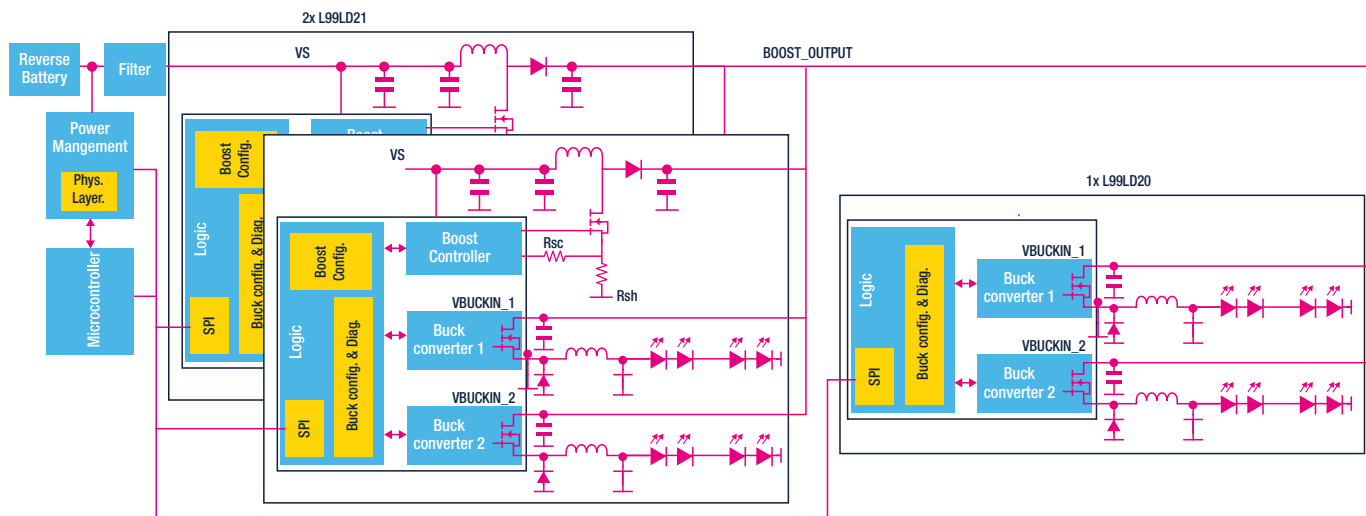

Figure 4: The boost controller from the L99LD21 can also be used to feed the buck converters of an L99LD20

The buck converters of both devices have built-in high-side n-channel switching MOSFETs, driven by gate drivers. Bootstrap capacitors of 100 nF are required to complement the integrated diode. In order to ensure that the bootstrap has enough time to recharge in every cycle, it is important to take into consideration that a minimum off-time is required. This limits the maximum ratio between the boost voltage provided and the forward voltage of the LED string. In combination with the on-time, the resulting operating frequencies can also creep into the AM radio band, another aspect that needs to be considered in the design stage. Thankfully the L99LDxy family can be configured to avoid AM radio band critical frequencies, allowing it to be tuned to the given inductance and  $V_{LED}$  of the application.

Full control and diagnostics are provided by the digital SPI interface of both devices. The operational state is defined by a state machine that transitions through a reset state after power on, putting the system into a known state. In the 'Active Mode' state, the outputs are controlled over the SPI interface by writing to the registers as defined in the datasheet.

The system state as well as a range of protection systems can also be evaluated too. In-built protection features range from temperature warning to over-temperature shutdown, buck open-load detection, and under voltage lockout. There is also an integrated watchdog counter. The buck  $t_{ON}$  and  $t_{OFF}$  timings are continuously monitored for incorrect operation. On the control side of the SPI, individual outputs can be turn on and off while a pulse-width modulated (PWM) register allows for dimming of strings by controlling the average current.

Should a failure occur that stops the system from entering Active Mode, the device automatically transitions into and resides in 'Limp Home' mode. In order to provide a minimum of functionality, the boost controller and buck converter 1 enter their operational state, while on/off control is implemented via a single digital input pin DIN. The SPI interface remains in limited operation, allowing the device to be switched into the Active Mode or Standby states if possible.

## INTEGRATION INTO THE E/E ARCHITECTURE

For the control and interfacing with the rest of the vehicle's E/E architecture, it is important to source an automotive qualified microcontroller that has been designed in compliance with ISO 26262. The SPC58 2B and B Line, 32-bit microcontrollers, are ideally dimensioned for this sort of application and were designed with support for ASIL-B applications in mind. It is worth noting that the SPC58 C Line offers further processing capabilities and memory size for enhanced needs. Depending on the complexity of the light cluster being developed, which may also include some servo-controlled mechanical beam shaping or steering, cooling control, or interfacing with PSI5 sensors, the SPC58 2B/4B offer a scalable range of device pin and memory options.

Two different kits are available to support the different application needs of design engineer, speeding-up the evaluation of these solutions.

For those interested in performing a full evaluation of L99LD21 and all its features, a very flexible GUI is available to control the system via a PC. The hardware kit SPC560B-DIS Discovery Board allows the L99LD21-ADIS to be plugged on top. The GUI can be downloaded from [www.st.com](http://www.st.com) under the name STSW-L99LD21ADIS.



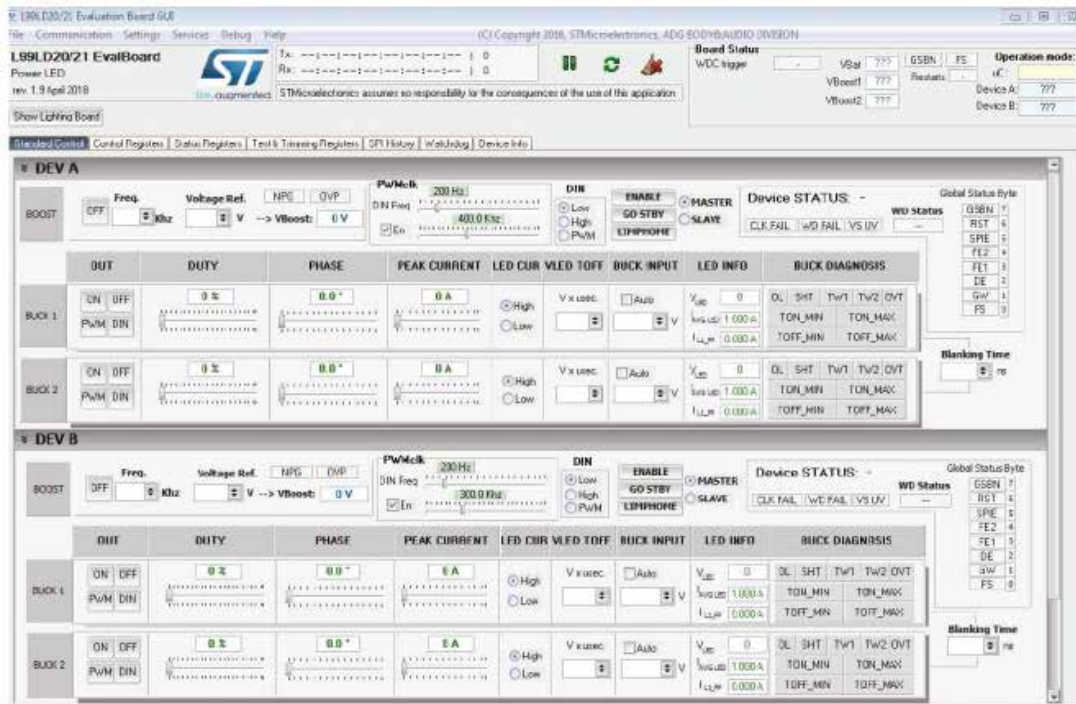

Figure 5: The GUI eases developers through the broad feature set of the L99LD2x LED drivers.

For those that want to quickly develop a working prototype and integrate the LED driving function into a larger system, the AutoDevKit™ toolset is more appropriate. The entire system can be constructed in a top-down approach allowing the developer to focus on the key functionality they wish to implement. For example, if the LED driver were to be paired with a SPC58 automotive microcontroller and a stepper motor drive, the hardware required would be:

- AEK-LED-21DISM1, containing two L99LD21 and four bucks for four LED strings
- AEK-MOT-SM81M1, stepper motor driver evaluation board based on the L99SM81V for automotive applications
- AEK-MCU-C1MLIT1 / AEK-MCU-C4MLIT1 or former SPC58 Chorus line discovery boards.



AEK-MCU-C4MLIT1



AEK-LED-21DISM1



AEK-MOT-SM81M1



EV-VN7050AS/  
EV-VN7040AS



AEK-CON-5SLOTS1



AEK-CON-AFLVIP2



AEK-MOT-SM81M1



**AutoDevKit**

KIT AEK-AFL001

Software: STSW-AFL001

All of these boards are fully supported and managed within the SPC5 Studio integrated IDE with AutoDevKit™. Once the above boards have been selected in the tool, the pin allocation and peripheral configuration is carried out automatically and a guide for connections is presented through the Board View Editor. The user only needs to write the main() function, calling high-level APIs to control each board that masks all the hardware complexity. Once the code has been generated and compiled, it is downloaded into the microcontroller through the UDE tool from PLS (free starter licence available).

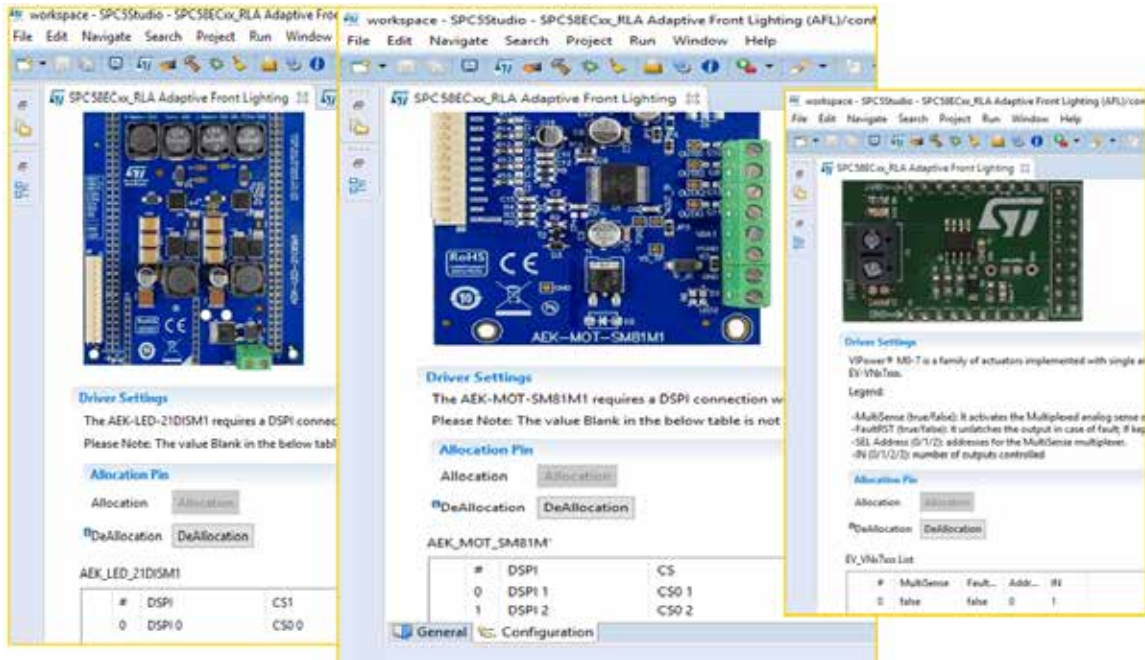

AutoDevKit™ component selection

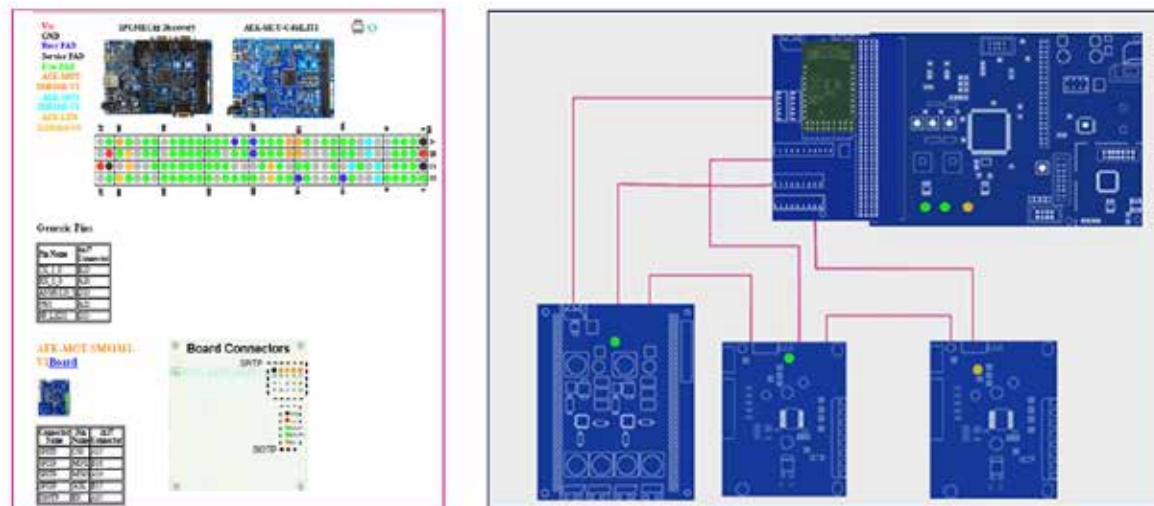

AutoDevKit™ supported hardware connection



- AFIDemo
- SPC58ECxx\_RLA Adaptive Front Lighting (AFL)
- SPC58ECxx\_RLA Adaptive Front Lighting
  - SPC58ECxx Platform Component RLA
  - AutoDevKit Init Package Component
  - SPC5 AEK\_RELEASE\_NOTE Component R
  - SPC58ECxx Init Package Component RLA
  - SPC58ECxx Low Level Drivers Componen
  - SPC5 AEK\_LED\_21DISM1 Component RLA
  - SPC5 AEK\_MOT\_SM81M1 Component RL
  - SPC5 EV\_VNx7xxx Component RLA
  - [Dep] Board wizard component
  - [Dep] SPC58ECxx Board Initialization Con
  - [Dep] SPC58ECxx Clock Component RLA
  - [Dep] SPC58ECxx IRQ Component RLA
  - [Dep] SPC58ECxx OSAL Component RLA
- components
- source
- build

### SPC58ECxx Low Level Drivers Component RLA

SPC58ECxx Low Level Drivers options and settings.

Copyright (C) STMicroelectronics. All rights reserved.

#### Enabled Drivers

Select which drivers are needed in your application. Disabled drivers take no system resour

DMA <input checked="" type="checkbox"/>	SARADC <input checked="" type="checkbox"/>	CAN <input checked="" type="checkbox"/>
Serial <input type="checkbox"/>	PIT <input checked="" type="checkbox"/>	STM <input type="checkbox"/>
SPI <input checked="" type="checkbox"/>	I2C <input type="checkbox"/>	SWT <input type="checkbox"/>
CRC <input type="checkbox"/>	FCCU <input type="checkbox"/>	PWM <input type="checkbox"/>
ICU <input type="checkbox"/>	WKPU <input checked="" type="checkbox"/>	LIN <input type="checkbox"/>
I2S <input type="checkbox"/>	SEMA4 <input type="checkbox"/>	RTC <input type="checkbox"/>
BCTU <input type="checkbox"/>	CMPU <input type="checkbox"/>	

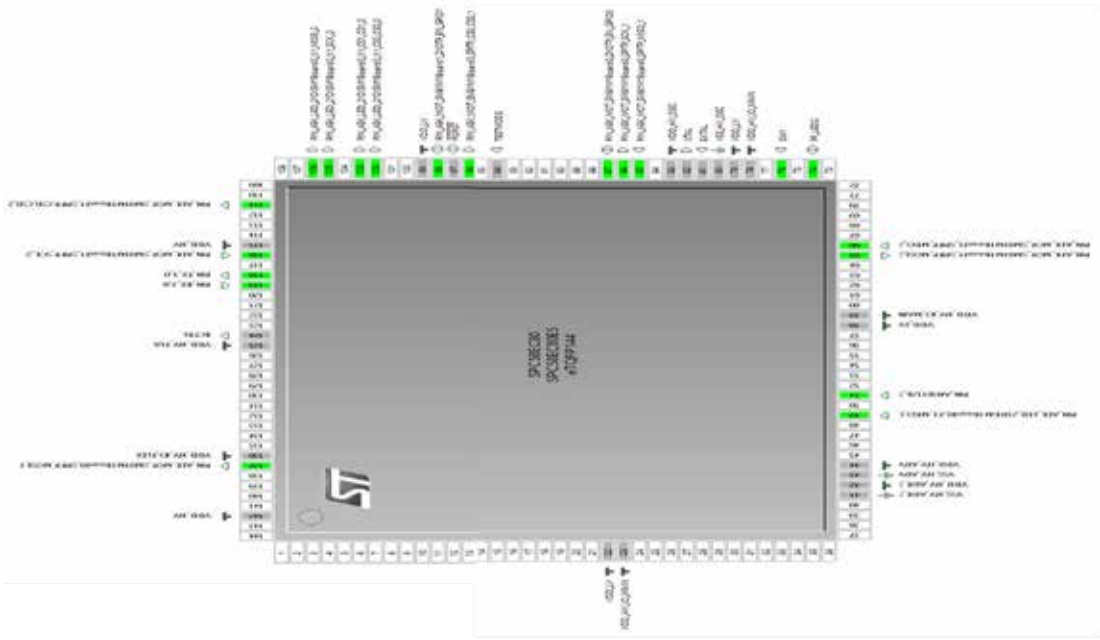

AutoDevKit™ supported MCU hardware configuration and pin allocation

There is also a pre-assembled kit including LED driver, two stepper motors, and a cooling fan for a full system demonstration (AEKD-AFLPANEL1, AEKD-AFLLIGHT1).



**AEKD-AFLPANEL1**



**AEKD-AFLLIGHT1**

The complete Adaptive Front Lighting Kit available to buy



Automobile designers are unlikely mourning the demise of the incandescent light bulb as the LED, thanks to its small dimensions, opens up a whole host of opportunities for both front and rear light clusters that have seen little change for decades. However, for electronics engineers, there are a whole host of challenges that arise with this move. While blinking an LED is probably the first thing most embedded development engineers have done, controlling the luminance of a string of LEDs to the exacting standards demanded by automotive OEMs is something completely different. Devices such as the L99LD21 and L99LD20 simplify much of this complexity, providing not only the required control but also the diagnostic features demanded. And, when used together with proven SPC58 automotive microcontroller technology, software development and integration into the vehicle's E/E architecture is made significantly easier.

1. <http://knowhow.napaonline.com/fire-automotive-lighting-history/>

For more information on ST products and solutions, visit [www.st.com](http://www.st.com)

© STMicroelectronics - May 2020 - Printed in United Kingdom - All rights reserved  
The STMicroelectronics corporate logo is a registered trademark of the STMicroelectronics group of companies  
All other names are the property of their respective owners



life.augmented