



**Buck high-brightness LED driver based on the ST1S10
step-down DC-DC converter voltage regulator**

Introduction

High-brightness LEDs are becoming a prominent source of light because of their long life, ruggedness, design flexibility, small size and energy efficiency. LEDs are now available in higher and higher wattages per package (1 W, 3 W and 5 W) with currents up to 1.5 A. At these current levels, the traditional means of limiting current with a resistor is not sufficiently accurate nor efficient. Today, single-dice, white HBLEDs capable of delivering up to 90 lm/W of light are available. A typical 1 W white LED delivers an optical efficiency of 30 lm/W, whereas a typical 60 W light bulb delivers 15 lm/W.

It is known that the brightness of an LED is proportional to the forward current, so the best way to supply LEDs is to control the forward current to get good matching of the output light. LED manufacturers specify the characteristics (such as lumens, beam pattern) of their devices at a specified forward current (I_F), not at a specific forward voltage (VF).

This application note describes how to implement a constant current control to drive high-brightness LEDs by a step-down DC-DC converter voltage regulator. A switching regulator is the best choice for driving HBLEDs when high efficiency and low power dissipation are required.

The circuit uses the ST1S10 high-efficiency buck converter configured to drive a single HBLED in constant current mode.

The ST1S10 is a step-down monolithic power switching regulator which needs few external passive components and it is capable of delivering 3 A. An internal oscillator fixes the switching oscillation at 900 kHz, and it is possible to synchronize the switching frequency with an external clock from 400 kHz to 1.2 MHz.

This application note includes a schematic diagram, bill of material (BOM), and test data.

Contents

- 1 Background 4**
- 2 Buck topology switching power supply 6**
- 3 Design example 10**
 - 3.1 Design parameters 10
 - 3.2 Power stage selection 10
 - 3.3 Current sense 11
 - 3.4 Inductor selection 11
 - 3.5 Output capacitor selection 12
 - 3.6 Input capacitor selection 12
- 4 Description of the board 13**
 - 4.1 Input/output connection 13
- 5 Schematic and bill of material (1 A LED current) 14**
- 6 Board layout 15**
- 7 Typical application waveforms 17**
 - 7.1 Startup 17
 - 7.2 Switching waveform 17
 - 7.3 PWM dimming using the enable function 18
- 8 Revision history 19**

List of figures

Figure 1.	Constant voltage control	4
Figure 2.	Constant current control	5
Figure 3.	Constant current control with V_{SENSE} amplification	5
Figure 4.	Buck topology	6
Figure 5.	Buck converter circuit while the switch is in position 1	6
Figure 6.	Inductor current waveform	7
Figure 7.	Buck converter circuit while the switch is in position 2	7
Figure 8.	Output impedance	9
Figure 9.	Schematic - LED current 1 A	14
Figure 10.	Assembly layer	15
Figure 11.	Top layer	16
Figure 12.	Bottom layer	16
Figure 13.	Startup	17
Figure 14.	Steady-state operation	17
Figure 15.	PWM dimming	18

1 Background

When designing a power supply for a white high-brightness LED, the main requirements are efficiency, size and cost of the complete solution.

A standard buck converter is the best choice for providing a constant current because only the buck converter among the switching topologies has an average inductor current that is equal to the average load current. For this reason, the conversion of a constant voltage into constant current is much easier.

LEDs are current-driven devices whose brightness is proportional to their forward current. Forward current can be controlled in two ways: voltage mode and current mode. The first method uses the LED V-I curve to determine what voltage has to be applied to the LED in order to generate the desired forward current. This is typically accomplished by applying a voltage source and using a ballast resistor as shown in [Figure 1](#). This method has two serious drawbacks. The first is that every change in LED forward voltage creates a change in LED current. The second problem is the power lost across the ballast resistor which reduces the efficiency.

Figure 1. Constant voltage control

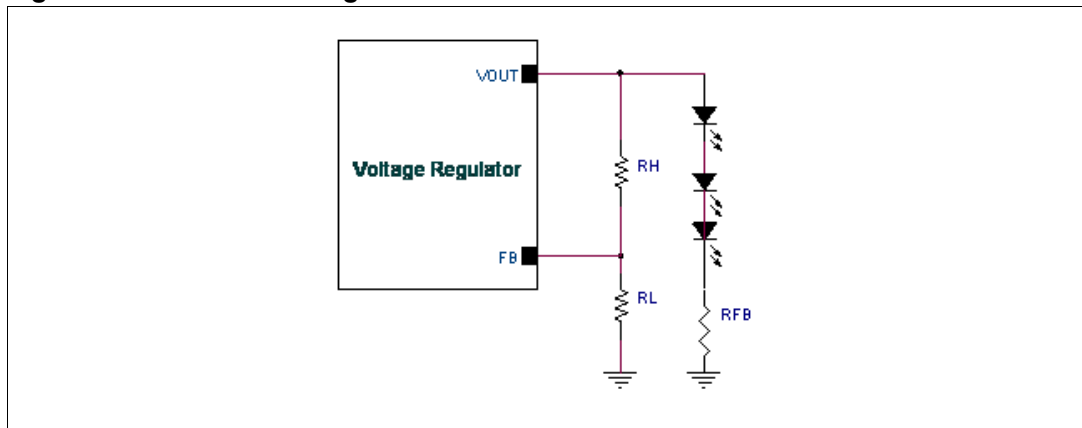

Equation 1

$$V_{OUT} = V_{FB} \left(1 + \frac{R_H}{R_L} \right) = n \times V_{F_MAX} + I_F \times R_{FB}$$

LEDs are PN junction devices with a steep I - V curve. For this reason, driving an LED with a voltage source can lead to large swings of forward current in response to even a small change in forward voltage. In general, to meet the needs of a driver for an HBLED, the current output must be in the $\pm 5\%$ to $\pm 20\%$ range.

The best way to drive the LEDs is to control the forward current so that it eliminates changes in current due to variations in forward voltage, which translates into a constant LED brightness. [Figure 2](#) illustrates the configuration of a typical buck converter driver circuit.

The value of current-sense resistor (R_{SENSE}) depends on the desired LED current and the feedback voltage that the buck converter requires. Multiple LEDs should be connected in a series configuration to keep an identical current flowing in each LED.

Figure 2. Constant current control

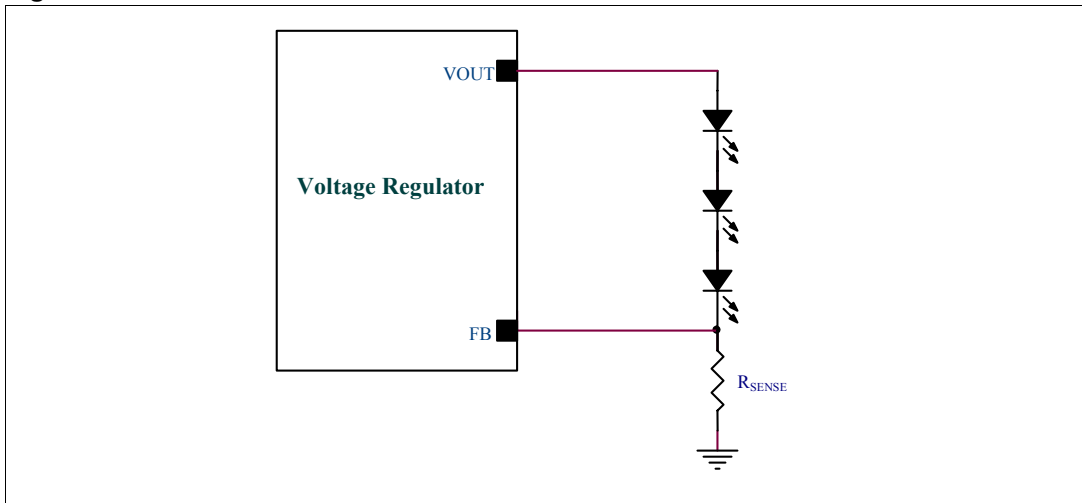

Equation 2

$$I_F = \frac{V_{FB}}{R_{FB}}$$

Accuracy and efficiency are the two main goals of the current sensing even if they are in direct conflict. The higher the sense voltage is, the higher the signal-noise ratio, but the higher the power dissipated on R_{SENSE} .

To reduce the power dissipated in the series resistance, [Figure 3](#) shows a simple method of amplifying the current sense signal by using a single supply op-amp. This method allows the user to select the current sense resistor R_{SENSE} according to the desired power dissipation while setting the average value of I_F with the gain of the op-amp.

Figure 3. Constant current control with V_{SENSE} amplification

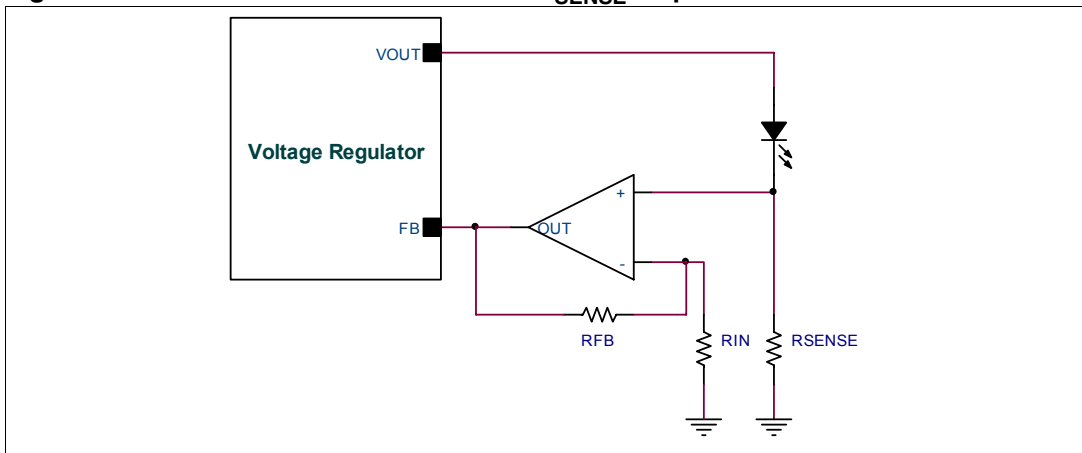

Equation 3

$$I_F = \frac{V_{FB}}{R_{SENSE} \cdot \left(1 + \frac{R_{FB}}{R_{IN}}\right)}$$

2 Buck topology switching power supply

The buck topology switching power supply is an efficient voltage regulator which produces an output voltage always less than or equal to the source voltage in the same polarity. The first step of conversion is to generate a chopped version of input source. A single-pole double-throw (SPDT) switch is connected as shown in [Figure 4](#).

Figure 4. Buck topology

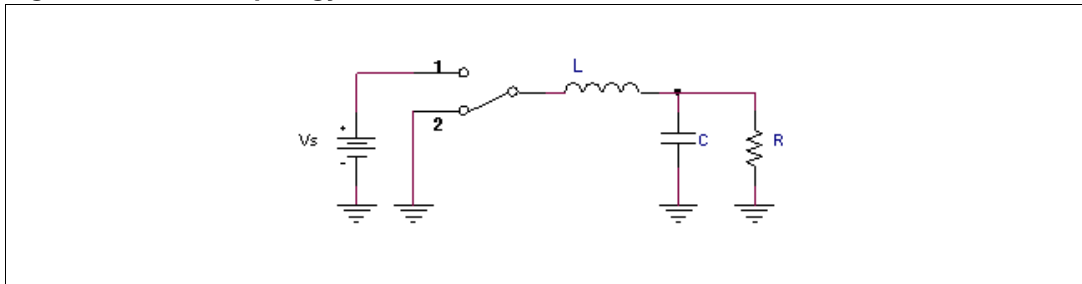

The switch output voltage is equal to the converter input voltage when the switch is in position 1 and equal to zero when the switch is position 2. The position is varied periodically at a frequency of $1/T$, where T represents the switching cycle period. The ratio of the on-time to the period is referred to as the duty cycle D . So the switch output is a rectangular waveform having amplitude equal to the source voltage, frequency equal to $1/T$ and duty cycle equal to D . By inserting a low-pass filter between the (SPDT) switch and the load, a basic buck topology is formed. The DC value of switch output voltage is simply the source voltage multiplied by the duty cycle. The L-C filter cutoff is selected to pass the desired low-frequency components of the switch output but also to attenuate the high-frequency switching harmonics.

A power stage can operate in continuous or discontinuous inductor current mode. Continuous inductor current mode is characterized by current flowing continuously in the inductor during the entire switching cycle in steady-state operation. In discontinuous mode the inductor current drops to zero for a portion of the switching cycle. In this section we will derive the voltage conversion relationship for the continuous conduction mode buck power stage. In continuous conduction mode, the power stage assumes two states per switching cycle.

The ON state is when the high-side switch is ON and the low-side switch is OFF.

Figure 5. Buck converter circuit while the switch is in position 1

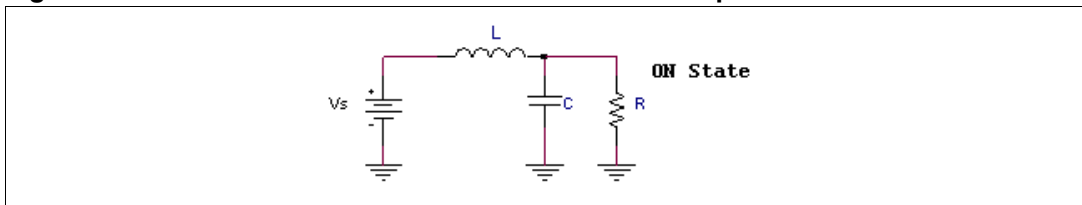

During the ON state the voltage applied on the inductor is given by:

Equation 4

$$v_L = V_s - V_{out}$$

We can find the inductor current by integrating the inductor voltage waveform.

Equation 5

$$i_L(nT + t) = i(nT) + \frac{V_S - V_{out}}{L} \cdot t$$

Figure 6. Inductor current waveform

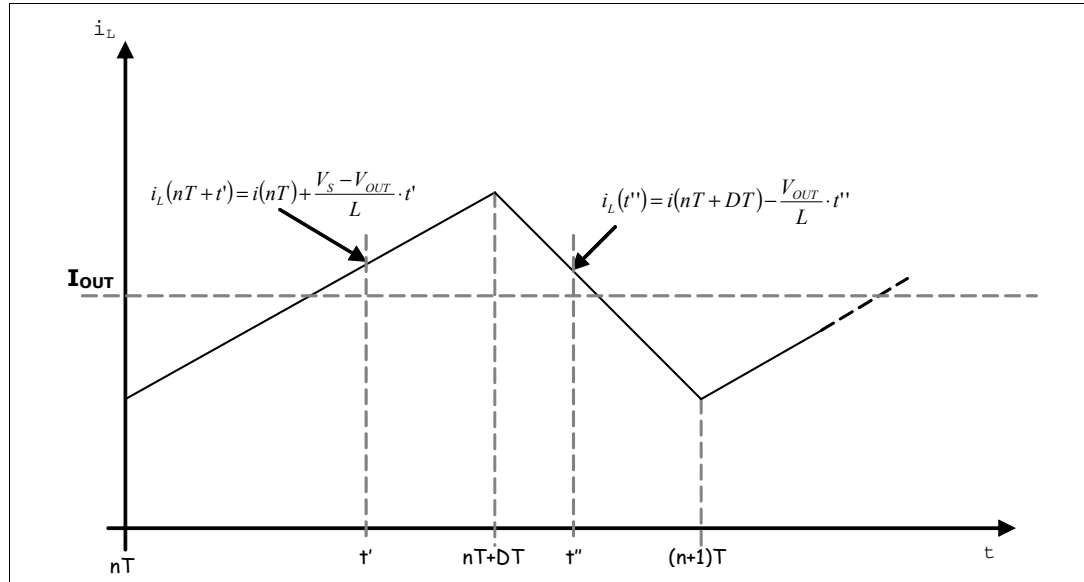

Equation 6

$$I_{Lmax} = i(nT) + \frac{V_S - V_{out}}{L} \cdot DT$$

The inductor current increase during the ON state is given by:

Equation 7

$$\Delta i_L = \frac{V_S - V_{out}}{L} \cdot DT$$

The OFF state is when the high side is OFF and the low side ON.

Figure 7. Buck converter circuit while the switch is in position 2

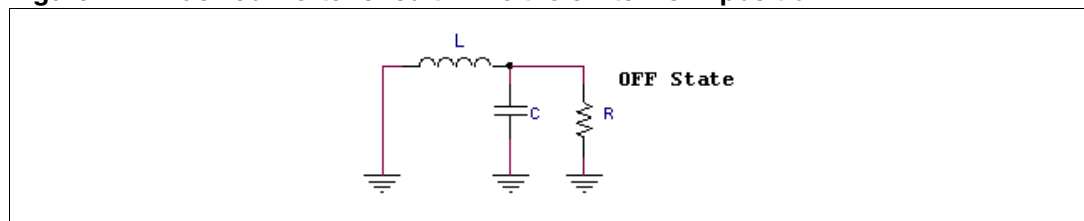

The inductor voltage during the OFF state is given by:

Equation 8

$$V_L = -V_{out}$$

The inductor current during the OFF state is given by:

Equation 9

$$i_L(t) = i(nT + DT) - \frac{V_{out}}{L} \cdot t$$

The inductor current decrease during the OFF state is given by:

Equation 10

$$\Delta i_L = \frac{V_{out}}{L} \cdot (1-D)T$$

The volt-time product of each switch state must be equal in steady-state operation, so the current increase during the ON state and the current decrease during the OFF state must be equal.

Equation 11

$$\frac{V_S - V_{out}}{L} \cdot DT = \frac{V_{out}}{L} \cdot (1-D)T$$

From the above equation we obtain the continuous conduction mode buck voltage conversion relationship.

Equation 12

$$V_{out} = D \times V_S$$

To guarantee continuous mode, the following equation must be satisfied:

Equation 13

$$I_{Lavg} = I_{LOAD} \geq \frac{\Delta i_L}{2}$$

The following relationship provides the minimum value of the inductance which is necessary to guarantee the fixed ripple current in continuous mode:

Equation 14

$$L_{MIN} = \frac{[V_{inMAX} - (R_{DSON} + ESR_L) \cdot I_{Lavg} - V_{out}] \cdot V_{out}}{\Delta i_L \cdot F_{SW}} \cdot \frac{V_{out}}{V_{inMAX}}$$

The function of the output capacitor is both filtering the AC current and providing the charge that is necessary to supply the load during the transients. Constant current drivers are free of load transient by design. For this reason, the capacitor is only needed to obtain a lower current ripple amplitude across the LEDs. The value of the output capacitor is chosen to

reduce the ripple current on the LEDs branch. To calculate the ripple current that flows through the LEDs it is necessary to estimate the impedances of the branches of both the LED and output capacitor (Z_o , Z_c). In this procedure let us suppose that the triangular shape of the ripple current on the inductor is approximately sinusoidal.

Figure 8. Output impedance

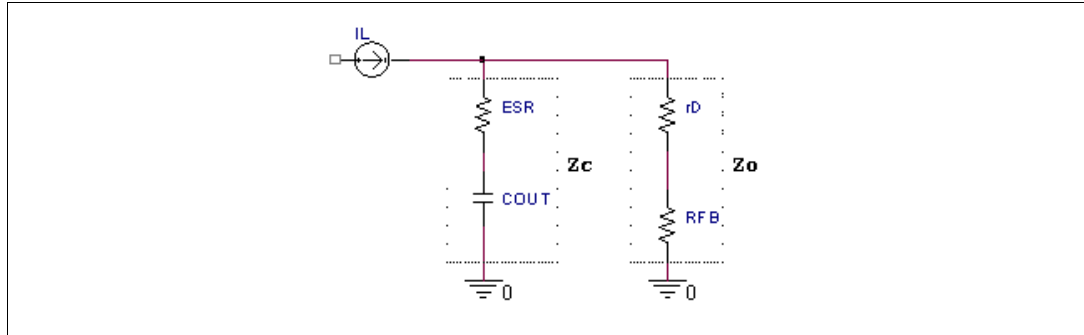

Equation 15

$$Z_o = rD + RFB$$

Equation 16

$$Z_c = ESR + \frac{1}{2 \cdot \pi \cdot F_{sw} \cdot C_{out}}$$

The following equation can be used to estimate the impedance of the output capacitor which guarantees the desired ripple current on the LEDs for a given inductor ripple current:

Equation 17

$$Z_c = \frac{\Delta i_{LED}}{\Delta i_L - \Delta i_{LED}} \times Z_o$$

3 Design example

This section outlines a step-by-step procedure for the design of a constant current control by means of a switching step-down voltage regulator. The aim is to maintain both high efficiency and good accuracy. The following design procedure is helpful in selecting the component values of the application.

3.1 Design parameters

LED manufacturers generally recommend values for ΔI_F ranging from $\pm 5\%$ to $\pm 20\%$ of I_F . The higher LED ripple allows the use of smaller inductors and smaller output capacitors. The advantages of higher ripple current are reductions in the solution size and cost. Lower ripple current requires more inductor output and more capacitor output. The advantages of a lower ripple current are reductions in heating of the LED itself and a greater range of the average LED current before the current limit is reached. The application is designed to supply up to four HBLEDs. The LED used in the application is a Lumileds LUXEON III Emitter LXHL-PW09 with a typical forward voltage of 3.7 V at 700 mA.

[Table 1](#) provides a summary of the specifications of a particular application.

Table 1. Performance specification summary

	Symbol	Value	Unit
Input source 4 AA batteries	V_{in}	6	V
White LED		LUXEON III Emitter LXHL-PW09	
LED forward voltage	V_F	3.7 at 700 mA	V
I_{LEDavg} = Average inductor current	I_{LED}	1	A
Ripple current on the inductor ($\%I_{Lavg}$)	$\Delta I_L = \% I_{LED}$	60	%
Ripple current on the LED branch ($\%\Delta I_{LED}$)	$\Delta I_{LED} = \% I_{LED}$	10	%

3.2 Power stage selection

For the power stage we use the ST1S10 which is a general-purpose voltage regulator step-down DC-DC converter which has been optimized for high-efficiency small-sized equipment. A high switching frequency (900 kHz) allows the use of tiny surface-mount components. The synchronous rectification is implemented in order to obtain efficiency higher than 90%.

The ST1S10 provides up to 3 A over an input voltage range from 2.5 V to 16 V.

The minimum input voltage to maintain regulation, depending on the load current and output voltage, can be calculated as:

Equation 18

$$V_{inmin} = \frac{V_{OUT}}{D_{MAX}} + I_{LED} \cdot (R_L + R_{DS_ONmax})$$

where $R_{DS(on)}$ is the maximum PMOS switch-on resistance, R_L is the DC resistance of the inductor and V_{OUT} is the nominal output voltage.

3.3 Current sense

Amplifying the sensed voltage is a way to reduce the power loss in the current sense resistor. The operational amplifier selected for this application must be able to work with a common mode input voltage close to zero. The selected device is the TS951, a rail-to-rail BiCMOS operational amplifier. The value of the current sense resistor is determined by two factors: power dissipation on R_{SENSE} and the threshold level for amplifier input. Smaller R_{SENSE} reduces power dissipation but the detection of the feedback signal is more difficult. In order to keep the power dissipation for the current sensing at a minimum value, a good choice for the sense voltage with a forward current of 1 A is 100 mV.

The ratio between feedback voltage and sense voltage gives the value of the gain of the amplification stage:

Equation 19

$$\text{Gain} = \frac{V_{FB}}{I_{LED} \times R_{SENSE}}$$

$$\text{Gain} = \frac{0.8}{1 \times 0.1} = 8$$

3.4 Inductor selection

The buck power stage is designed to operate in continuous mode for load current greater than 30% of full load. We choose an inductor value producing a maximum peak-peak ripple current equal to sixty percent of the maximum load current. This limits the RMS current in the output filter capacitor and, as a second order effect, keeps the core losses in the inductor reasonable.

By using a single HBLED in conjunction with the chosen current sense resistor the output voltage is given by the following equation:

Equation 20

$$V_{OUT} = V_F + V_{SENSE} = 3.8 \text{ V} + 0.1 \text{ V} = 3.9 \text{ V}$$

Let us set the value of the ripple current equal to 60% of the average current:

Equation 21

$$\Delta I_L = 0.6 \times I_{LED\text{AVG}} = 0.6 \times 1 = 0.6 \text{ A}$$

The minimum value of the output current to guarantee continuous mode is given by:

Equation 22

$$I_{LED\text{minCCM}} = \Delta I_L / 2 = 0.6 / 2 = 300 \text{ mA}$$

The minimum value of inductance which guarantees a ripple current of 300 mA can be calculated using [Equation 14](#):

Equation 23

$$L_{\text{MIN}} = \frac{[V_{\text{inMAX}} - (R_{\text{DSON}} + \text{ESR}_L) \cdot I_{\text{Lavg}} - V_{\text{out}}]}{\Delta I_L \cdot F_{\text{SW}}} \cdot \frac{V_{\text{out}}}{V_{\text{inMAX}}}$$

3.5 Output capacitor selection

The target tolerance for the LED ripple current is 10% of the forward current. In this particular example the forward current is 1 A and the ripple current on LEDs branch is 100 mA. In current-mode converters, the load consists of the dynamic resistance of the diodes, r_D and the operating point resistance V_O/I_{LED} . Typical values for r_D are provided by LED manufacturers and for those do not, it must be determined by examining the slope of the I-V curve that is provided in all LED datasheets.

The LUXEON III Emitter LXHL-PW09 datasheet gives a typical value for the dynamic resistance r_D of 0.8 Ω at 700 mA. Given the ripple current on the inductor with the equation below, it is possible to calculate the Z_C impedance to guarantee a ripple current on LEDs branch equal to 10% of I_F :

Equation 24

$$Z_C = \frac{Z_O \cdot \Delta i_{\text{LED}}}{\Delta i_L - \Delta i_{\text{LED}}}$$

$$Z_C = \frac{(0.8 + 0.1) \times 0.05}{(0.3 - 0.05)} = 0.18 \Omega$$

A ceramic capacitor is used and the required capacitance is selected based on the impedance at 900 kHz.

Equation 25

$$C = 1/[2 \times \pi \times (Z_C - \text{ESR}) \times f_{\text{SW}}]$$

$$C = 1/[2 \times \pi \times (0.18 - 0.01) \times 900 \cdot 10^3] = 1$$

3.6 Input capacitor selection

Because of the pulsating input current nature of the buck converter, a low ESR input capacitor is required. A good input voltage filtering is important for minimizing the interference with other circuits caused by high input voltage spikes. The following equation is used to calculate the input ripple voltage due to capacitance and ESR:

Equation 26

$$\Delta V_{\text{inpp}} = I_{\text{in}} \cdot R_{\text{ESR}} + I_{\text{in}} \cdot \frac{D}{F_{\text{SW}} \cdot C}$$

A 4.7 μF input capacitor is sufficient for effective input voltage filtering.

4 Description of the board

The evaluation board is configured as constant current supply. Current regulation is accomplished by regulating the voltage across a current sense resistor

4.1 Input/output connection

The following table describes the input/output connections.

Table 2. Input/output connections

Reference designator	Name	Description
J1	LED cathode	Output to cathode of LED
J2	LED anode	Output to anode of LED
J3	Supply/sync	VIN_SW: Power input supply voltage to be tied to VIN_A. (VIN_SW max=18 V) VIN_A: Analog input supply voltage to be tied to VIN_SW. (VIN_A max=18 V) SYNC: Synchronization and frequency select. Connect SYNC to GND for 900 kHz switching frequency or connect to an external clock from 400 kHz to 1.2 MHz.
J4	Enable	Use this connector to enable and disable DC-DC converter. Connect a jumper between the ON pin and the center pin to enable the supply. Connect a jumper between the OFF pin and the center pin to disable the supply. If this pin is left open, the EVM does not operate correctly. This pin is also used for PWM dimming control of the LED current.

5 Schematic and bill of material (1 A LED current)

Figure 9. Schematic - LED current 1 A

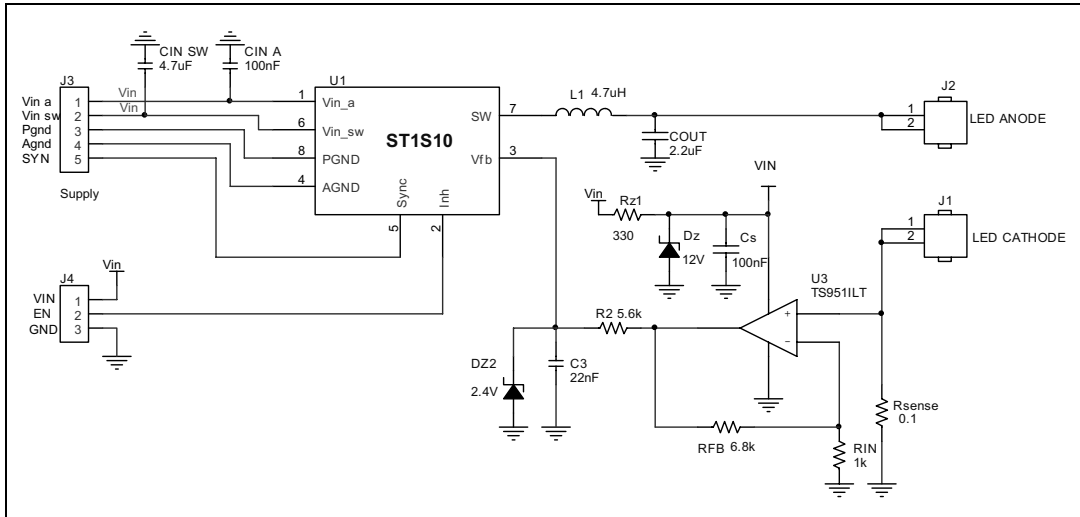

Table 3. Bill of material

Quantity	Reference	Part/value	PCB footprint
2	Cs, C _{IN A}	100 nF	SM/C_0805
1	C _{IN SW}	4.7 µF	SM/C_1210
1	C _{OUT}	2.2 µF	SM/C_1210
1	C3	22 nF	SM/C_0805
1	D3	12 V	SM/D_1406
1	J1	LED cathode	SIP/TM/L.200/2
1	J2	LED anode	SIP/TM/L.200/2
1	J3	Supply	SIP/TM/L.500/5
1	J4	Inh	SIP/TM/L.300/3
1	L1	4.7 µF	SM/L_2220
1	RFB	6.8 kΩ	SM/R_0805
1	RIN	1 kΩ	SM/R_0805
1	R _{SENSE}	0.1	SM/R_0805
1	Rz	330	SM/R_0805
1	R2	5.6 kΩ	SM/R_0805
1	U1	ST1S10	VDFPN 8L 4X4
1	U2	TS9511LT	SOT23-5

Figure 11. Top layer

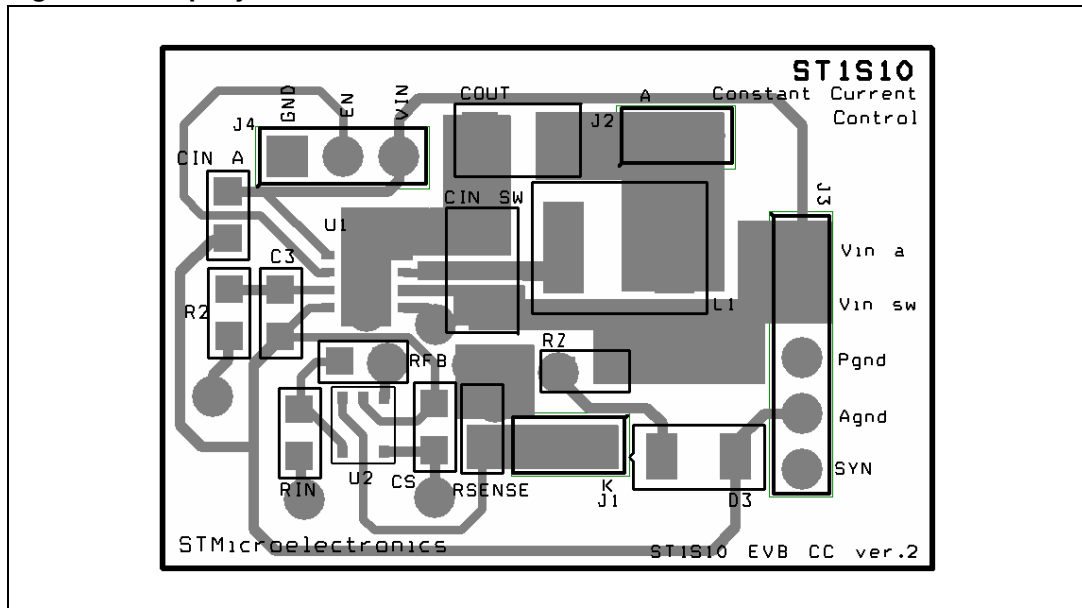
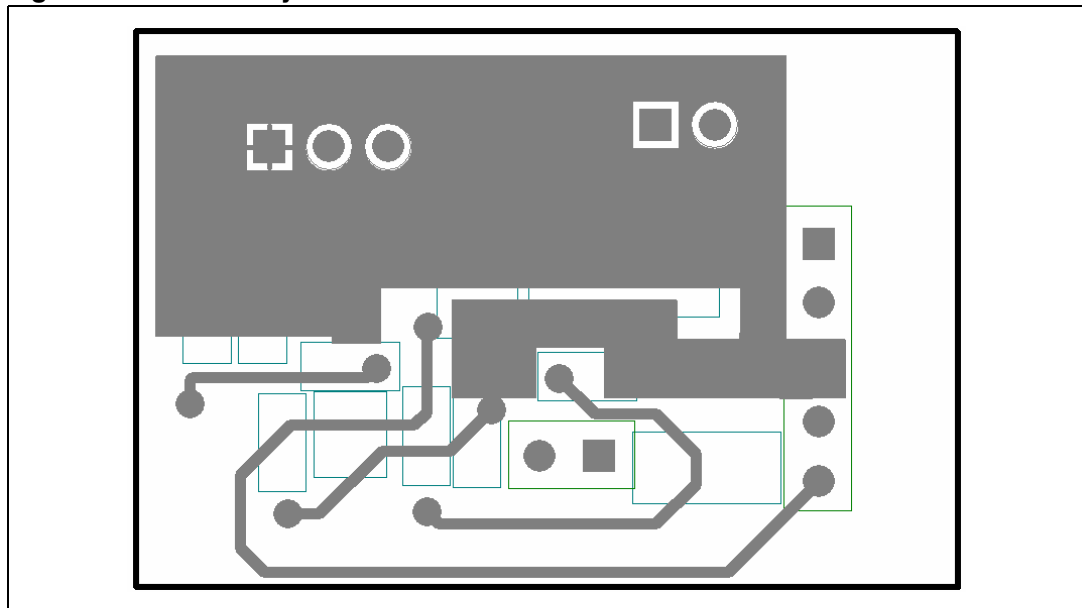

Figure 12. Bottom layer



7 Typical application waveforms

7.1 Startup

Figure 13. Startup

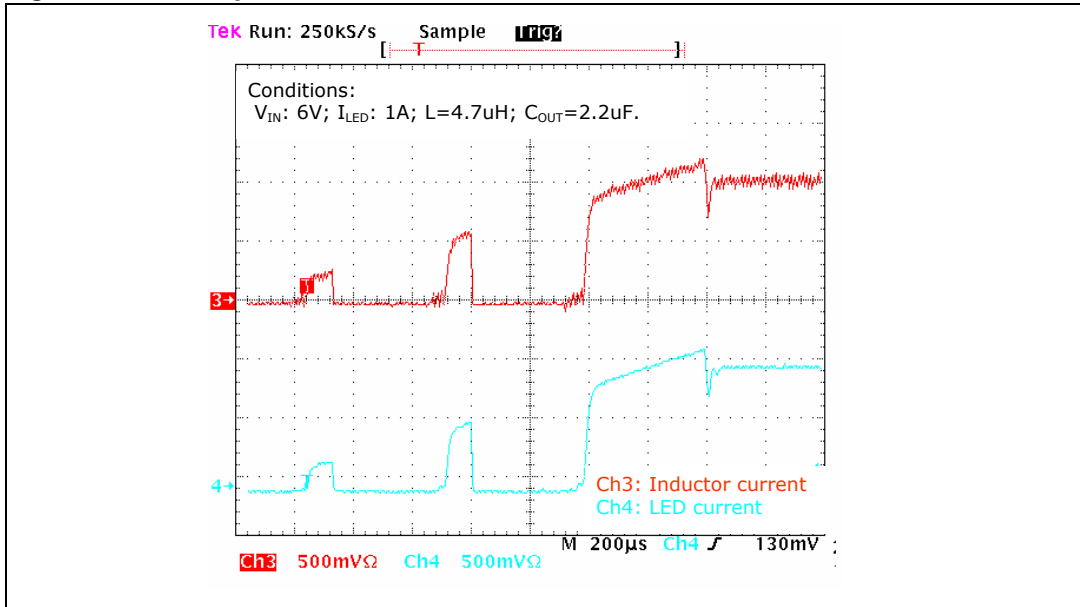

7.2 Switching waveform

Figure 14. Steady-state operation

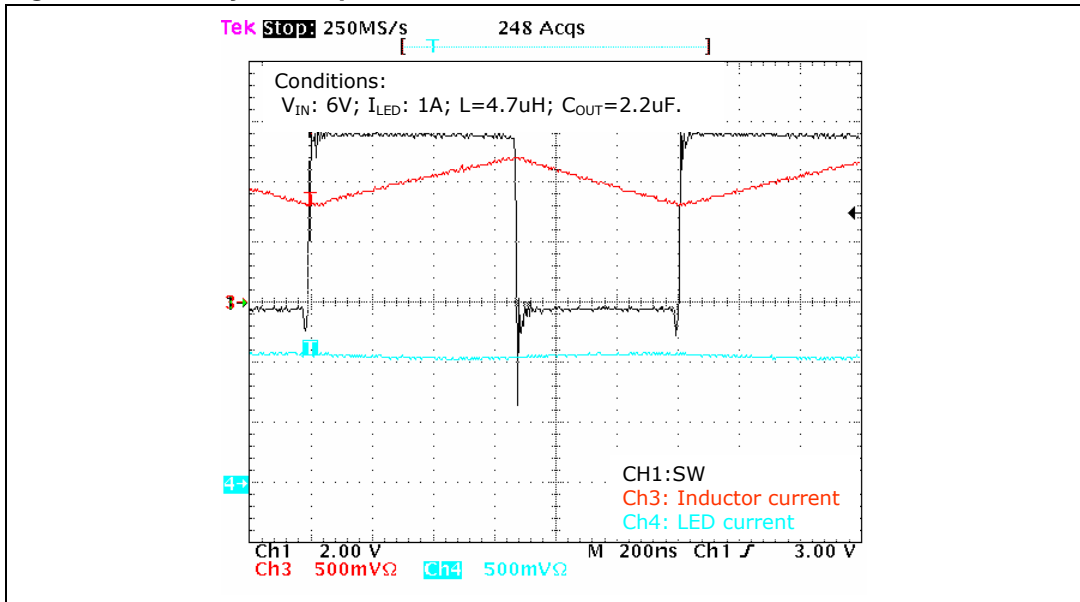

7.3 PWM dimming using the enable function

Figure 15. PWM dimming

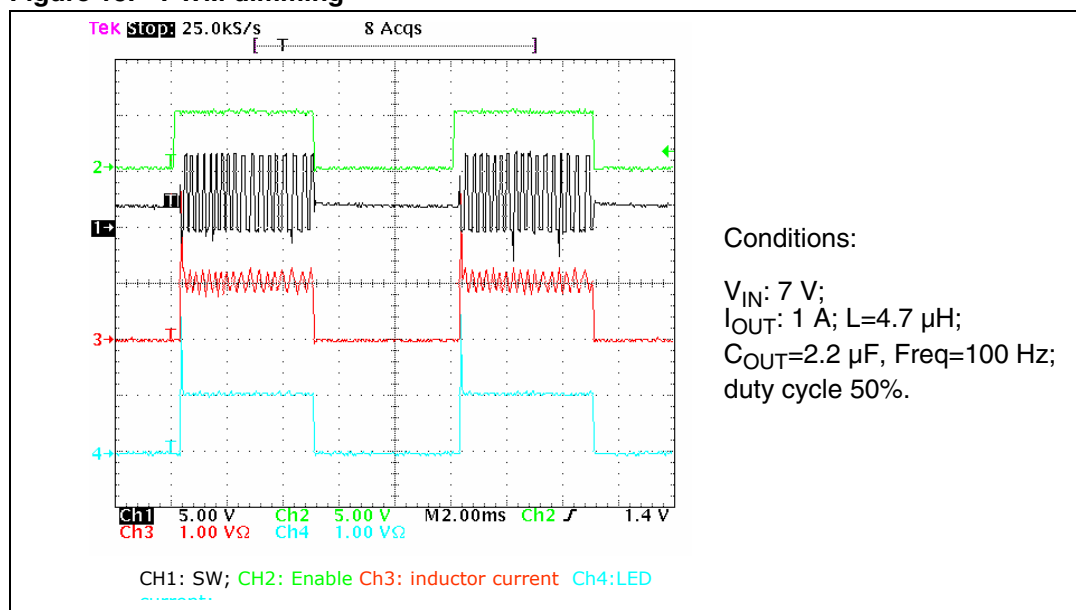

8 Revision history

Table 4. Document revision history

Date	Revision	Changes
28-Aug-2008	1	Initial release

Please Read Carefully:

Information in this document is provided solely in connection with ST products. STMicroelectronics NV and its subsidiaries ("ST") reserve the right to make changes, corrections, modifications or improvements, to this document, and the products and services described herein at any time, without notice.

All ST products are sold pursuant to ST's terms and conditions of sale.

Purchasers are solely responsible for the choice, selection and use of the ST products and services described herein, and ST assumes no liability whatsoever relating to the choice, selection or use of the ST products and services described herein.

No license, express or implied, by estoppel or otherwise, to any intellectual property rights is granted under this document. If any part of this document refers to any third party products or services it shall not be deemed a license grant by ST for the use of such third party products or services, or any intellectual property contained therein or considered as a warranty covering the use in any manner whatsoever of such third party products or services or any intellectual property contained therein.

UNLESS OTHERWISE SET FORTH IN ST'S TERMS AND CONDITIONS OF SALE ST DISCLAIMS ANY EXPRESS OR IMPLIED WARRANTY WITH RESPECT TO THE USE AND/OR SALE OF ST PRODUCTS INCLUDING WITHOUT LIMITATION IMPLIED WARRANTIES OF MERCHANTABILITY, FITNESS FOR A PARTICULAR PURPOSE (AND THEIR EQUIVALENTS UNDER THE LAWS OF ANY JURISDICTION), OR INFRINGEMENT OF ANY PATENT, COPYRIGHT OR OTHER INTELLECTUAL PROPERTY RIGHT.

UNLESS EXPRESSLY APPROVED IN WRITING BY AN AUTHORIZED ST REPRESENTATIVE, ST PRODUCTS ARE NOT RECOMMENDED, AUTHORIZED OR WARRANTED FOR USE IN MILITARY, AIR CRAFT, SPACE, LIFE SAVING, OR LIFE SUSTAINING APPLICATIONS, NOR IN PRODUCTS OR SYSTEMS WHERE FAILURE OR MALFUNCTION MAY RESULT IN PERSONAL INJURY, DEATH, OR SEVERE PROPERTY OR ENVIRONMENTAL DAMAGE. ST PRODUCTS WHICH ARE NOT SPECIFIED AS "AUTOMOTIVE GRADE" MAY ONLY BE USED IN AUTOMOTIVE APPLICATIONS AT USER'S OWN RISK.

Resale of ST products with provisions different from the statements and/or technical features set forth in this document shall immediately void any warranty granted by ST for the ST product or service described herein and shall not create or extend in any manner whatsoever, any liability of ST.

ST and the ST logo are trademarks or registered trademarks of ST in various countries.

Information in this document supersedes and replaces all information previously supplied.

The ST logo is a registered trademark of STMicroelectronics. All other names are the property of their respective owners.

© 2008 STMicroelectronics - All rights reserved

STMicroelectronics group of companies

Australia - Belgium - Brazil - Canada - China - Czech Republic - Finland - France - Germany - Hong Kong - India - Israel - Italy - Japan - Malaysia - Malta - Morocco - Singapore - Spain - Sweden - Switzerland - United Kingdom - United States of America

www.st.com