



An alternative solution to Capacitive power supply using Buck converter based on VIPer12A

Introduction

In this paper three different power supplies with two outputs are introduced: a Capacitive passive network, and two versions of a low cost SMPS Buck converter. The last two are based on VIPer12A, a high voltage Power MOSFET with a dedicated current mode PWM controller, start-up circuit and protection integrated on the same silicon chip by STMicroelectronics.

The considered converters are compared in terms of output voltage regulation, efficiency and EMI, under the same output power conditions (about 0.6W).

Finally some modifications to the Buck converters are presented, in order to extend the output power level to higher values, up to 1.1W.

The main specifications of the converters are listed in [Table 1](#).

Table 1. Power supplies main specifications

AC input voltage V_{IN}	$185\div 265V_{AC}$
Outputs	$V_{out1}=12V; I_{out1}=30mA$
	$V_{out2}=5V; I_{out2}=40mA$
Total output power	0.6W

Contents

1	Capacitive converter	5
2	Modified Buck converter	6
2.1	Experimental results	10
2.2	EMI measurements	12
2.3	Higher output power	13
2.4	Efficiency comparison	16
2.5	Different output voltages	16
3	Conclusions	19
4	Revision history	20

Figures

Figure 1.	Capacitive converter schematic	5
Figure 2.	Buck converter modified schematic	6
Figure 3.	Buck basic operation during the switch TON	7
Figure 4.	Buck basic operation during the switch TOFF	7
Figure 5.	Modified Buck current flow at $I_{out2} = 0$	7
Figure 6.	Modified Buck current flow at $I_{out2} \neq 0$	7
Figure 7.	Buck converter with VIPer12A, schematic A (Vout1 referred to GND)	8
Figure 8.	Buck with VIPer12A, schematic B (Vout1 referred to -5V)	8
Figure 9.	PCB layout based on schematic B	9
Figure 10.	Buck waveforms (schematic A) @230VAC, full load; Ch1=VS, Ch2=Vout2, Ch3=Vout1, Ch4=IL	10
Figure 11.	Buck waveforms (schematic B) @230VAC, full load; Ch1=VS, Ch2=Vout2, Ch3-Ch2=Vout1, Ch4=IL	10
Figure 12.	Capacitive converter line regulation, at full load	11
Figure 13.	Buck converter line regulation (schematic A), at full load	11
Figure 14.	Buck converter line regulation (schematic B), at full load	11
Figure 15.	Efficiency vs V_{in}	12
Figure 16.	Capacitive converter: conducted emission @ 230VAC, full load: Phase	12
Figure 17.	Capacitive converter: conducted emission @ 230VAC, full load: Neutral	12
Figure 18.	Buck converter: conducted emission @ 230VAC, full load: Phase	13
Figure 19.	Buck converter: conducted emission @ 230VAC, full load: Neutral	13
Figure 20.	Line regulation @full load (Buck converter, schematic A)	14
Figure 21.	Line regulation @full load (Buck converter, schematic B)	14
Figure 22.	Out1 load regulation @ $I_{out2} = 0$ (Buck converter, schematic A)	14
Figure 23.	Out2 load regulation @ $I_{out1} = 20\text{mA}$ (Buck converter, schematic A)	14
Figure 24.	Out1 load regulation @ $I_{out2} = 0$ (Buck converter, schematic B)	15
Figure 25.	Out2 load regulation @ $I_{out1} = 20\text{mA}$ (Buck converter, schematic B)	15
Figure 26.	Efficiency vs V_{in}	15
Figure 27.	Efficiency comparison between schematics A and B for $I_{Dz2} = 30\text{mA}$	16
Figure 28.	Schematic A modifications for $4\text{V} < V_{out1} < 11\text{V}$ (Vout2 @ 5V)	17
Figure 29.	Schematic B modifications for $9\text{V} < V_{out1} < 16\text{V}$ (Vout2 @ 5V)	17

Tables

Table 1.	Power supplies main specifications	1
Table 2.	Capacitive converter part list	5
Table 3.	Buck converter part list (schematic A)	9
Table 4.	Buck converter part list (schematic B)	9
Table 5.	Higher output power requirements	13
Table 6.	Schematics A and B part list modification.	14
Table 7.	Document revision history	20

1 Capacitive converter

The schematic of the Capacitive power supply is shown in [Figure 1](#). The capacitor C2 accommodates the AC mains voltage to a voltage level suitable for the application, while R1 and R2 are connected in order to limit the inrush current of the capacitors. The voltage is then rectified by the diode D1 and regulated by means of zener diodes and electrolytic capacitors. The output capacitor values, C4 and C6, have been chosen in order to keep the output voltages ripples below 5%, at the given output load condition. The part list of the converter is given in [Table 2](#).

Figure 1. Capacitive converter schematic

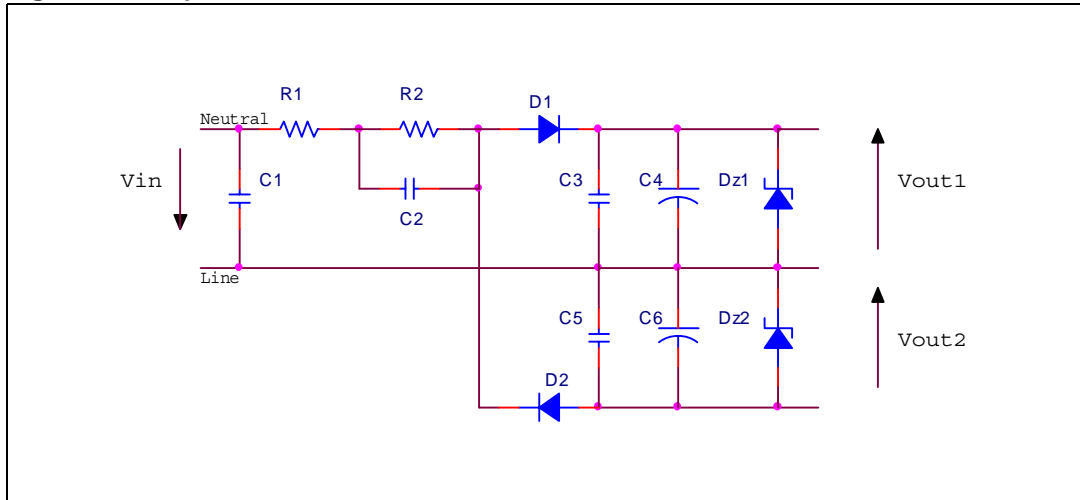

Table 2. Capacitive converter part list

Reference	Value	Part type
R1	10 Ω 1/4 Ω	Resistor
R2	150K Ω 1/4 Ω	Resistor
C1	47nF	X2 Capacitor
C2	2.2 μ F	X2 Capacitor
C3	82nF	Ceramic capacitor
C4	10002 μ F, 25V	Electrolytic Capacitor
C5	82nF	Ceramic capacitor
C6	4700 μ F, 25V	Electrolytic Capacitor
D1		Diode 1N4007
D2		Diode 1N4007
Dz1	12V	Zener Diode 1N5349B730
Dz2	5.1V	Zener Diode BZX85C5V1

2 Modified Buck converter

The considered circuit is based on the modified Buck converter shown in figure 2. It provides two outputs with reversed polarity, $V_{out1} = 12V$ and $V_{out2} = -5V$.

Figure 2. Buck converter modified schematic

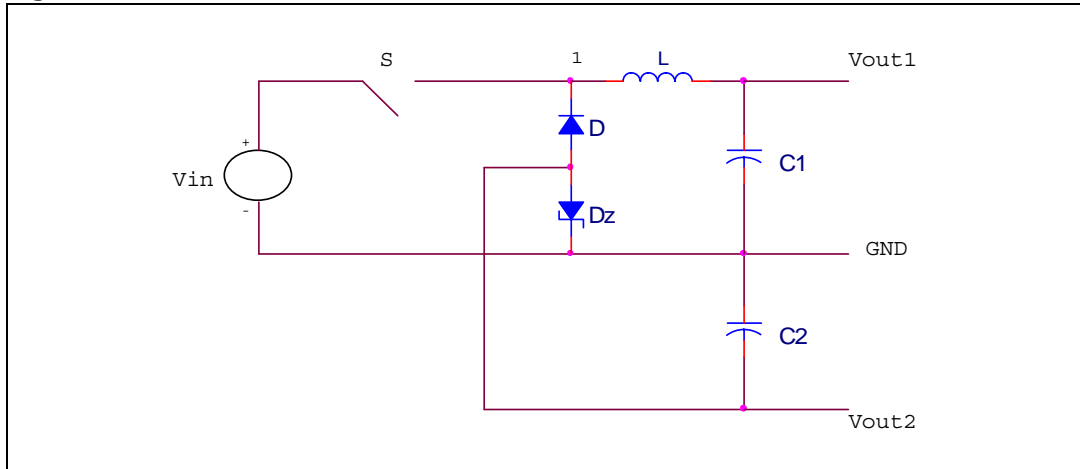

The second complementary output, V_{out2} , is generated charging the capacitor C2 during the free-wheeling of the inductor current. The voltage across such a capacitor is regulated by means of a zener diode of suitable value. The power switch, S, operates at high frequency for power conversion. The voltage is then filtered by the LC filter made up by L and C1.

In the standard Buck topology, the voltage of the node 1 is clamped by the diode D, allowing the free-wheeling of the inductor current. In the proposed solution, the zener diode, D_z , clamps such a voltage to $(V_D + V_Z)$, where V_D is the voltage drop across the diode D, and V_Z is the zener voltage. If a capacitor is connected across the anode of the zener and the ground, a negative voltage source is generated. Of course, due to the principle of operation, the second output cannot supply more current than the first one.

The switching cycle can be basically divided in two periods as shown in [Figure 3.](#) and [Figure 4.](#) Considering discontinuous conduction mode (DCM), during the conduction of the switch S the input DC bus is connected to the output and supplies the load, as shown in [Figure 3.](#) Once the switch is turned off, the inductor current free-wheels through the diode D_1 , as shown in [Figure 4.](#), until it zeroes and the output capacitor C1 feeds the load.

Figure 3. Buck basic operation during the switch T_{ON}

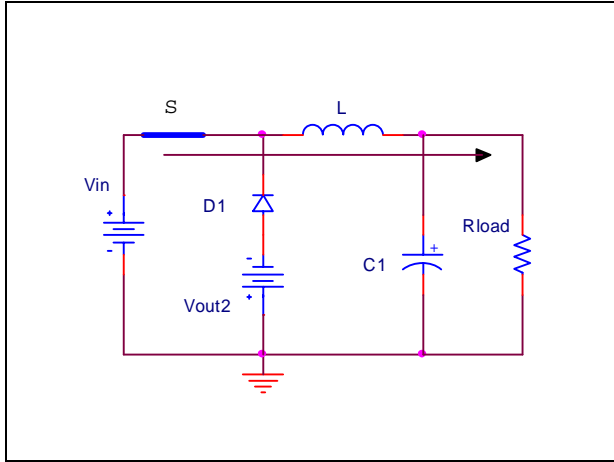
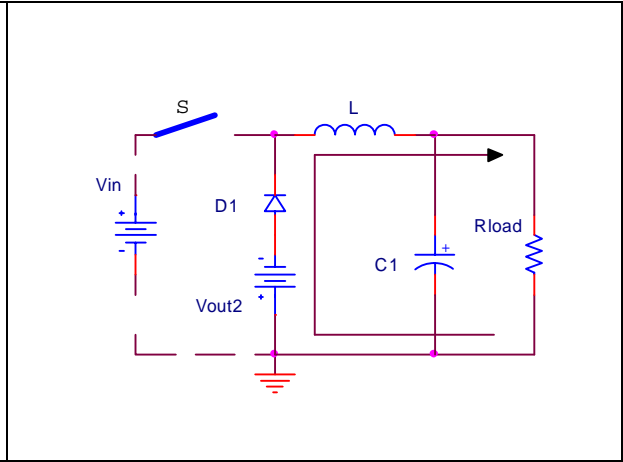

Figure 4. Buck basic operation during the switch T_{OFF}



The presence of the zener diode in the free-wheeling path does not affect the basic operation of the converter, but it could impact on the efficiency. In fact, if there is no load on V_{out2} , the whole free-wheeling current will flow through both diodes, D_1 and D_Z , as shown in [Figure 5.](#)

Figure 5. Modified Buck current flow at $I_{out2} = 0$

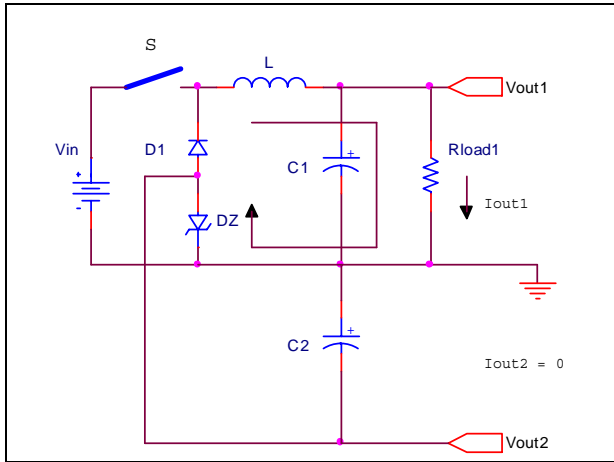
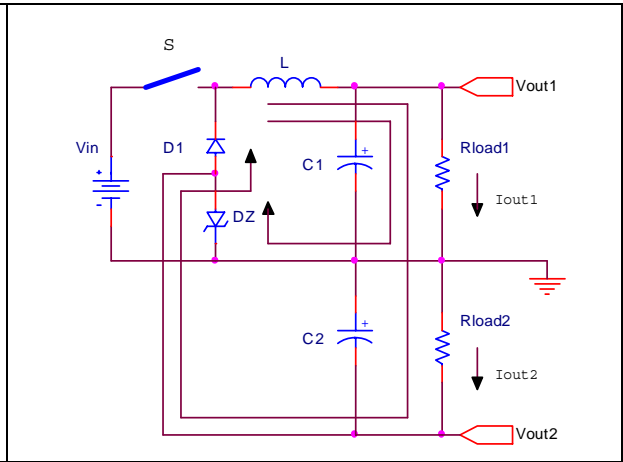

Figure 6. Modified Buck current flow at $I_{out2} \neq 0$



As the current drawn from V_{out2} increases, the free-wheeling current flows through a different path, splitting in two components as shown in [Figure 6.](#) In this way the power dissipation in D_Z is reduced and the efficiency is increased accordingly. Thus, the converter performs better if the complementary output is loaded, for a given output current I_{out1} .

In order to guarantee the proper operation of the converter when V_{out1} is in open load condition, a bleeder resistor has to be connected.

A practical implementation of the circuit is presented in schematic A (see figure [Figure 7.](#)), where $R1$ is the bleeder resistor; $D3$, $C3$ and $C4$ are needed for VIPer12A biasing; $L1$, $C1$, $D1$, $C2$ make up the input filter for EMI compliance; $R0$ limits the inrush current of the capacitors.

Figure 7. Buck converter with VIPer12A, schematic A (V_{out1} referred to GND)

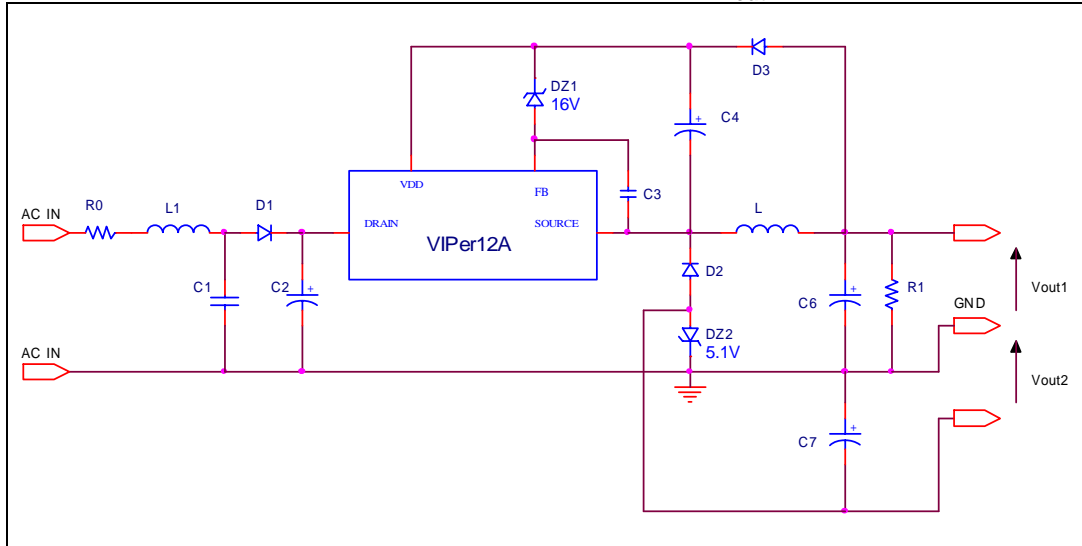

Due to the connection of the bleeder resistor, a constant power loss appears in the circuit of [Figure 7.](#), given by (1):

$$P_L = \frac{V_{R1}^2}{R1} = \frac{V_{out1}^2}{R1} \quad (1)$$

Referring V_{out1} to -5V output, the circuit schematic B shown in [Figure 8.](#) can be used: in such a case the voltage drop across the bleeder is only $(V_{out1} - V_{out2})$ instead of V_{out1} .

Figure 8. Buck with VIPer12A, schematic B (V_{out1} referred to -5V)

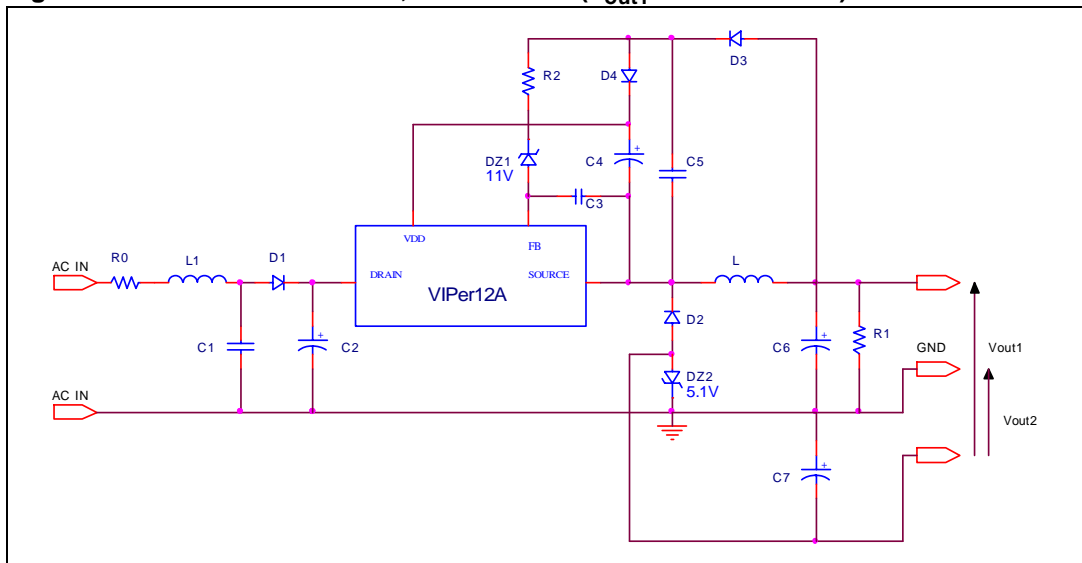

The part lists of the proposed circuits are given in [Table 3.](#) and [Table 4.](#) A lab prototype based on schematic B (see [Figure 8.](#)) has been built using the layout shown in [Figure 9.](#)

Figure 9. PCB layout based on schematic B

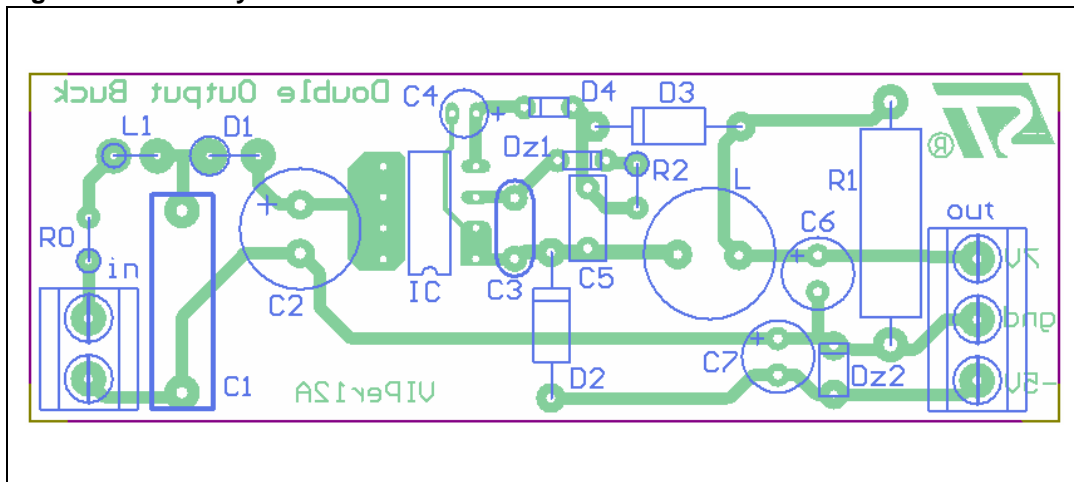

Table 3. Buck converter part list (schematic A)

Reference	Value	Part type
R0	22Ω 1/2W	Resistor
R1	330Ω 1/2W	Resistor (bleeder)
C1	47nF	X2 capacitor
C2	2.2μF, 400V	Electrolytic capacitor
C3	22nF	Ceramic capacitor
C4	4.7μF, 63V	Electrolytic capacitor
C6	33μF, 25V	Electrolytic capacitor
C7	33μF, 25V	Electrolytic capacitor
D1		Diode 1N4004
D2		Diode STTA106
D3		Diode BA157
Dz1	16V	Zener Diode
Dz2	5.1V, 1/2W	Zener Diode
L1	1mH	Axial inductor
L	1.5mH	Axial inductor
IC		VIPer12A - DIP8

Table 4. Buck converter part list (schematic B)

Reference	Value	Part type
R0	22Ω 1/2W	Resistor
R1	120Ω 1/2W	Resistor (bleeder)
R2	1kΩ 1/4W	Resistor

Table 4. Buck converter part list (schematic B)

Reference	Value	Part type
C1	47nF	X2 capacitor
C2	2.2μF, 400V	Electrolytic capacitor
C3	22nF	Ceramic capacitor
C4	4.7μF, 63V	Electrolytic capacitor
C5	470nF	Ceramic capacitor
C6	33μF, 25V	Electrolytic capacitor
C7	33μF, 25V	Electrolytic capacitor
D1		Diode 1N4004
D2		Diode STTA106
D3		Diode BA157
D4		Diode 1N4148
Dz1	11V	Zener Diode
Dz2	5.1V, 1/2W	Zener Diode
L1	1mH	Axial inductor
L	1.5mH	Axial inductor
IC		VIPer12A - DIP8

2.1 Experimental results

In [Figure 10](#). and [Figure 11](#). the typical waveforms of the Buck converters are shown, at $V_{in} = 230V_{AC}$ and full load (i.e. $I_{out1} = 30mA$ and $I_{out2} = 40mA$).

Figure 10. Buck waveforms (schematic A)
 @230V_{AC}, full load; Ch1=V_S,
 Ch2=V_{out2}, Ch3=V_{out1}, Ch4=I_L

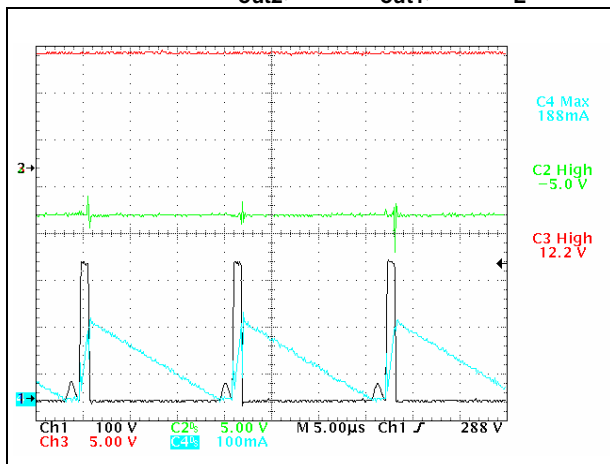
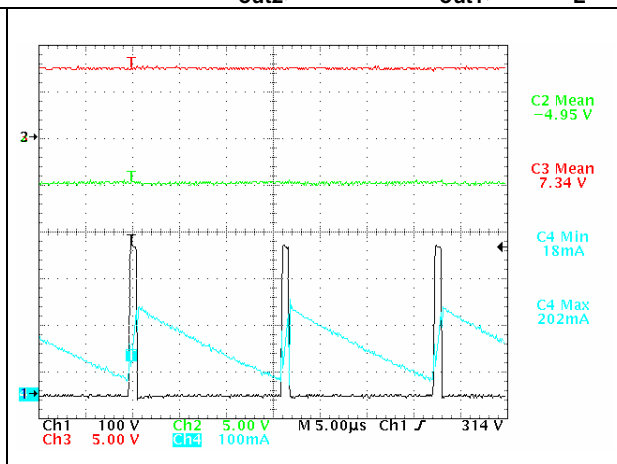

Figure 11. Buck waveforms (schematic B)
 @230V_{AC}, full load; Ch1=V_S,
 Ch2=V_{out2}, Ch3-Ch2=V_{out1}, Ch4=I_L



Line regulation diagrams are shown in [Figure 12.](#), [Figure 13.](#) and [Figure 14.](#) for the Capacitive and the Buck converters respectively.

Figure 12. Capacitive converter line regulation, at full load

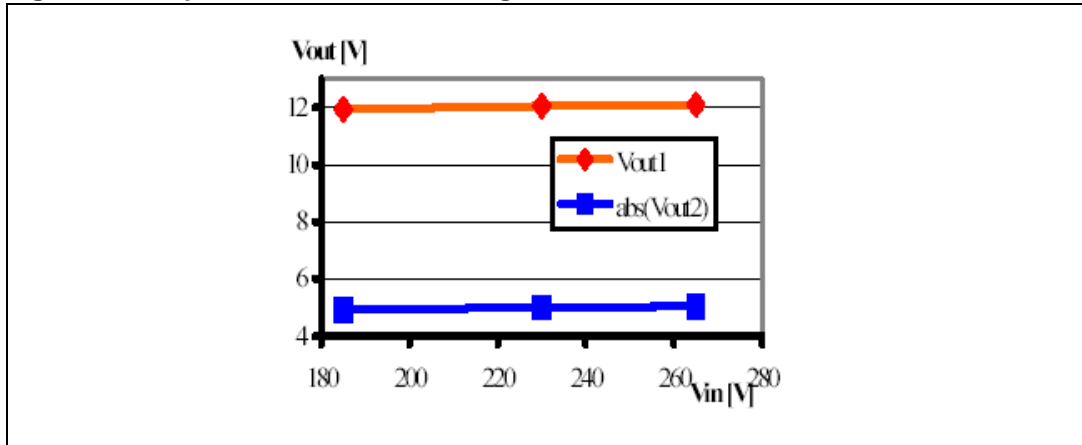

Figure 13. Buck converter line regulation (schematic A), at full load

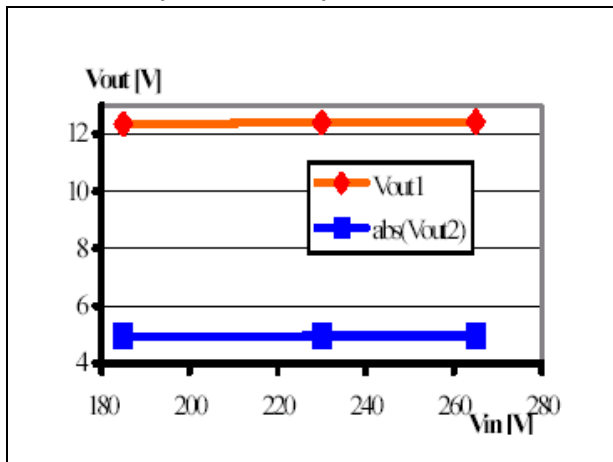
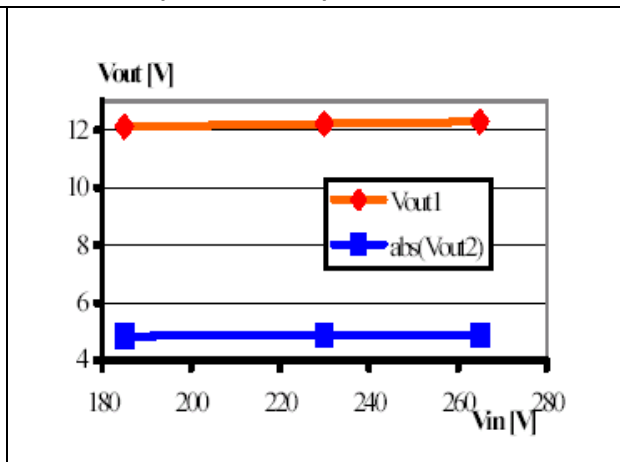
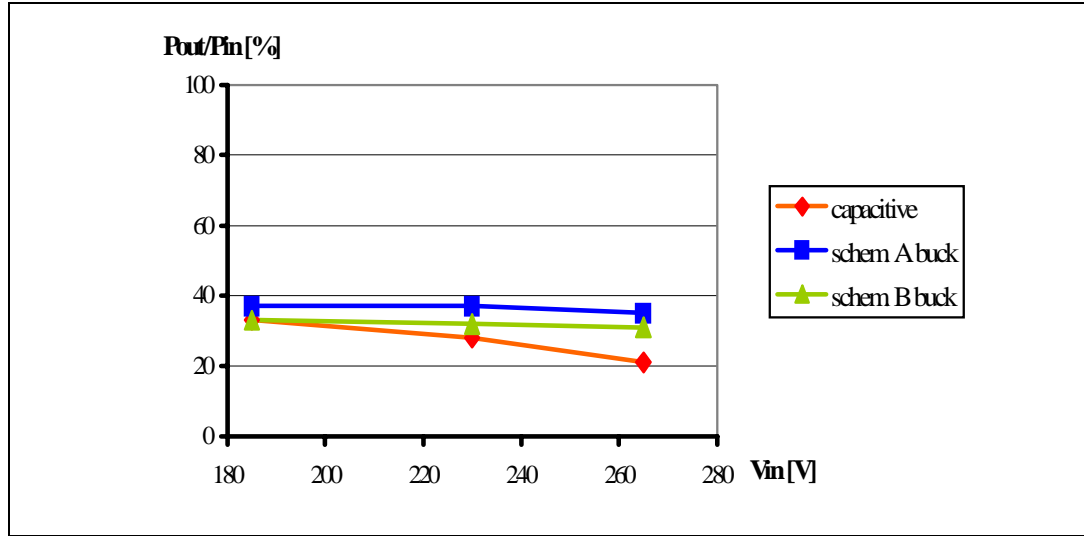

Figure 14. Buck converter line regulation (schematic B), at full load



The efficiency ($\eta = P_{OUT} / P_{IN}$) of the power supplies has been evaluated at the same output power value (about 0.6W), in the whole input voltage range. The results are shown in [Figure 15.](#)

Figure 15. Efficiency vs V_{in}



2.2 EMI measurements

Conducted EMI measurements have been performed according to EN55022 Class B standard, using a 50Ω LISN and a spectrum analyzer.

In [Figure 16.](#), [Figure 17.](#), [Figure 18.](#) and [Figure 19.](#), Phase and Neutral measurement results are shown under full load conditions at nominal 230V_{ac} input voltage.

Figure 16. Capacitive converter: conducted emission @ 230V_{AC}, full load: Phase

Figure 17. Capacitive converter: conducted emission @ 230V_{AC}, full load: Neutral

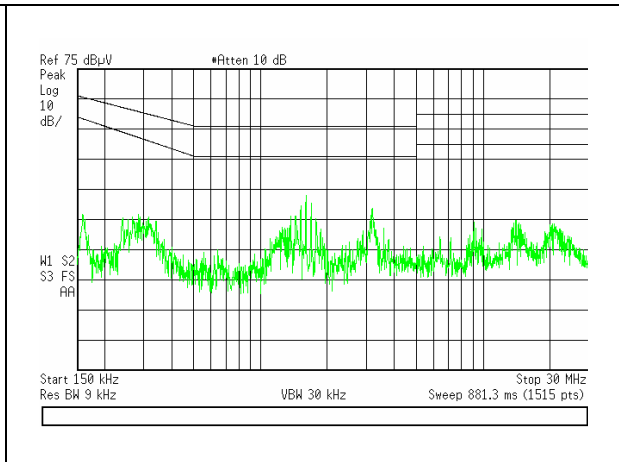
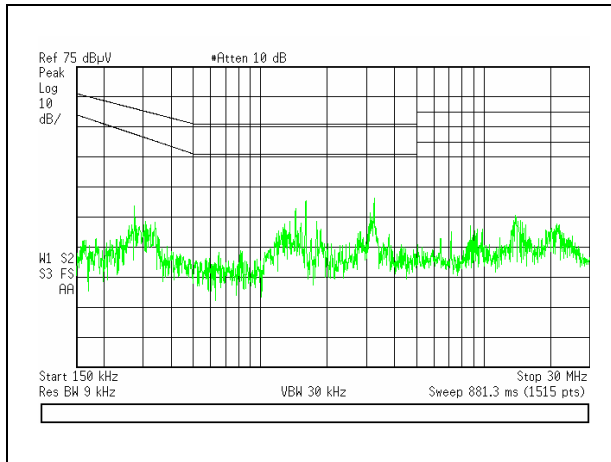

Figure 18. Buck converter: conducted emission @ 230V_{AC}, full load: Phase

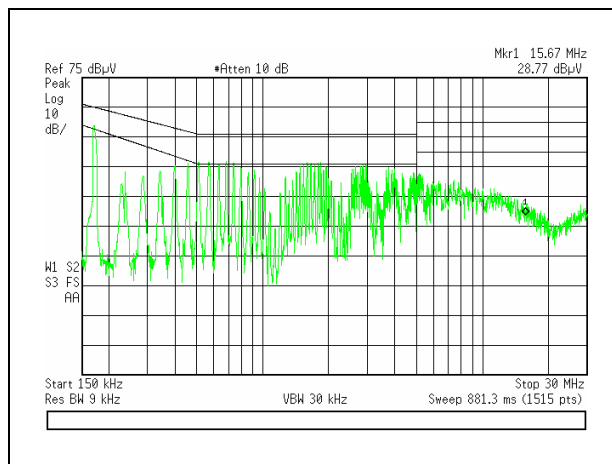
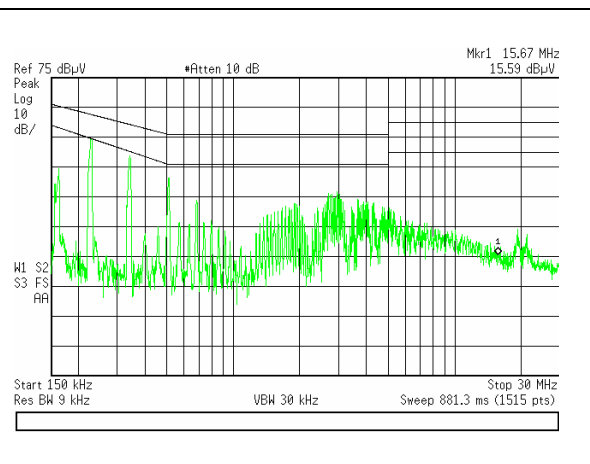

Figure 19. Buck converter: conducted emission @ 230V_{AC}, full load: Neutral



2.3 Higher output power

Higher output power levels could be required in some applications. Typical values are 50mA on the 12V output and 100mA on the -5V output, as listed in [Table 5](#).

Table 5. Higher output power requirements

AC input voltage V _{IN}	185÷265V _{AC}
Outputs	V _{out1} =12V; I _{out1} =50mA
	V _{out2} =-5V; I _{out2} =100mA
Total output power	1.1W

The proposed Buck converters can provide such current values adjusting the value of the bleeder resistor, R1. In fact, in order to maintain the regulation when out1 is in open load condition, (2) has to be verified:

$$\frac{V_{R1}}{R1} > I_{out2} + I_{Dz2} \quad (2)$$

Since I_{out2} = 100mA, we can set V_{R1}/R1 = 120mA, resulting in:

V_{R1}/R1 ≈ 12/R1 = 120mA, therefore R1 = 100Ω for schematic A (see [Figure 7](#));

V_{R1}/R1 ≈ 7/R1 = 120mA, therefore R1 = 56Ω for schematic B (see [Figure 8](#)).

Thus, the R1 value is lower than in the previous case. Of course, this results in higher power dissipation across the bleeder.

In [Table 6](#), the part list of the modified components is given.

Table 6. Schematics A and B part list modification

Reference	Value	Part type
R1	100Ω 2W (schematic A) 56Ω 2W (schematic B)	Resistor (bleeder)
C6	47μF, 25V	Electrolytic capacitor
C7	47μF, 25V	Electrolytic capacitor
Dz1	12V (schematic B)	Zener diode
R2	0Ω (schematic B)	
L	820 μH	Radial inductor

The line regulation of the two Buck converters is shown in [Figure 20.](#), [Figure 21.](#), the load regulation in [Figure 22.](#), [Figure 23.](#), [Figure 24.](#) and [Figure 25.](#) the efficiency in [Figure 26.](#)

Figure 20. Line regulation @full load (Buck converter, schematic A)

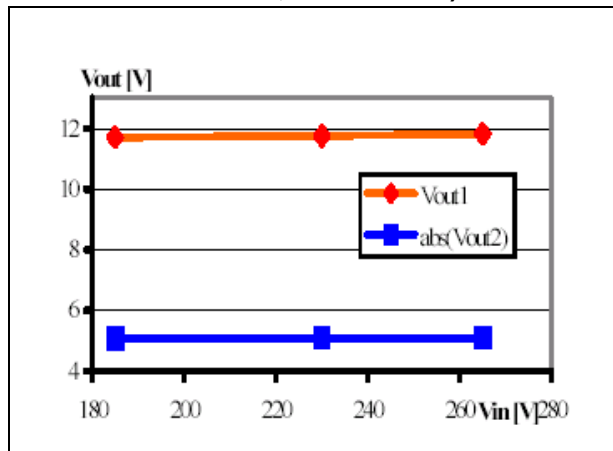

Figure 21. Line regulation @full load (Buck converter, schematic B)

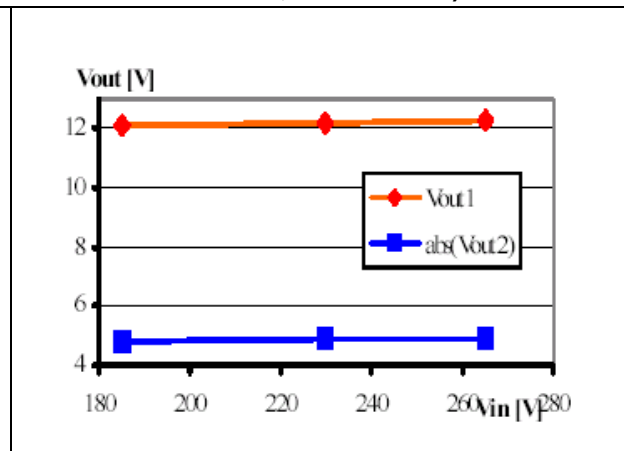

Figure 22. Out1 load regulation @ Iout2 = 0 (Buck converter, schematic A)

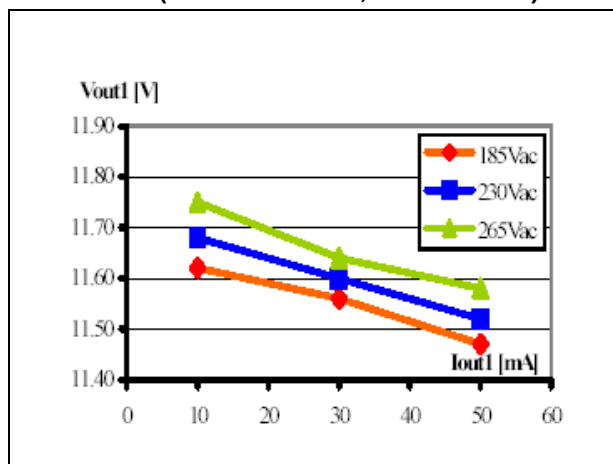

Figure 23. Out2 load regulation @ Iout1 = 20mA (Buck converter, schematic A)

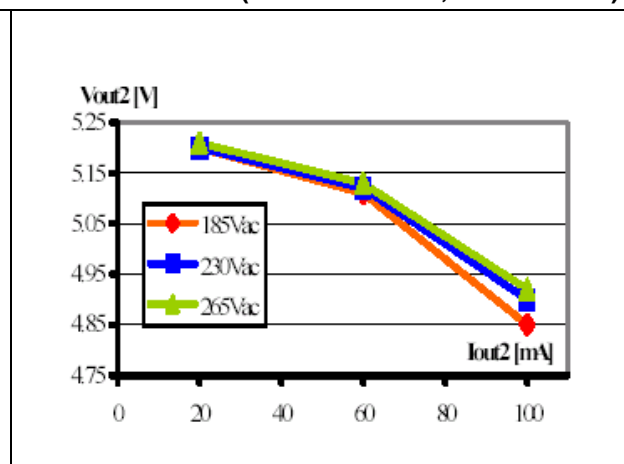

Figure 24. Out1 load regulation @ Iout2 = 0 (Buck converter, schematic B)

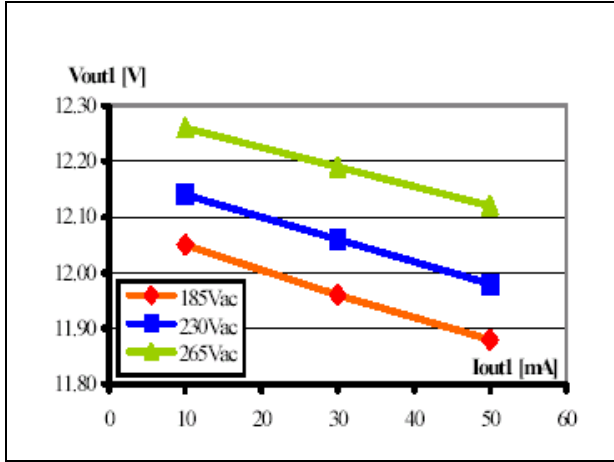

Figure 25. Out2 load regulation @ Iout1 = 20mA (Buck converter, schematic B)

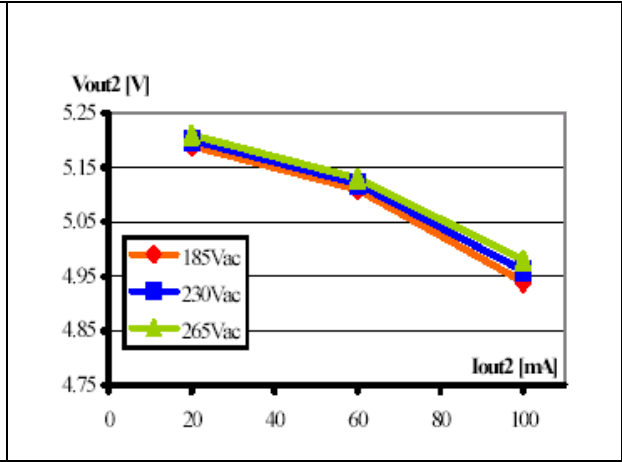
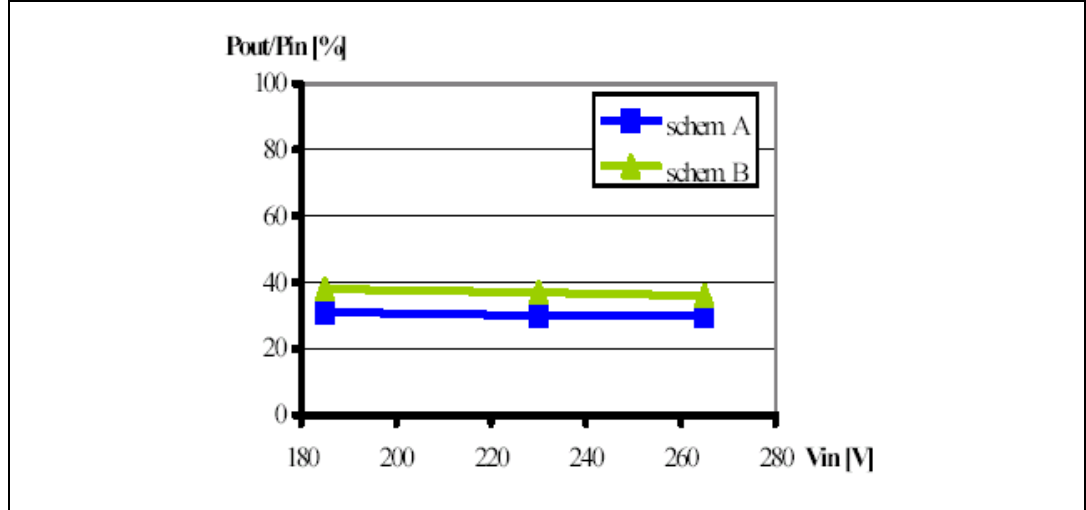

Figure 26. Efficiency vs Vin



If a Capacitive network were used to supply such output power, it would require quite big and expensive capacitors.

In fact, referring to figure 1, the value of the output capacitors, C4 and C6, can be calculated using equation (3):

$$C_{out} = \frac{(I_{out} + I_{Dz}) \cdot T}{\Delta V_{OUTmax}} \tag{3}$$

where I_{Dz} is the current flowing through D_{z1} or D_{z2} in the circuit of *Figure 1.*, and T is the discharging time of the capacitor.

Fixing $f = 60\text{Hz}$ for the input voltage frequency and 5% for the maximum output voltage ripple, (3) becomes:

$$C_{out} \cong \frac{I_{out} + I_{Dz}}{f \cdot \Delta V_{OUTmax}} = \frac{I_{out} + I_{Dz}}{f \cdot 5\%V_{OUT}} \tag{4}$$

Assuming $I_{Dz} = 5\text{mA}$, (4) gives $C4 = C_{out1} > 1500\mu\text{F}$ for $I_{out1} = 50\text{mA}$, $V_{out1} = 12\text{V}$, and $C6 = C_{out2} > 7000\mu\text{F}$ for $I_{out2} = 100\text{mA}$, $V_{out2} = -5\text{V}$.

2.4 Efficiency comparison

The power loss on the bleeder has the main impact on the efficiency η of the modified Buck converters. In fact, the output power and the power loss on the zener diode, D_{z2} , are the same for both converters.

The comparison between the circuits of [Figure 7](#). and [Figure 8](#). has shown that:

$$\eta_B > \eta_A \quad \text{if} \quad I_{out2} > \frac{1}{1 - \frac{V_{R1B}}{V_{R1A}}} \cdot I_{out1} - I_{Dz2} \quad (5)$$

where:

$\eta_B > \eta_A$ = efficiency of the schematic A (B) Buck converter;

V_{R1A} (V_{R1B}) = voltage across the bleeder resistor R1 in the schematic A (B);

I_{Dz2} = current across D_{z2} .

Assuming $I_{Dz2} = 30\text{mA}$, $V_{R1A} = 12\text{V}$, $V_{R1B} = 7\text{V}$, equation (5) becomes:

$$\eta_B > \eta_A \quad \text{if} \quad I_{out2} > 2.4I_{out1} - 30 \quad (6)$$

where I_{out1} and I_{out2} are expressed in mA.

The efficiency comparison between the two converters, based on (6), is shown in [Figure 27](#).

In conclusion, the schematic B (in figure 8) can be used in both cases, although in the lower power case it features a slightly lower efficiency (3÷4%).

Figure 27. Efficiency comparison between schematics A and B for $I_{Dz2} = 30\text{mA}$

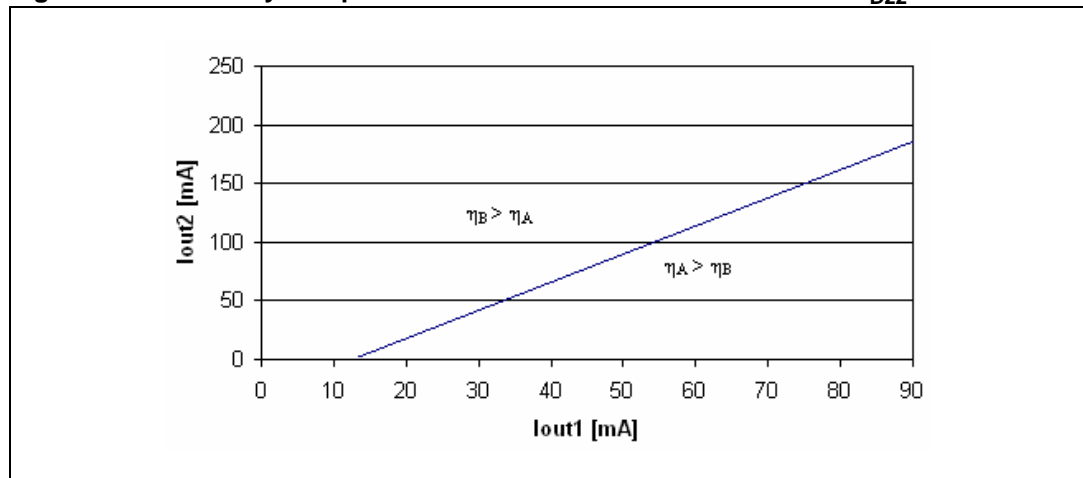

2.5 Different output voltages

If a lower value of the output V_{out1} is desired, the value of the zener diode $Dz1$ has to be changed. Since $V_{out1} + V_{Dz2}$ is lower than 16V , the biasing network of the VIPer12A in the

schematic A will also be modified, in order to ensure the start-up of the device. In this way the only difference between the two schematics will be in the reference of the output voltages and in the values of the zener diodes, as can be seen from [Figure 28.](#) and [Figure 29.](#)

Figure 28. Schematic A modifications for $4V < V_{out1} < 11V$ ($V_{out2} \cong 5V$)

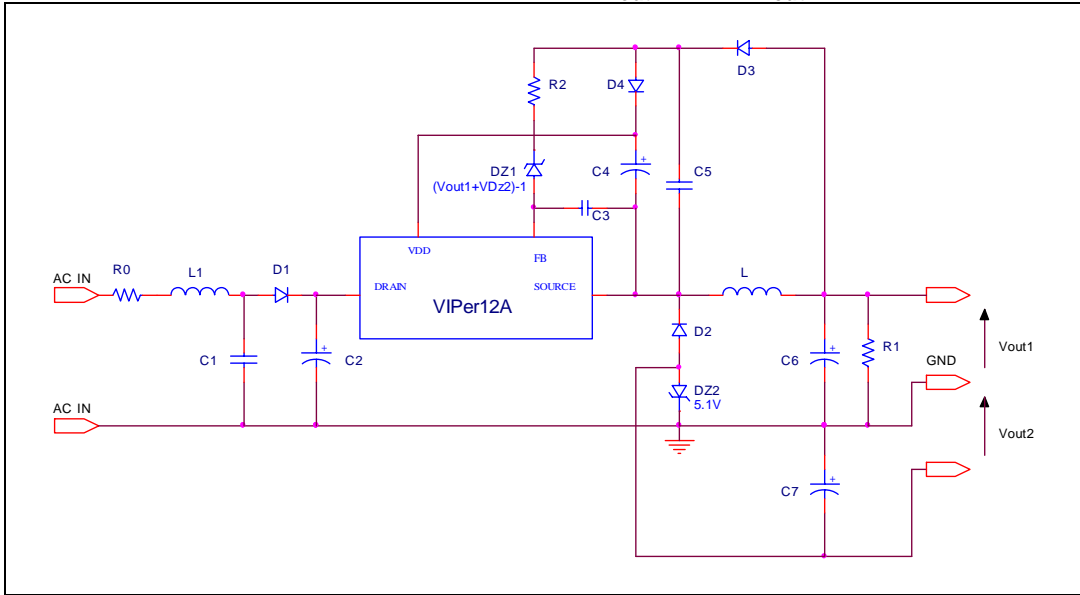
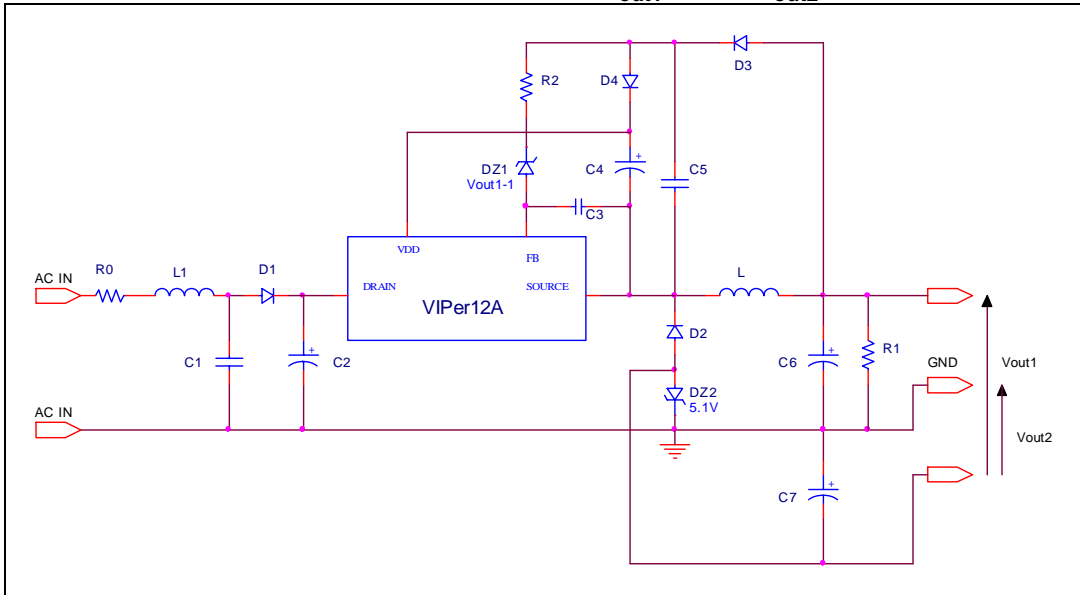

Figure 29. Schematic B modifications for $9V < V_{out1} < 16V$ ($V_{out2} \cong 5V$)



In order to make the VIPer12A properly supplied by the biasing network of the [Figure 28.](#) and [Figure 29.](#), the formulas (7) and (8) have to be satisfied:

$$\text{Schematic A (Figure 28.)} \quad 9V < V_{out1} + V_{DZ2} < 16V \quad (7)$$

This means that, if V_{out2} is fixed at 5V, the allowed range of V_{out1} in the schematic A will be about 4V ÷ 11V; if not, these limits will be moved together upwards or downwards depending on the value of V_{Dz2} ($\cong V_{out2}$).

$$\text{Schematic B (Figure 29.)} \quad 9V < V_{out1} < 16V \quad (8)$$

Thus, for the schematic B the minimum allowable value of V_{out1} is 9V, quite apart from the value of V_{out2} .

The resistor R2 is optional and can be experimentally fixed between 0 and 1k Ω if a tune of the output voltage is needed.

3 Conclusions

Two versions of a very low cost Buck converter based on VIPer12A have been proposed and compared with a Capacitive converter in terms of output voltage regulation, input power consumption, EMI and efficiency, in the same output power conditions.

As a result of the analysis, it can be pointed out that:

- the efficiency of both the Buck converters is higher than the efficiency of the Capacitive network;
- the output capacitors needed in the Capacitive power supply are much bigger and expensive than those required in the Buck converters (1mF and 4.7mF vs 33 μ F);
- due to the switching operation of the Buck converter, an EMI input filter has to be inserted, as shown in figures 5 and 6;
- the Buck solution is less expensive than the Capacitive one, with a cost saving of about 10 ÷ 15%.

4 Revision history

Table 7. Document revision history

Date	Revision	Changes
26-Jan-2006	1	First issue

Information furnished is believed to be accurate and reliable. However, STMicroelectronics assumes no responsibility for the consequences of use of such information nor for any infringement of patents or other rights of third parties which may result from its use. No license is granted by implication or otherwise under any patent or patent rights of STMicroelectronics. Specifications mentioned in this publication are subject to change without notice. This publication supersedes and replaces all information previously supplied. STMicroelectronics products are not authorized for use as critical components in life support devices or systems without express written approval of STMicroelectronics.

The ST logo is a registered trademark of STMicroelectronics.
All other names are the property of their respective owners

© 2006 STMicroelectronics - All rights reserved

STMicroelectronics group of companies

Australia - Belgium - Brazil - Canada - China - Czech Republic - Finland - France - Germany - Hong Kong - India - Israel - Italy - Japan -
Malaysia - Malta - Morocco - Singapore - Spain - Sweden - Switzerland - United Kingdom - United States of America

www.st.com