

150 W inverter featuring L639x and STGD3HF60HD for 1-shunt based sinusoidal vector control and trapezoidal scalar control

Introduction

The 150 W inverter power stage board features the L639x and STGD3HF60HD for both field-oriented control (FOC) of permanent magnet synchronous motors (PMSM) and trapezoidal scalar control of brushless DC (BLDC) motors. Also referred to by the order code STEVAL-IHM032V1, this 3-phase inverter is designed to perform both the FOC of sinusoidal-shaped back-EMF PMSMs and trapezoidal control of BLDC motors with or without sensors, with nominal power up to 150 W. The flexible, open, high-performance design consists of a 3-phase inverter bridge based on:

- The STGD3HF60HD (4.5 A, 600 V) very fast IGBT in a DPAK package, with ultrafast recovery diode
- The L639x devices which are part of the latest high-voltage half bridge gate driver family featuring an integrated comparator for implementation of hardware protection (i.e. overcurrent, overtemperature, etc.)
- An embedded operational amplifier suitable for advanced current sensing

The system is specifically designed to achieve fast and accurate conditioning of the current feedback, thereby matching the requirements typical of high-end applications such as field oriented motor control. As an alternative to the STGD3HF60HD, the STD5N52U power MOSFET, STGD6NC60HD IGBT device may be used on the board without replacing the switch driving network.

The board is compatible with 110 and 230 Vac mains, and includes a power supply stage with the VIPer12AS-E (in flyback configuration) to generate the +15 V and +3.3 V supply voltage required by the application. Finally, the board can be interfaced with STM3210xx-EVAL (STM32 microcontroller demonstration board), STEVAL-IHM022V1 (high density dual motor control demonstration board based on the STM32F103ZE microcontroller), and with STEVAL-IHM033V1 (control stage based on STM32F100 microcontroller suitable for motor control), through a dedicated connector.

Figure 1. STEVAL-IHM032V1 demonstration board

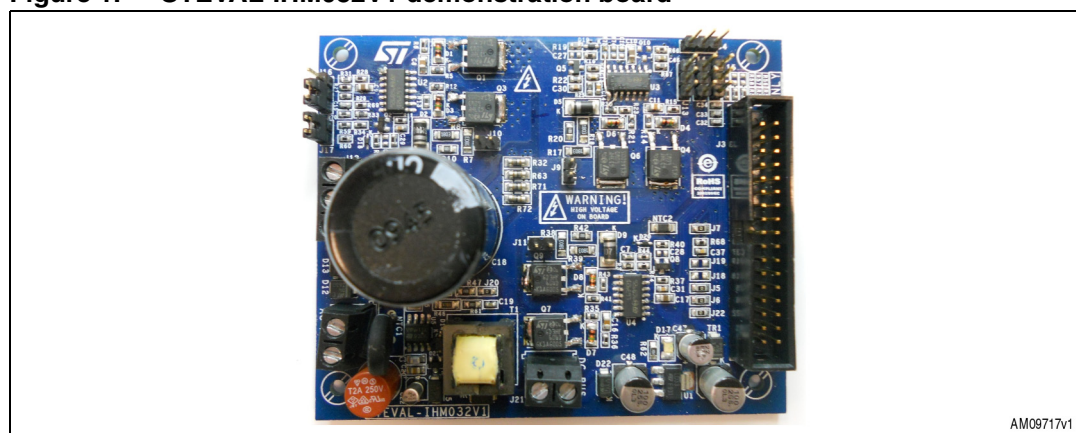

Contents

1	Main features	6
1.1	Target application	6
2	System architecture	7
3	Safety and operating instructions	8
3.1	General	8
3.2	Intended use of the demonstration board	8
3.3	Installing the demonstration board	8
3.4	Electronic connections	8
3.5	Operating the demonstration board	9
4	L6392 characteristics	10
4.1	Main features	10
4.2	Block diagram	10
5	L6391 characteristics	11
5.1	Main features	11
5.2	Block diagram	11
6	STGD3HF60HD characteristics	12
7	Electrical characteristics of the board	13
8	Board architecture	14
8.1	Power supply	14
8.2	Gate driving	14
8.3	Hardware overcurrent protection	15
8.4	Amplifying network for current measurement	15
8.5	Temperature feedback	15
8.6	BEMF zero crossing detecting network	15
8.7	BLDC current limitation/regulation network	15
8.8	Overcurrent boost network	15

8.9	Hall sensor/quadrature encoder inputs	16
9	STEVAL-IHM032V1 schematic diagrams	17
9.1	Gate driving circuit	20
9.2	Overcurrent protection	20
9.3	Overcurrent boost	21
9.4	Current sensing amplification network	21
9.5	Jumper configuration	22
9.5.1	Current sensing network jumper settings	22
9.5.2	Bus voltage divider jumper setting	23
9.5.3	Position feedback jumper setting	23
9.5.4	BEMF zero crossing detection network enabling	24
9.5.5	Motor control connector extra features enabling	24
9.6	Motor control connector J3 pinout	24
10	Using the STEVAL-IHM032V1 with the STM32 FOC firmware library .	26
10.1	Environmental considerations	26
10.2	Hardware requirements	27
10.3	Software requirements	27
10.4	STM32 FOC firmware library v3.0 customization	27
11	Bill of material	29
12	References	32
13	Revision history	33

List of tables

Table 1.	Absolute maximum ratings	12
Table 2.	Board electrical characteristics	13
Table 3.	“OC Boost” signal activation logic and overcurrent threshold	21
Table 4.	Motor control connector J3 pin assignment	25
Table 5.	STEVAL-IHM032v1 motor control workbench parameters	27
Table 6.	Bill of material	29
Table 7.	Document revision history	33

List of figures

Figure 1.	STEVAL-IHM032V1 demonstration board	1
Figure 2.	Motor control system architecture	7
Figure 3.	L6392 block diagram	10
Figure 4.	L6391 block diagram	11
Figure 5.	STGD3HF60HD	12
Figure 6.	STEVAL-IHM032V1 block diagram	14
Figure 7.	Inverter schematic	17
Figure 8.	Power supply schematic	18
Figure 9.	Sensor inputs, BEMF detecting network, motor control connector	19
Figure 10.	Detailed gate driving circuit	20
Figure 11.	Current sensing amplifying network	21
Figure 12.	Motor control connector J3 (top view)	24

1 Main features

The STEVAL-IHM032V1 150 W inverter power stage board has the following characteristics:

- Compact size
- Wide range input voltage
- Maximum power up to 150 W at 230 Vac input
- The STGD3HF60HD 4.5 A, 600 V very fast IGBT
- Compatibility with other power switches in DPAK packages (the STD5N52U, STGD6NC60HD, for example)
- AC or DC bus voltage power supply connectors
- Connector for interfacing with the STM3210xx-EVAL board, STEVAL-IHM022V1, and STEVAL-IHM033V1 with alternate functions (current reference, current limitation/regulation, method selection, current boost)
- Efficient DC/DC power supply (15 V, 3.3 V)
- Suitable both for sinusoidal FOC and trapezoidal BLDC drive
- Single-shunt current reading topology with fast operational amplifier (with offset insertion for bipolar currents)
- Hardware overcurrent protection with boost capabilities
- Temperature sensor
- BEMF detecting network for BLDC drive
- Current regulation/limitation network for BLDC drive
- Hall sensor/quadrature encoder inputs

1.1 Target application

- Dishwasher pumps
- Refrigerator compressors
- Fans

2 System architecture

A generic motor control system can be schematized as the arrangement of four main blocks ([Figure 2](#)).

- Control block: its main tasks are to accept user command and motor drive configuration parameters, and to provide digital signals to implement the appropriate motor driving strategy
- Power block: it performs the power conversion from the DC bus, transferring it to the motor by means of a 3-phase inverter topology
- The motor: the STEVAL-IHM032V1 board can drive both PMSM and BLDC motors
- Power supply block: it can accept input voltages of 86 to 260 Vac and provides the appropriate levels to supply both the control block and power block devices.

Figure 2. Motor control system architecture

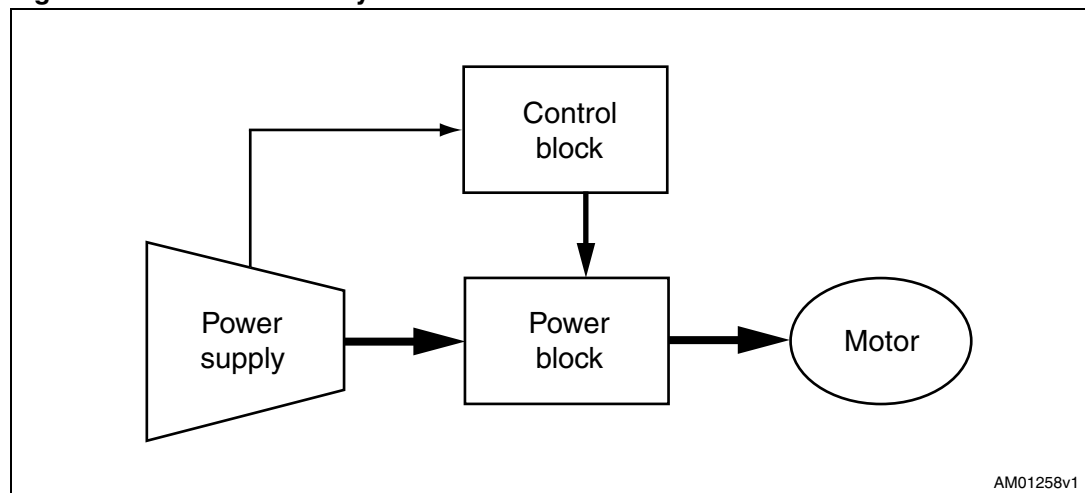

Of the above motor control system architecture, the STEVAL-IHM032V1 includes the power supply and power hardware blocks.

The power block, based on the high voltage gate driver L639x and very fast IGBT STGD3HF60HD, converts the signals coming from the control block into power signals capable of correctly driving the 3-phase inverter, and therefore the motor.

The power supply can be fed with 110 or 230 Vac mains, and the maximum allowed input power is 150 W at 230 Vac (refer to [Section 7](#)).

In the control block, a J3 connector is mounted on both the STEVAL-IHM032V1 and the STM3210xx-EVAL, STEVAL-IHM022V1, and STEVAL-IHM033V1, which allows the STM32 microcontroller demonstration board to be used as a hardware platform for development. The “STM32 FOC firmware libraries v3.0” is ready to be used in conjunction with the STM32 MC Workbench as a software platform for the sensorless control of PMSMs (see [Section 10](#)).

The required STM32 motor control workbench data is reported in [Table 5](#).

3 Safety and operating instructions

3.1 General

Warning: During assembly and operation, the STEVAL-IHM032V1 demonstration board poses several inherent hazards, including bare wires, moving or rotating parts, and hot surfaces. Serious personal injury and damage to property may occur if the kit or its components are used or installed incorrectly.

All operations involving transportation, installation, and use, as well as maintenance, should be performed by skilled technical personnel (applicable national accident prevention rules must be observed). The term “skilled technical personnel” refers to suitably-qualified people who are familiar with the installation, use and maintenance of electronic power systems.

3.2 Intended use of the demonstration board

The STEVAL-IHM032V1 demonstration board is designed for demonstration purposes only, and must not be used for electrical installations or machinery. Technical data and information concerning the power supply conditions are detailed in the documentation and should be strictly observed.

3.3 Installing the demonstration board

- The installation and cooling of the demonstration board must be in accordance with the specifications and target application.
- The motor drive converters must be protected against excessive strain. In particular, components should not be bent or isolating distances altered during transportation or handling.
- No contact must be made with other electronic components and contacts.
- The board contains electrostatically-sensitive components that are prone to damage if used incorrectly. Do not mechanically damage or destroy the electrical components (potential health risks).

3.4 Electronic connections

Applicable national accident prevention rules must be followed when working on the main power supply with a motor drive. The electrical installation must be completed in accordance with the appropriate requirements (for example, cross-sectional areas of conductors, fusing, PE connections, etc.).

3.5 Operating the demonstration board

A system architecture that supplies power to the STEVAL-IHM032V1 demonstration board must be equipped with additional control and protective devices in accordance with the applicable safety requirements (i.e., compliance with technical equipment and accident prevention rules).

Warning: Do not touch the demonstration board after it has been disconnected from the voltage supply as several parts and power terminals containing possibly-energized capacitors need time to discharge.

4 L6392 characteristics

4.1 Main features

- High voltage rail up to 600 V
- dV/dt immunity ± 50 V/nsec in full temperature range
- Driver current capability:
 - 290 mA source
 - 430 mA sink
- Switching times 75/35 nsec rise/fall with 1 nF load
- 3.3 V, 5 V TTL/CMOS inputs with hysteresis
- Integrated bootstrap diode
- Operational amplifier for advanced current sensing
- Adjustable dead-time
- Interlocking function

4.2 Block diagram

Figure 3 shows the block diagram of the L6392 device.

Figure 3. L6392 block diagram

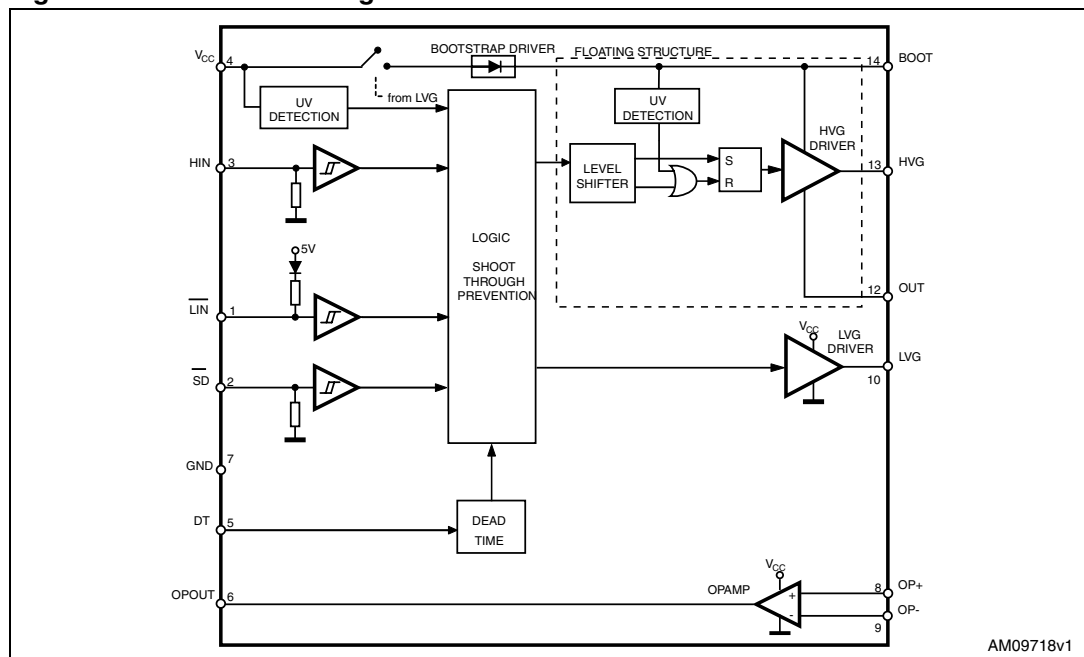

5 L6391 characteristics

5.1 Main features

- High voltage rail up to 600 V
- dV/dt immunity ± 50 V/nsec in full temperature range
- Driver current capability:
 - 290 mA source,
 - 430 mA sink
- Switching times 75/35 nsec rise/fall with 1 nF load
- 3.3 V, 5 V TTL/CMOS inputs with hysteresis
- Integrated bootstrap diode
- Comparator for fault protections
- Smart shutdown function
- Adjustable dead-time
- Interlocking function
- Effective fault protection

5.2 Block diagram

Figure 4 shows the block diagram of the L6391 device.

Figure 4. L6391 block diagram

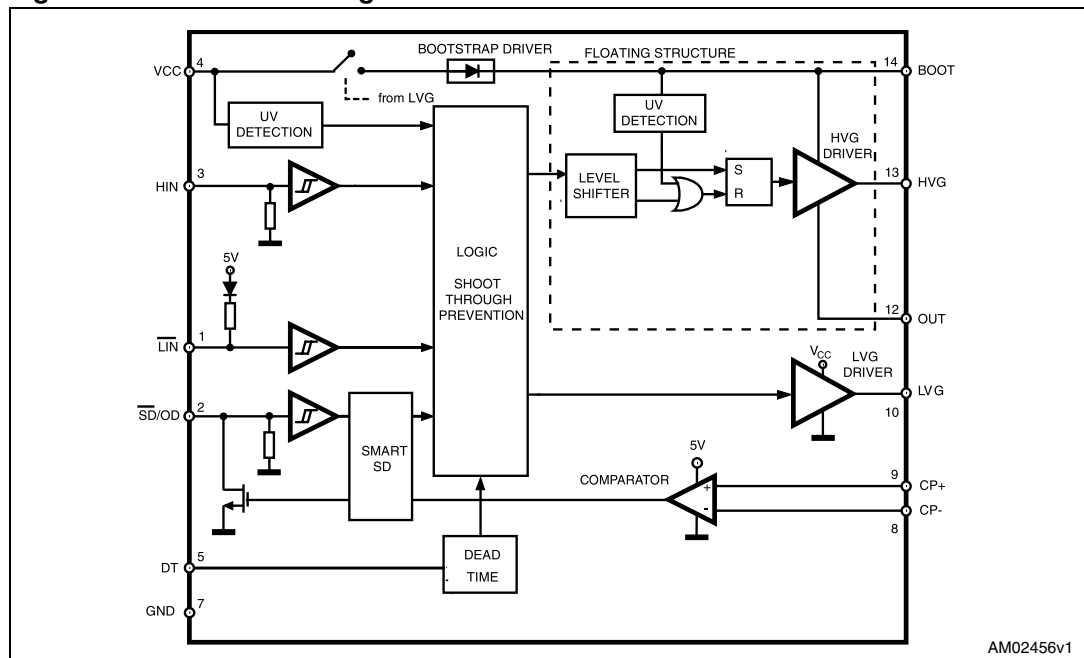

6 STGD3HF60HD characteristics

The STGD3HF60HD is based on a new advanced planar technology concept to yield an IGBT with more stable switching performance (E_{off}) versus temperature, as well as lower conduction losses.

Figure 5. STGD3HF60HD

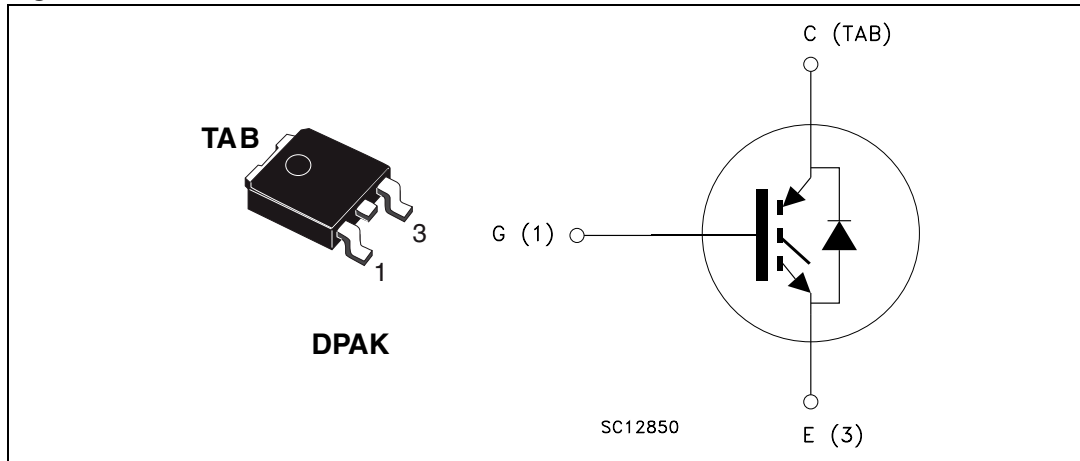

- $V_{CES} = 600 \text{ V}$
- $V_{CE(sat)} < 2.95 \text{ V}$
- $I_C @ 100 \text{ }^\circ\text{C} = 4.5 \text{ A}$

Table 1. Absolute maximum ratings

Symbol	Parameter	Value	Unit
V_{CES}	Collector-emitter voltage ($V_{GE} = 0$)	600	V
$I_C^{(1)}$	Continuous collector current at $T_C = 25 \text{ }^\circ\text{C}$	7.5	A
$I_C^{(1)}$	Continuous collector current at $T_C = 100 \text{ }^\circ\text{C}$	4.5	A
$I_{CL}^{(2)}$	Turn-off latching current	18	A
$I_{CP}^{(3)}$	Pulsed collector current	18	A
V_{GE}	Gate-emitter voltage	± 20	V
I_F	Diode RMS forward current at $T_C = 25 \text{ }^\circ\text{C}$	10	A
I_{FSM}	Surge non repetitive forward current $t_p=10 \text{ ms}$ sinusoidal	25	A
P_{TOT}	Total dissipation at $T_C = 25 \text{ }^\circ\text{C}$	38	W
T_j	Operating junction temperature	- 55 to 150	$^\circ\text{C}$

1. Calculated according to the iterative formula:

$$I_C(T_C) = \frac{T_{j(max)} - T_C}{R_{thj-c} \times V_{CE(sat)(max)}(T_{j(max)}, I_C(T_C))}$$

- $V_{clamp} = 80\%(V_{CES})$, $T_j = 150 \text{ }^\circ\text{C}$, $R_G = 10 \text{ } \Omega$, $V_{GE} = 15 \text{ V}$.
- Pulse width limited by maximum junction temperature and turn-off within RBSOA.

Note: Stresses above the limits shown in [Table 1](#) may cause permanent damage to the device.

7 Electrical characteristics of the board

Board power is intended to be supplied by an alternate current power supply through connector J2 (AC mains) or optionally by a direct current power supply through connector J21 (DC Bus), in which case it is required to respect the correct polarity.

Stresses above the limits shown in [Table 2](#) may cause permanent damage to the devices present inside the board. These are stress ratings only and functional operation of the device under these conditions is not implied. Exposure to maximum rating conditions for extended periods may affect device reliability.

A bias current measurement may be useful to check the working status of the board. If the measured value is considerably higher than the typical value, some damage has occurred to the board. Supply the board using a 40 V power supply connected to J21, respecting the polarity. When the board is properly supplied, LED D17 is turned on.

Table 2. Board electrical characteristics

Board parameters	STEVAL-IHM032V1		Unit
	Min.	Max.	
AC mains - J2	30	270	Vrms
DC bus – J21	40	380	V
40 V bias current (typical)	15	16	mA

8 Board architecture

The STEVAL-IHM032V1 can be schematized as shown in [Figure 6](#).

Figure 6. STEVAL-IHM032V1 block diagram

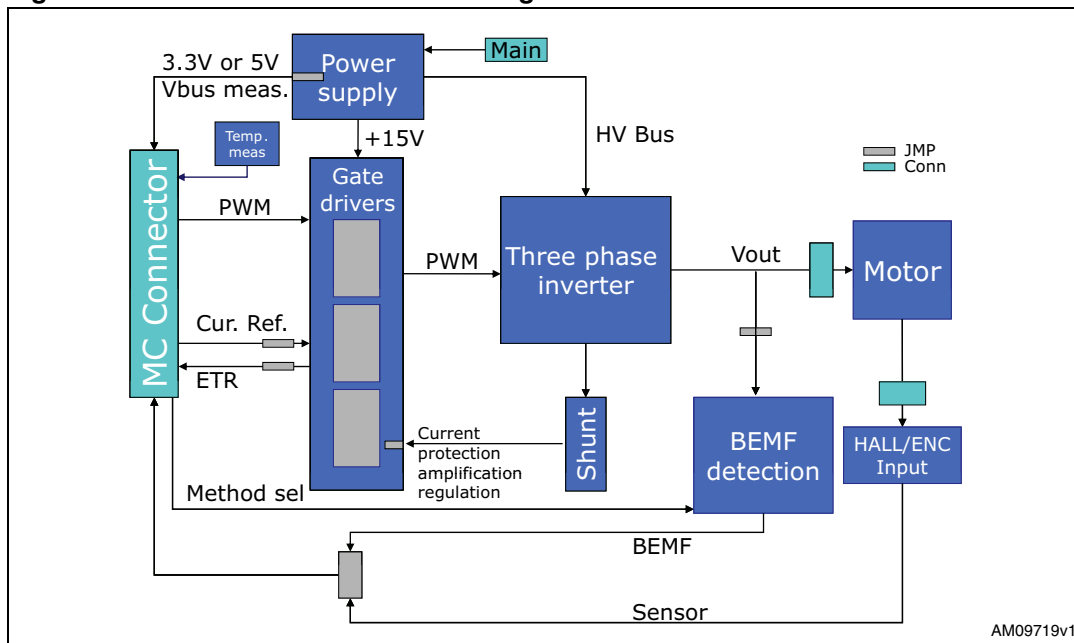

8.1 Power supply

The power supply can address an AC input voltage (J2) ranging from 30 Vac up to 270 Vac. The alternating current input is rectified by a diode bridge and a bulk capacitor to generate a direct current bus voltage approximately equal to $\sqrt{2}$ Vac (neglecting the voltage drop across the diodes and the bus voltage ripple). A VIPer12AS-E is then used in a flyback converter configuration to generate the +15 V supply voltage of the gate drivers and to supply the low drop voltage regulator (LD1117XX33) to generate the 3.3 V used as the V_{dd} microcontroller reference voltage. It is possible also to provide the 3.3 V supply voltage to the control board via motor control connector J3.

It is possible to modify the power supply stage to provide 5 V, to the control stage, instead of 3.3 V. To do this, it is required to change:

- the T1 transformer ratio should be equal to 2.22 (Magnetica code: 2092.0001)
- the U1 with LD1117S50TR

8.2 Gate driving

As already mentioned, gate driving of the switches is performed by the latest of the L639x family of devices. Refer to [Section 9.1](#) for detailed information on the gate driving circuit.

8.3 Hardware overcurrent protection

The hardware overcurrent protection is implemented using the fast shutdown feature of U3 (L6391).

A fault signal is also fed back to the J3 connector if an overcurrent event is detected.

See [Section 9.2](#) for more detailed information on hardware current protection.

8.4 Amplifying network for current measurement

The voltages across the shunt resistor are amplified by Aop amplification gains to correctly condition the current feedback signals and optimize the output voltage range for a given phase current range and A/D converter input dynamics. Refer to [Section 9.4](#) for more detailed information on how to dimension the op amp conditioning network depending on needs.

To implement the current measurement network, the operational amplifier present in U2 (L6392D) is used.

8.5 Temperature feedback

Temperature feedback is performed by way of an NTC. It enables monitoring of the power stage temperature so as to prevent any damage to the inverter caused by overtemperature.

8.6 BEMF zero crossing detecting network

The BEMF detection network allows the following strategies of BEMF sampling:

- BEMF sampling during OFF time (ST patented method)
- BEMF sampling during ON time
- Dynamic method based on the duty cycle applied.

For more details see the STM8S three-phase BLDC software library v1.0 (UM0708).

8.7 BLDC current limitation/regulation network

The current regulation/regulation network is used to adapt the signal to perform the cycle-by-cycle current control in the BLDC drive. See the STM8S three-phase BLDC software library v1.0 (UM0708) for more details.

The operational amplifier present in U4 (L6392D), used as a comparator, is used to implement the current limitation/regulation network.

8.8 Overcurrent boost network

An overcurrent boost network is present on the STEVAL-IHM32V1 board, which allows, in run time, to temporarily raise the hardware overcurrent protection threshold. See [Section 9.3](#) for more details.

8.9 Hall sensor/quadrature encoder inputs

The board is easily configurable to run the motor using the Hall sensors or quadrature encoder as position/speed feedback changing the jumpers J13, J14, and J15 and connecting the sensors signals to connector J4.

Note: The Hall sensors or quadrature encoder sensor is not power supplied by STEVAL-IHM032V1.

Note: The default configuration is intended for push-pull sensors. The R53, R54, and R55 resistors are used to limit the current injected into the microcontroller if the sensor high voltage is above $V_{dd-micro}$. The maximum current injected should be less than the maximum present in the microcontroller datasheet.

Note: If the sensor has open drain outputs, it is possible to mount the pull-up resistors R56, R57, and R58.

9 STEVAL-IHM032V1 schematic diagrams

Figure 7. Inverter schematic

STMicroelectronics and/or its licensors do not warrant the accuracy or completeness of this specification or any information contained therein. STMicroelectronics and/or its licensors do not warrant that this design will meet the specifications, will be suitable for your application or fit for any particular purpose, or will operate in an implementation. STMicroelectronics and/or its licensors do not warrant that the design is production worthy. You should completely validate and test your design implementation to confirm the system functionality for your application.

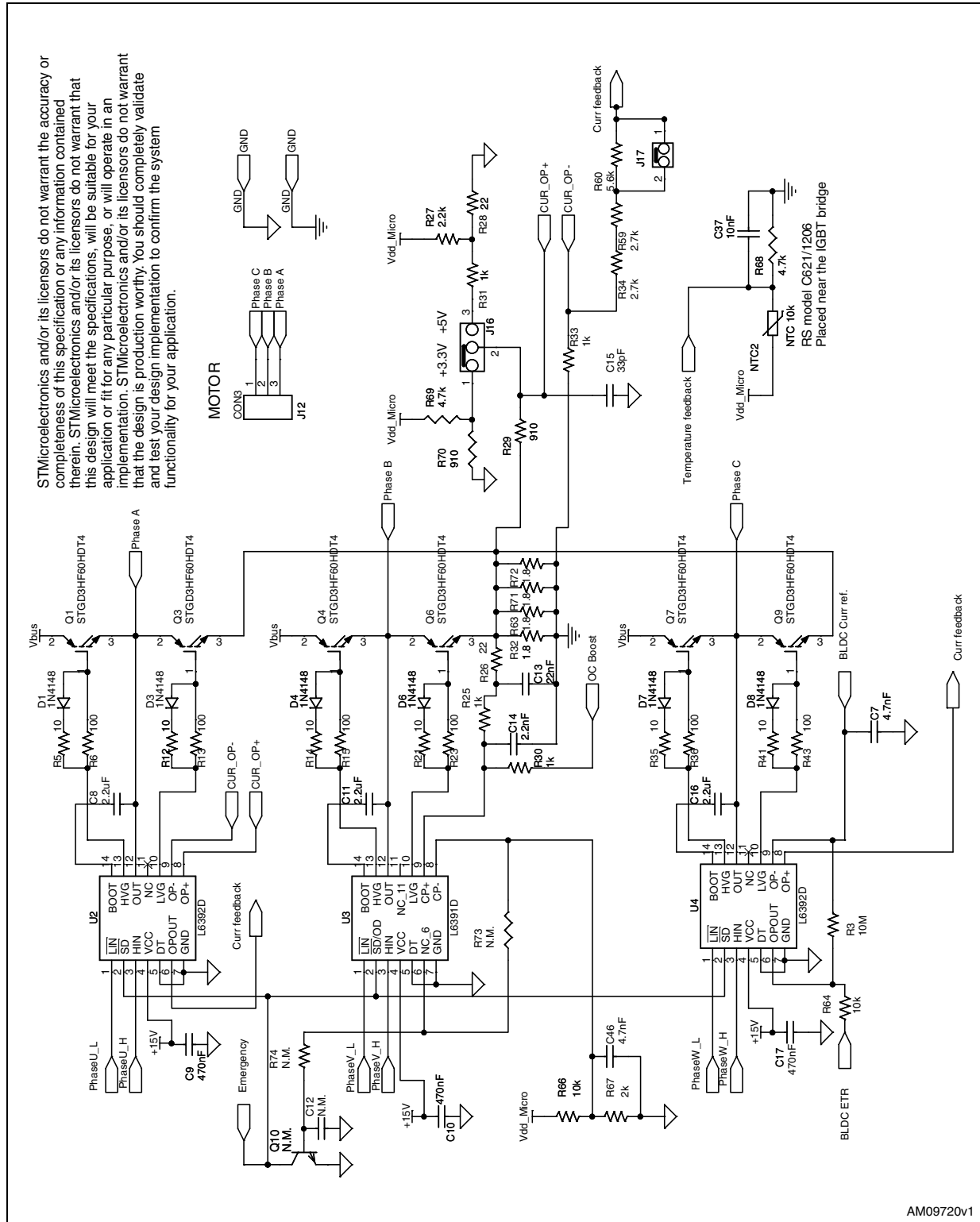

AM09720v1

Figure 8. Power supply schematic

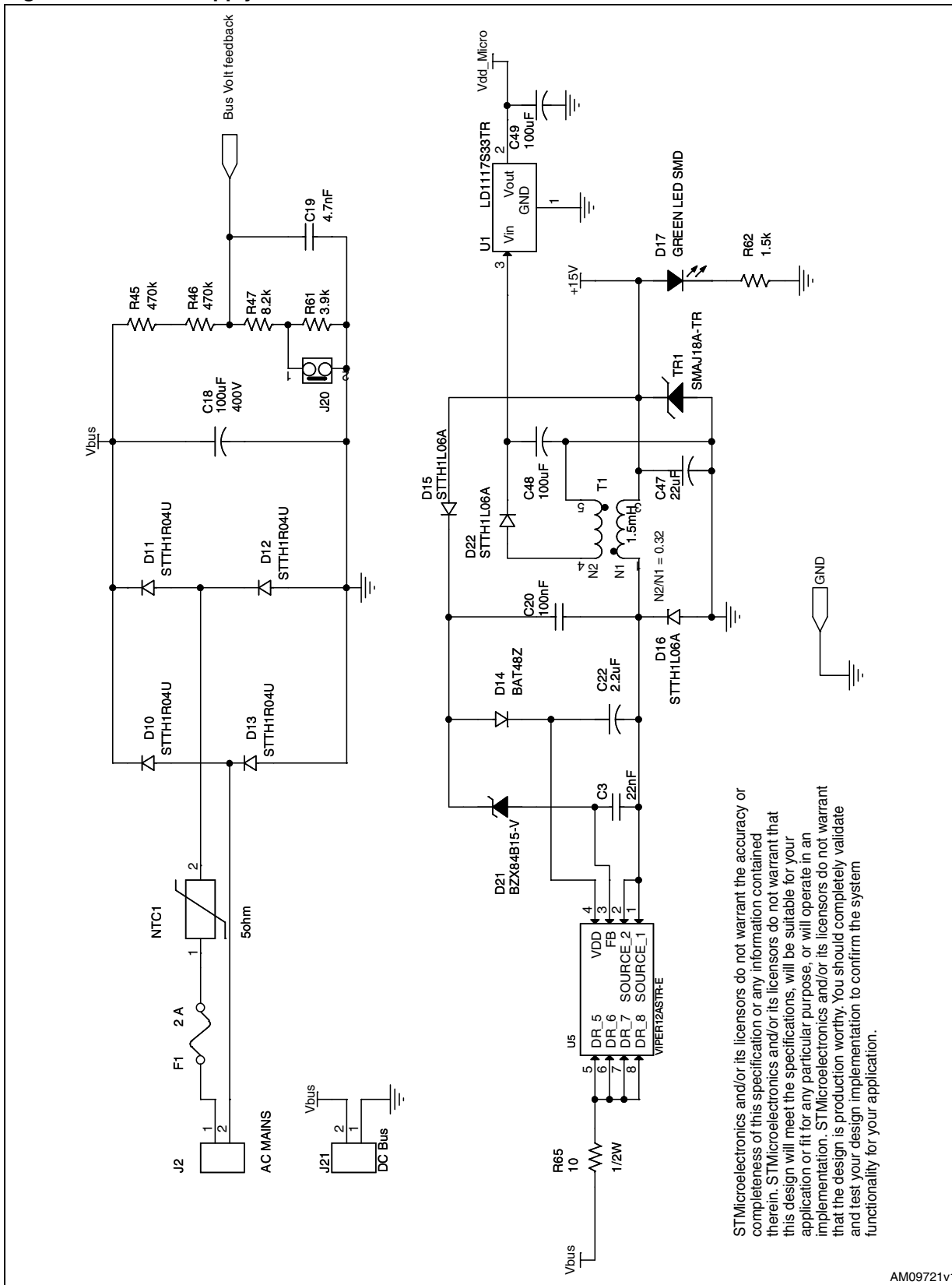

AM09721v1

Figure 9. Sensor inputs, BEMF detecting network, motor control connector

STMicroelectronics and/or its licensors do not warrant the accuracy or completeness of this specification or any information contained therein. STMicroelectronics and/or its licensors do not warrant that this design will meet the specifications, will be suitable for your application or fit for any particular purpose, or will operate in an implementation. STMicroelectronics and/or its licensors do not warrant that the design is production worthy. You should completely validate and test your design implementation to confirm the system functionality for your application.

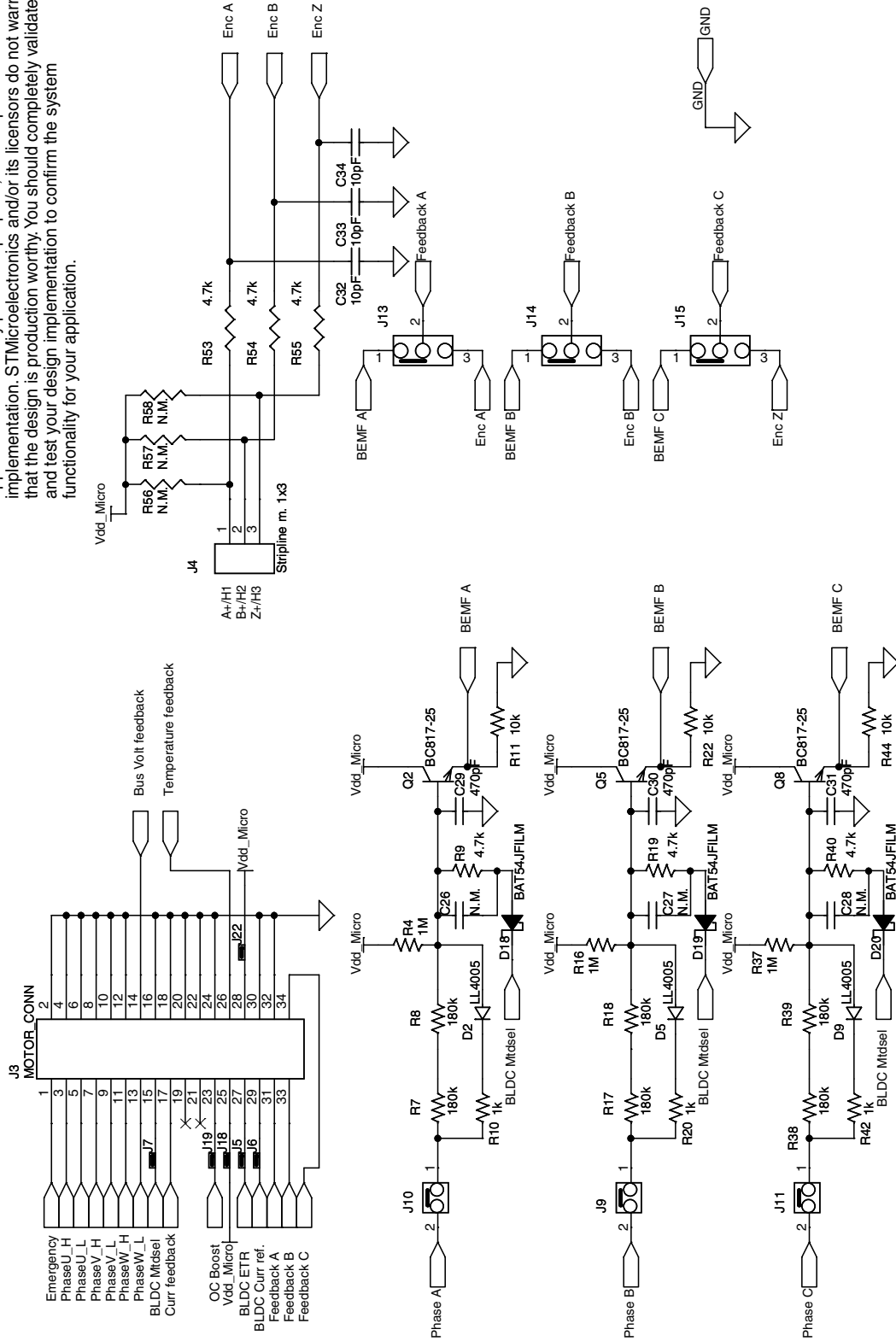

AM09722v1

9.1 Gate driving circuit

Figure 10 shows the circuit used to turn the power MOSFETs on and off.

Figure 10. Detailed gate driving circuit

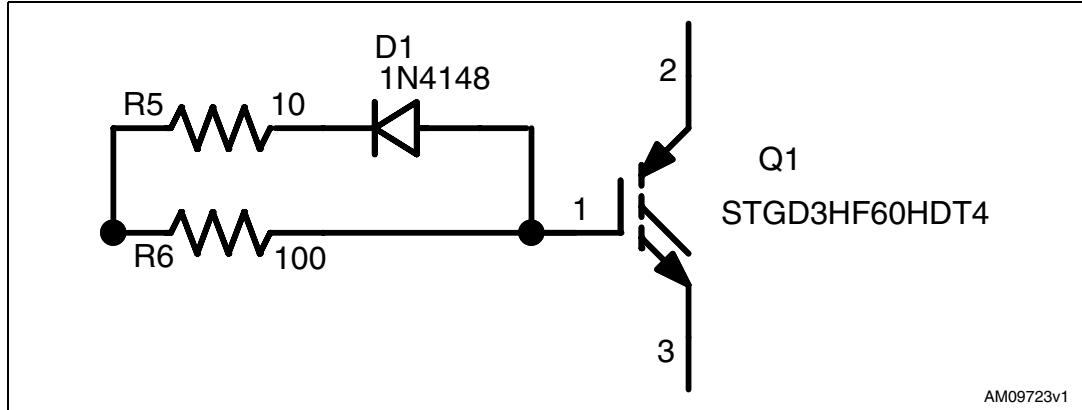

During the turn-on phase, the IGBT gate capacitances are charged through 100 Ω resistors while the turn-off is secured by the diode.

9.2 Overcurrent protection

Hardware overcurrent protection has been implemented on the board, taking advantage of the comparator integrated inside the L6391. The internal connection between the comparator output and the shutdown block makes the intervention time of the overcurrent protection extremely low, slightly above 100 ns.

Since the overcurrent protection acts as soon as the voltage on CP+ rises above Vref (approximately equal to $V_{dd_Micro}/6 = 3.3\text{ V}/6 = 0.55\text{ V}$), and given the default value of the shunt resistors (equal to $1.8/4 = 0.45\text{ }\Omega$), it follows that the default value for the maximum allowed current (ICP) is equal to:

Equation 1

$$I_{CP} = \frac{V_{Ref}}{R_{shunt}} \cong 1.22\text{ A}$$

If necessary, the overcurrent threshold can be modified changing R₆₆ and R₆₇ values according to the formula:

Equation 2

$$I_{CP} = \frac{1}{R_{shunt}} \left[V_{dd_Micro} \cdot \frac{R_{67}}{R_{66} + R_{67}} \right]$$

9.3 Overcurrent boost

Overcurrent boost can be requested by application, for instance, during the motor startup. The STEVAL-IHM032V1 includes an overcurrent boost feature, it is possible indeed to increase temporarily the hardware overcurrent protection threshold using the “OC Boost” signal present in the motor control connector J3 (pin 23). This signal is intended to be high impedance when not active while set to GND when active. The default values of the overcurrent threshold and the “OC Boost” signal activation logic is reported in [Table 3](#).

Table 3. “OC Boost” signal activation logic and overcurrent threshold

OC boost state	Physical state	Overcurrent threshold	Formula
Not active	High impedance	1.22 A (default)	$I_{CP} = \frac{1}{R_{shunt}} \left[V_{ddMicro} \cdot \frac{R_{67}}{R_{66} + R_{67}} \right]$
Active	Grounded	2.44 A (boost)	$I_{CP} = \frac{1}{R_{shunt}} \left[V_{ddMicro} \cdot \frac{R_{67}}{R_{66} + R_{67}} \right] \left[\frac{R_{30} + R_{25}}{R_{30}} \right]$

The overcurrent threshold during the boost can be modified changing the values of resistors R₂₅ and R₃₀ (see formulas in [Table 3](#)).

Note: It is possible also to implement an overcurrent protection disabling network if the value of R₃₀ is 0.

9.4 Current sensing amplification network

[Figure 11](#) shows the current sensing amplifying network.

Figure 11. Current sensing amplifying network

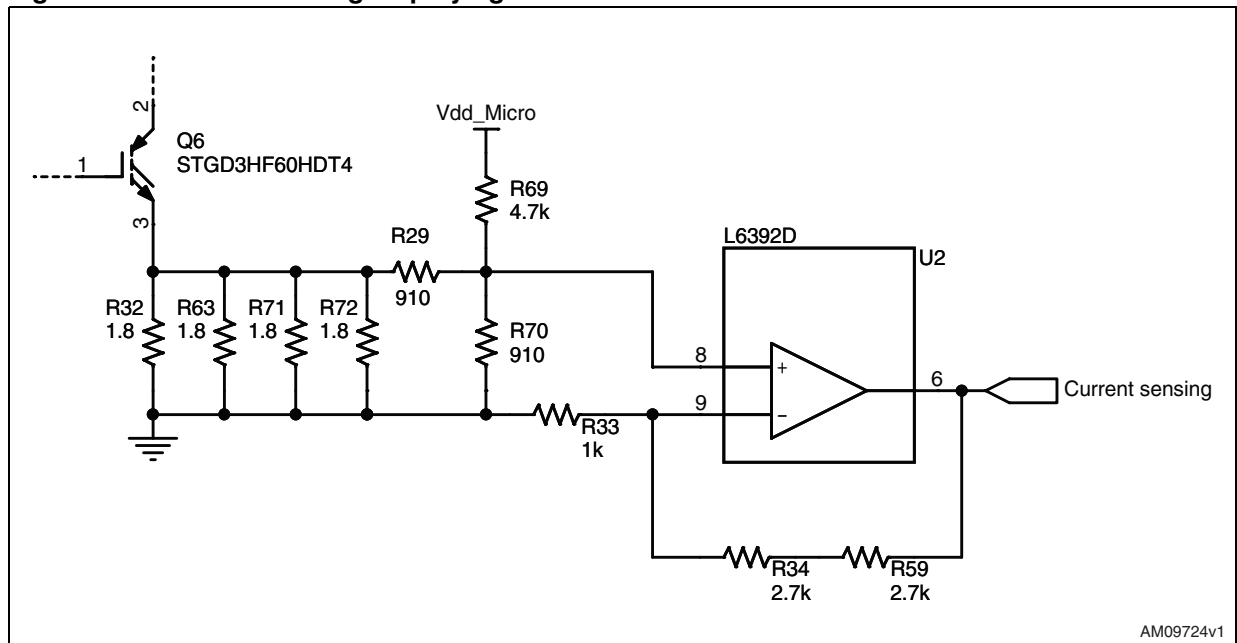

The voltage at node “current sensing” can be computed as the sum of a bias and a signal component, respectively equal to:

Equation 3

$$V_{\text{BIAS}} = V_{\text{ddMicro}} \cdot \frac{(R_{29} \parallel R_{70})}{R_{69} + R_{29} \parallel R_{70}} \cdot \left(1 + \frac{R_{34} + R_{59}}{R_{33}}\right)$$

Equation 4

$$V_{\text{SIGN}} = I \cdot R_{\text{Shunt}} \cdot \frac{(R_{69} \parallel R_{70})}{R_{29} + R_{69} \parallel R_{70}} \cdot \left(1 + \frac{R_{34} + R_{59}}{R_{33}}\right)$$

with the default values this gives:

- $V_{\text{BIAS}} = 1.86 \text{ V}$
- $V_{\text{SIGN}} = 2.91 \cdot R_{\text{Shunt}} \cdot I$

As such, the maximum current amplifiable without distortion is equal to:

Equation 5

$$I_{\text{MAX}} = \frac{3.3 - 1.86}{2.91 \cdot R_{\text{Shunt}}} = \frac{0.495}{R_{\text{Shunt}}} = 1.1 \text{ A}$$

Note that the I_{MAX} value can be modified by simply changing the values of the shunt resistors.

9.5 Jumper configuration

This section provides jumper settings for configuring the STEVAL-IHM032V1 board.

Two types of jumpers are used on the STEVAL-IHM032V1 board:

- 3-pin jumpers with two possible positions, the possible settings for which are presented in the following sections
- 2-pin jumpers with two possible settings: if fitted, the circuit is closed, and when not fitted, the circuit is open

The STEVAL-IHM032V1 board can also be configured using a set of 0 ohm resistors. These resistors are used as 2-pin jumpers with two possible settings: Mounted; the circuit is closed, and Not mounted; the circuit is open.

9.5.1 Current sensing network jumper settings

The current sensing network can be configured for bipolar current reading or for unipolar current reading.

In the first case (bipolar current reading), the current flows in the shunt resistor in both directions: to the ground and from the ground. This is the case of sinusoidal control and the current sensing network must make sure to add an offset value in order to measure the negative values.

In the second case (unipolar direction), the current flows only in one direction: to the ground. This is the case of trapezoidal control and the current sensing network is not required to add

an offset. Anyhow, it is possible to add a small offset to avoid the saturation of the op amp to the minimum value for low value of motor current.

Jumper J16 is used to select the value of the offset added by the current sensing network.

- J16 between pin 1 and pin 2 (default setting): the current sensing network adds an output offset of 1.86 V (see [Section 9.4](#)). This configuration should be used for sinusoidal control.
- J16 between pin 2 and pin 3: the current sensing network adds a small offset to avoid the saturation of the op amp for low value of motor current (see [Section 9.4](#)). This configuration can be used for trapezoidal control.
- J16 open: the current sensing network doesn't add any offset.
- Jumper J17 is used to change the amplification gain of the current sensing network.
- J17 fitted (default setting): the current sensing network amplification gain value is set to 2.91. This configuration should be used for sinusoidal control having a $V_{dd_micro} = 3.3$ V.
- J17 not fitted: the current sensing network amplification gain is increased by adding $R_{60} = 5.6$ k Ω resistor in series to the R_{34} and R_{59} (see [Section 9.4](#)). This configuration can be used for trapezoidal control having a $V_{dd_micro} = 5$ V.

9.5.2 Bus voltage divider jumper setting

The default value of the bus voltage divider is sized to scale up to 400 V of DC bus voltage to 3.3 V maximum voltage. Changing the jumper J20 it is possible to modify the bus voltage divider.

- J20 mounted (default setting): the bus voltage divider value is 125. This configuration can be used having a $V_{dd_micro} = 3.3$ V.
- J20 not mounted: the bus voltage divider value is 88. This configuration can be used having a $V_{dd_micro} = 5$ V.

Note: The value of the bus voltage divider is computed considering the 100 k Ω resistor present in the voltage sensing input of the control stage.

9.5.3 Position feedback jumper setting

Two position feedback networks are present on the STEVAL-IHM032V1 board: BEMF zero crossing detecting network and Hall sensors/quadrature encoder sensor conditioning network.

Jumpers J13, J14, and J15 are used to select which of the two networks is connected with the motor control connector.

- J13, J14, and J15 between pin 1 and pin 2 (default setting): the BEMF zero crossing detecting network is fed into the motor control connector. The BEMF zero crossing is possible only in trapezoidal control.
- J13, J14, and J15 between pin 2 and pin 3: the Hall sensors/quadrature encoder sensor conditioning network is fed into the motor control connector.

9.5.4 BEMF zero crossing detection network enabling

The BEMF zero crossing detection network can be enabled or disabled using jumpers J9, J10, and J11.

- J9, J10, and J11 fitted (default setting): the BEMF zero crossing detection network is enabled. BEMF zero crossing is possible only in trapezoidal control.
- J9, J10, and J11 not fitted: the BEMF zero crossing detection network is disabled. If not required, it is possible in this way to cut off unwanted power consumption.

9.5.5 Motor control connector extra features enabling

It is possible to enable the motor control connector extra features using jumpers J5, J6, J7, J18, J19, and J22.

- J5 and J6 mounted (default setting): enables the cycle-by-cycle current regulation for trapezoidal control.
- J5 and J6 not mounted: disables the cycle-by-cycle current regulation for trapezoidal control.
- J7 mounted (default setting): enables the dynamic BEMF zero crossing sampling (during Ton or during Toff) for trapezoidal control.
- J7 not mounted: disables the dynamic BEMF zero crossing sampling (during Ton or during Toff) for trapezoidal control.
- J19 mounted (default setting): enables the overcurrent boost.
- J19 not mounted: disables the overcurrent boost.

Jumpers J18 and J22 are used to supply the control board via the MC connector.

- J18 not mounted (default setting): the V_{dd_micro} is not provided to the control board via pin 25 of MC connector J3
- J18 mounted: the V_{dd_micro} is provided to the control board via pin 25 of MC connector J3. Pin 25 of the MC connector can be used to provide the +5 V to the control board
- J22 mounted (default setting): the V_{dd_micro} is provided to the control board via pin 28 of MC connector J3. Pin 25 of the MC connector can be used to provide the +3.3 V to the control board
- J22 not mounted: the V_{dd_micro} is not provided to the control board via pin 28 of MC connector J3.

9.6 Motor control connector J3 pinout

Figure 12. Motor control connector J3 (top view)

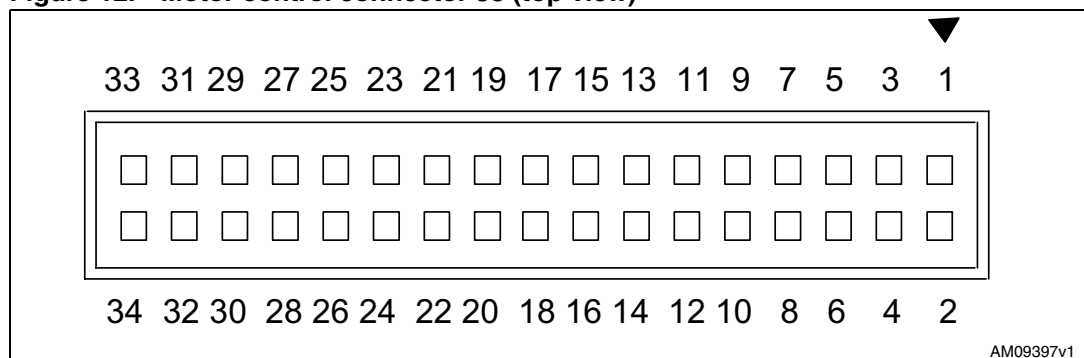

Table 4. Motor control connector J3 pin assignment

J3 pin	Function	J3 pin	Function
1	Emergency stop	2	GND
3	PWM-UH	4	GND
5	PWM-UL	6	GND
7	PWM-VH	8	GND
9	PWM-VL	10	GND
11	PWM-WH	12	GND
13	PWM-WL	14	Bus voltage
15	BEMF sampling method selection (see Section 9.5.5)	16	GND
17	Phase B current	18	GND
19	Not connected	20	GND
21	Not connected	22	GND
23	OCP boost (see Section 9.5.5)	24	GND
25	Not connected (see Section 9.5.5)	26	Heatsink temperature
27	6Step - current regulation feedback (see Section 9.5.5)	28	VDD μ
29	6Step - current regulation reference (see Section 9.5.5)	30	GND
31	H1/Enc A/BEMF A	32	GND
33	H2/Enc B/BEMF B	34	H3/Enc Z/BEMF C

10 Using the STEVAL-IHM032V1 with the STM32 FOC firmware library

The “STM32 FOC firmware library v3.0” provided together with the STM3210B-MCKIT performs the field-oriented control (FOC) of a permanent magnet synchronous motor (PMSM) in both sensor and sensorless configurations.

It is possible to configure the firmware to use the STEVAL-IHM032V1 as the power stage (power supply plus power block of [Figure 2](#)) of the motor control system.

This section describes the customization to be applied to the STM32 FOC firmware library V3.0 in order for the firmware to be compatible with the STEVAL-IHM032V1.

10.1 Environmental considerations

Warning: The STEVAL-IHM032V1 demonstration board must only be used in a power laboratory. The voltage used in the drive system presents a shock hazard.

The kit is not electrically isolated from the DC input. This topology is very common in motor drives. The microprocessor is grounded by the integrated ground of the DC bus. The microprocessor and associated circuitry are hot and MUST be isolated from user controls and communication interfaces.

Warning: Any measurement equipment must be isolated from the main power supply before powering up the motor drive. To use an oscilloscope with the kit, it is safer to isolate the DC supply AND the oscilloscope. This prevents a shock from occurring as a result of touching any single point in the circuit, but does NOT prevent shocks when touching two or more points in the circuit.

An isolated AC power supply can be constructed using an isolation transformer and a variable transformer.

Note: Isolating the application rather than the oscilloscope is highly recommended in any case.

10.2 Hardware requirements

The following items are required to run the STEVAL-IHM032V1 together with the STM32 FOC firmware library.

- The STEVAL-IHM032V1 board and MB525 board (STM32 demonstration board with MC connector) or any other demonstration board with an MC connector like: STEVAL-IHM022V1, STEVAL-IHM033V1, MB871, MB672
- A high-voltage insulated AC power supply up to 230 Vac
- A programmer/debugger dongle for the control board (not included in the package). Refer to the control board user manual to find a supported dongle. Use of an insulated dongle is always recommended.
- A 3-phase brushless motor with permanent magnet rotor (not included in the package)
- An insulated oscilloscope (as necessary)
- An insulated multimeter (as necessary)

10.3 Software requirements

To customize, compile and download the STM32 FOC firmware library v3.0, a toolchain must be installed. Please check the availability on the STMicroelectronics website or contact your nearest STMicroelectronics office to get documentation about the “STM32F103xx or STM32F100xx PMSM single/dual FOC SDK v3.0” and refer to the control board user manual for further details.

10.4 STM32 FOC firmware library v3.0 customization

To customize the STM32 FOC firmware library v.3.0 customization, the “ST Motor control workbench” can be used.

The required parameters for the power stage related to the STEVAL-IHM032V1 are reported in [Table 5](#).

Table 5. STEVAL-IHM032v1 motor control workbench parameters

Parameter	STEVAL-IHM032v1 default value	Unit
ICL shut out	Disabled	
Dissipative brake	Disabled	
Bus voltage sensing	Enabled	
Bus voltage divider	125	
Min. rated voltage	40	V
Max. rated voltage	380	V
Nominal voltage	325	V
Temperature sensing	Enabled	
$V_0^{(1)}$	1055	mV
T_0	25	°C
$\Delta V/\Delta T^{(1)}$	22	mV/°C

Table 5. STEVAL-IHM032v1 motor control workbench parameters (continued)

Parameter	STEVAL-IHM032v1 default value	Unit
Max. working temperature on sensor	70	°C
Overcurrent protection	Enabled	
Comparator threshold	0.55	V
Overcurrent network gain	0.45	V/A
Expected overcurrent threshold	1.2222	A
Overcurrent feedback signal polarity	Active low	
Overcurrent protection disabling network	Disabled (see Section 9.3)	
Current sensing	Enabled	
Current reading topology	1 shunt resistor	
Shunt resistor(s) value	0.45	Ω
Amplifying network gain	2.91	
T-rise	1000	ns
Power switches Min. dead-time	500	ns
Power switches Max. switching frequency	50	kHz
U,V,W driver High side driving signal	Active high	
U,V,W driver Low side driving signal Complemented from high side	Disabled	
U,V,W driver Low side driving signal Polarity	Active low	

1. These values are computed for $V_{dd_micro} = 3.3$ V, if the $V_{dd_micro} = 5$ V the values are $V_0 = 1600$ mV, $\Delta V/\Delta T = 34$ mV/°C.

11 Bill of material

Table 6. Bill of material

Reference	Part / value	Manufacturer	Manufacturer code
C7,C19,C46	4.7 nF	Any	
C9,C10,C17	470 nF	Any	
C3	22 nF	Any	
C13	22 nF	Any	
C14	2.2 nF	Any	
C15	33 pF	Any	
C18	100 μ F	Any	
C20	100 nF	Any	
C8,C11,C16	2.2 μ F		
C22	2.2 μ F	Any	
C12,C26,C27,C28	N.M.		
C29,C30,C31	470 pF	Any	
C32,C33,C34	10 pF	Any	
C37	10 nF	Any	
C47	22 μ F	Any	
C48,C49	100 μ F	Any	
D1,D3,D4,D6,D7,D8	1N4148	Any	
D2,D5,D9	LL4005	Taiwan Semiconductor	LL 4005G
D10,D11,D12,D13	STTH1R04U	STMicroelectronics	STTH1R04U
D14	BAT48Z	STMicroelectronics	BAT48ZFILM
D15,D16,D22	STTH1L06	STMicroelectronics	STTH1L06A
D17	GREEN LED SMD	Any	
D18,D19,D20	BAT54JFILM	STMicroelectronics	BAT54JFILM
D21	BZX84B15-V	NXP	BZX84-C15
F1	2 A	Wickmann	19372K-2A
J2	AC MAINS	Any	
J3	MOTOR_CONN	Any	
J4	Stripline m. 1x3	Any	
J5,J6,J7,J19,J20,J22	Small jumper	Any	
J18	Small jumper	Any	
J13,J14,J15,J16	Jumper	Any	

Table 6. Bill of material (continued)

Reference	Part / value	Manufacturer	Manufacturer code
J9,J10,J11,J17	Jumper	Any	
J12	CON3	Any	
J21	DC Bus	Any	
NTC1	5 Ω	EPCOS	B57236S509M
NTC2	NTC 10 k Ω	EPCOS	B57621C103J62
Q1,Q3,Q4,Q6,Q7,Q9	STGD3HF60HD	STMicroelectronics	STGD3HF60HDT4
Q2,Q5,Q8	BC817-25	Any	
Q10	N.M.		
R3	10 M Ω	Any	
R4,R16,R37	1 M Ω	Any	
R5,R12,R14,R21,R35,R41	10 Ω	Any	
R6,R13,R15,R23,R36,R43	100 Ω	Any	
R7,R8,R17,R18,R38,R39	180 k Ω	Any	
R9,R19,R40,R53,R54,R55,R68,R69	4.7 k Ω	Any	
R10,R20,R42	1 k Ω	Any	
R25,R30,R31,R33	1 k Ω	Any	
R11,R22,R44,R64,R66	10 k Ω	Any	
R26,R28	22 Ω	Any	
R27	2.2 k Ω	Any	
R29,R70	910 Ω	Any	
R32,R63,R71,R72	1.8 Ω	VISHAY	
R34,R59	2.7 k Ω	Any	
R45,R46	470 k Ω	Any	
R47	8.2 k Ω	Any	
R56,R57,R58,R73,R74	N.M.		
R60	5.6 k Ω	Any	
R61	3.9 k Ω	Any	
R62	1.5 k Ω	Any	
R65	10 Ω	Any	
R67	2 k Ω	Any	
TR1	SMAJ18A-TR	STMicroelectronics	SMAJ18A-TR
U1	LD1117S33TR	STMicroelectronics	LD1117S33TR
U2,U4	L6392D	STMicroelectronics	L6392D013TR
U3	L6391D	STMicroelectronics	L6391D013TR

Table 6. Bill of material (continued)

Reference	Part / value	Manufacturer	Manufacturer code
U5	VIPER12ASTR-E	STMicroelectronics	VIPER12ASTR-E
T1	Multiple inductor 1.41 mH 0.17 A	MAGNETICA	2092.0001

12 References

This user manual provides information on the hardware features and use of the STEVALIHM032V1 demonstration board. For additional information on supporting software and tools, refer to the following:

1. STGD3HF60HD datasheet
2. L6391 datasheet
3. L6392 datasheet
4. <http://www.st.com/mcu/> web site, which is dedicated to the complete STMicroelectronics microcontroller portfolio.

13 Revision history

Table 7. Document revision history

Date	Revision	Changes
19-May-2011	1	Initial release.
23-Jun-2011	2	Modified: Section 8.1

Please Read Carefully:

Information in this document is provided solely in connection with ST products. STMicroelectronics NV and its subsidiaries ("ST") reserve the right to make changes, corrections, modifications or improvements, to this document, and the products and services described herein at any time, without notice.

All ST products are sold pursuant to ST's terms and conditions of sale.

Purchasers are solely responsible for the choice, selection and use of the ST products and services described herein, and ST assumes no liability whatsoever relating to the choice, selection or use of the ST products and services described herein.

No license, express or implied, by estoppel or otherwise, to any intellectual property rights is granted under this document. If any part of this document refers to any third party products or services it shall not be deemed a license grant by ST for the use of such third party products or services, or any intellectual property contained therein or considered as a warranty covering the use in any manner whatsoever of such third party products or services or any intellectual property contained therein.

UNLESS OTHERWISE SET FORTH IN ST'S TERMS AND CONDITIONS OF SALE ST DISCLAIMS ANY EXPRESS OR IMPLIED WARRANTY WITH RESPECT TO THE USE AND/OR SALE OF ST PRODUCTS INCLUDING WITHOUT LIMITATION IMPLIED WARRANTIES OF MERCHANTABILITY, FITNESS FOR A PARTICULAR PURPOSE (AND THEIR EQUIVALENTS UNDER THE LAWS OF ANY JURISDICTION), OR INFRINGEMENT OF ANY PATENT, COPYRIGHT OR OTHER INTELLECTUAL PROPERTY RIGHT.

UNLESS EXPRESSLY APPROVED IN WRITING BY AN AUTHORIZED ST REPRESENTATIVE, ST PRODUCTS ARE NOT RECOMMENDED, AUTHORIZED OR WARRANTED FOR USE IN MILITARY, AIR CRAFT, SPACE, LIFE SAVING, OR LIFE SUSTAINING APPLICATIONS, NOR IN PRODUCTS OR SYSTEMS WHERE FAILURE OR MALFUNCTION MAY RESULT IN PERSONAL INJURY, DEATH, OR SEVERE PROPERTY OR ENVIRONMENTAL DAMAGE. ST PRODUCTS WHICH ARE NOT SPECIFIED AS "AUTOMOTIVE GRADE" MAY ONLY BE USED IN AUTOMOTIVE APPLICATIONS AT USER'S OWN RISK.

Resale of ST products with provisions different from the statements and/or technical features set forth in this document shall immediately void any warranty granted by ST for the ST product or service described herein and shall not create or extend in any manner whatsoever, any liability of ST.

ST and the ST logo are trademarks or registered trademarks of ST in various countries.

Information in this document supersedes and replaces all information previously supplied.

The ST logo is a registered trademark of STMicroelectronics. All other names are the property of their respective owners.

© 2011 STMicroelectronics - All rights reserved

STMicroelectronics group of companies

Australia - Belgium - Brazil - Canada - China - Czech Republic - Finland - France - Germany - Hong Kong - India - Israel - Italy - Japan - Malaysia - Malta - Morocco - Philippines - Singapore - Spain - Sweden - Switzerland - United Kingdom - United States of America

www.st.com