



STM32L4 – Interconnect Matrix

Interconnect Matrix

Revision 3.1



Hello and welcome to this presentation of the STM32 Interconnect Matrix. It covers the main features of this matrix, which is widely used to connect various internal peripherals between each other.

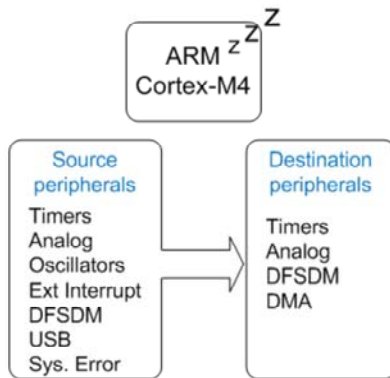

- Provides direct connections between peripherals.

Application benefits

- Time-predictable operations
- Decreased power consumption
- Reduced GPIO usage

The Interconnect Matrix integrated inside STM32 products provides direct connections between peripherals.

Applications benefit from these interconnections to ensure time-predictable operations, to decrease power consumption by avoiding complex management of peripheral communications through reading/writing registers using CPU instructions and, in some cases, reducing the need to loop the signal from a source to a destination through a dedicated GPIO.

Key features 3

- Direct, autonomous connections between peripherals
 - Removes latency in regards to software handling
 - Saves CPU resources
 - Removes the need for looping signals through a dedicated GPIO

- Can operate during Low-power mode (depending on peripheral)



The Interconnect Matrix offers two main features. First, it ensures direct and autonomous connections between peripherals, allowing to remove latency in regards to software handling, thus saving GPIO and CPU resources.

Second, the interconnection between certain peripherals can even operate during low-power modes.

Sources and destinations

Plenty of interconnect possibilities available

- Source peripherals

- Timers: TIMx, LPTIMx, RTC
- Analog IPs: ADCx, OPAMPx, COMPx, DACx, VrefInt, VBAT, Temp Sensor
- Clocks: HSE, LSE, MSI, LSI, HSI16, MCO
- EXTI, DFSDM, USB
- System error

- Destination peripherals

- Timers: TIMx, LP TIMx, IRTIM
- Analog IPs: ADCx, OPAMPx, COMPx, DACx
- DFSDM, DMA

Source	Destination													
	TIM1	TIM8	TIM2	TIM3	TIM4	TIM5	TIM6	TIM7	TIM15	TIM16	TIM17	LPTIM1	LPTIM2	ADC1
TIM1	-	1	1	1	1	-	-	-	1	-	-	-	-	2
TIM8	-	-	1	-	1	1	-	-	-	-	-	-	-	2
TIM2	1	1	-	1	1	1	-	-	-	-	-	-	-	2
TIM3	1	-	-	1	-	-	-	-	-	-	-	-	-	2
TIM4	1	1	-	-	-	-	-	-	-	-	-	-	-	2
TIM5	-	1	-	-	-	-	-	-	-	-	-	-	-	-
TIM6	-	-	-	-	-	-	-	-	-	-	-	-	-	2
TIM7	-	-	-	-	-	-	-	-	-	-	-	-	-	-
TIM15	1	-	-	1	-	-	-	-	-	-	-	-	-	2
TIM16	-	-	-	-	-	-	-	-	1	-	-	-	-	-
TIM17	-	-	-	-	-	-	-	-	1	-	-	-	-	-

Details in reference manual.



The main peripherals having direct, autonomous interconnections are timers, analog IPs, clocks, extended interrupt/event controller, digital filters for sigma-delta modulators, USB and System Error for the connection sources. And timers, analog IPs, digital filters for sigma-delta modulators and direct memory access controllers for the connection destinations.

• Most interconnections are able to work in low-power modes

- All interconnections (except USB to TIM2) work in the following power modes:
 - Run, Sleep, Low-power run and Low-power sleep modes
- Connections from RTC, COMP1, COMP2 to low-power timer (LPTIM1/LPTIM2)
 - Also work in Stop0, Stop 1 and Stop 2 (LPTIM1 only) modes
 - Connection from USB to timer (TIM2)
Only works in Run and Sleep modes



Peripherals can be interconnected using the Interconnect Matrix even when the circuit is in a low-power mode.

The low-power modes that can be used are: Run, Sleep and Low-power sleep modes; except for the USB to Timer 2 connection, which can only be used in Run and Sleep modes.

The connections from the real-time clock or comparators to low-power timers can also be used in Stop0, Stop 1 and Stop 2 modes for Low-power Timer 1.

- Timer synchronization or chaining
- Triggering of ADC, DAC, DFSDM or COMP (by Timer or EXTI)
- Triggering of timers (by ADC, DFSDM, RTC, COMP or USB)
- Triggering of DMA data transfer from memory to DAC (by Timer)
- Calibration of HSI16/MSI/LSI clocks
- Dual-ADC mode
- Temperature and voltage monitoring
- Analog IP interconnects (OPAMP/DAC to ADC, DAC to OPAMP)
- Protection of timer-driven power switches (System Error to Timer)
- Infrared signal generation (Timer to IRTIM)



The Interconnect Matrix is mostly used for:

- Synchronizing or chaining timers, for example allowing a master timer to reset or trigger a second slave timer
- Triggering an ADC, DAC, digital filter for sigma-delta modulator or comparator through a timer event or an external interrupt
- Triggering a timer through an ADC or DFSDM watchdog signal when a predefined threshold value is crossed by the analog input
- Timers can also be triggered by a DFSDM short-circuit detection, or by a real-time clock interrupt at a given time or at a regular interval
- Timers can also be triggered based on a comparator output value, or when a USB Start Of Frame is detected
- Triggering a DMA data transfer from memory to the DAC by a timer to allow a frequency-controlled conversion
- Calibrating HSI16/MSI/LSI clocks, for example

measuring the external oscillator LSE frequency by a timer clocked by the calibrated internal oscillator

Dual-ADC mode, using ADC1 as the master to trigger a start of conversion for the ADC2 slave

Monitoring the temperature of a connected internal temperature sensor or the VBAT to ADC voltage

Analog IP interconnects, for example, connecting an op amp or DAC to an ADC, or a DAC to an op amp

Protecting timer-driven power switches through the direct connection of System Error signals to the timer break input

Infrared pulse modulation signal waveform generation using 2 timers

Application examples 7

- ADC to DFSDM direct connection to use DFSDM filtering capabilities (only on STM32L45x/46x/49x/4Ax devices).



On STM32L45x/46x/49x/4Ax devices, the internal ADC results can be directly connected to the DFSDM inputs in order to use the DFSDM filtering capabilities.

Timer synchronization example

8

- Timer 3 can act as a prescaler for Timer 2

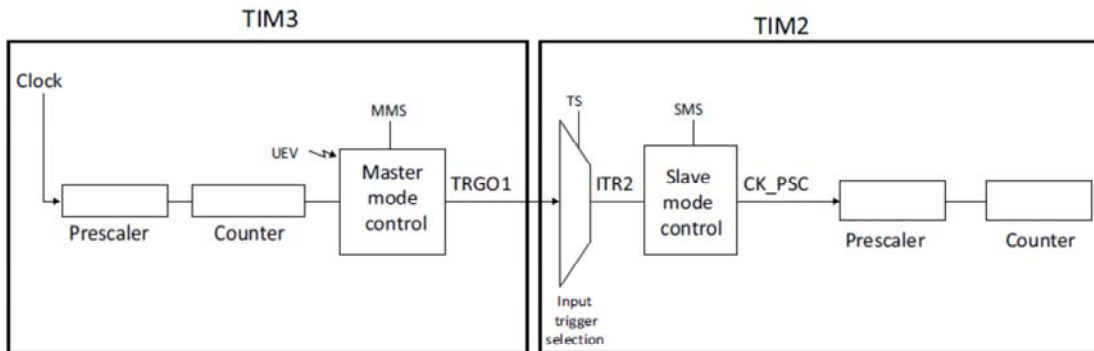

This slide shows a simple example of timer synchronization. The Timer 3 is used as the Master Timer and can reset, start, stop or clock the Timer 2 configured in Slave mode. In this example, Timer 3 is clocking the Timer 2 so that it acts as a prescaler for Timer 2.

- For more details, please refer to:
 - Reference manuals for STM32L4 microcontrollers



For more details about the Interconnect Matrix, refer to reference manual for STM32L4 microcontrollers.