



48V application for AI Server

Jerry LIN

Agenda

1

Driving Power Evolution in
Modern Data Center

2

ANATOMY OF 48-V Server
Power

3

48V input benefit

4

ST for 48V Solutions



Driving power evolution in modern data centers

Complete solution for Direct/Dual Stage power delivery in 800V to xPU ecosystem

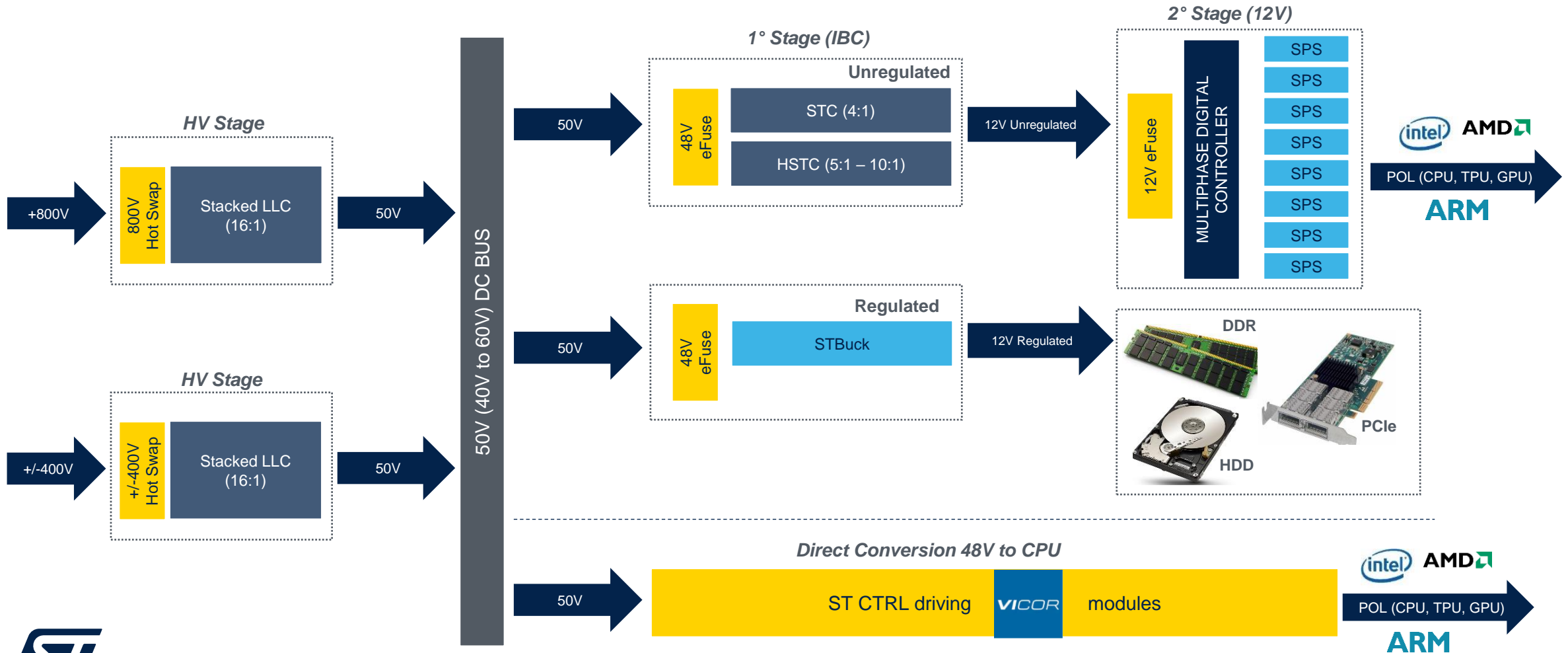

800V → 50V → 12V → POL ST comprehensive solution

800V → 50V

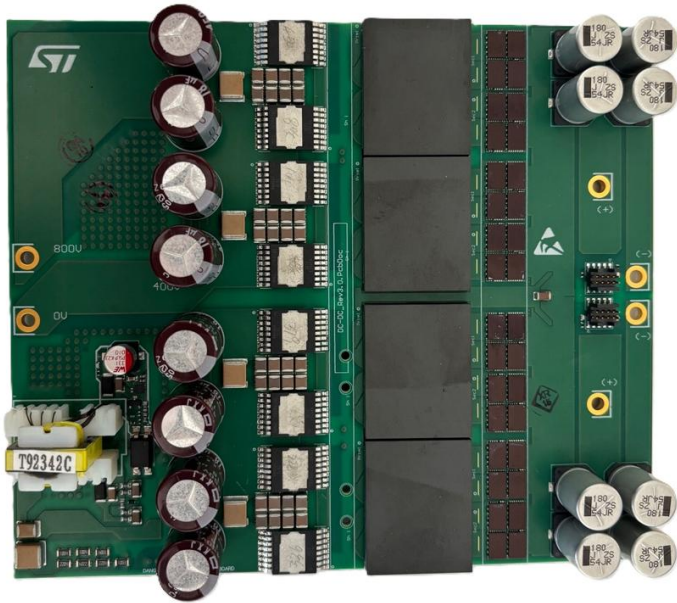

Drivers, GaN, MCU, DC-DC

50V → 12V



Digital Multiphase Controller, Driver, eFuse

12V → POL

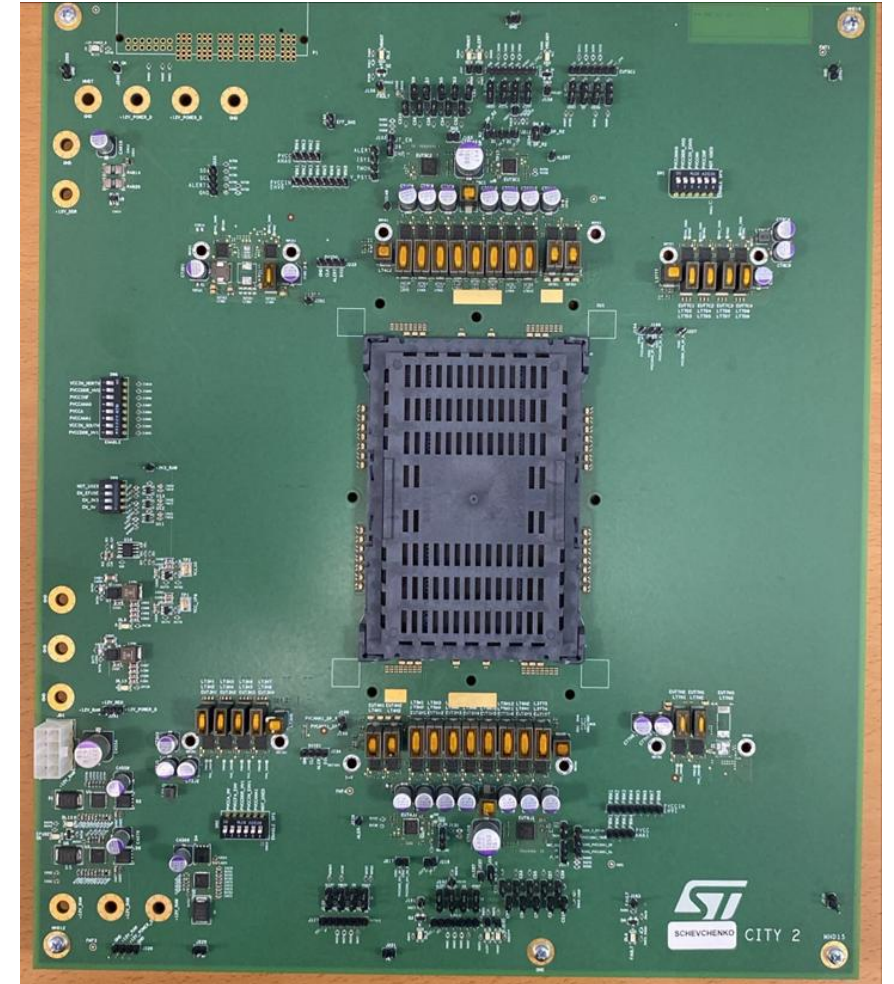

Digital Multiphase Controller, SPS, eFuse



Anatomy of a 48-V server power

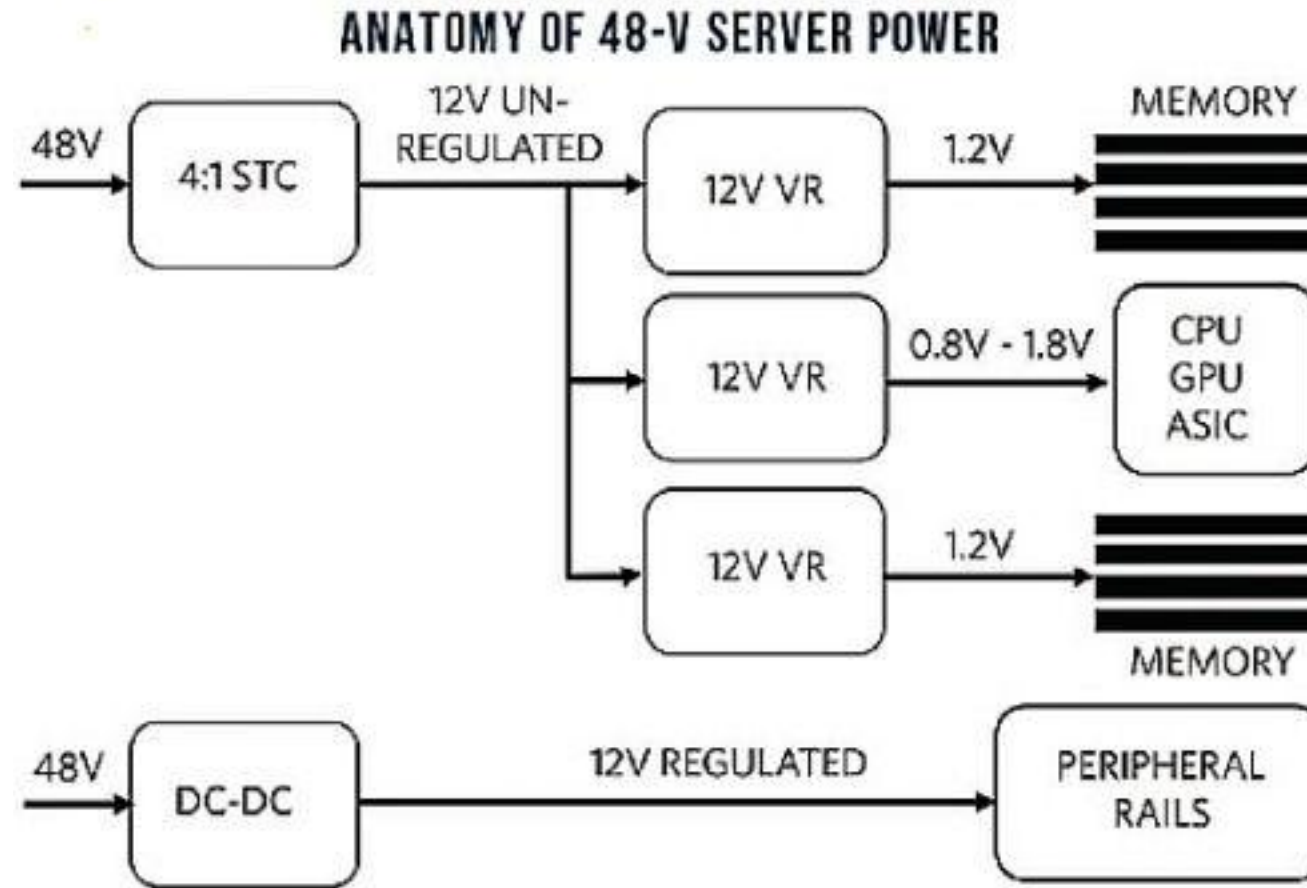

48V input benefits

1. Reduces I^2R power loss
2. Increases power density
3. Enhanced voltage regulation
4. Design flexibility
5. Compatible with renewable energy

ST for 48V Solutions



Dual Stage Conversion

Intermediate Bus: 48V → 12V

3 Topologies Available Based on Customer Needs For Server and Telecom 12V Bus Distributions

Unregulated

98.5 %
Efficiency



HSTC: Hybrid Switched Tank Converter

- Flexible Conversion Ratio
- Minimized BOM Count for Any Ratio
- ST Patent

HSTC Digital Controller
PM6780
VFQFPN 5x5mm

Full Bridge Driver
STPRDC02A
VFQFPN 4x4mm



Regulated

>98%
Efficiency



STB: STacked Buck Converter

- Si Based 1.6kW in ¼ brick solution
- High Power Capability up to 1.6kW x 4
- ST Patent
- Assurance of supply: 2nd source enabled for all components

STB Digital Controller
PM6780
QFN5x5

Full Bridge Driver
STPRDC02/A/B
VFQFPN 4x4mm

Intel VR13.HC
Intel VR14
Reference Design

Regulated

98.3 %
Efficiency



STB-GaN: STacked Buck GaN compliant

- GaN compliant 1kW in 1/8 brick
- Increased power density and/or efficiency
- Scalable Solution
- Assurance of supply

STB Digital Controller
PM6780
QFN5x5

Full Bridge Driver
STPRDC02GN
VFQFPN 4x4mm

STB

STB-UCL 1kW

Main Features

- Regulated output, non-Isolated
- Server and Telecom 12V Bus distribution
- Input Voltage: **38V-60V**
- Output Voltage: **12V** regulated (Adjustable by PMBus)
- Thermal Design Power (TDP): **1000W**
- Coupled inductor for higher density and efficiency
- Digital Controller **PM6779/PM6780**, STPRDC02/A Drivers
- Total Area: 58x37 mm (Quarter brick)

**98.3%
Efficiency**

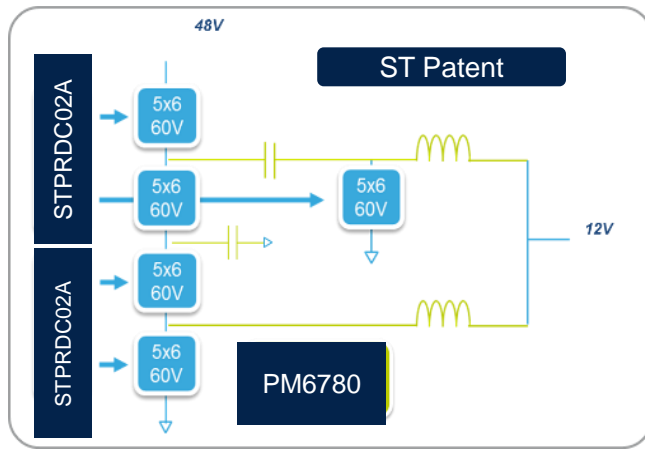

STB-UCL-1kW	
ST PN Used	Controller: PM6779/80 Driver: STPRDC02A
TDP (W) (*)	1000
Peak Power (W)	1100
Input Voltage (V)	38-60
Output Voltage (V)	12V
Regulated or Non-Regulated	Regulated
Efficiency at 54V (20%-60%-100%) (**)	98.0%-98.1%-97.3
Peak Efficiency (%) At Vin=54V	98.3
PCB Size (X, Y, Z) mm	58x37x15
Normalized BOM Cost	0.6

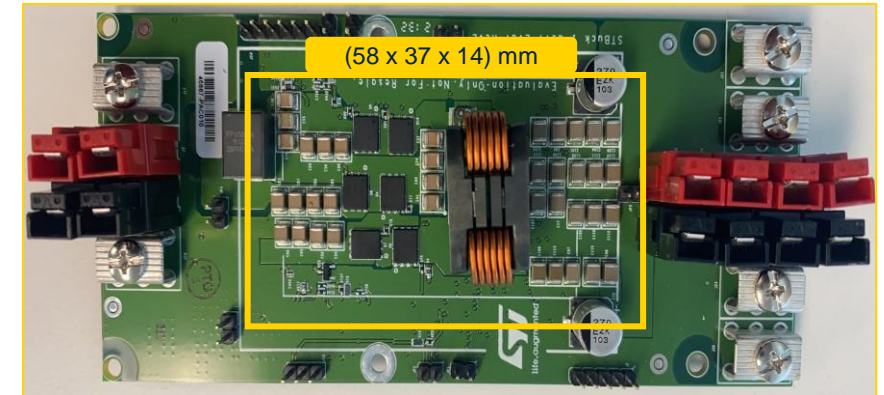

Driver losses and all bias Included. Vin=54V, 58V, 44V and 48V

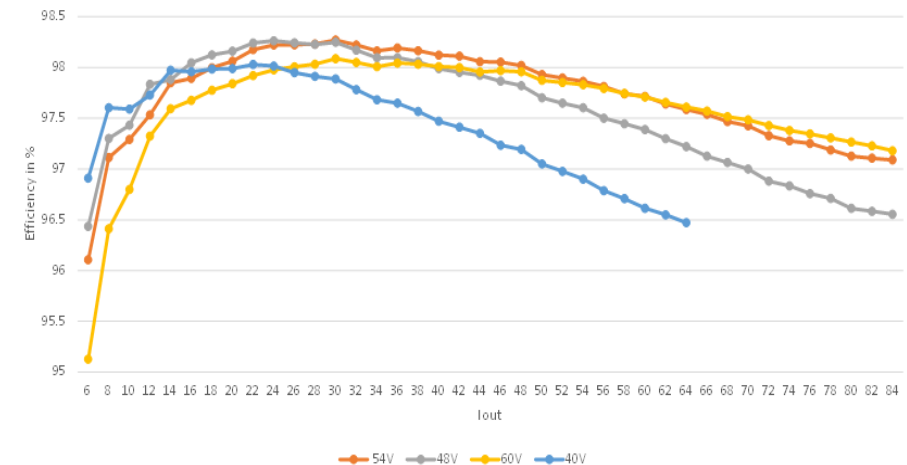

STB-UCL status

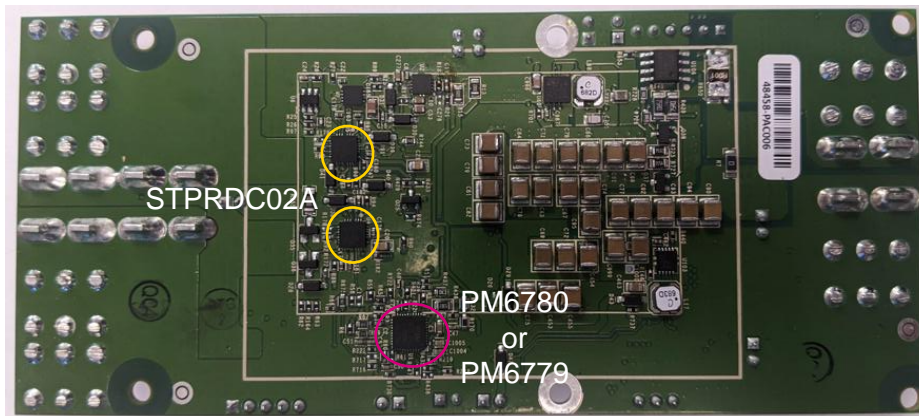
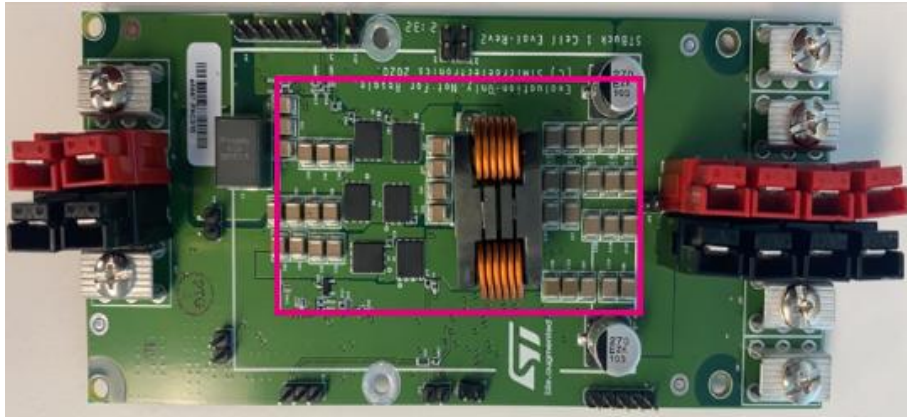

2 Inductors qualified:

- Vendor I: Max. 14.3mm height
- Vendor T: Max. 14mm height

2 MOSFET vendors Qualified

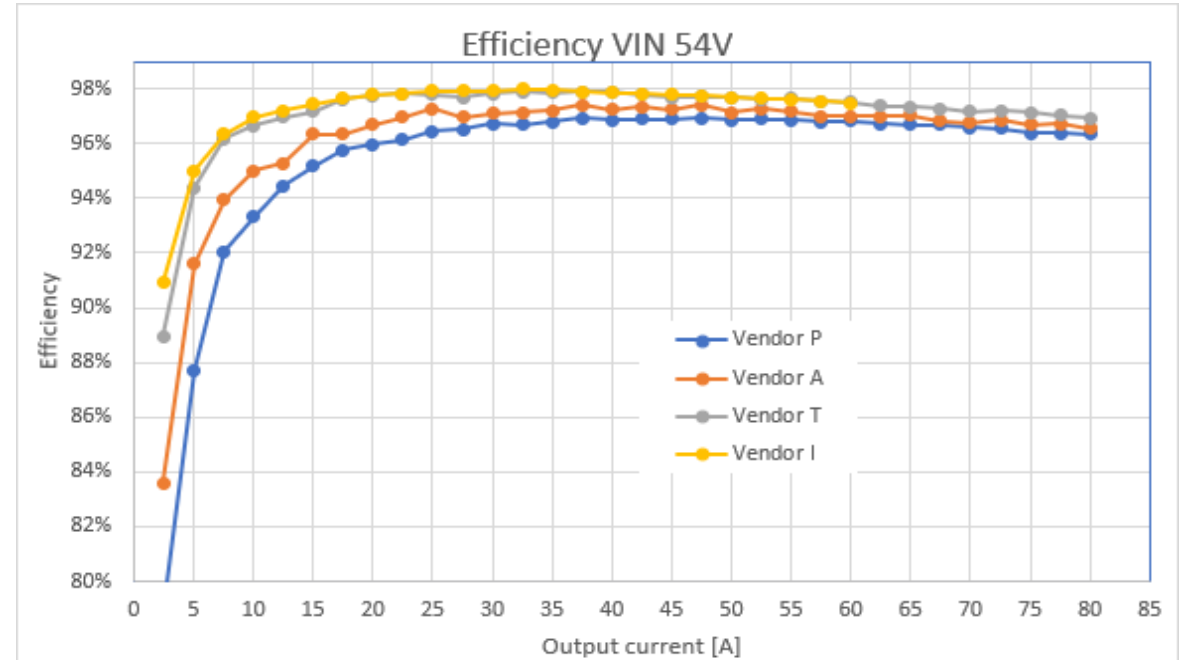

STB-UCL on-board solution is stable and validated:

- Solution qualified and in production at several customer
- Solution in qualification at >10 customers
- Extensive bench validation (EBV) completed successfully
- Chamber tests 3 batches (8 boards each) completed successfully

STB-UCL 1.6kW in ¼ brick

Main Features

- Regulated output, non-Isolated
- Server and Telecom 12V Bus distribution
- Input Voltage: **38V-60V**
- Output Voltage: **12V** regulated (Adjustable by PMBus)
- Thermal Design Power (TDP): **1.6kW**, up to **2kW**
- Coupled inductor for higher density and efficiency
- Digital Controller **PM6779/PM6780**, STPRDC02A/B Drivers
- Total Area: 58x37 mm (Quarter brick)

**98.1%
Efficiency**

STB-UCL-1.6kW

ST PN Used	Controller: PM6779/80 Driver: STPRDC02A/B
TDP (W) (*)	1600 or 2000
Peak Power (W)	Up to 2200W
Input Voltage (V)	38-60
Output Voltage (V)	12V
Regulated or Non-Regulated	Regulated

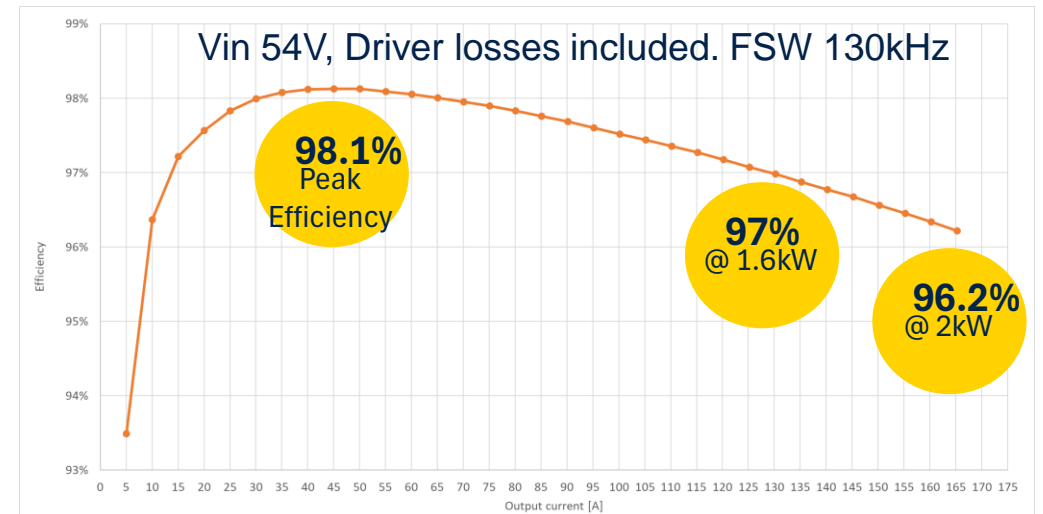
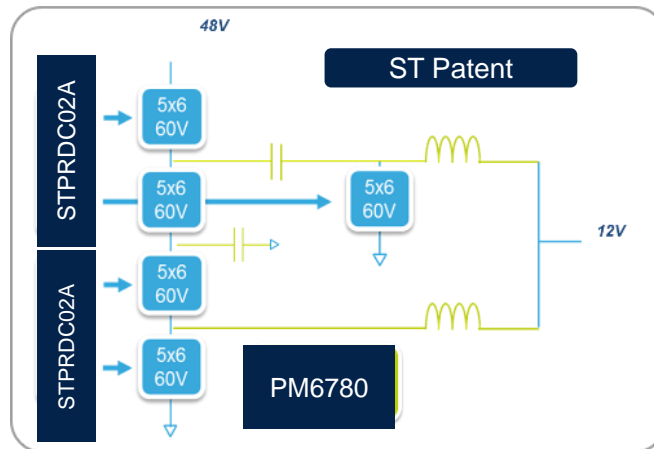
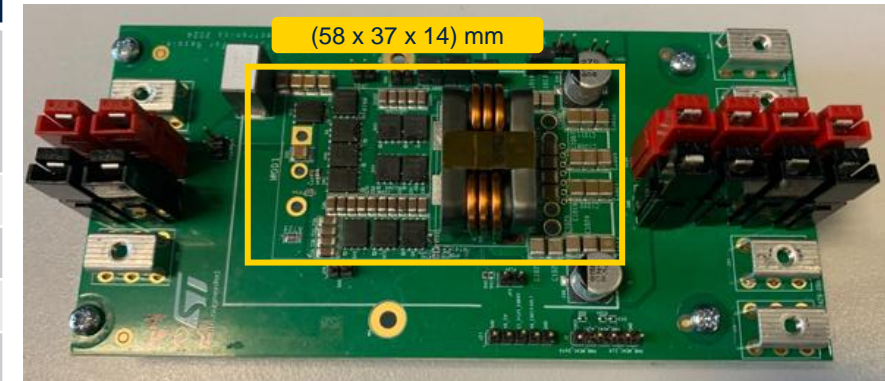

STB-GaN 1kW in 1/8 brick (58.4mm x 22.9mm)



Controller: ST PM6780

GaN optimized Driver: ST STPRDC02GN

High Frequency GaN optimized magnetic, qualifying 2 vendors P2P

GaN FETs: **6x EPC2361 for 1kW, 12x EPC2361 for 2kW**

Aux included in 1/8 brick

STB-GaN 2kW in 1/8 brick

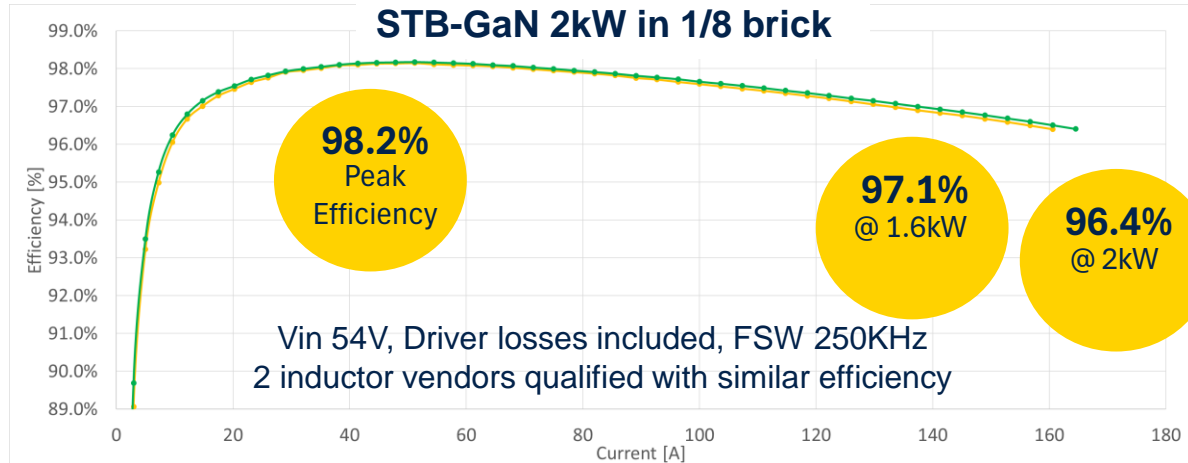

STB-GaN 1kW in 1/8 brick

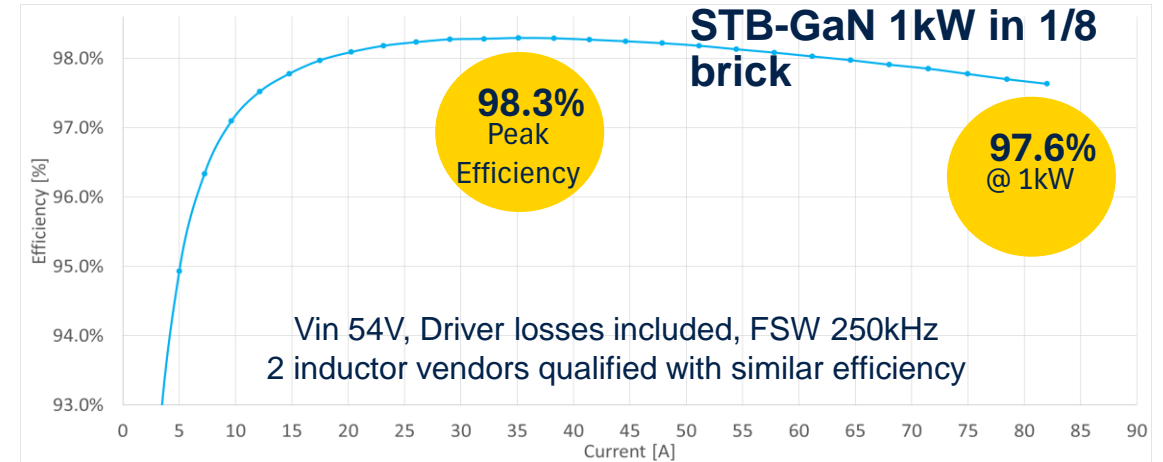

HSTC 750

Main Features

- Flexible conversion ratio
- Non-Regulated Output (5:1), non-Isolated
- Very High Efficiency and Power Density
- Minimized BOM for any conversion ratio
- Input Voltage: **38V-60V**
- Thermal Design Power (TDP): **750W (900W peak)**
- Higher power capability with interleaved power cells
- Digital Controller PM6779/80, STPRDC02A Drivers
- Total Area: 60x25 mm

**98.5%
Efficiency**

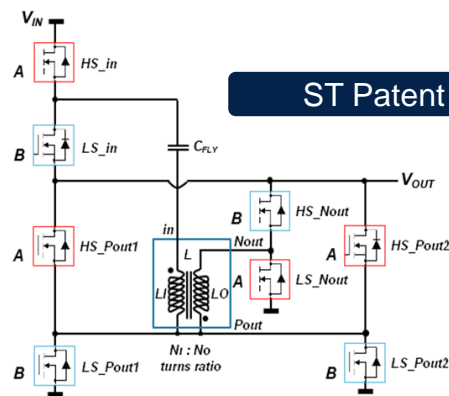

HSTC 750	
ST PN Used	Controller: PM6779/80 Driver: STPRDC02A
TDP (W) (*)	750
Peak Power (W)	900
Input Voltage (V)	38-60
Output Voltage (V)	5:1
Regulated or Non-Regulated	Non-Regulated
Efficiency at 54V (20%-60%-100%) (**)	98.4%-98%- 96.6%
Peak Efficiency (%) At Vin=54V	98.5
PCB Size (X, Y, Z) mm	60x25x12.5
Normalized BOM cost	0.6

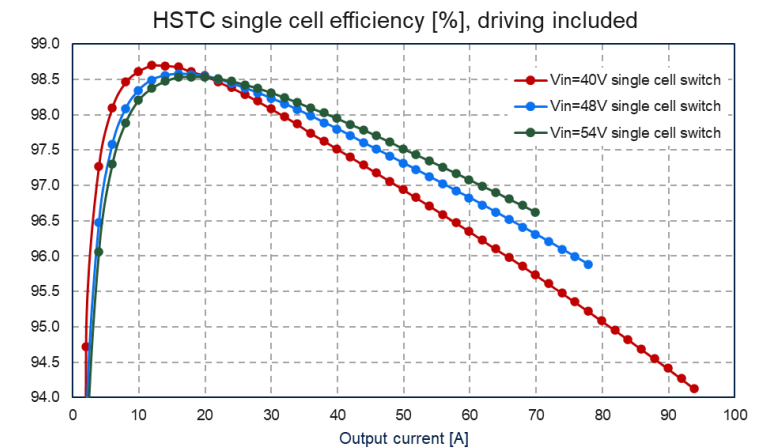
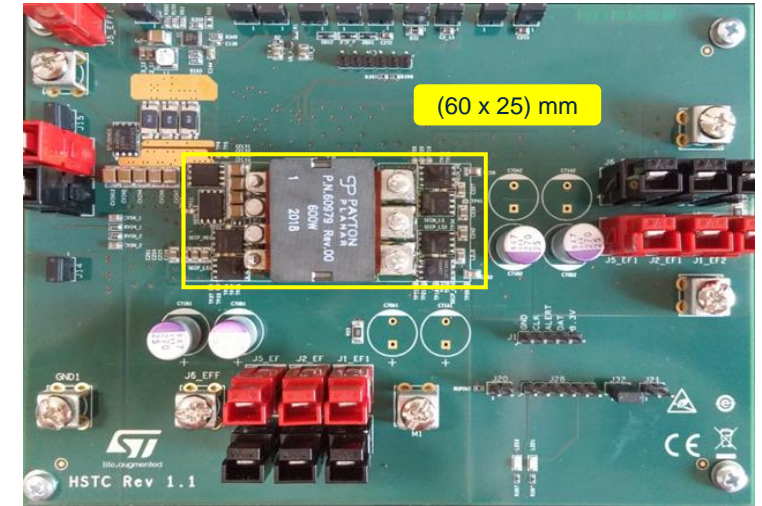

HD-HSTC – Hi-density hybrid switched tank converter

High efficiency, high-density intermediate bus solution with 48V eFuse

HD-HSTC Topology

- Flexible conversion ratio → 4:1 (driven by magnetic)
- Non-Regulated Output
- On board layout targeting stacked PCB similar to →
- Minimized BOM for any conversion ratio
- **48V eFuse on board.** NO Need for external hot-swap
 - NOT mandatory for the HD-HSTC
- Input Voltage: 38V-60V
- PM6780 Digital Controller
- STPRDC02A Full-Bridge Driver

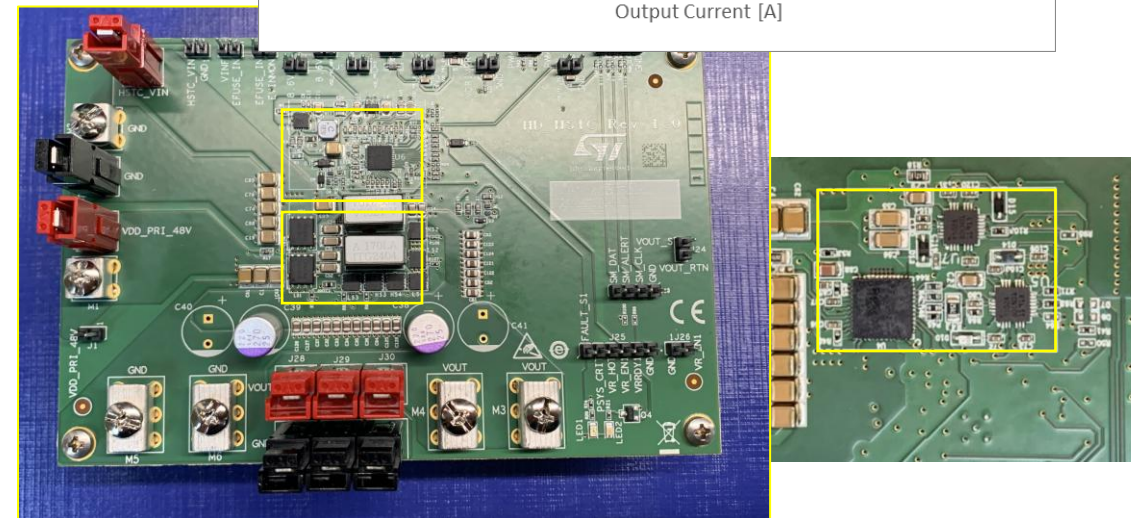
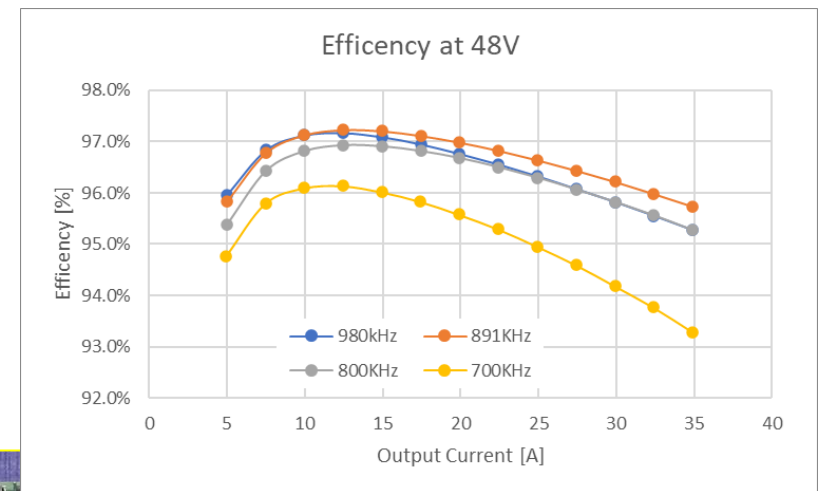
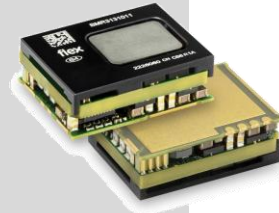

STC (Switched Tank Converter) Topology

48V→12V IBC Un-Regulated Conversion

Switched tank converter topology (STC)

Intel VR13.HC
ORION CITY
Reference Design



- Switched Tank Converter
- Low profile solution (<5mm)
- ZCS operation for all mosfet
- Only commercial MP parts required
- Suitable for conversion ratio up to 4:1

STC Controller
STNRG328A

FullBridge Driver
STPRDC02

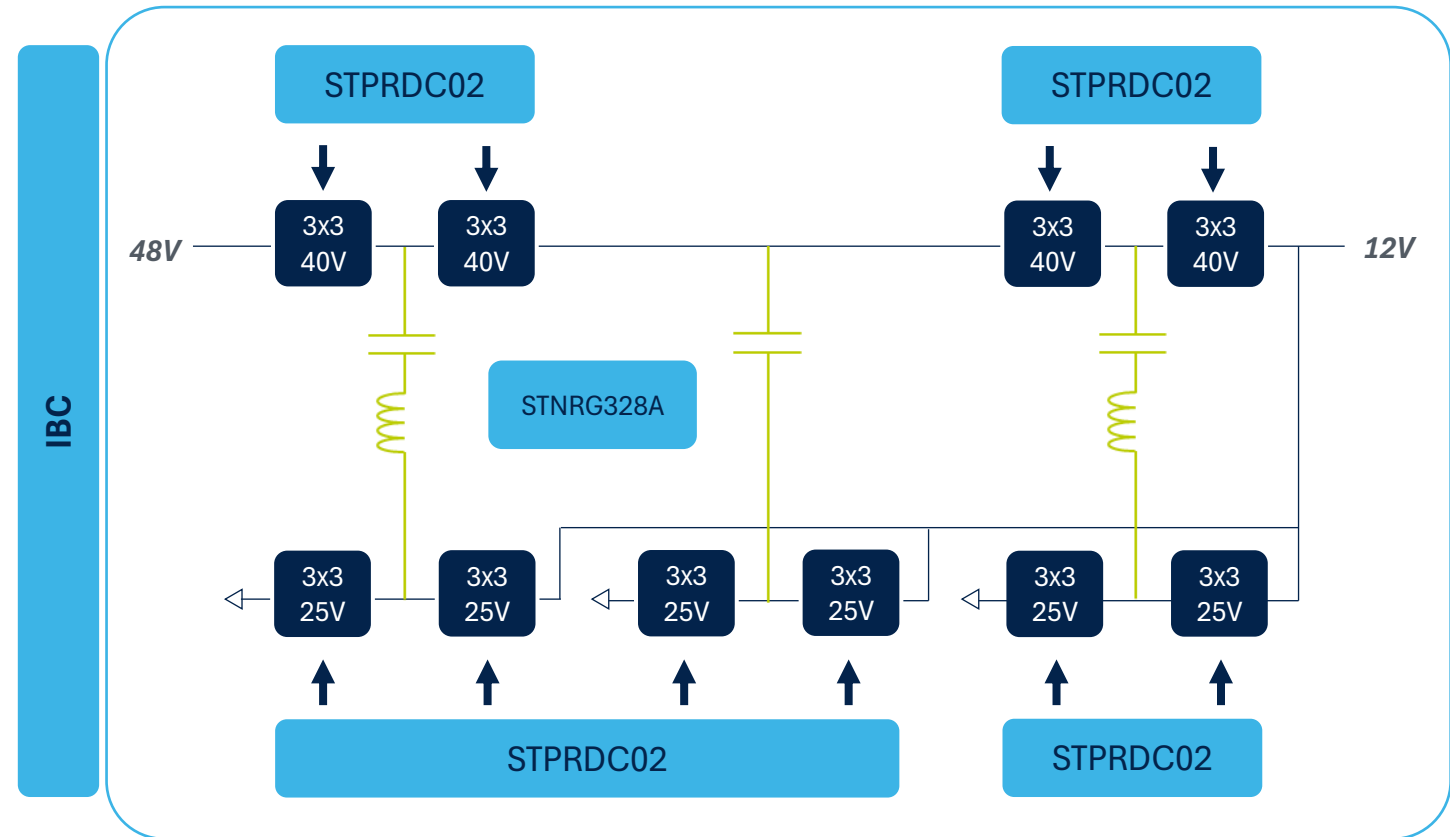

ST STC (4:1) 600W-1KW TDP with X7R

98.6%
Efficiency

600W (4:1) BOM (all X7R)

- Cres1: 10xGRM31CR71H475KA12L
- Cres2: 13xTMK212AB7475KG
- Lres: 2xTPI078060I056N
- STNRG328A + 4xSTPRDC02A
- 1/8 brick board size:
 - 500W: 20x54mm
- 1/4 brick board size:
 - 1KW: 40x54 mm



STPRDC02A New Driver Enables Usage of X7R Capacitors

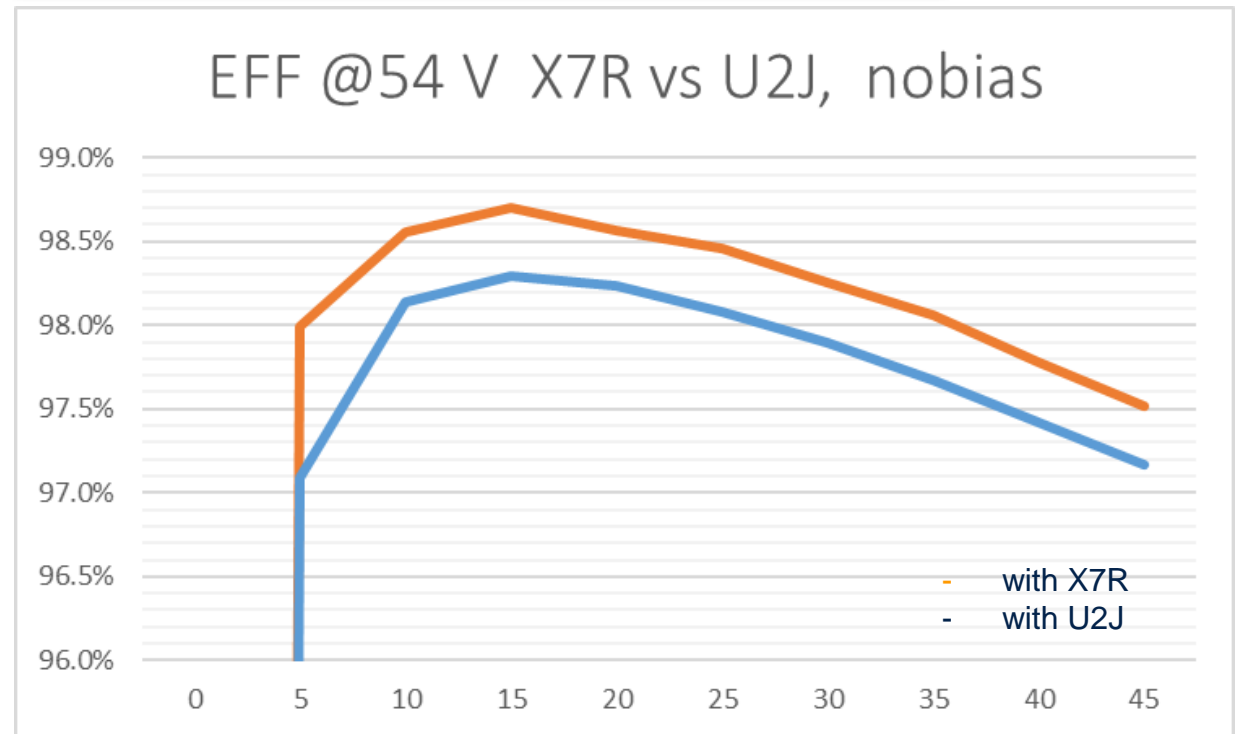

98%

ST STC-U2J, 1/8th Brick 1kW –TDP

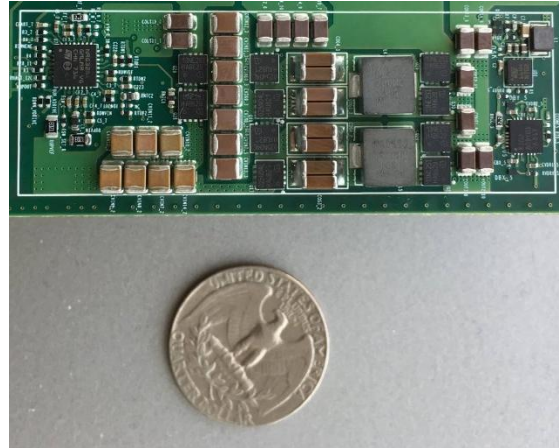

98%
Efficiency

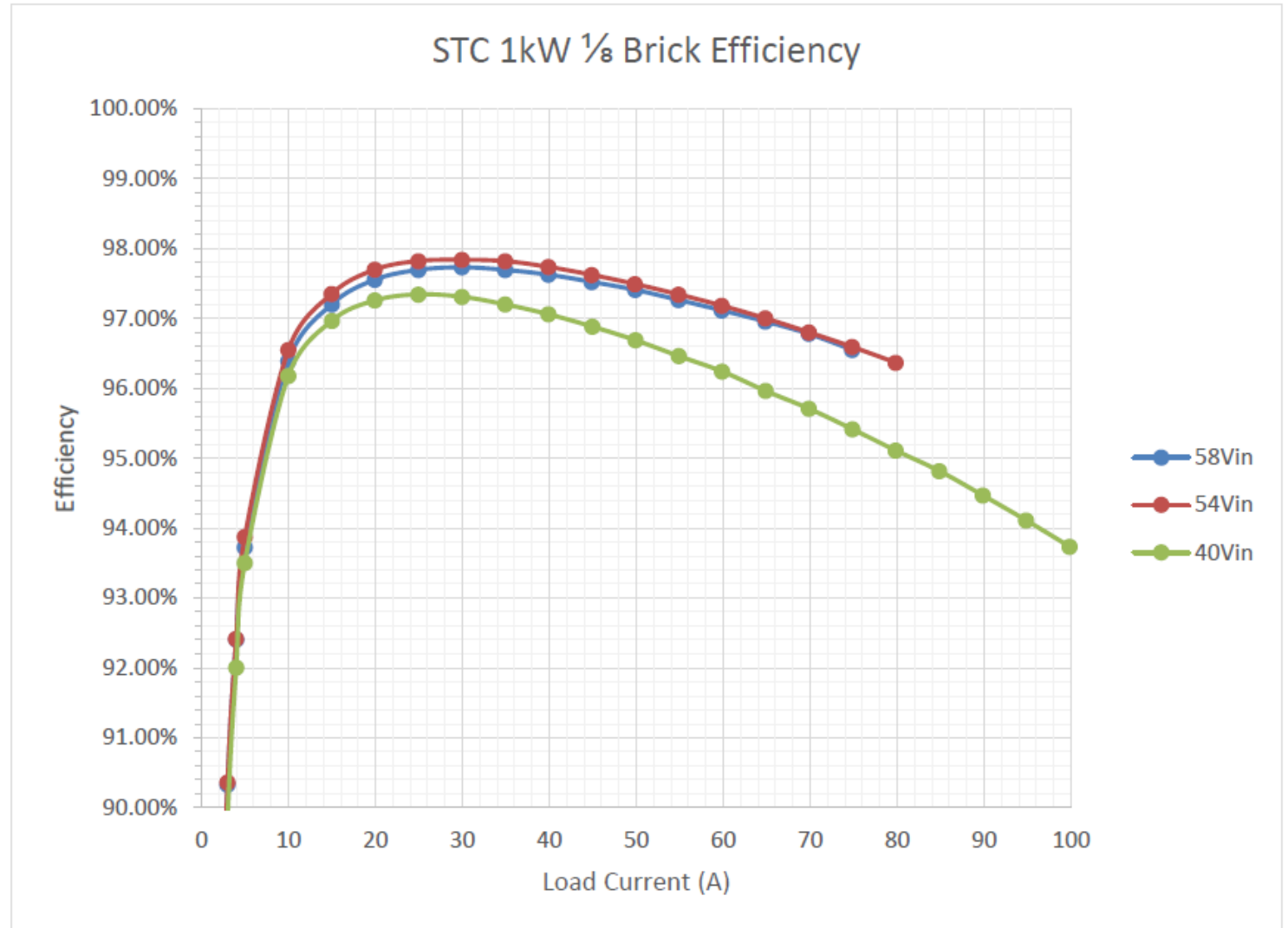
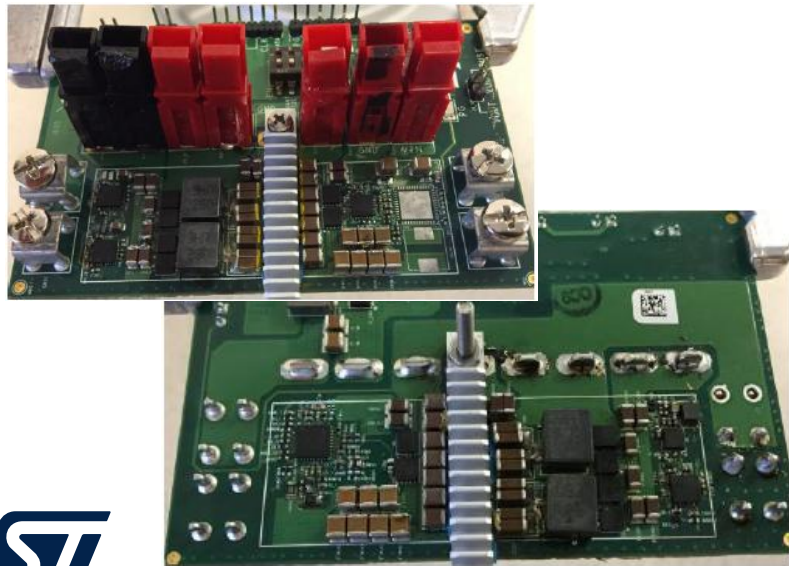

ST STC 600W-1KW TDP with X7R

- New driver STPRDC02A (pin to pin with previous one) supports ZCD feature
- Same controller (STPRDC02A) manages ZCD and adaptes switching freq and dead times
- PMBUS for telemetry and Tuning
- Available 4:1 , 3:1 and 2:1 solution , no parallel solution developmet yet
- Cost reduction using Input Hot swap
- All protection available and tested.
- Application Note availble

HSTC High Density 4:1 1st stage conversion

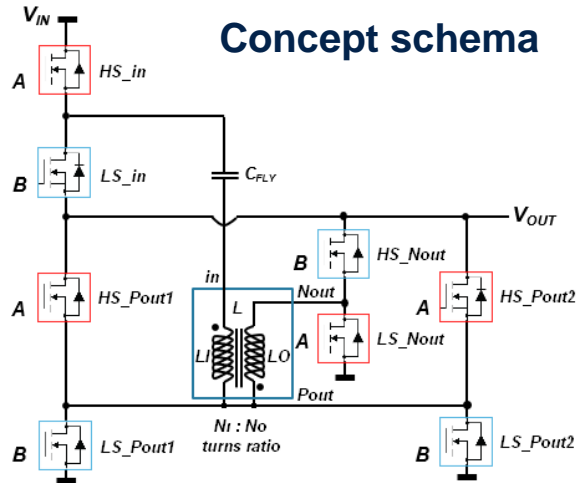

Concept schema

28x19.1mm
core
components
area

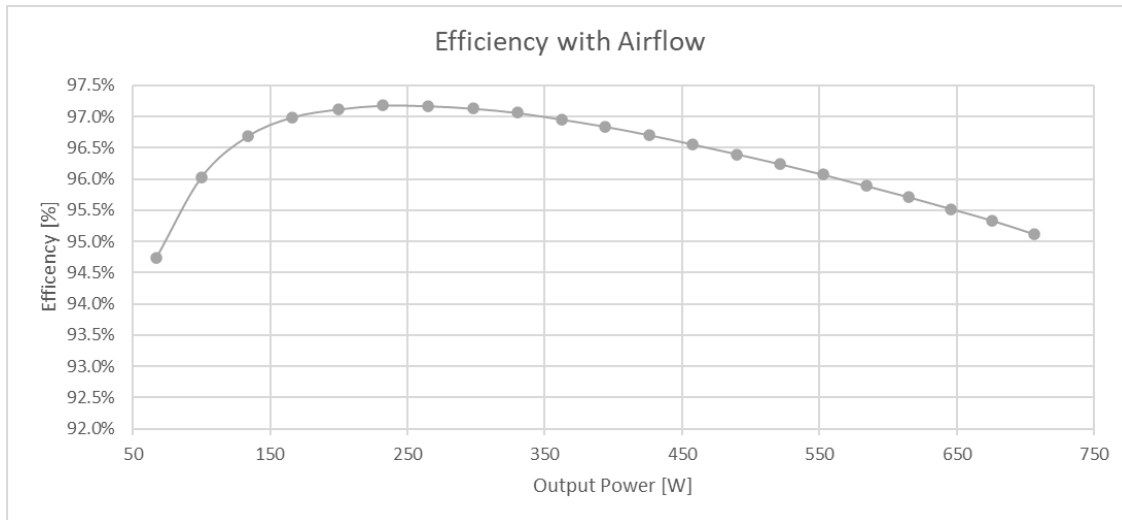

Peak efficiency **97.20%** @ 250W output power
95.10% efficiency @ **700W** output power



Power section (6L 2oz PCB):

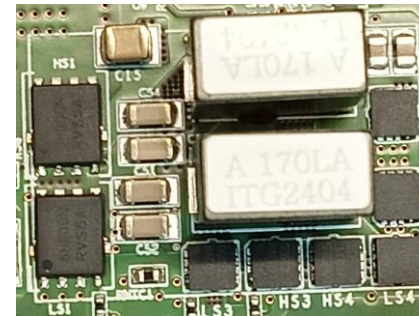

- Top Layer:
- 2x 80V power MOS
 - 6x 25V power MOS
 - 2x TLVR dual coil power inductors
 - 1x 100V Vin cap.
 - 4x 50V Cfly cap.
 - 2x 25V Vout cap.
 - 1x Rntc temperature sensing resistor

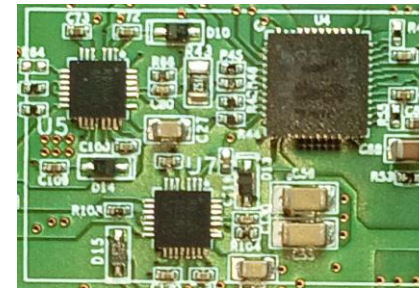

- Bottom Layer:
- 2x high voltage drivers
 - 1x integrated eFuse
 - 2x 50V Cfly cap.
 - SMD auxiliary components

Control & auxiliary supply section:

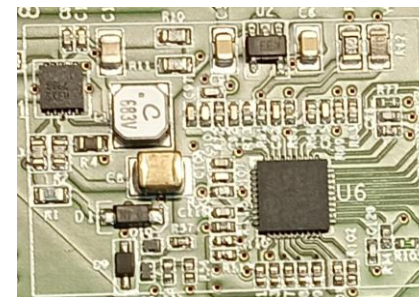

- Single Layer:
- 1x digital controller
 - 1x step-down switching regulator
 - 1x filtering inductor
 - 1x LDO regulator
 - SMD auxiliary components

Advantages of on-board solutions for IBA

- **Form Factor Flexibility:** high flexibility and layout customization to fit specific size, form factors and PCB requirements
- **Better Load Proximity:** PCB customization minimizes PCB trace lengths between the regulator output and the load
- **Optimized Efficiency at Load Terminal:** minimized PCB traces DCR resistance allow “best efficiency optimization”
- **Customized TDP Design:** system design optimization for the specific power need avoiding overkill situations (i.e., overdesign the power section)
- **Component procurement:** individual component procurement enables multiple source availability to mitigate shortage and allocation situations
- **TCO Maximization:** customized design provides competitive solution cost and efficiency performances

Data reference

- ¹ Brad Xiao and Nazzareno “Reno” Rossetti. “[Handling the 48-to-12-V Stepdown.](#)” Power Electronics Tips, February 2021.

Q&A

Thank you.



Our technology starts with You



Find out more at www.st.com

© STMicroelectronics - All rights reserved.

ST logo is a trademark or a registered trademark of STMicroelectronics International NV or its affiliates in the EU and/or other countries.

For additional information about ST trademarks, please refer to www.st.com/trademarks.

All other product or service names are the property of their respective owners.

