



Smart Switches for Automotive Electrification

Ryan HUANG

STMicroelectronics

APMS | APeC Taiwan

Agenda

- 1 Automotive E/E architecture
- 2 VIPower high-side drivers and STi2eFuse
- 3 Multi-channel switches
- 4 VIPower low-side drivers - OMNIFET



Automotive E/E architecture

Evolution in Automotive E/E Architecture Enablers and Next

Power Distribution evolution: from Centralized to Zone

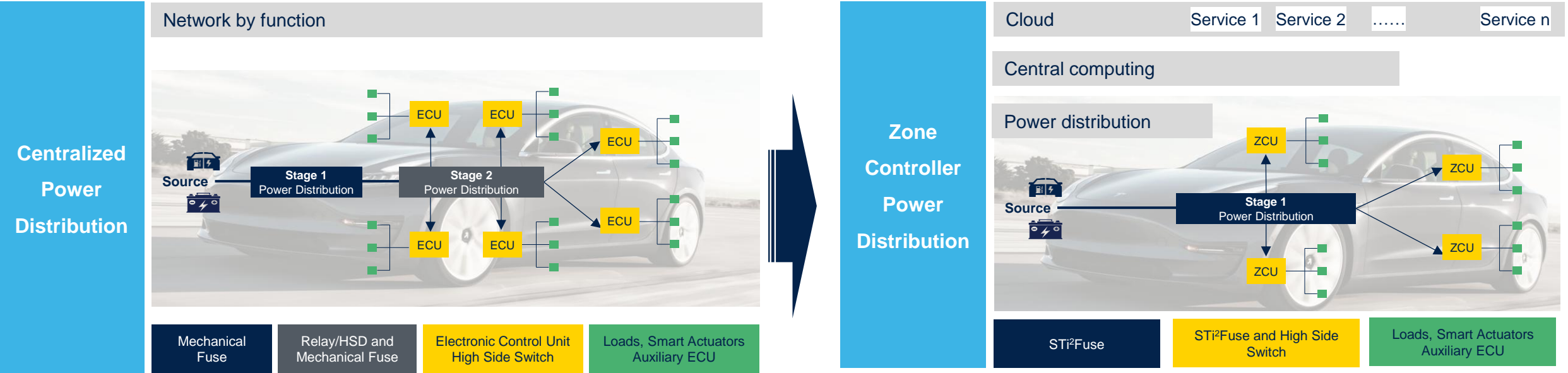

Transition supported by advanced fuse management: **STi²Fuse**

- Replacing both standard fuses and relays with **advanced diagnostics** and enhanced functional safety
- Significant overall weight reduction, up to 20%, due to **cable size optimization**
- Power Distribution Box equipped with Electronic fuses is **25%** lighter than mechanical one

E/E architectures enabling SDV

HW-enabled SW isolation/virtualization

Advanced safety and higher security

High-speed connectivity & Innovative OTA

Automotive Zonal EEA (Typical)

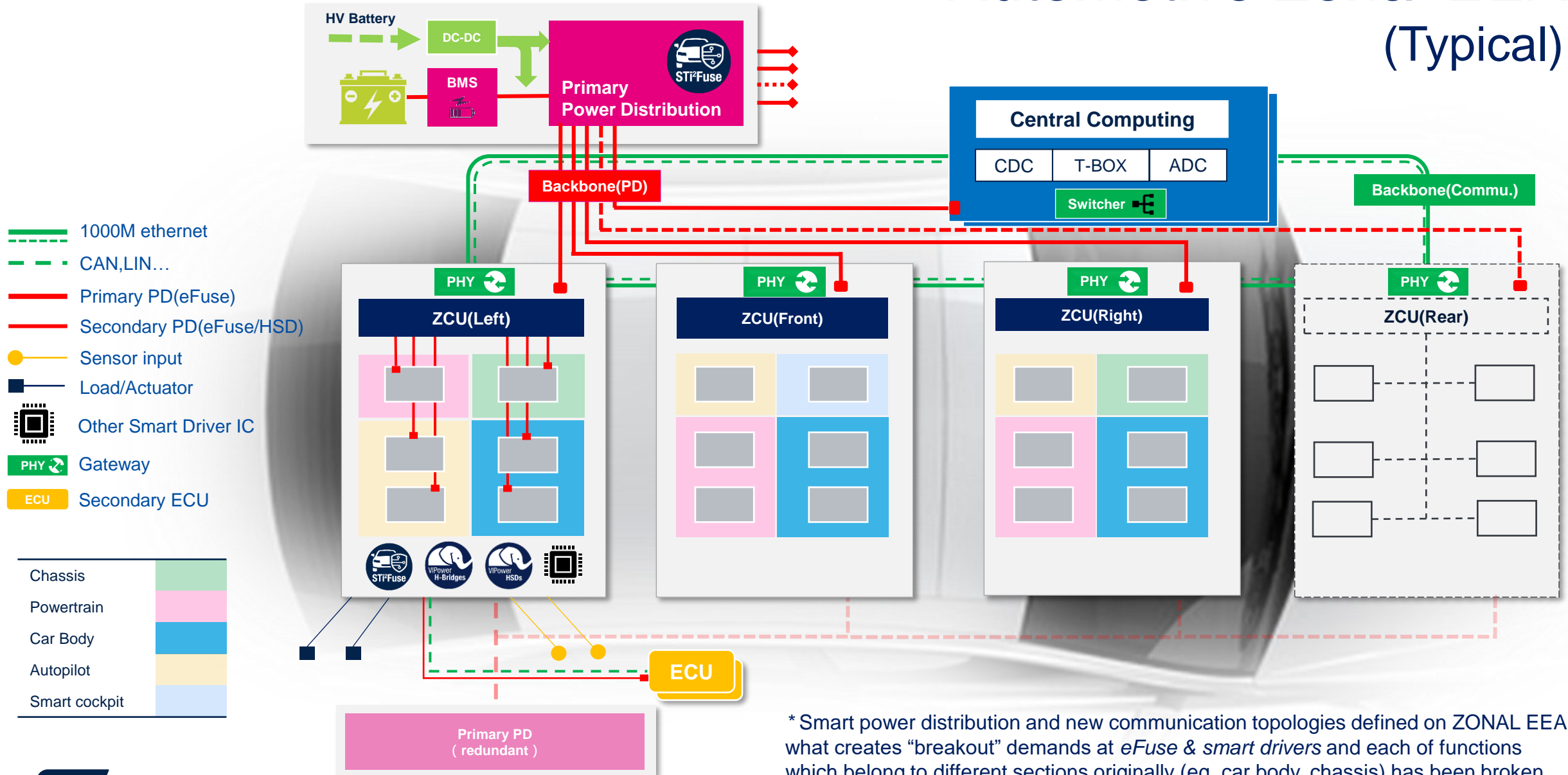

* Smart power distribution and new communication topologies defined on ZONAL EEA what creates “breakout” demands at eFuse & smart drivers and each of functions which belong to different sections originally (eg. car body, chassis) has been broken down into each vehicle interface units by principle of proximity.

Automotive Zonal EEA System requirement on Smart Switcher

(H S D / e F u s e)

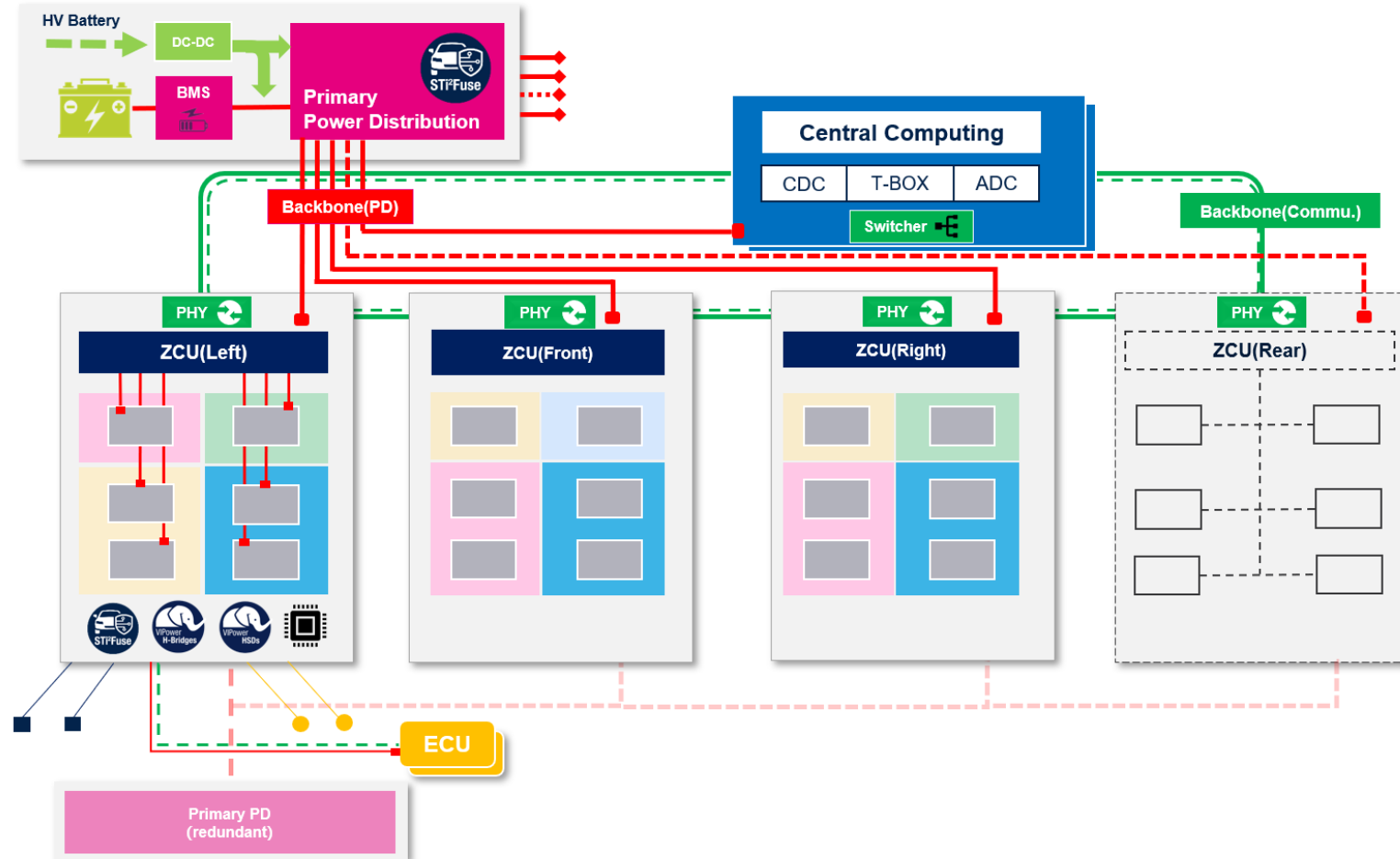
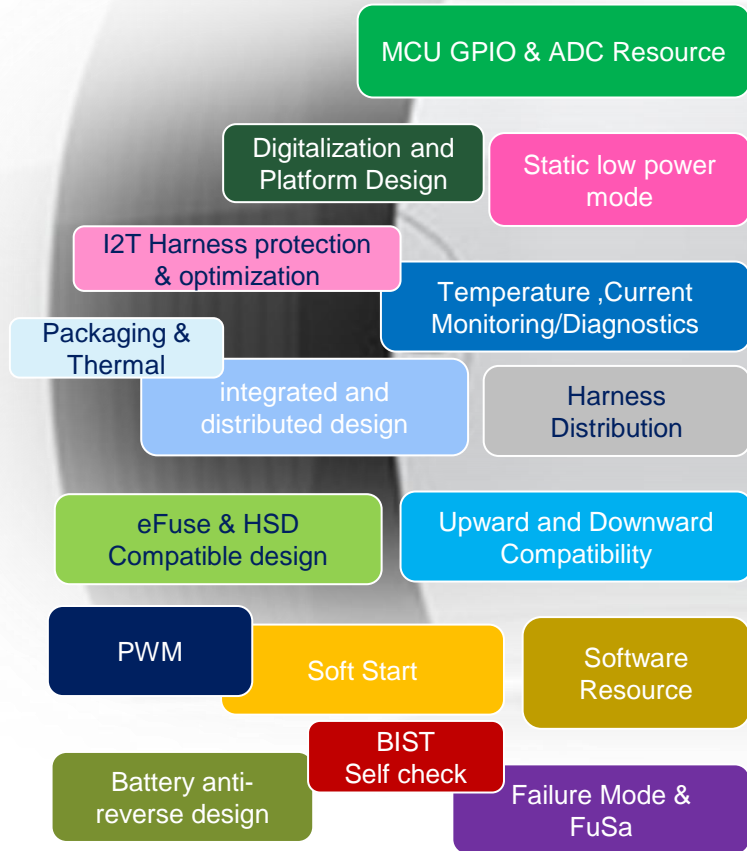

VIPower high-side drivers



VIPower Technology Evolution

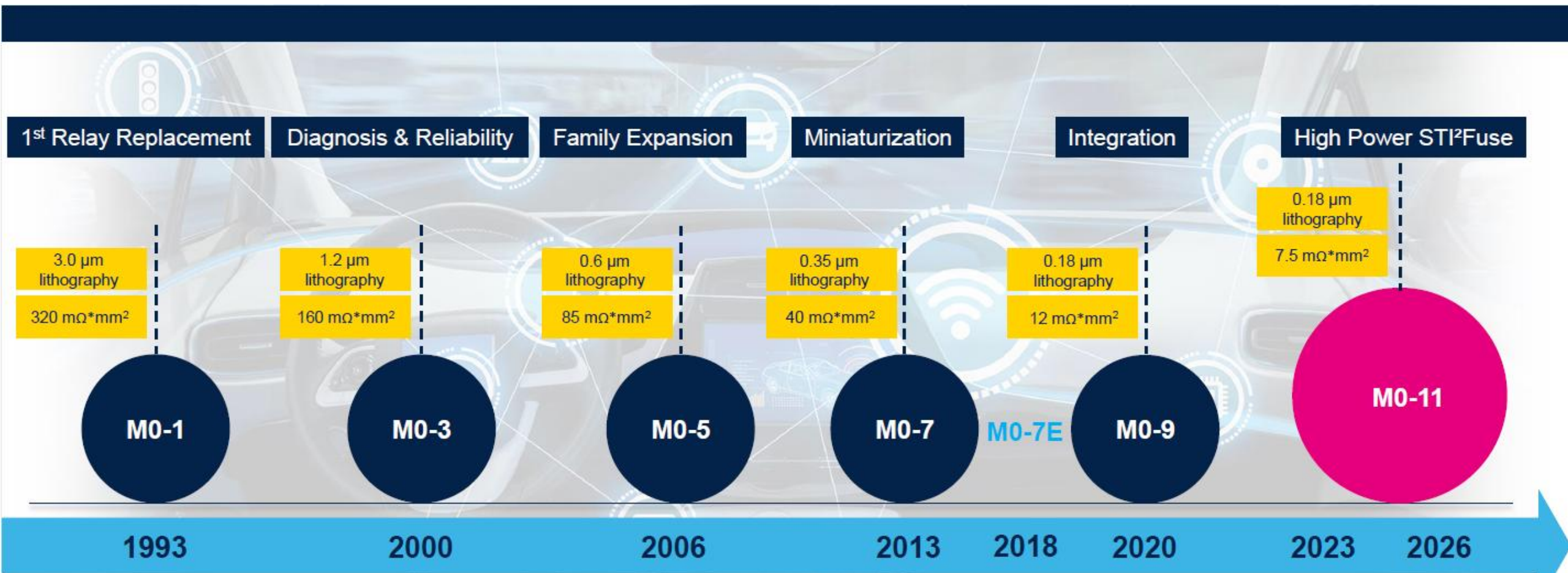



M0-7 Technology Platform Product Portfolio

Technology Platform Values

Family Concept
Identical Feature Set

Multi-sense diagnostic for
Enhanced System Safety

- Temperature Monitoring
- Voltage Battery Monitoring
- Output Current Sensing

Superior robustness & Reliability

- Power Limitation
- Flexible Latch-Off Functionality

Small Footprint Packages
65% of products housed in a tiny
PowerSSO-16

...a success story

1 channels



VN7000AY

VN7003AH

VN7003ALH

VN7004CH

VN7004CLH

VN7007AH

VN7007ALH

VN7008AJ

VN7010AJ

VN7E010AJ

VN7016AJEP

VN7020AJ

VN7040AJ(S)

VN7050AJ(S)

VN7140AJ(S)



2 channels

VND7004AY

VND7012AY

VND7020AJ

VND7E025AJ

VND7030AJ

VND7E040AJ

VND7040AJ

VND7E050AJ

VND7050AJ(12)

VND7140AJ(12)

4 channels

VNQ7040AY

VNQ7050AJ

VNQ7E100AJ

VNQ7140AJ

R_{DSon}
1.3mΩ to 140mΩ

M0-7 Standard

- Multiplexed Current Sense
- Full ON- and OFF-state Diagnostics Capability
- Optimized EMI Performance through Enhanced Gate Driver Concept

M0-7 Enhanced

- Superior Current Sense Precision (Precise diagnostic)
- LV124 severe cold cranking pulse immunity





M0-9 Technology Platform Product Portfolio

Technology Platform Values

Lowest on-state resistance
Embedding TrenchFET

Digital DNA
True Analog/Mixed design with embedded CMOS

Reshaping the systems:
"High Power" and "High Intelligence" for innovative system function partitioning

Digitalization of analog IP
Improve accuracy of analog functionalities like current limitation and thermal parameters.

- Add Serial Interface
- Add advanced digital functionalities

The Lowest on-state resistance & Digital DNA (Trench-FET and embedded CMOS)



M0-9 SPI

- Digital Current Sense & Integrated PWM generation and sampling synchronization unit
- All comes in a footprint up to 42% smaller than the best competitor
- AUTOSAR Complex Device Driver M0-9 SPI (available)

M0-9 Standard

- M0-9 Standard further extends the largest family of HSDs
- Full pin-to-pin and SW compatible with M0-7
- All comes in PowerSSO-16, the benchmark invented by ST

M0-9 family products provides advanced digital features, enabling solutions to help customers make driving safer, greener and more connected





M0-9 SPI high-side drivers

Digital Interface

- 24 Bit ST-SPI ver 4.1
- IC control and diagnostic feedback
- Digital current sensing
- PWM Duty Cycle

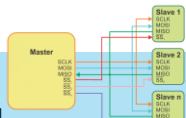

PWM Engine

- 0.1% resolution
- Phase shift
- 400kHz Fallback clock



Limp Home

- OTP input configuration
- Output configuration (OFF/DINx)

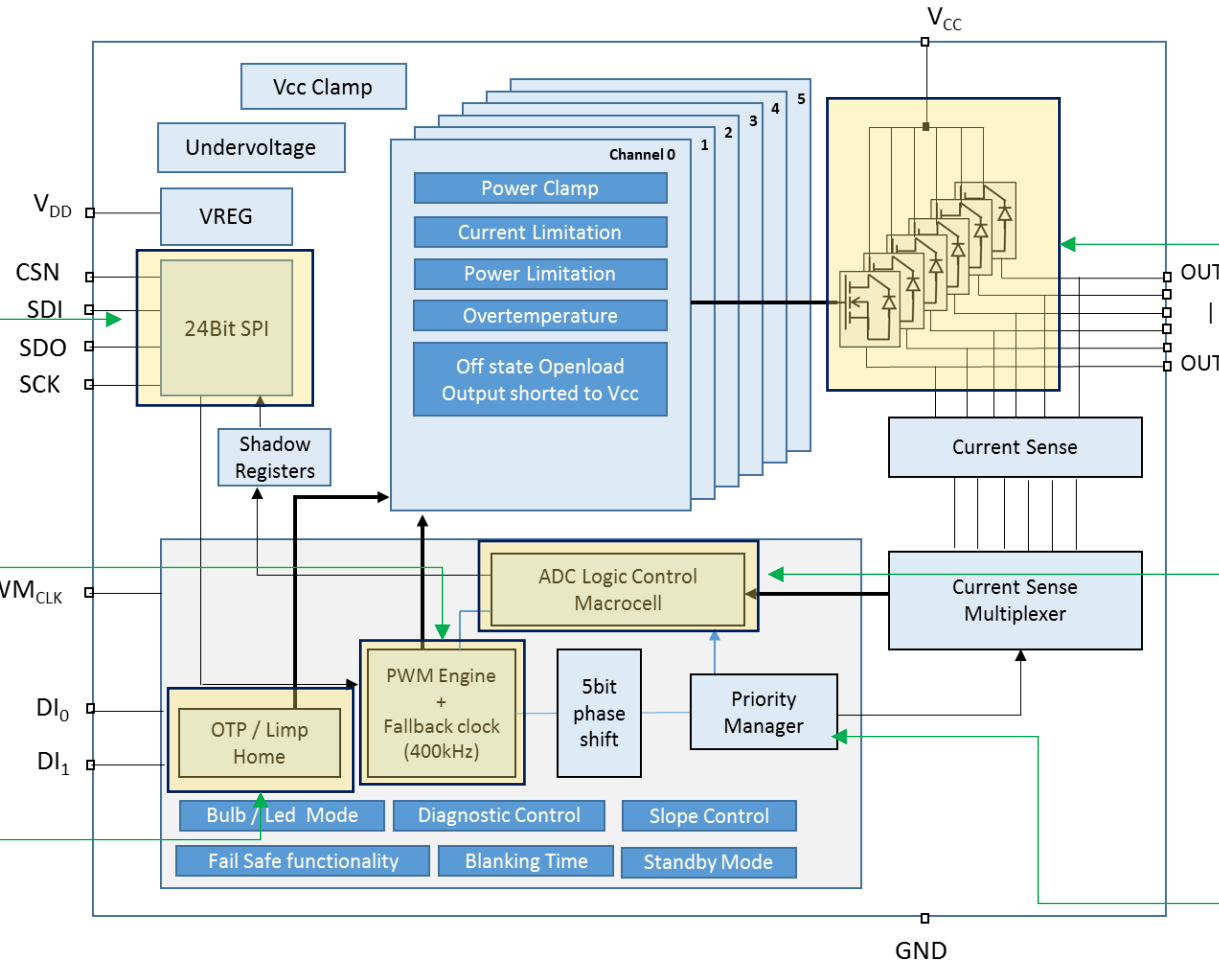

输出功率级 (4 / 6 通道)

- QFN32L 6 x 6
- R_{ds(on)} range : 5mΩ-100mΩ
- Slew rate configurable (4 value)

QFN 6x6



ADC内置

- 10bit resolution
- Error(low current) : (+-) 4LSB
- Error(high current) : (+-) 5%

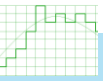

Priority

- Autonomous ADC input multiplexer with task manager sync'd with PWM Engine Channel conversion Arbitration managed by the priority manager unit





M0-9 SPI for BCM optimization

Front & rear corner lights with two devices only

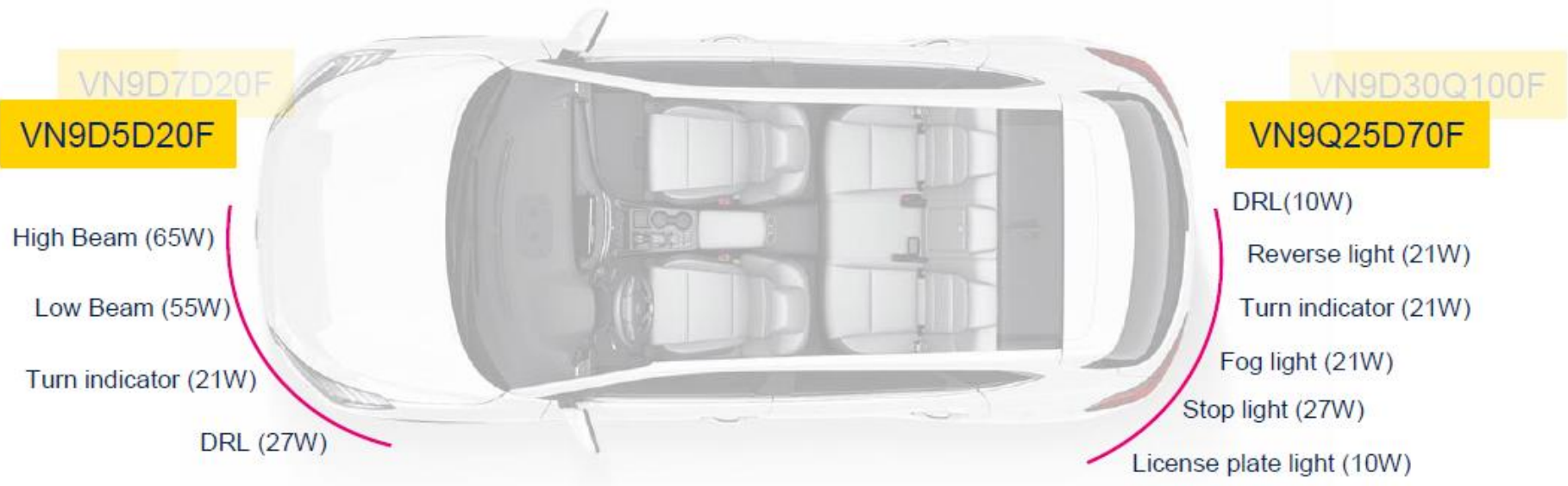

VIPower M0-9 SPI
Competitive advantages

-55% PCB Power-Area
vs Parallel Smart Power

-30% external components

Up to 25% Microcontroller
Workload reduction

-66% Microcontroller I/O and ADC



32 channels BCM based on six M0-9 SPI HSDs



Based on a real partitioning from a main Tier1

Full PCB: 80x120 mm

Power Area: 30x44 mm



24 V Applications

Vehicles with 24 V board net



Trucks



Snow mobiles



Tractors



Boats

LIGHTING

- Exterior lighting:
 - High and Low beam
 - Fog lights
 - Rear and braking lights
 - Turn indicators
 - Flashing lights
- Interior lighting
- Flashing lights
- Metering clusters

OTHER APPLICATIONS

- Electric Motors
- Valves
- Oil / water pumps
- Heaters



VIPower 24 V product family includes single- and dual- channel devices



Part number	Package	Number of channels	Operating voltage range	On-state resistance $R_{DS(on)}$ typ (m Ω)	Drain current limit (I_{LM}) typ (A)	Current sense
VND5T100AJ-E	PowerSSO-12	2	8 to 36 V	100	22	•
VND5T100LAJ-E	PowerSSO-12	2	8 to 36 V	100	22	Optimized for LED applications
VND5T100LAS-E	SO-16N	2	8 to 36 V	100	22	Optimized for LED applications
VND5T050AK-E	PowerSSO-24	2	8 to 36 V	50	34	•
VND5T035AK-E	PowerSSO-24	2	8 to 36 V	35	42	•
VND5T035LAK-E	PowerSSO-24	2	8 to 36 V	35	42	Optimized for LED applications
VND5T016ASP-E	PowerSO-16	2	8 to 36 V	16	60	•
VN5T016AH-E	HPAK	1	8 to 36 V	16	67	•
VN5T006ASP-E	PowerSO-10	1	8 to 36 V	6	84	•

VIPower™ M0-5T HIGH-SIDE DRIVERS PART NUMBERING SCHEME

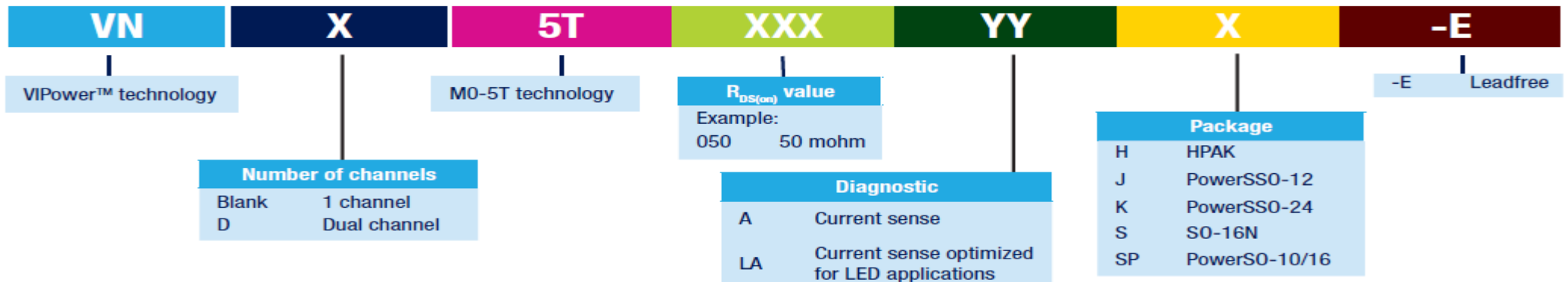

TwisterSIM

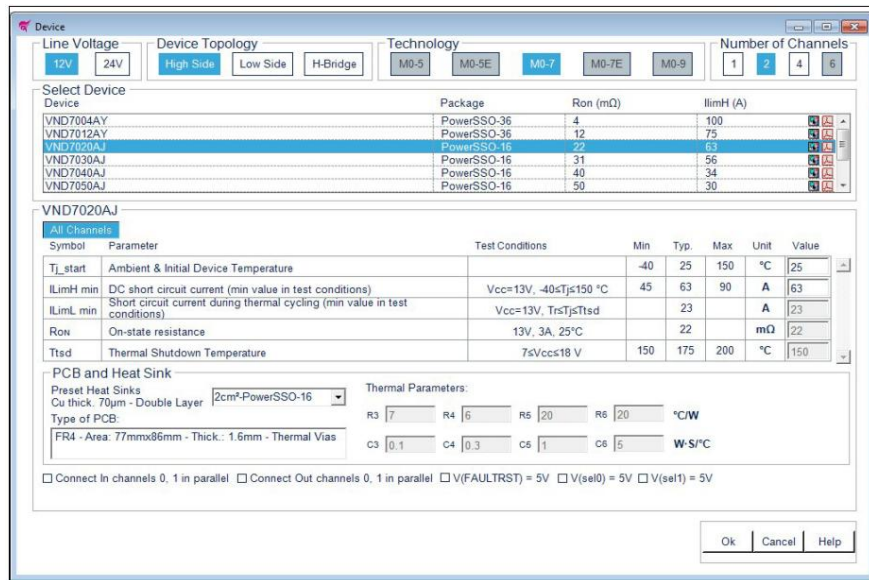
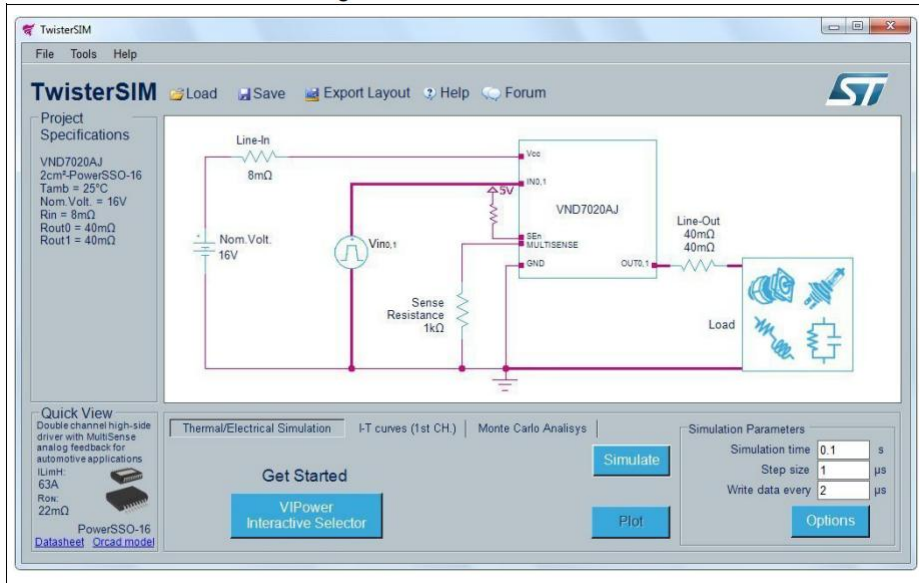

VIpower[®] Interactive Selector

Select the **proper** device for your application in **few clicks**

Supported devices:
 -High/Low side drivers
 -Integrated H-bridges

Electro-Thermal Simulator

Run electro-thermal dynamic simulations to fine tune device selection and understand in detail device behaviour in target application



Two tools in a single package

Unique Tool in Market Place Easy To use

ST Engineers experience available on st.com

STi²Fuse



STi²Fuse - Programmable fuse current & peak current

- VNF9Q20F – SPI Monolithic**
4x 20 mOhm - QFN 6x6
- VNF9D10F – SPI Monolithic**
2x 10 mOhm - QFN 6x6
- VNF9D5F – SPI Monolithic**
2x 5 mOhm - QFN 6x6
- VNF9S0M7Q - SPI Hybrid**
1x 0.7 mOhm
PQFN 7 x 8.5 Dual Die - Clips
- VNF9D1M5Q - SPI Hybrid**
2x 1.5 mOhm
PQFN 7 x 8.5 Dual Die - Clips
- VNF9D2Q – SPI Hybrid**
2x 2 mOhm
PQFN 7 x 8.5 Dual Die - Clips
- VNF9D3Q – SPI Hybrid**
2x 3 mOhm
PQFN 7 x 8.5 Dual Die - Clips
- VNF1x48F – Controller for external Mosfet** - QFN 5x5

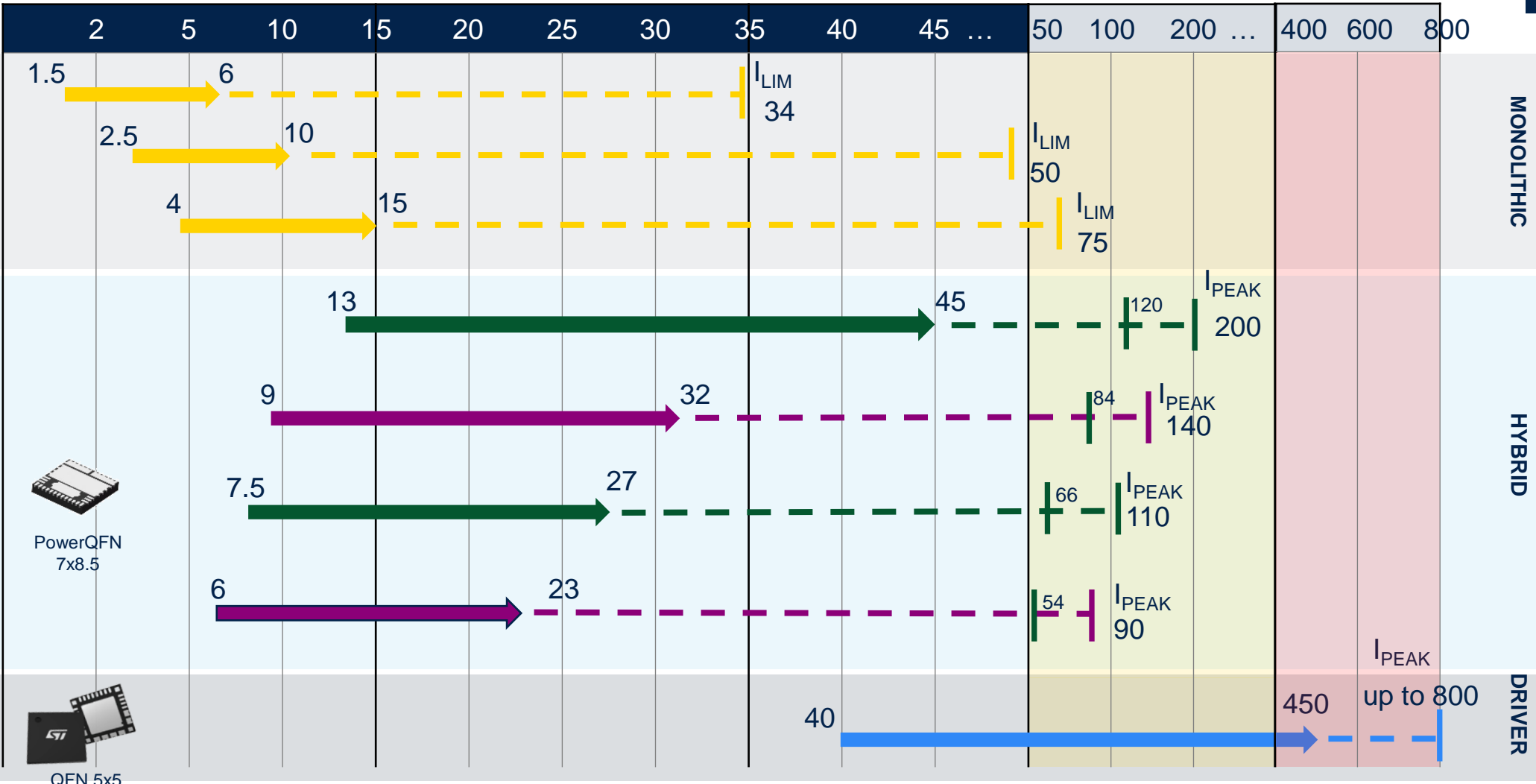

(*) Specified according to AECQ-100-012 (5µH inductive output cable)

Programmable Fuse Current Range – Nominal Current
 Current Protection – I_{LIM} and I_{PEAK} (*)





STi²Fuse Monolithic HSDs - Single Die Main Features

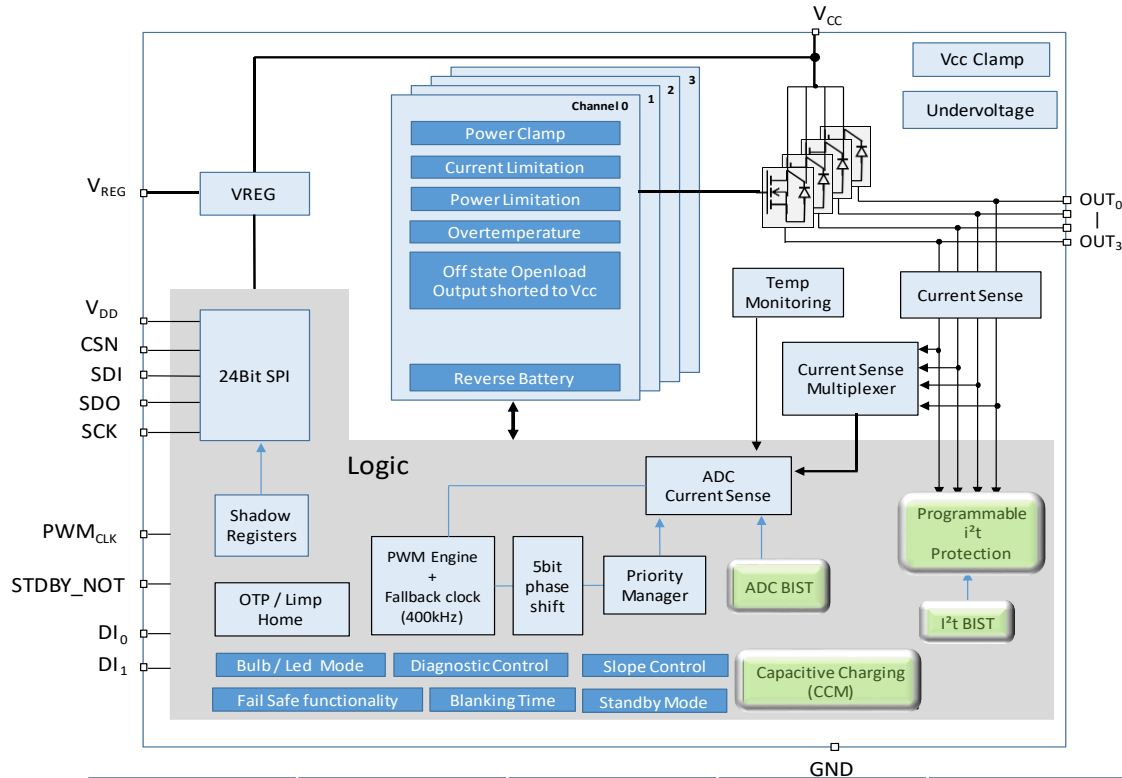

- Dual/Quad outputs with 4 wires ST-SPI interface, pin to pin compatible
 - Possibility to drive the device through Direct Input (also in Normal)
- M09 SPI SW-HW compatible
- Programmable I²t per channel
 - 8 steps for both INOM and TNOM
 - Programmable by both OTP in Fail Safe and SPI in Normal
- Diagnostic of overload, short to GND, Output shorted to Vcc and OFF-state open load
- Overtemperature pre-warning (3 thresholds)
- Capacitive Charging Mode available in both Normal & Fail Safe
- ADC & i²t Self Test at POR
- Failsafe state if Backup Logic is present
 - Two Direct Inputs driving outputs (programmable assignment)
- Failsafe state if Backup Logic is NOT present
 - Outputs state set ON or OFF by OTP
 - Direct Inputs are assigned to "i²t status" and "i²t unlatch" pin
- ISO26262 READY: FMEDA and Safety Manual

DEVICE	RDSON	INOM	TNOM	ILIM
VNF9D5F	2x 5mΩ	4A...15A	300s...1s	75 A
VNF9D10F	2x 10mΩ	2.5A...10A	300s...1s	55 A
VNF9Q20F	4x 20mΩ	1.5A...6A	300s...1s	34 A



* Engineering sample available



M09 SPI **HSD**

硬件兼容

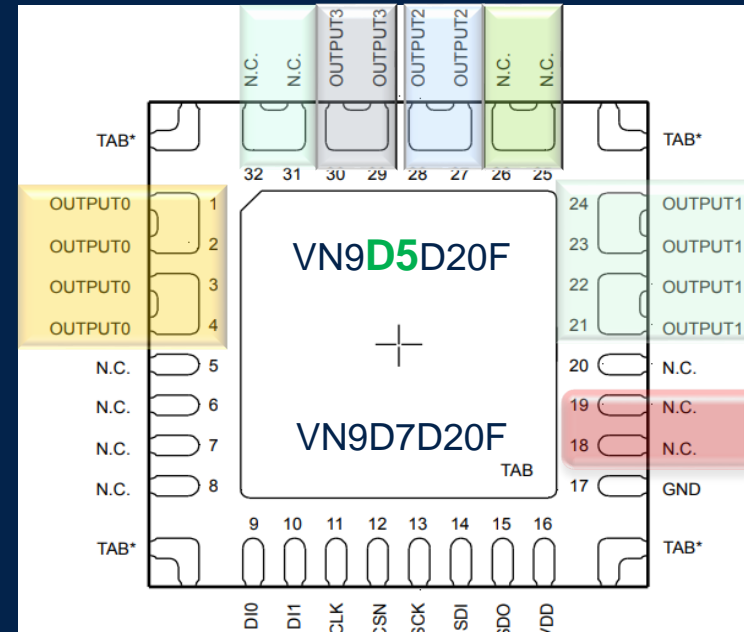
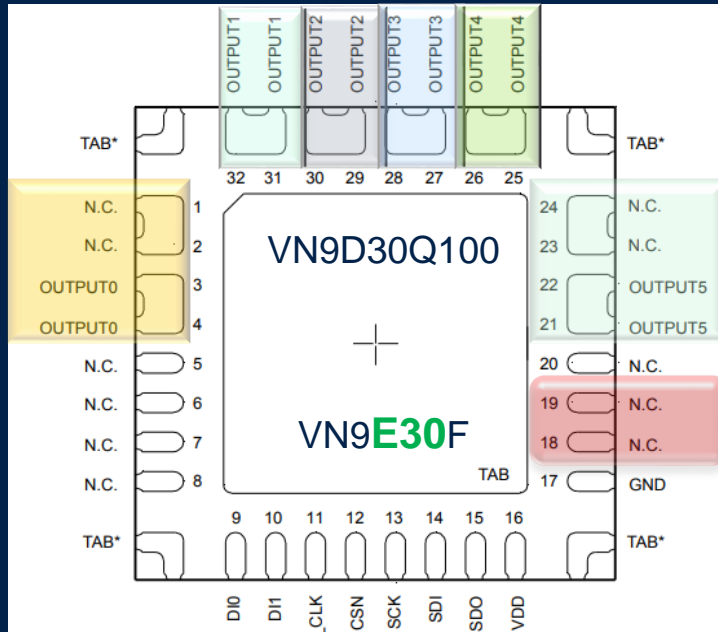

M09 SPI **STi2Fuse**

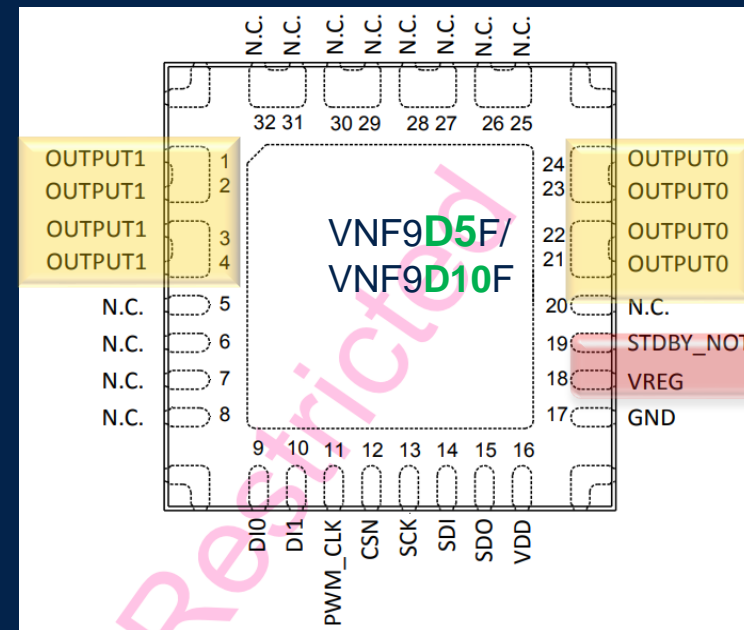
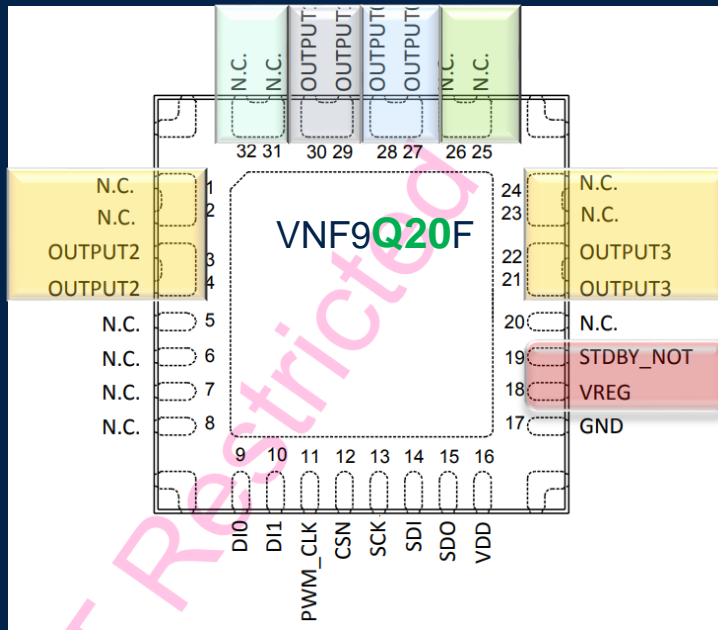



STi²Fuse Controller–VNF1048F / VNF1248F

Main Features

Block Diagram

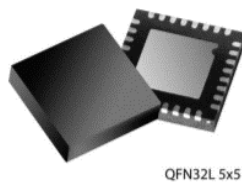
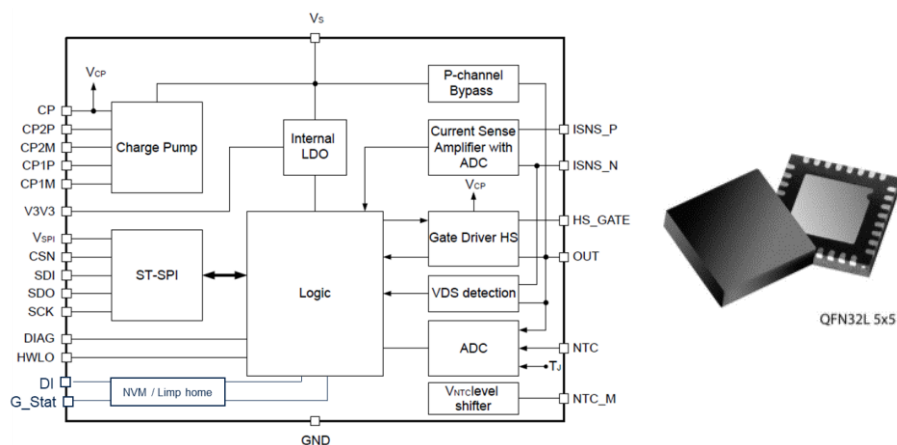

Typical Application Schematic

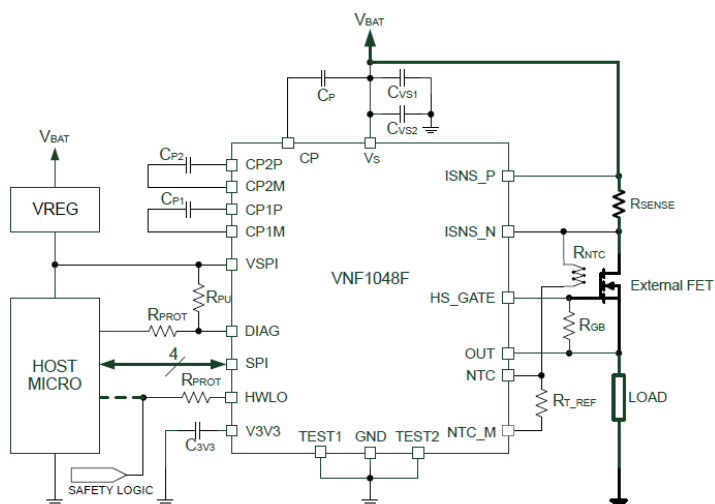

VNF1048 - Main Features

- High Side Switch Control IC with i2t protection for Automotive 12V, 24V and 48V applications
- Gate driver for an external MOSFET in High Side configuration
- Interfaced to a host microcontroller through a 3.3V and 5V CMOS compatible SPI interface
- Integrated P-channel to manage the Stby_ON – typ out current is 200mA
- High accuracy (3%) Digital Current sense through an external high side shunt resistor
- Input for a NTC resistor to monitor the external MOSFET temperature
- Digital TJ, VNTC, VOUT and VDS monitoring through dedicated ADC

Protections:

- Battery under-voltage shut down
- External MOSFET desaturation shutdown configurable via SPI
- Hard short circuit latch-off configurable via SPI
- I2-t curve configurable via SPI
- Device Over-Temperature shutdown
- External MOSFET Over-Temperature shutdown

VNF1248 - Extra Features

- Possibility to drive the device through Direct Input (also in Normal)
- Stby_ON: P-channel 3 times bigger to achieve 600mA as typ out current vs 200mA
- Limp home management: NVM for failsafe state and Direct Input
- Capacitive Charging Mode (CCM)
- Battery u-cut LV124 compatible

Smart P-Channel – L99SP08FTR

For Standby ON - Low power consumption application

Block Diagram

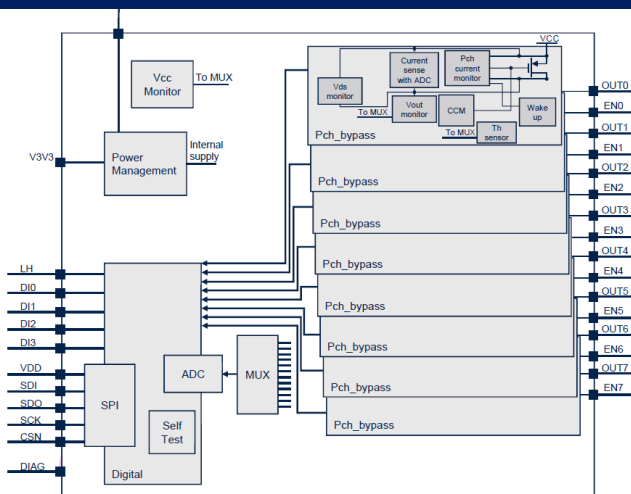

Typical Application Schematic

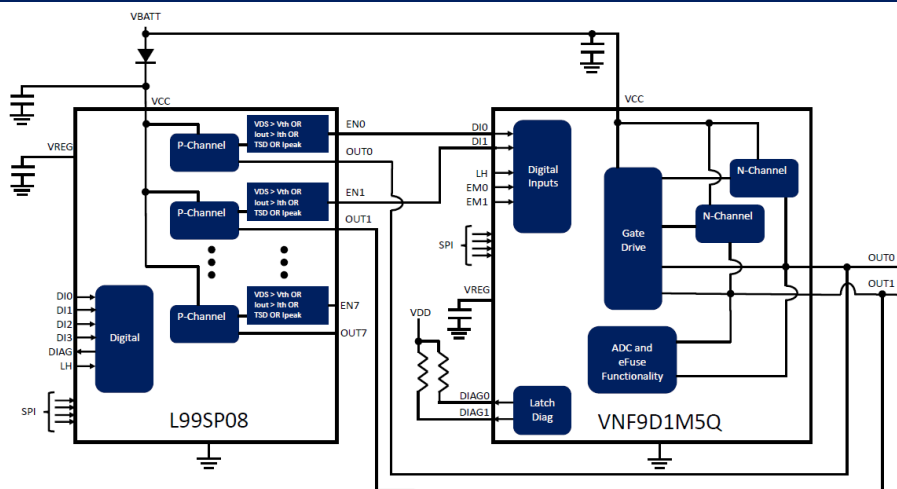

L99SP08FTR - Main Features

- Current consumption in standby-on: <math>< 10\mu\text{A}</math> (x channel, including main switch leakage).
- Typical R_{on} (@room temp): 850 m Ω .
- Programmable current threshold (NVM) to automatically exit the standby-on state generating the EN signal for the main switch.
- Capacitive charging mode in normal operation through current generator: target is 330uF charged in 200ms.
- Limp home mode set by dedicated LH pin.
- 5mA current sense accuracy and case temperature sensing.
- Protections: current & overtemp shutdown, whose triggering generates main switch EN.
- Diagnostic: available on demand.
- ADC Self Test.
- QFN32L 5x5 package.
- Eco-Sustainability Label: Planet-friendly application.



Multi-Channel Switches (Automotive 12V, 24V and 48V)



Multi-channel driver application coverage

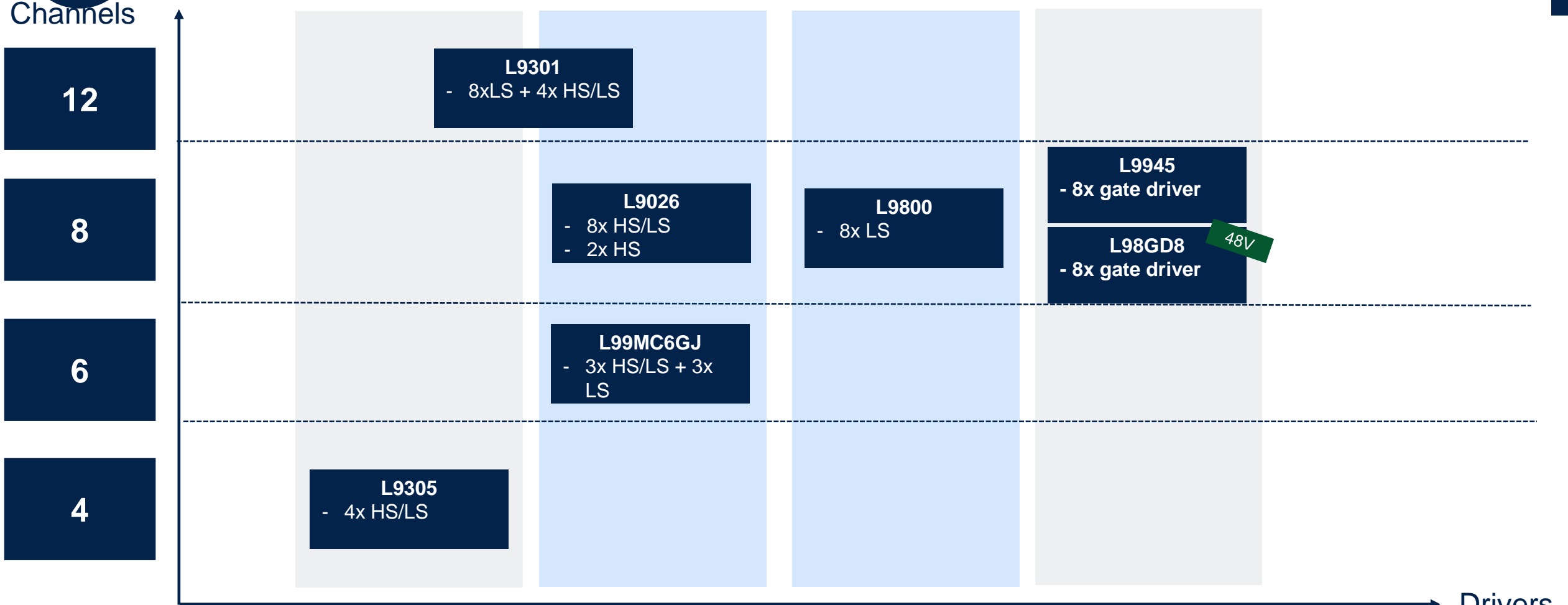

HS/LS drivers with Current Regulation
Valve driver

HS/LS configurable drivers
Bulb LED Relay

LS drivers
Bulb LED Relay

Pre drivers
Bulb LED DC motor

In production
 In development





L9026 overview

Configurable 2 high side + 6 low side / high side IC



AEC-Q100

ASIL-B system ready



Main features

- 6x HS / LS config drivers + 2x HS drivers [Ron typ 700 mΩ]
- Cranking compatibility down to VBATT = 3 V
- Digital supply voltage compatible with 3.3 V and 5 V MCU
- 12 μA quiescent current
- 2x internal PWM generators
- Daisy chain capability SPI, compatible with 8-bit SPI devices
- Limp Home mode [with usage of IDLE and IN pins]
- **NRES and DIS pin in QFN32 package to improve safety**

Protection and diagnostics

- Embedded reverse battery protection on VBATT
- Bulb Inrush Mode [BIM]
- OVL and OVT
- Open load at ON

Applications

- LEDs, relays, and small bulbs
- Body control module
- HVAC and climate control

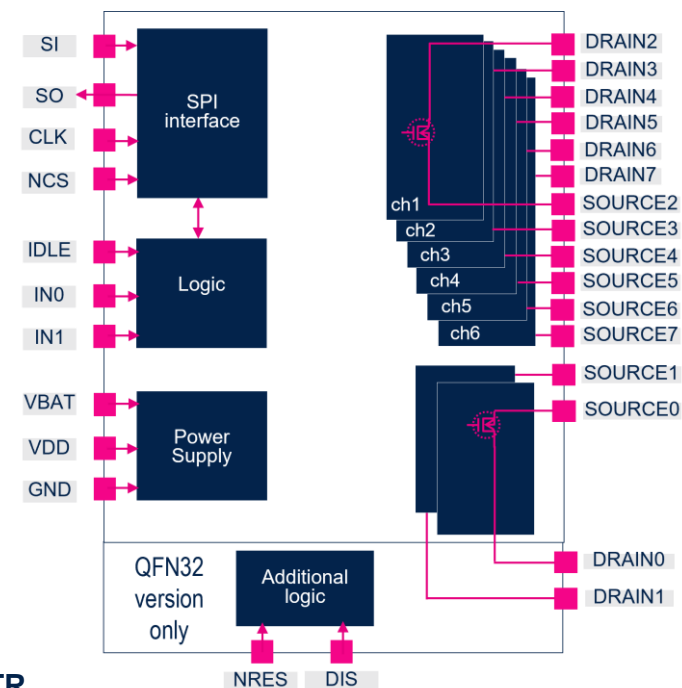

L9026-B03N-TR



VFQFPN32
5x5x1mm

L9026-YO-TR

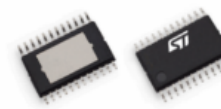

HTSSOP24
7.8x6.4x1mm

OVT: Overtemperature
OVL: Overload





L9800 main advantages

Highly flexible solution | Supports various loads, including LEDs, relays, and small bulbs.

Compliant with **ISO 26262 safety standards**

A highly integrated solution that saves board space, reduces BOM, and simplifies external connections

Limp Home mode guarantees operation even in the event of a main MCU failure



L9800 overview

8-channel low-side driver for 12V automotive applications



AEC-Q100

ASIL-B system ready



Main features

- 8x LS drivers (R_{ON} : 700 m Ω (typ.))
- **Cranking** compatibility down to **V_{BAT} = 3V**
- Digital supply voltage compatible with **3.3 and 5V** MCU
- **<1 μ A** quiescent current
- **2x internal PWM generators**
- **Daisy Chain capability SPI**, compatible with 8-bit SPI dev
- **Limp Home mode** [with usage of **IDLE** and **IN** pins]
- **NRES** and **DIS** pin to improve safety

Protection and diagnostics

- **Bulb inrush mode** [BIM]
- Reverse battery protection on V_{BAT} without external components
- OVL and OVT and open-load protection at ON

Applications

- LEDs, relays, and small bulbs
- Body control modules
- HVAC and climate control

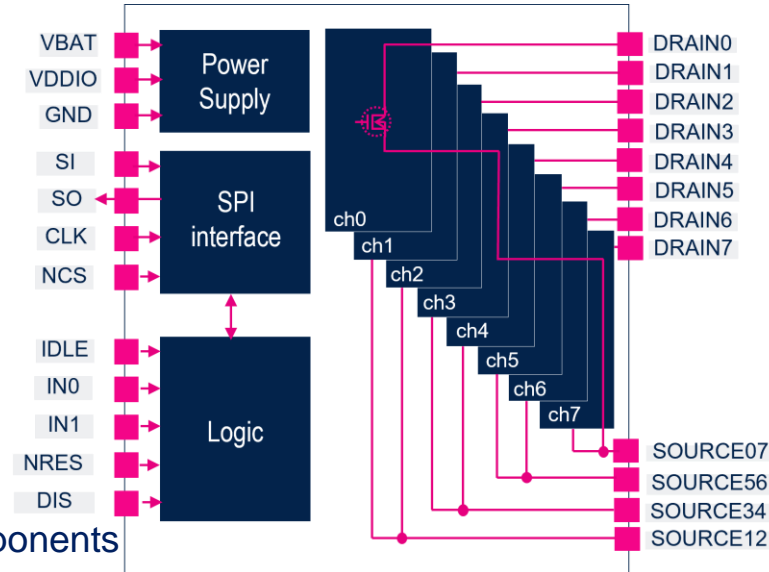

TFQFN24 4x4x0.9mm

OVT: Overtemperature
OVL: Overload



L9301 | Product overview

12 - Channel configurable HS/LS driver



AEC-Q100



Main Features

- 4x HS/LS config drivers [600 mΩ, max 3A]
- 4x LS drivers [600 mΩ, max 3A]
- 4x LS drivers [300 mΩ, max 3A]
- Operating **supply voltage 5V to 18V**
- Digital supply voltage compatible with **5V** microcontroller
- **8x** PWM inputs for each outputs
- Output voltage clamping 37 V typ. in low-side configuration

Protection and Diagnostics

- OVT, OVC and shutdown protection
- SPI for diagnosis data communication
- Clock monitor

Applications

- Suspension system
- Transmission system
- Body control module



PowerSSO-36

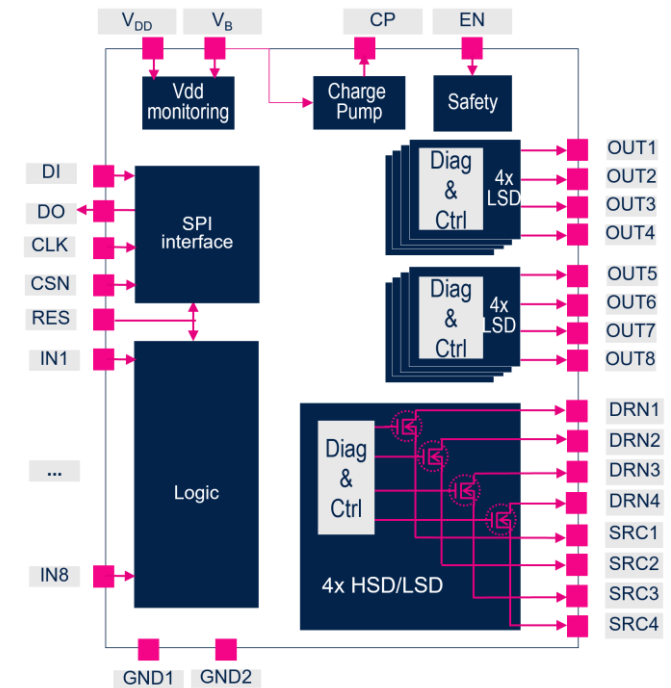

OVT: Overtemperature
OVC: Overcurrent





L9945 | Key features

Flexibility: It is designed to comply with the requirements of 12 V [passenger vehicle] and 24 V [commercial vehicle] battery systems.



High Configurability: the device can be configured as High-side, Low-side, H-bridge [up to two H-bridge], Peak&Hold.





L9945 | Product overview



AEC-Q100

8-channel fully configurable MOSFET pre-driver complying with 12 V and 24 V battery systems



Main Features

- Operating supply voltage **3.8V to 36V**
- Operating **VDD** supply voltage **4.5V to 5.5V**
- **8x LS** drivers
- **8x HS** drivers
- **2x H-Bridge** drivers
- **2x Peak & Hold**
- All output controlled through parallel PWM inputs.

Protection and Diagnostic

- Overcurrent monitoring
- Current limitation for H-bridge
- Full diagnostic for short circuit to battery, open load, short circuit to ground for each individual output

Application

- Body control module
- Engine management systems
- Air conditioning

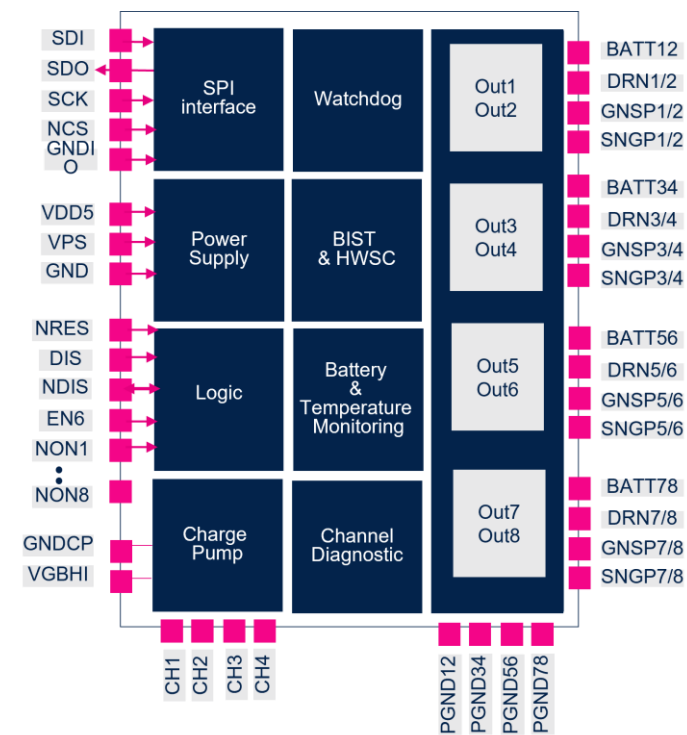



L98GD8 | Key Features

Flexibility: It is designed to comply with the requirements of 24V up to 48 V (commercial vehicle) battery systems.

High Configurability: the device can be configured as High-side, Low-side, H-bridge (up to two H-bridge), Peak&Hold.



L98GD8 | Product Overview

8-channel fully configurable MOSFET pre-driver complying with 12V, 24V, 48V battery systems

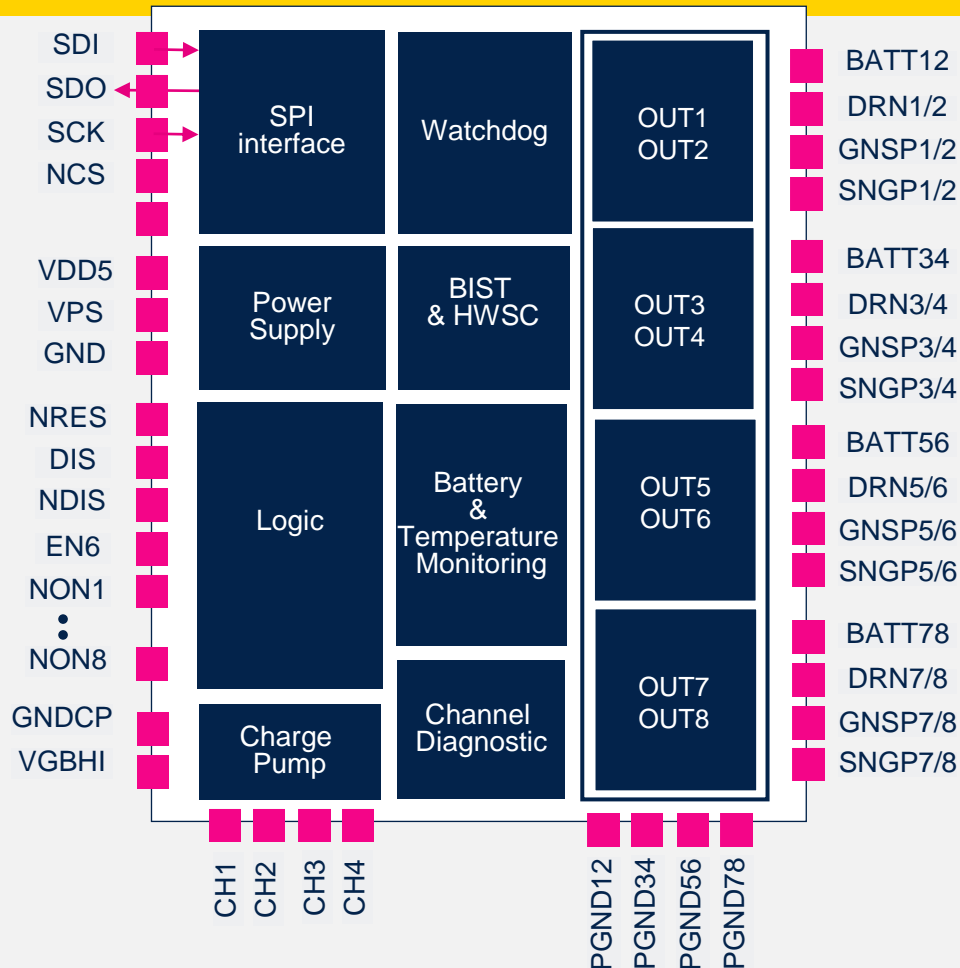

Main features

- Operating battery supply voltage 3.8V to 60V
- Operating VDD supply voltage 4.5V to 5.5V
- Up to 8x High Side Drivers
- Up to 8x Low Side Drivers
- Up to 2x Peak & Hold
- Up to 2x H-Bridge Drivers
- All output controlled through parallel PWM inputs.

Protections and Diagnostics

- Overcurrent monitoring
- Current limitation for H-bridge
- Full diagnostic for short circuit to battery, open load, short circuit to ground for each individual output
- Each output status can be constantly monitored through dedicated SPI registers
- Highly flexible overcurrent sensing implementation



L98GD8 | Application Case

The device offers three different configuration options for the 8 output channels:

- **High side- Low side:** through a dedicated register of SPI user can choose:
 - 1) **MOS side** (High side or low side)
 - 2) **MOS type** (Nmos and Pmos)
- **Peak & Hold:** requires 2 or 4 channels, There are two possible configurations
 - 1) **P&H1** it involves channels 1 (HS) and 4 (LS)
 - 2) **P&H2** it involves channels 2 (HS) and 3(LS)
- **H-Bridge:** requires 4 or 8 channels. There are two possible configurations.
 - 1) **H-Bridge 1:** it involves channels 1 (HS), 2 (HS), 3 (LS) and 4 (LS)
 - 2) **H-Bridge 2:** it involves channels 5 (HS), 6 (HS), 7 (LS) and 8 (LS)



L98GD8 | Safety Features

8 Ch Pre-Driver Mosfet Suitable for 48V Battery System ICs

Fast switch-off redundant output disable through external pins

Built in Self Test (BIST) for logic operation

Configurable Communication Check (CC) watchdog timer available

Hardware Self Check (HWSC) for VDD5 overvoltage comparator and disable feedback through bi-directional pin

VIPower low-side drivers - OMNIFET families



VIPower low-side drivers OMNIFET families

Market

Conventional

Emerging

Target

Applications



- Relay Drivers
- Injector driver
- Interior Lighting
- Body Control Module



- Safety switch
- Hard contactor Driver
- Battery Management System





VIPower low-side drivers OMNIFET families

OMNIFET

- 60V and 70V voltage clamp
- 28 to 300mΩ
- Single channel only
- 20kHz switching capability
- 5V VIN compatibility
- 3-pin device
- DPAK, D2PAK, TO220, PowerSO10

1st Generation



OMNIFET II

- 45V voltage clamp
- 10 to 250mΩ
- Single and dual channel
- 20kHz switching capability
- 5V VIN compatibility
- 3-pin device
- DPAK, D2PAK, TO220, SO8, SOT-223

2nd Generation



OMNIFET III

- 46V voltage clamp
- 30 to 300mΩ
- Single and dual channel
- 1kHz switching capability
- 5V VIN compatibility
- Dedicated optional diagnostic pin
- SO8, SOT-223, PSSO-12

3rd Generation

From General purpose

to specialized and miniaturized products



VIPower low-side drivers

OMNIFET II and III series overview

Technology Platform Values

OMNIFET II

- 45 V voltage clamp
- From 10 to 250 mΩ
- M03 Technology
- **20 kHz** switching capability
- 3.3V and 5V V_{IN} compatibility

OMNIFET III

- 46 V voltage clamp
- From 30 to 300mΩ
- M05 technology
- 1 kHz switching capability
- 5 V V_{IN} compatibility
- Dedicated optional diagnostics pin

OMNIFET Series Portfolio Overview

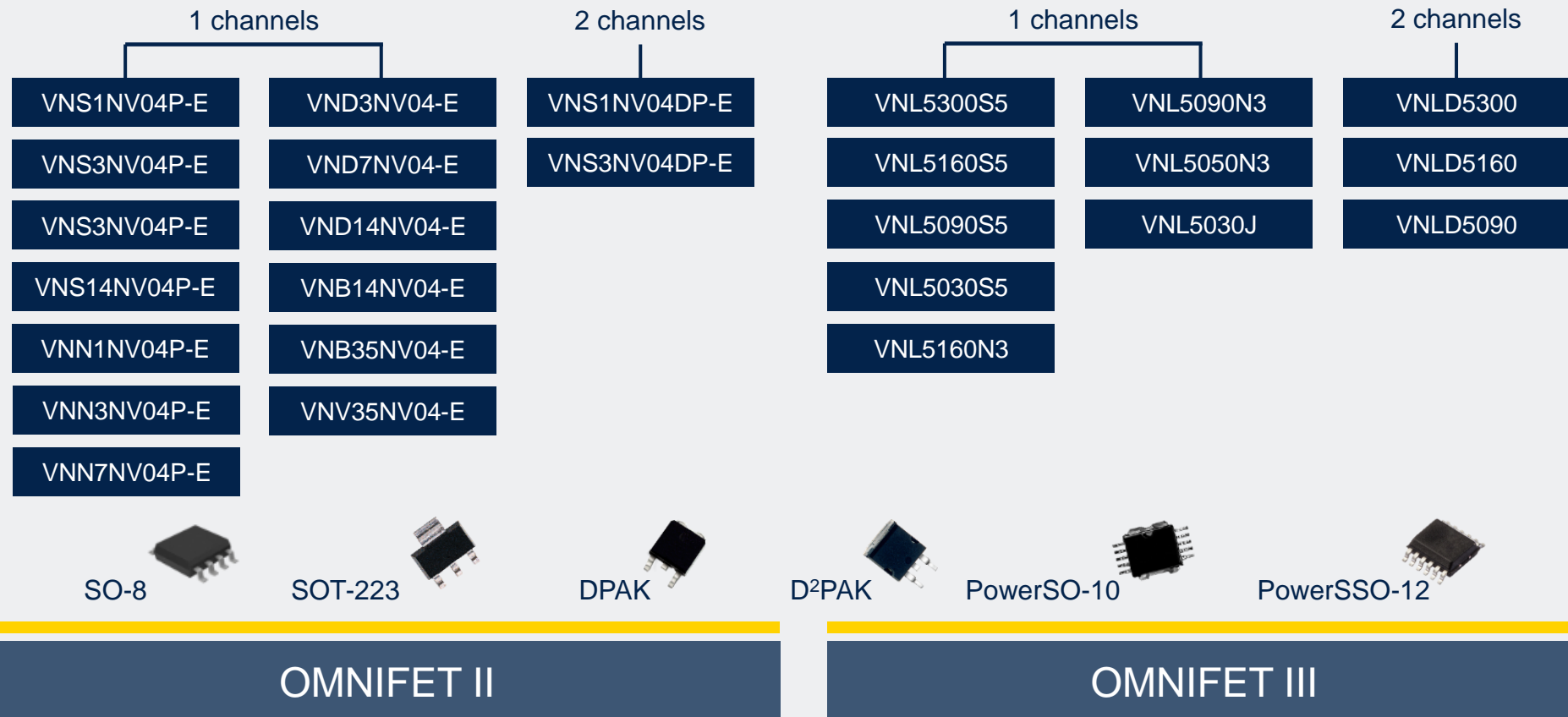



Omnifet III features

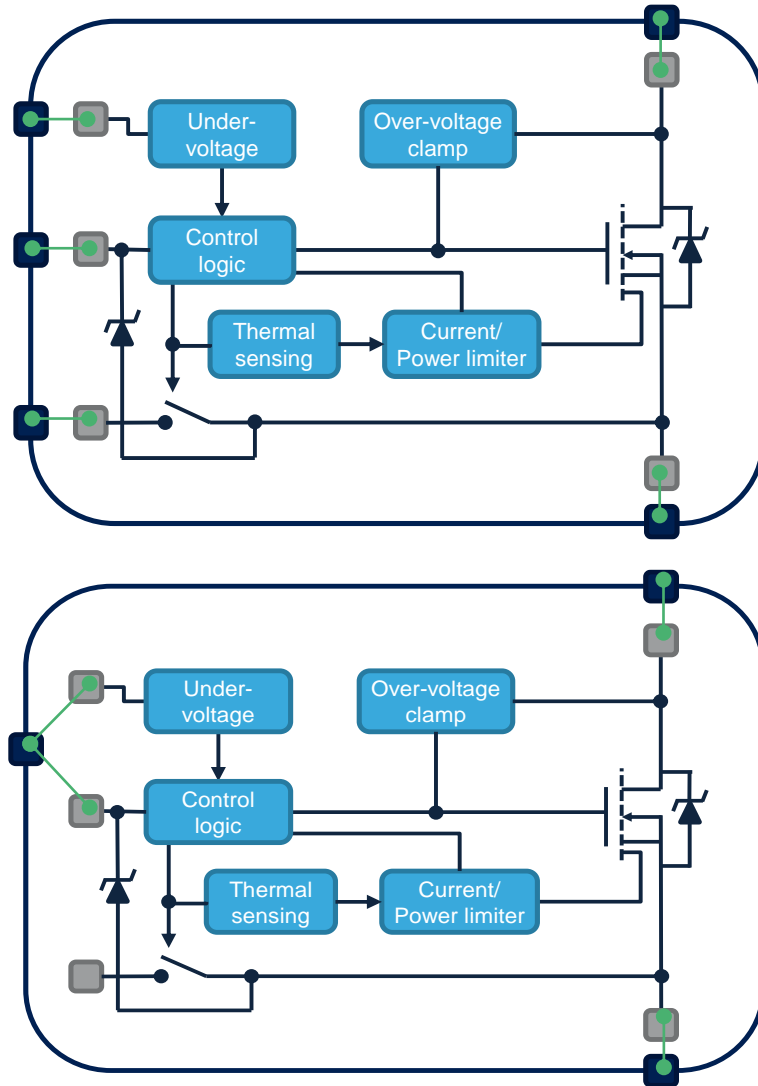

- **Family approach for 10+ part numbers with same feature set concept**

- Different R_{ON}
- Single, Dual channel
- SOT223 and SO-8 as main package

- **Protection features**

- Different current limitation
- Thermal shutdown (auto-restart)
- Over voltage clamp
- Electrostatic discharge protection

- **Diagnostics**

- Status output (for SO-8 package devices)



48V LSD Proposal

Possible Solution

Re-qualification based on our current portfolio

Current portfolio

- VNB10N07, VNB20N07, VNB35N07-E, VND5N07-E, VNP10N07, VNP20N07, VNP35N07-E, VNV35N07-E

$$V_{\text{clamp}} = 70\text{V}$$

Our technology starts with You

© STMicroelectronics - All rights reserved.

ST logo is a trademark or a registered trademark of STMicroelectronics International NV or its affiliates in the EU and/or other countries.

For additional information about ST trademarks, please refer to www.st.com/trademarks.

All other product or service names are the property of their respective owners.

