



# Robotics Segment Strategy: “Bringing KAI to Life” “Sim-to-Real”

Allan Lagasca

Smart Industrials Segment -WW  
Robotics Segment Strategic Program (SSP)

STMicroelectronics

# “System Engineering: A New Mindset, A New Way of Thinking”

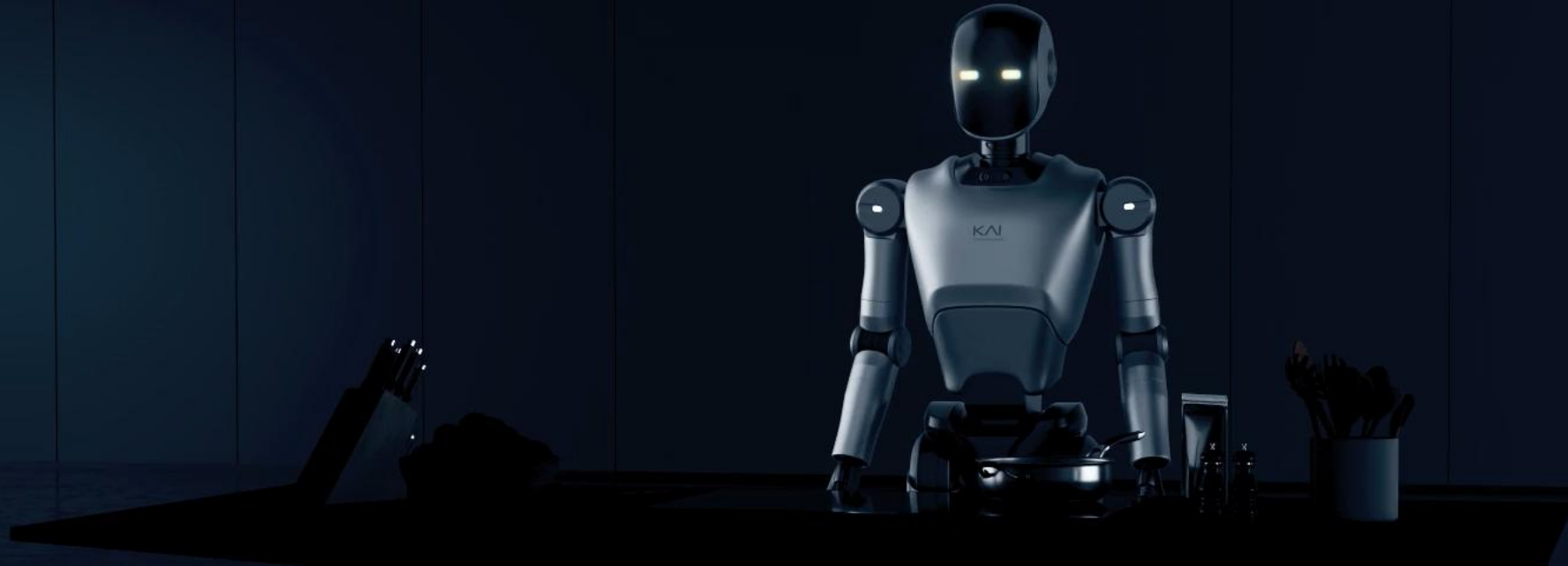

# Robotics: System architecture level

System Engineering is “Speaking the customer’s language”

### Product approach

Functional target: product-fit

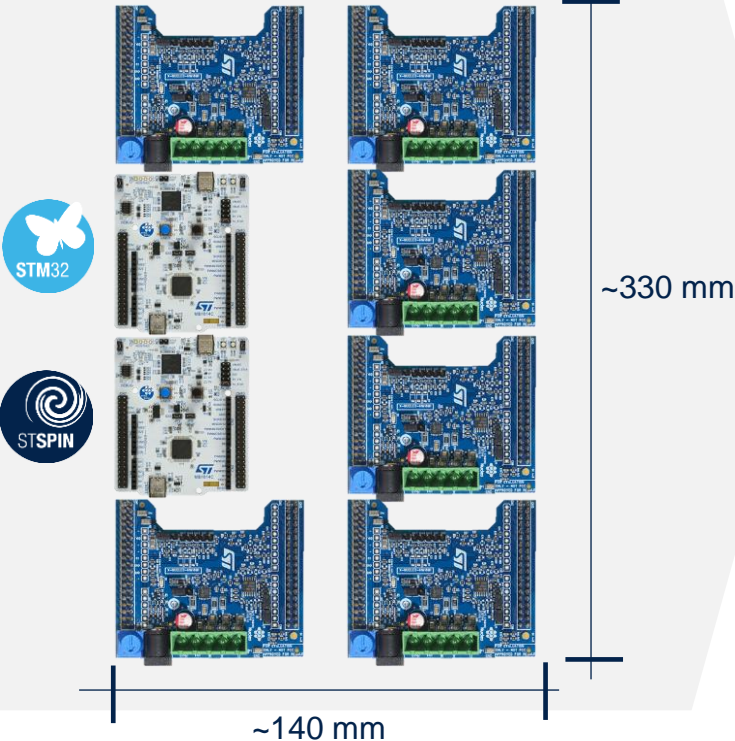

### System engineering

System-level target: perfect-fit

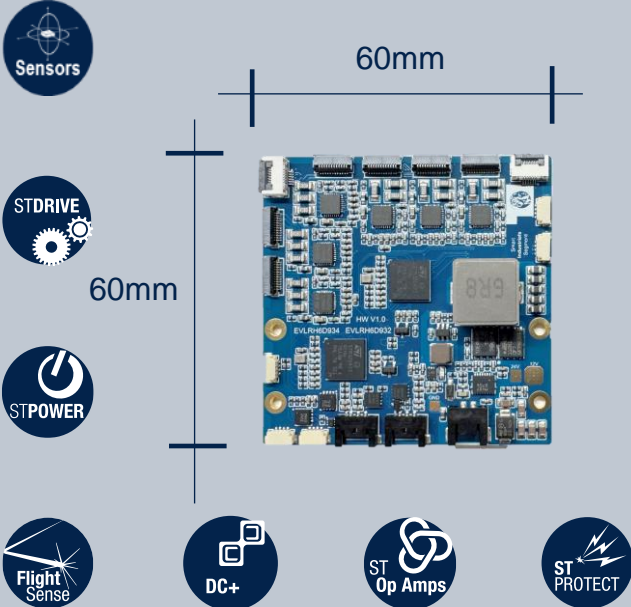

### Customer project

Robot hand 6-Servo (DoF) 60x60 mm

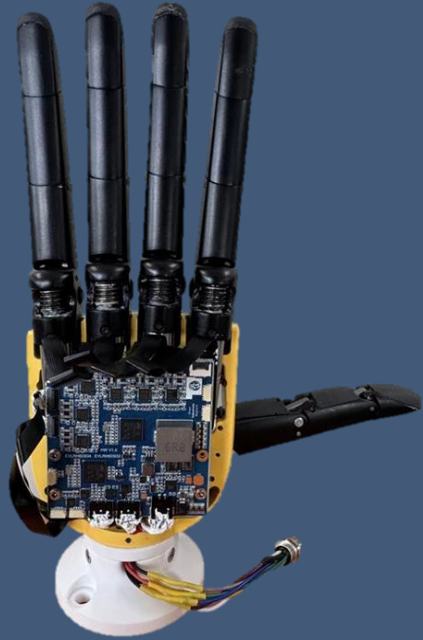

# Robotics: System architecture level

System Engineering is knowing “Customer Challenges”

## System engineering

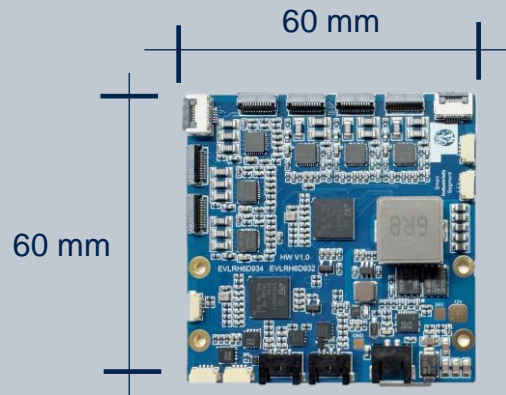

### Customer challenges:

- Longer battery usage- more efficiency
- Multimotor for higher DoF
- Multi-protocol requirements
- High Density, small form factor
- Higher intelligence – edge AI
- More Integration

## Customer robot hand

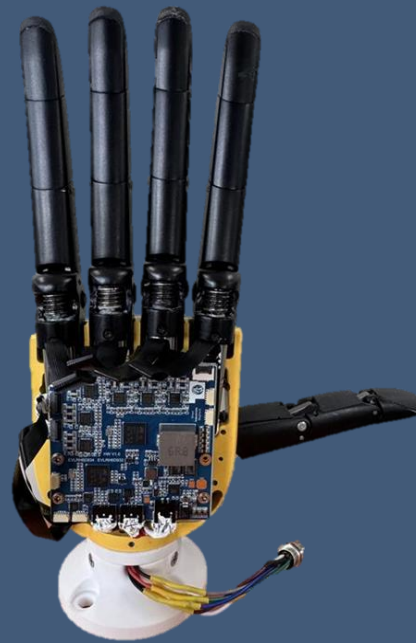

## Product roadmap

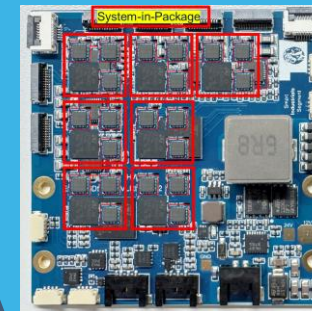

21-servo motor  
system-in-package

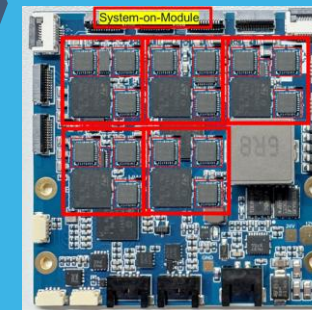

15-servo motor  
system-on-module

# Robotics: System architecture level

System engineering → system architecture → customer

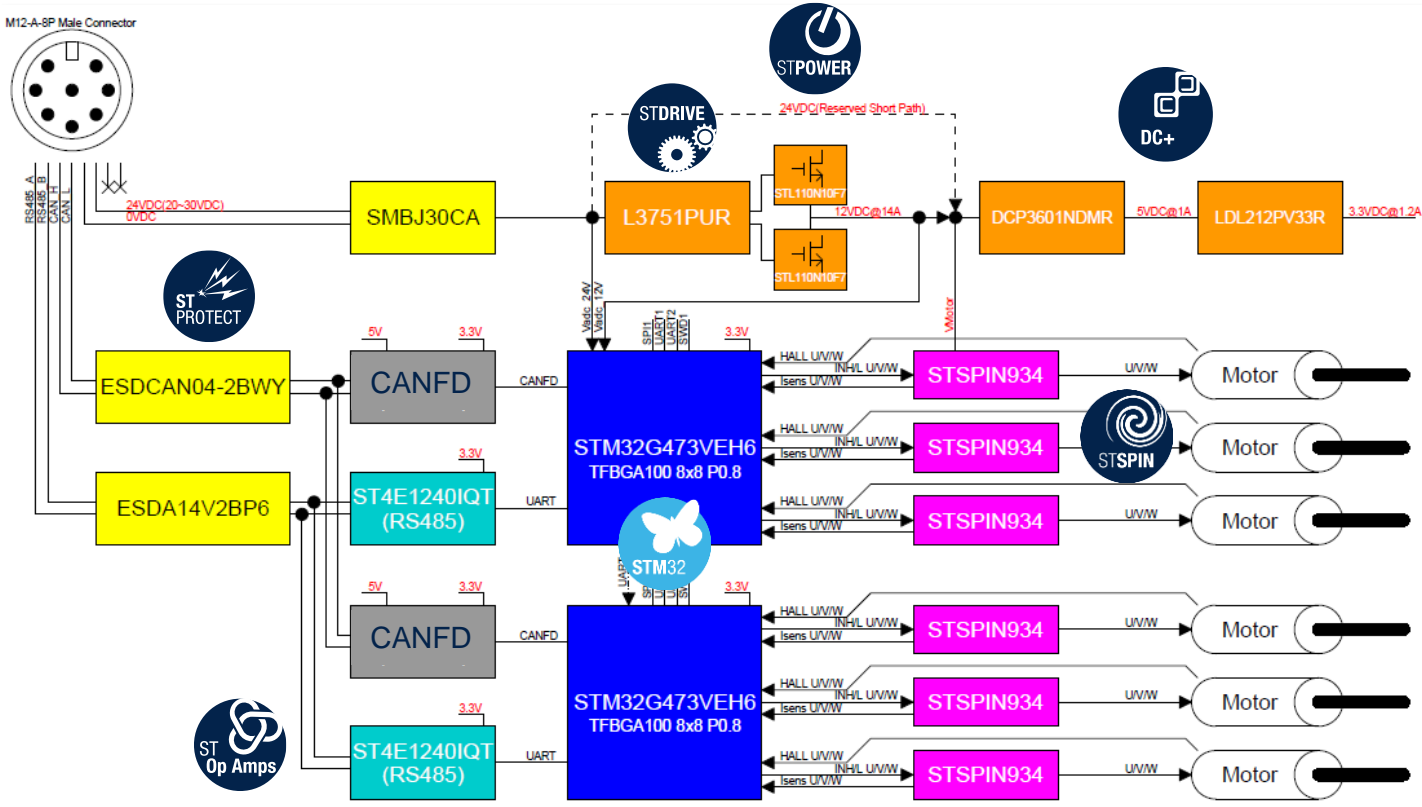

## Customer robot hand

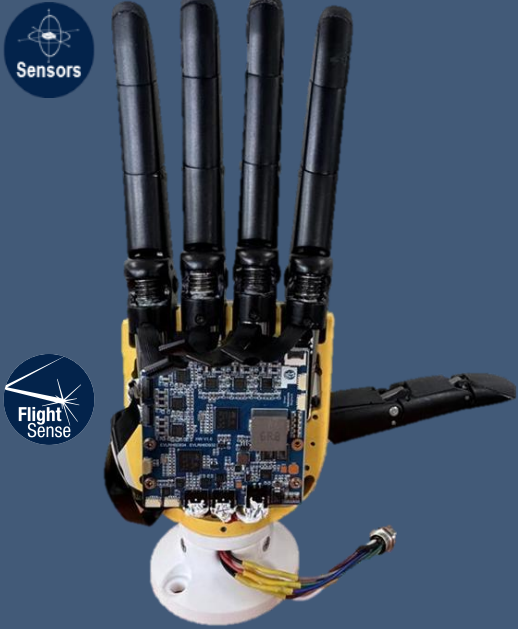

# 6-joint robotic hand solution with AI Gesture recognition

21 finger key points data (X, Y, Z)

PLC data processing

6 servo motors position data



VD66GY Wolfy camera



STM32N6 EVM board

Sensing

LVTTTL

RS-485

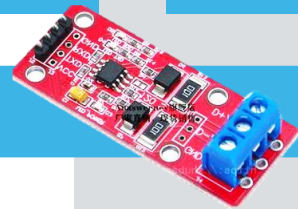

Smart  
Industrials  
Segment

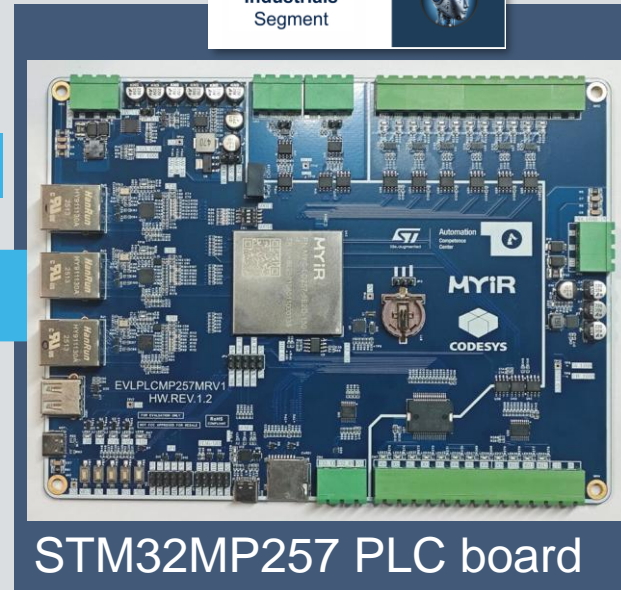

STM32MP257 PLC board

Controlling

CANFD

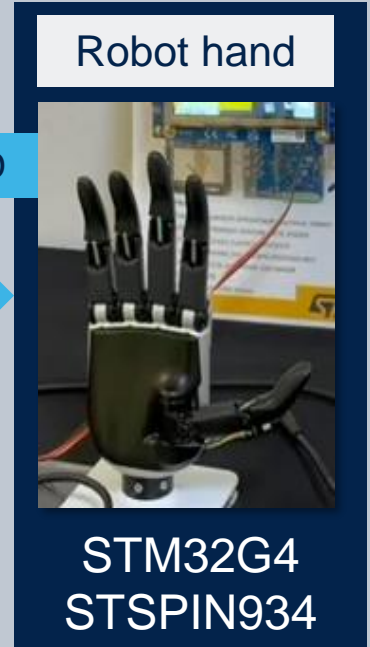

Robot hand

STM32G4  
STSPIN934

Actuating

# 6-joint robotic hand solution ST full turn-key system platform

**Next Upgrades:** Sensors (includes biosensors) and Image processing, 15-servo Robot Hand development and edgeAI (N6).....and more

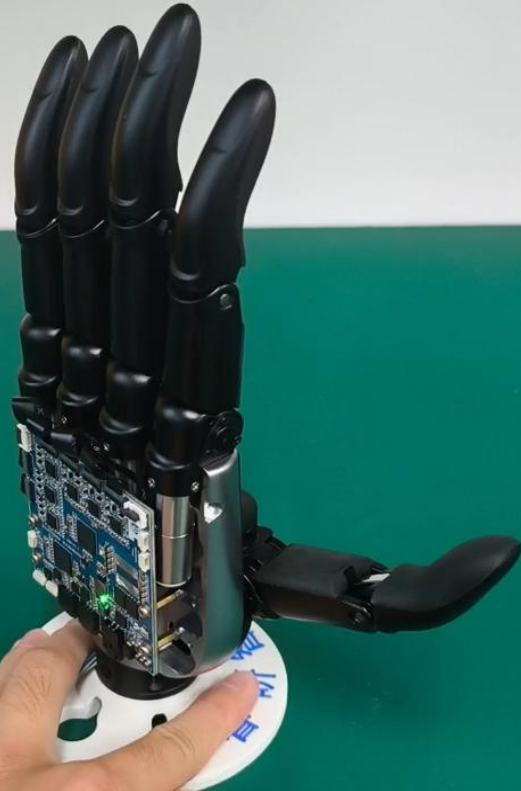

STM32G473VEH6 \*2

DCP3601

LDL212PV33

ST4E1240 \*2

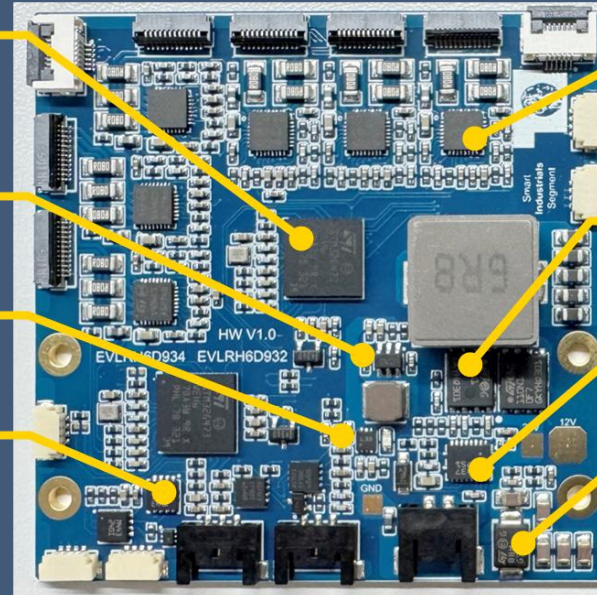

STSPIN934 \*6

STL110N10F7 \*2

L3751PUR

SMBJ30CA

**Partnership: ST is open for Co-Development and Co-Marketing Collaboration**

Contact us to learn more ....



**Posture recognition & voice control solution for KAI half-body robot**

# Half-body humanoid robot Posture recognition and voice control

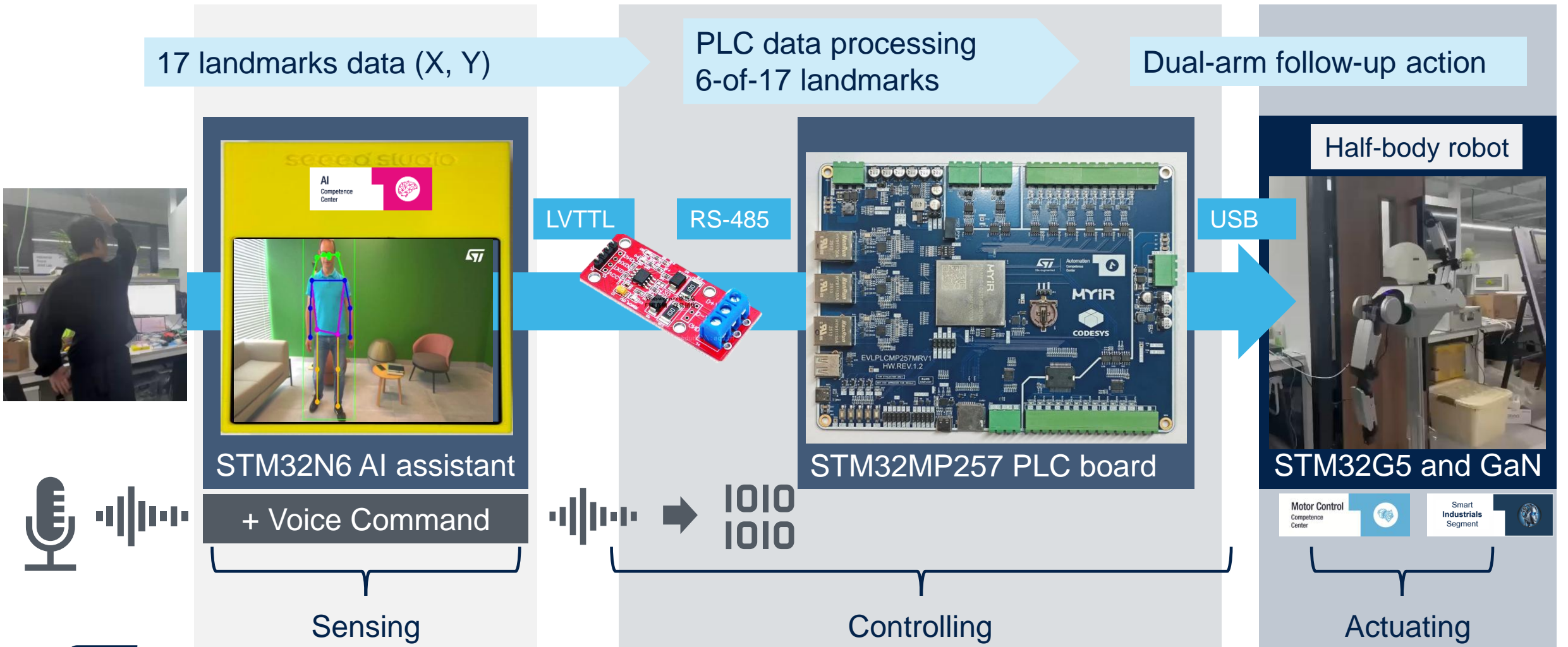

**Additional features in pipeline:** rPPG (vital sign monitoring) using imaging device, biosensors, robot joints, IMU module, proximity sensors for safety, ST60 for 360° rotating head, and for NVIDIA HSB visual demonstration

# ST Robotics Partners model

Partnerships: Co-marketing collaboration and Co-development



Global external events: >100K viewership/yr

A collage of global external events. At the top is the 'eelectronica' logo. Below it are logos for 'CES', 'TECHNO FRONTIER 2025', and 'Robotics & AI DISCOVERY DAY 2025'. The next row features 'SEMICON TAIWAN', 'SEMICON Europa', and 'SEMICON CHINA'. The bottom row includes 'TAIPEI Automation 2025', 'HUMANOIDS 2025' (September 30 - October 2, 2025 • COEX, Seoul, Korea), 'RobotX Innovation Day', 'SENSOR+TEST MESSTECHNIK-MESSE', and 'HANNOVER MESSE ASIA-PACIFIC event'. The text 'And more...' is at the bottom.

All commercial discussions are between the partner and the customer, including customization requests.



# Strategic partnership: bridging the gaps

Enabling robot parts makers for NVIDIA-based platforms

## 2026 Robotics segment plan



Holoscan sensor bridge (HSB)

**Major challenge on compatibility:** NVIDIA Jetson ecosystem via HSB  
The HSB uses FPGA to receive high-bandwidth data, encapsulates the sensor data into Ethernet packets, then transmitted over high-speed Ethernet ports (10Gbps).

### Robot parts elite partners



Elite Partner



Elite Partner



Elite Partner



Elite Partner



Elite Partner



\*Note: Contact us if you want to know more

# ST Robotics: Strategic Positioning Addressing Cybersecurity @ Product and System Level



The EU's Cyber Resilience Act also affects factory and process automation devices, including **sensors, actuators, controllers and communication technologies** – especially those with digital interfaces.

## Guideline of CRA for FA products

### ST Cybersecurity Positioning

Product: Process Certification, Class 1, Class 2

System: IEC62443-4-2 Application Countermeasures

## and Threat analysis

## Threat Analysis on a virtual FA product

## Countermeasures

# ST broad portfolio addressing humanoid robots

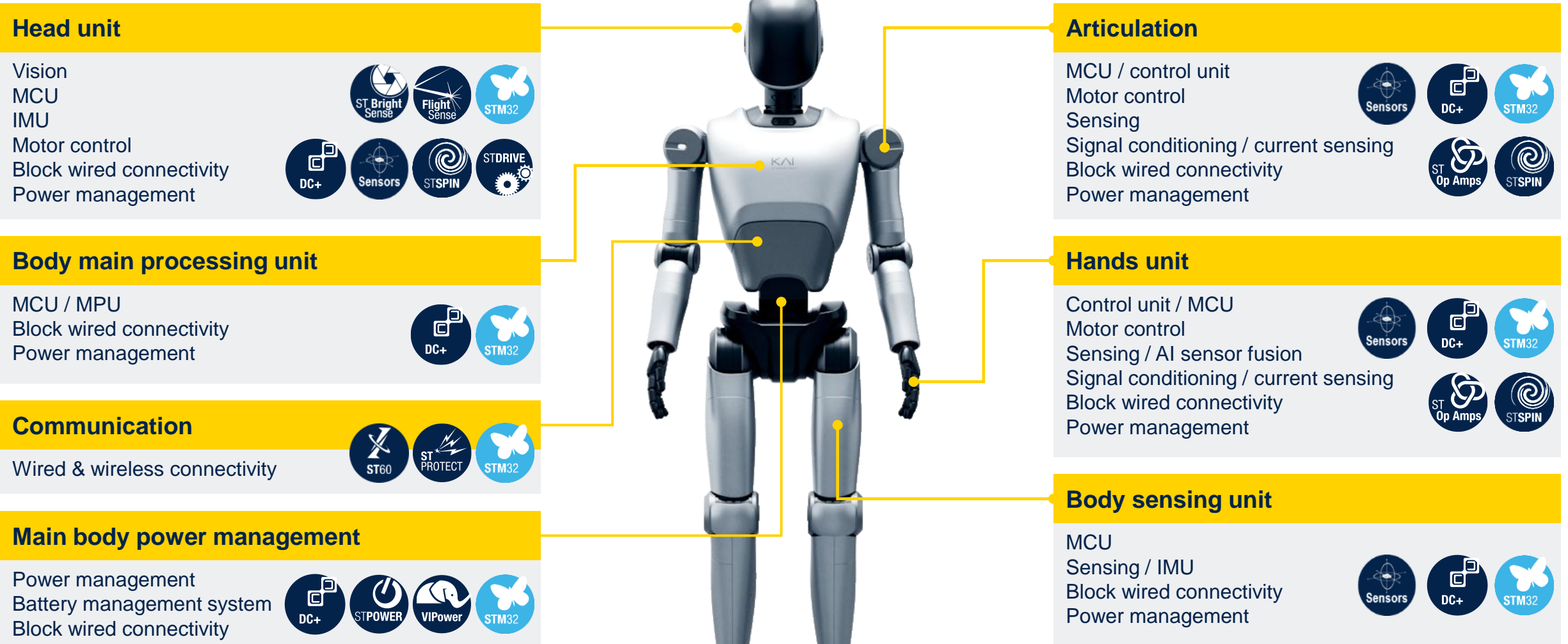

# Robotics Segment Strategy

## “Blue Ocean Market”

“Speak the Customer Language” at System Architecture level

Address Robotics Challenges with turn-key solutions

Differentiated Partnership Strategy: Co-Marketing Collaboration

High-level customer technical intimacy

360° Robotics System Approach



\*Sources: UBS, Gartner, OMDIA, Internet Info, InterACT – estimate based consolidation by Market Intelligence Team

# Our technology starts with You



Find out more at [www.st.com](http://www.st.com)

© STMicroelectronics - All rights reserved.

ST logo is a trademark or a registered trademark of STMicroelectronics International NV or its affiliates in the EU and/or other countries.

For additional information about ST trademarks, please refer to [www.st.com/trademarks](http://www.st.com/trademarks).

All other product or service names are the property of their respective owners.

