



Bridgeless totem-pole PFC solutions

2kW 3-ch Interleaved ZVS



3.6kW with in-rush current control



2.5kW GaN based



Power Technologies



2kW 3-ch interleaved totem pole ZVS-PFC

Board Description

- 3-ch Interleaved Triangular Current Mode Totem Pole PFC
- Very high efficiency full digital **Totem Pole Three-channel Interleaved PFC**
- The challenge is to achieve **conversion efficiency higher than 99%** with standard Super-Junction MOS In order to meet the 80+TITANIUM standard
- To achieve very high efficiency, the PFC must operate in **Zero Voltage Switching (ZVS) Resonant Mode**
- Control technique: **Hysteresis Current Control**

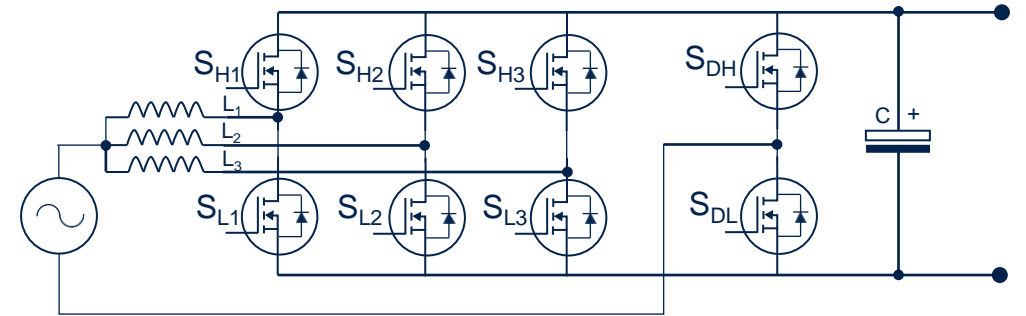

STM32G4

Addressed Market

This topology, thanks the very high efficiency reachable, is suitable for multiple applications:

- 5G Telecom base-stations
- Server
- Industrial power supplies
- Chargers

2kW 3-ch interleaved totem pole ZVS-PFC

Control technique

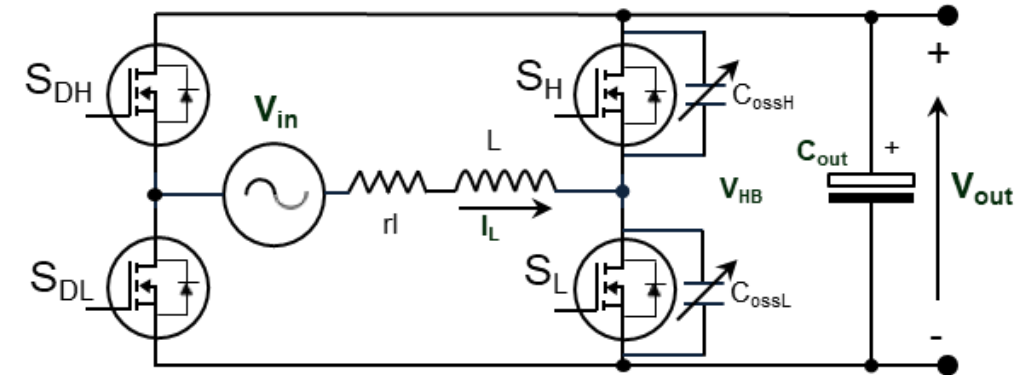
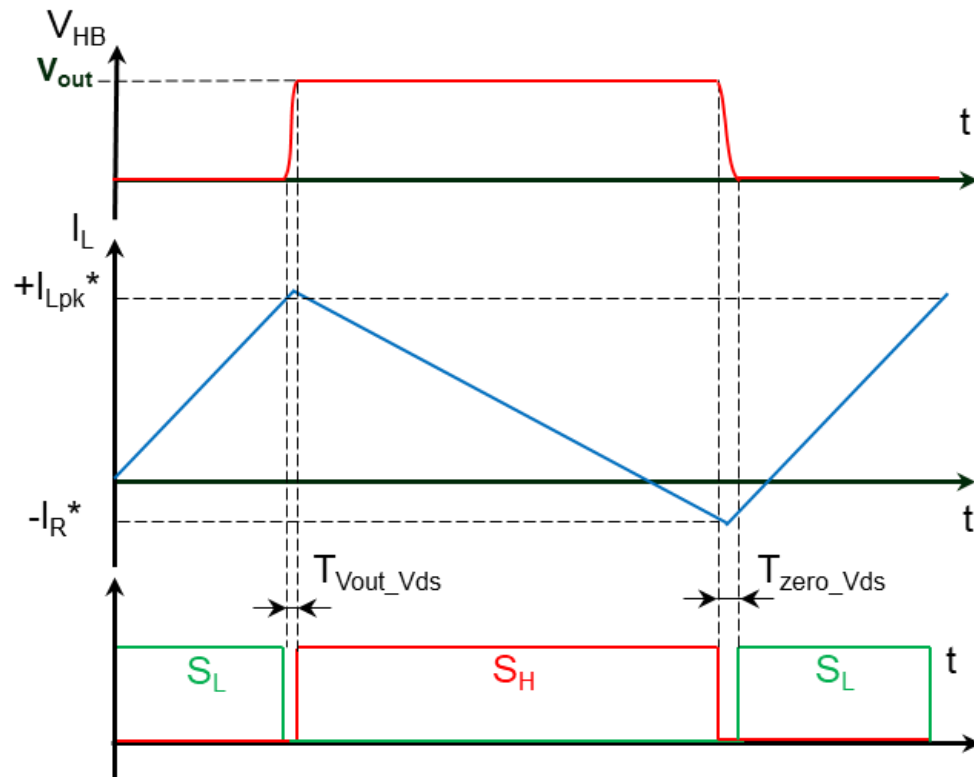

Hysteresis Current Control & ZVS operation

The ZVS operation is guaranteed using the resonance between the inductor L and the output capacitance C_{oss} of the MOSFETs.

Controlling two current thresholds I_{Lpk} , I_R and two dead times T_{vout_vds} and T_{zero_vds} it is possible to guarantee the ZVS operation in any condition

2kW 3-ch Interleaved Totem Pole ZVS-PFC

Board Specs

- $V_{in}=115-230V_{ac}$
- $V_{out}=390V_{dc}$
- $P_{out}=2kW@230V_{ac}$ ($1kW@115V_{ac}$)
- $>99\%$ peak efficiency @ full load, 230Vac
- ZVS Resonant operation (Triangular Current Mode)
- 3ch interleaving with phase shedding
- Hysteresis Current Control
- Variable frequency 20÷80 kHz @full load, 230Vac
- Maximum frequency limitation
- Channel Current balancing
- Over-Current/Voltage/Temperature protection
- Modular approach
- Dimensions [cm] :LxWxH =29.6x9.1x4
- Power density: $1.85 W/cm^3$ ($30.4 W/inc^3$)

Key Products

- STM32G474QET
- STW70N60DM6 600V/36m Ω (High frequency)
- STY145N65M5 650V/12m Ω (Low frequency)
- STGAP2S
- VIPER25

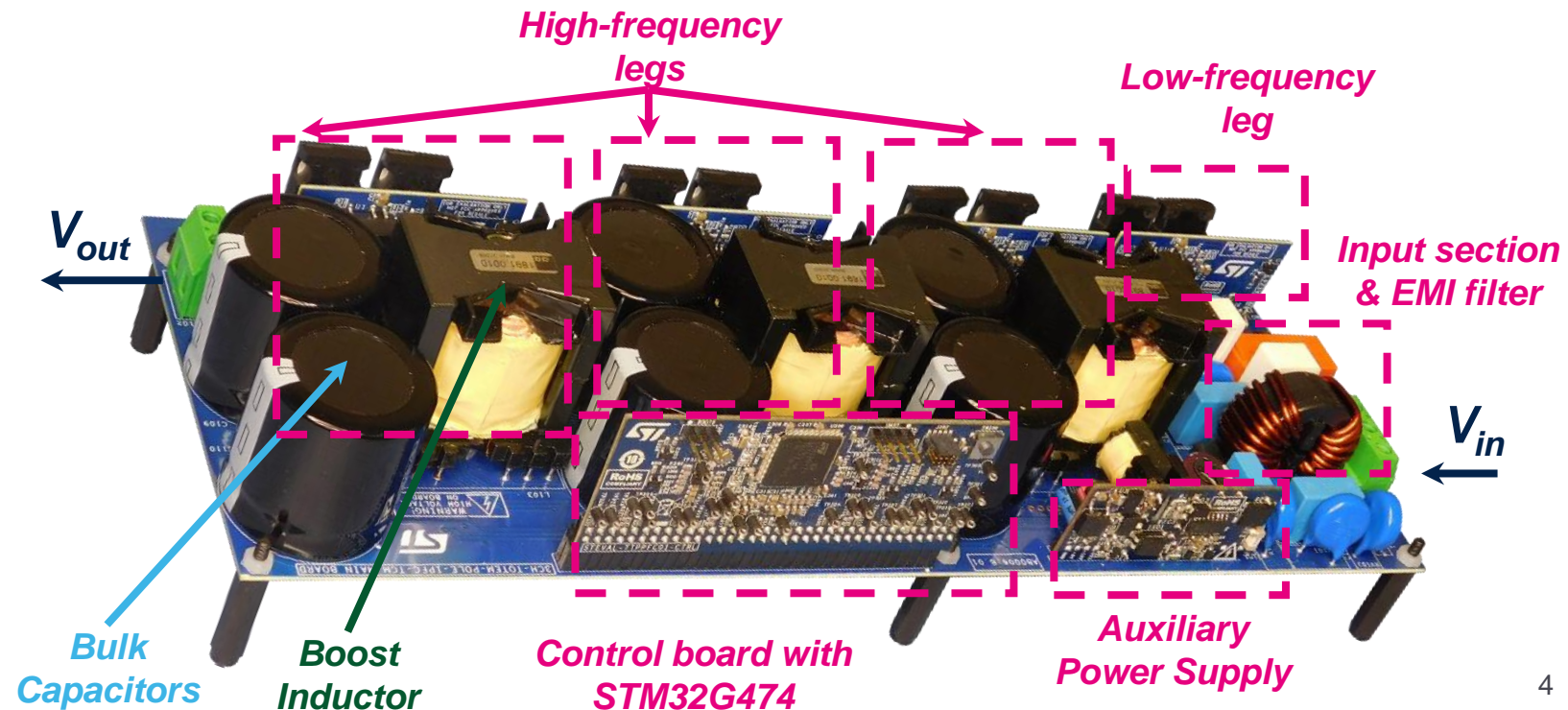

2kW 3-ch Interleaved Totem Pole ZVS-PFC

Waveforms

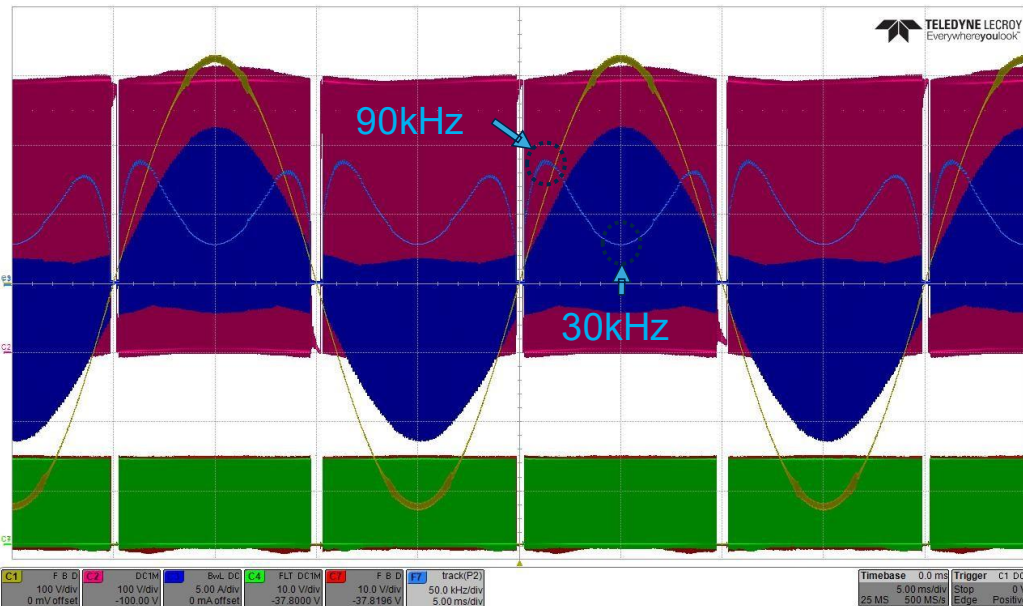

Steady-state PFC waveforms and switching frequency behavior at 230V-670W

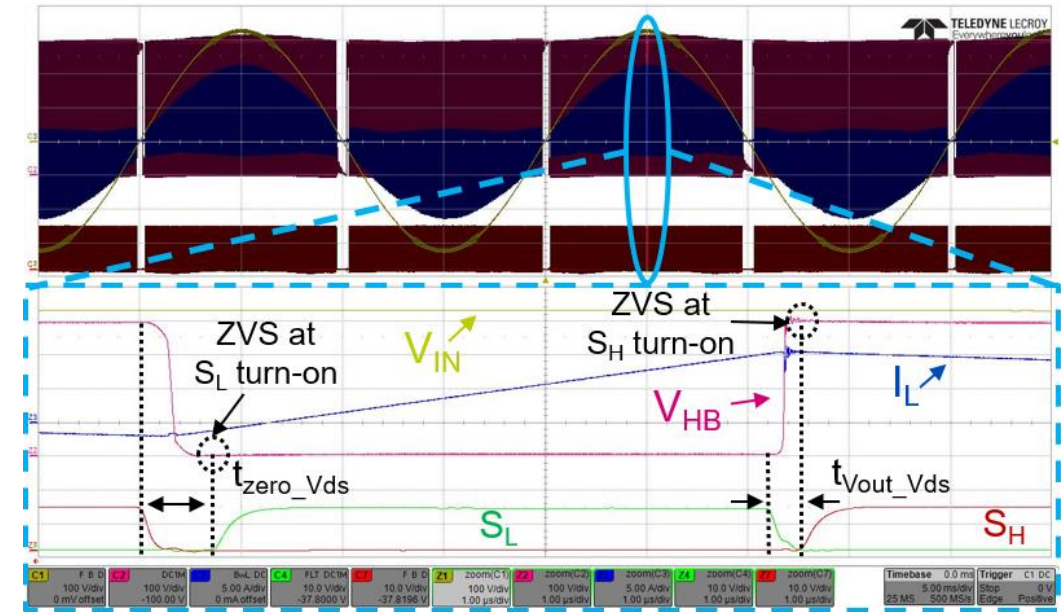

ZVS operation at 230Vac

Performance

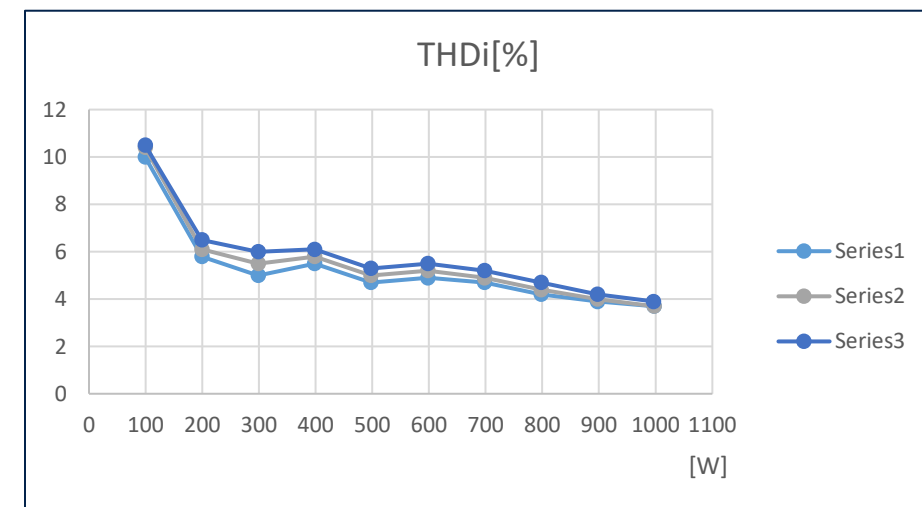
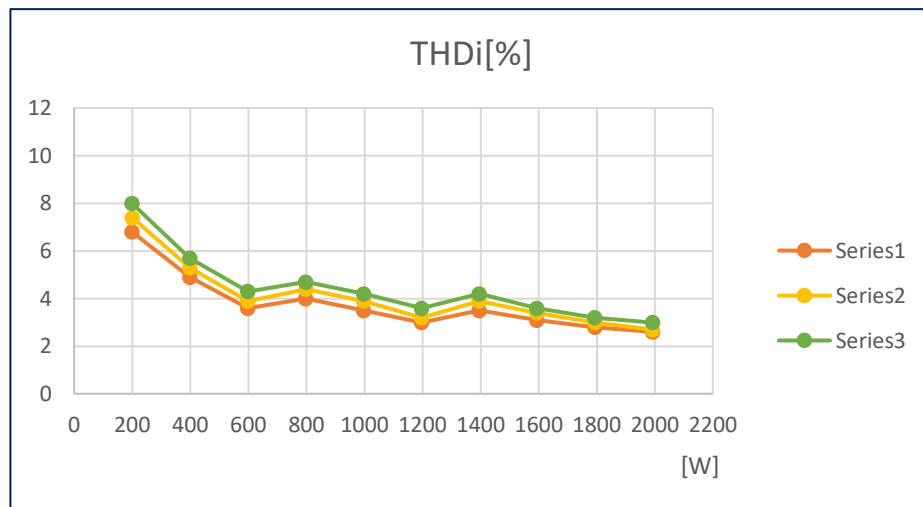
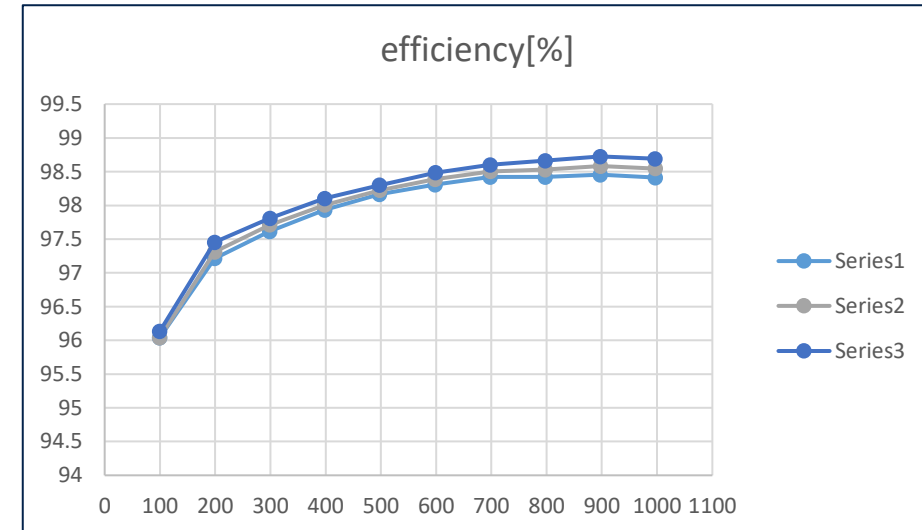
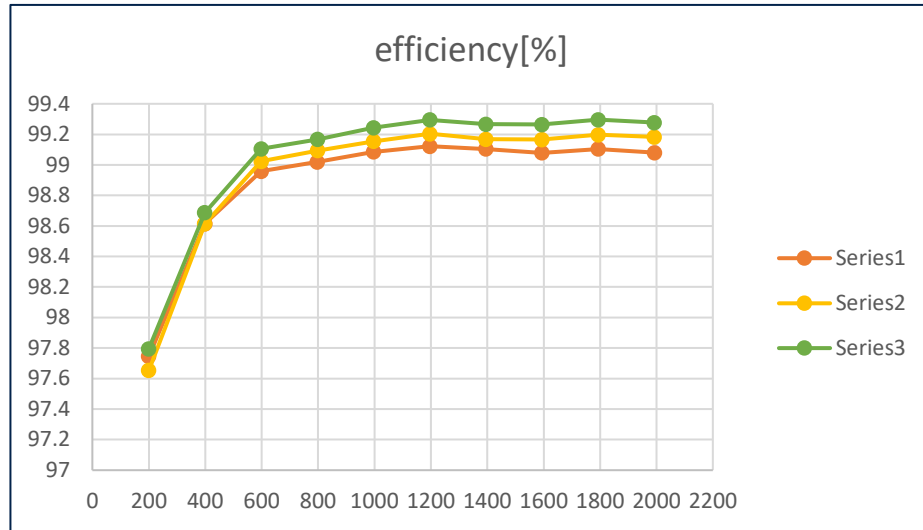

3.6 kW 1-ph Totem Pole PFC

Key Features

- Input AC voltage: **85 VAC up to 264 VAC**
- DC output voltage: **400 VDC**
- Maximum input current: **16 ARMS**

- Compliant to :
 - EN 55015 and IEC 61000-4-11 and IEC 61000-3-3
 - IEC 61000-4-5 surge: 4 kV
 - IEC 61000-4-4 EFT burst : criteria A @ 4 kV min
 - Peak inrush current tuning



Key Products

- **SCTW35N65G2V** (Silicon carbide MOSFET 650 V, 45 mohm)
- **TN3050H-12WY** (SCR Thyristor 30A 1200V)
- **STGAP2S** (Galvanically isolated 4 A single gate driver)
- **Viper26LD** (smart integrated high voltage converter)
- **SMT32F334** 32-bit Microcontroller

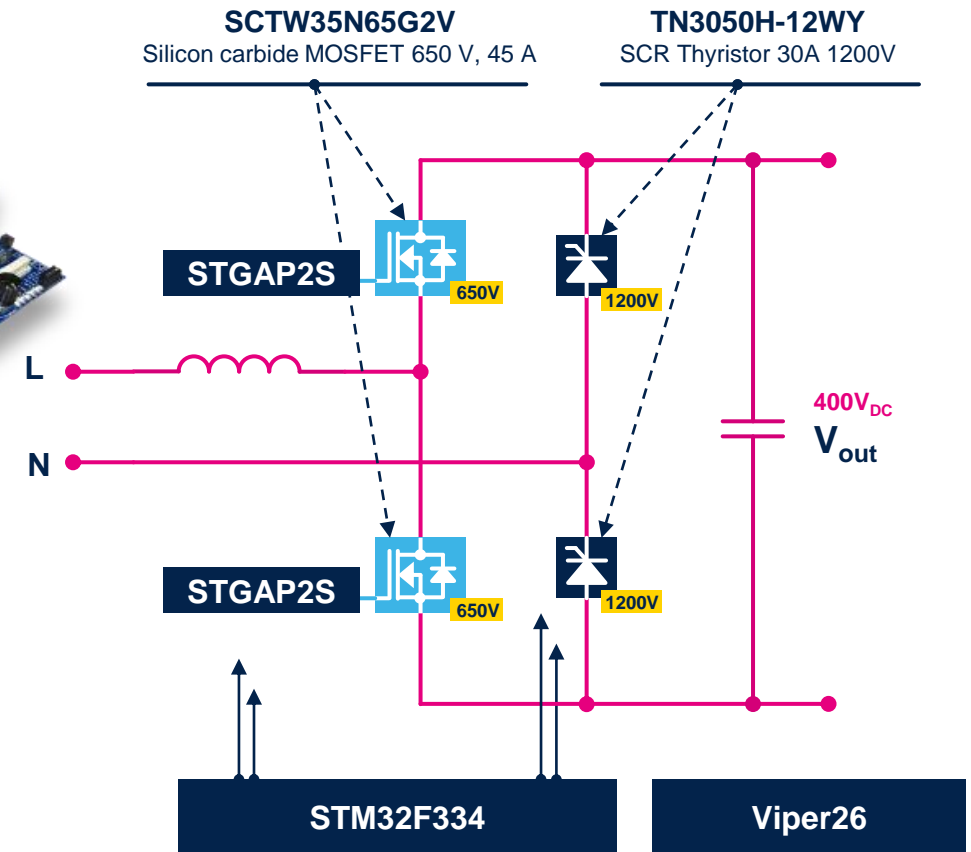

Block diagram

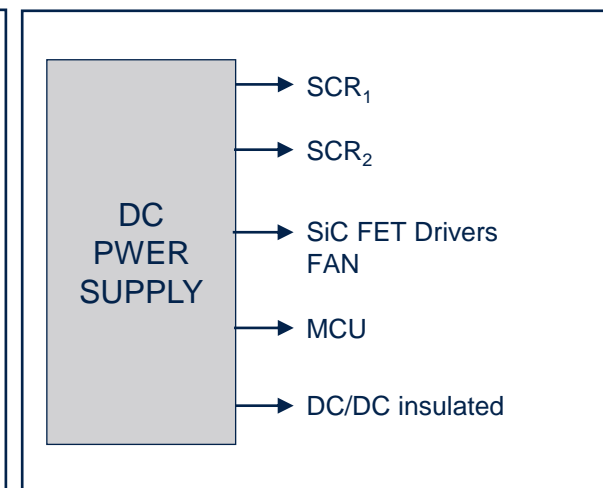
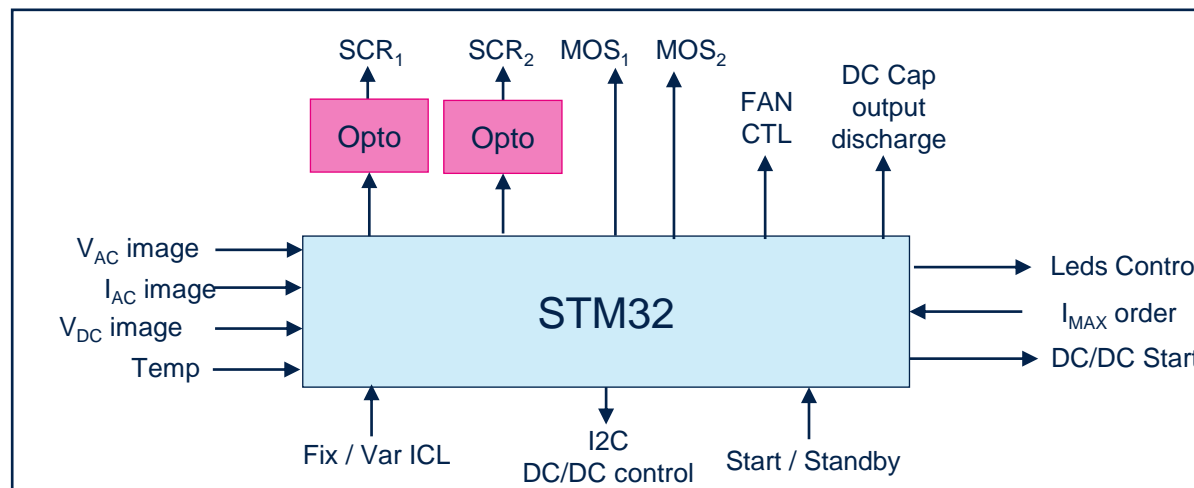
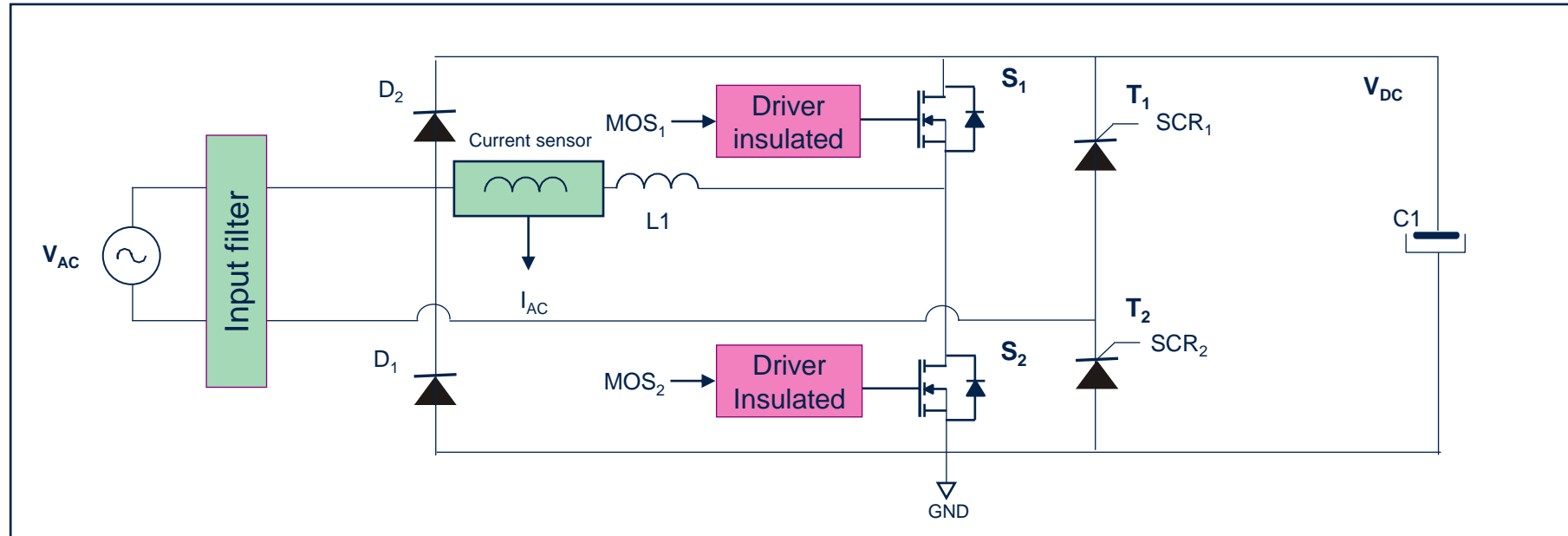



Solid State Bridgeless PFC with Inrush Limiter

Remove electromechanics to improve operating reliability

FORMER WAY

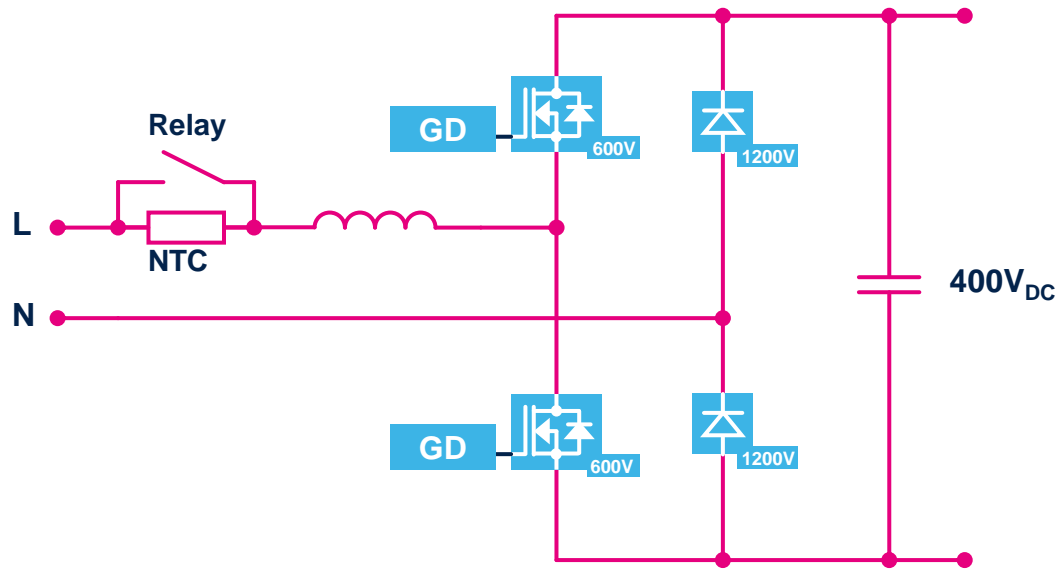

INNOVATIVE WAY

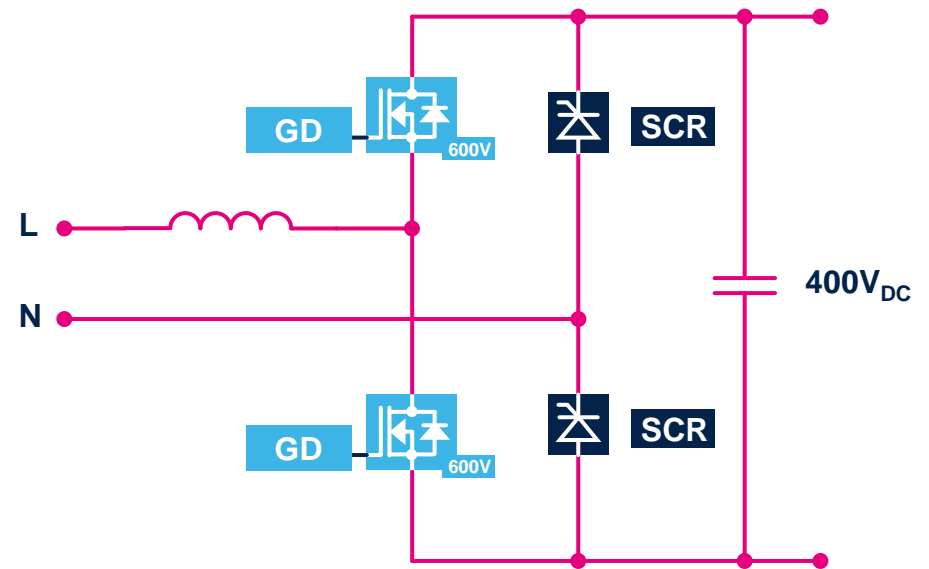

Relay free digital inrush limit control

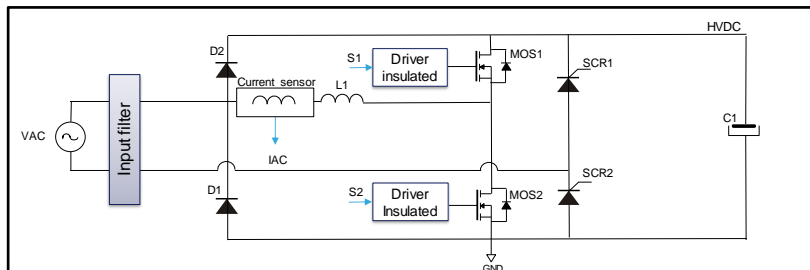
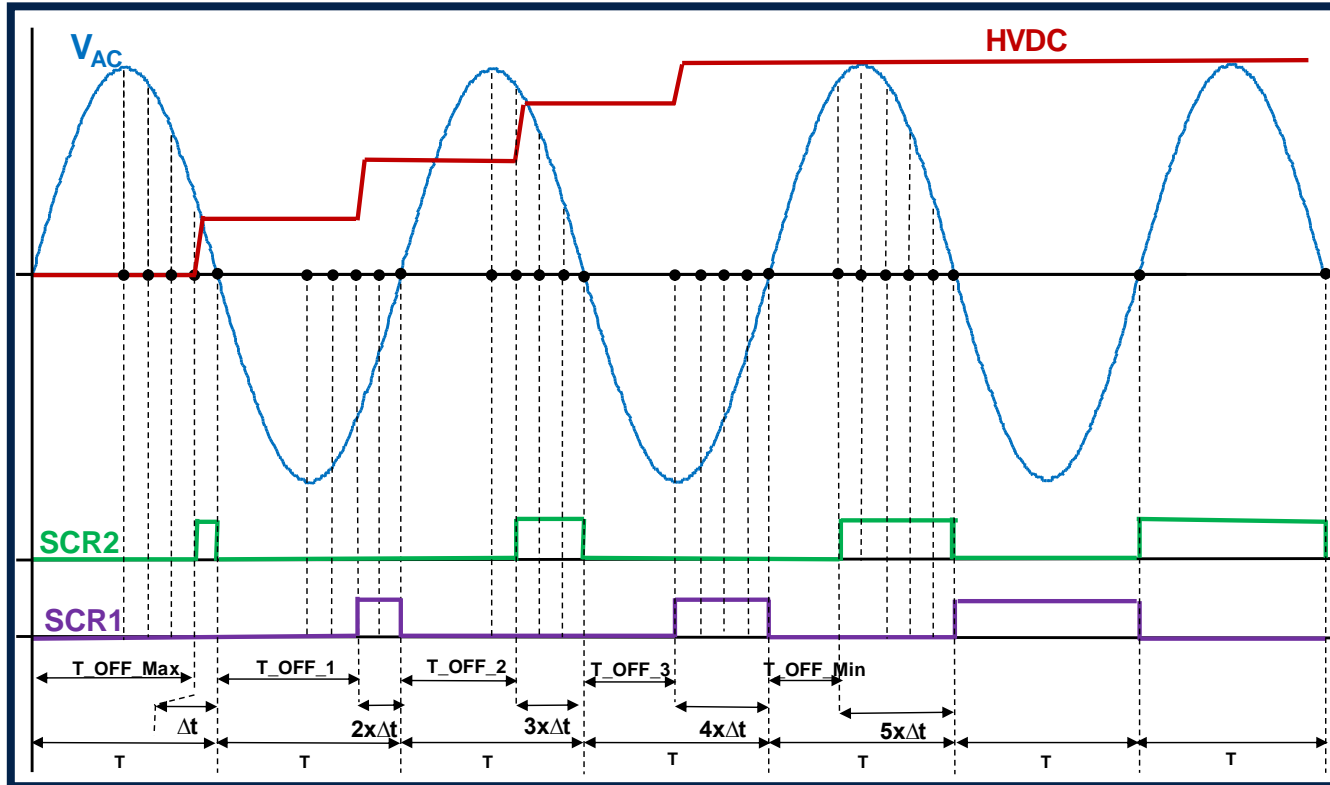

PFC operation in steady state

PFC Efficiency / THD measurement - $T_{amb} = 25^{\circ}\text{C}$

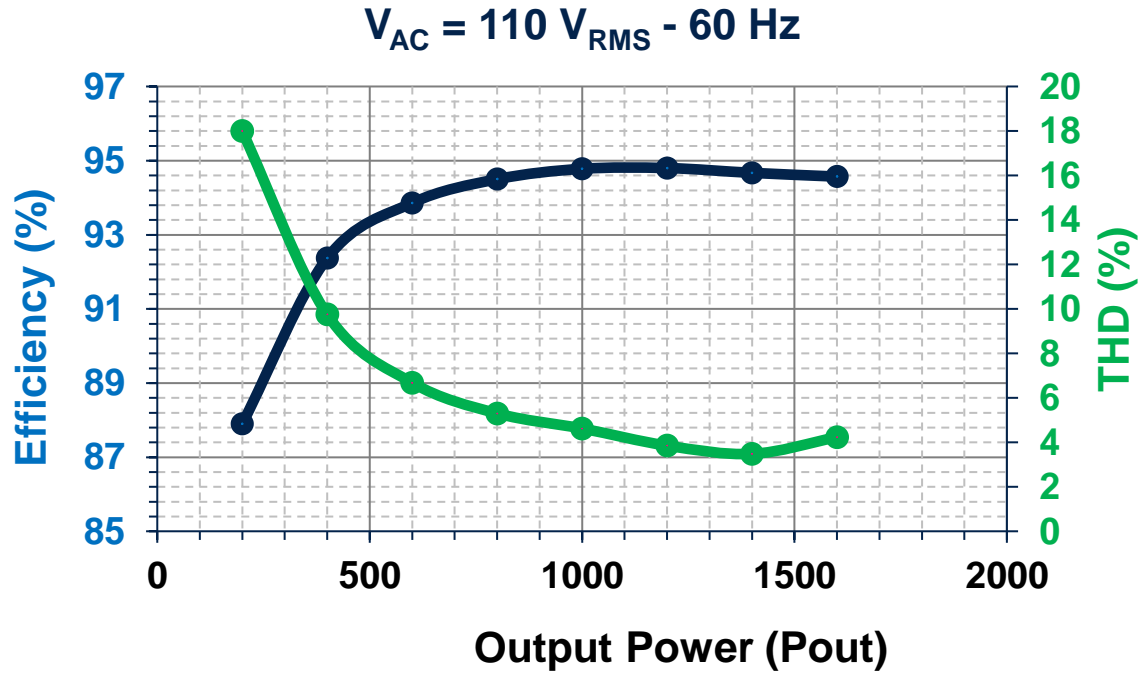
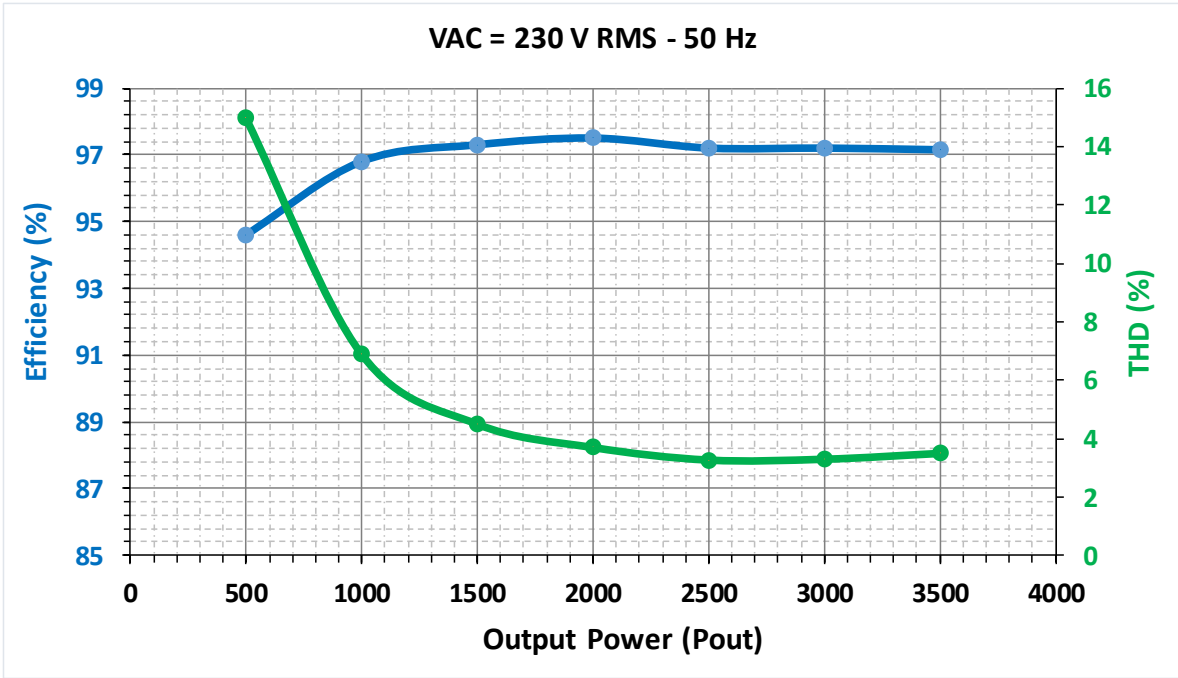

2.5 kW GaN CCM totem pole PFC

Solution Spec.

- ✓ Input Voltage: 120-230 Vac
- ✓ Output Voltage: 400Vdc
- ✓ Output Power: 2.5kW



Server
PSU



Telcom
Power



EV
Charging



Industrial



Key Products

- **SGT65R65A2S** G-HEMT™ GaN - 65 mΩ, 650 V - ultra-fast, zero Qrr e-mode HEMT in 2SPAK package
- **STL57N65M5** MDmesh M5 STPOWER MOSFET 61 mΩ, 650 V in PowerFLAT 8x8 HV package
- **STM32F334R8** 32-bit ARM Cortex-M4 MCU with High Resolution Timer (HRTIM) for digital power
- **STGAP2D** Galvanically isolated 4 A half-bridge dual channel gate driver

STEVAL-DPSTPFC2

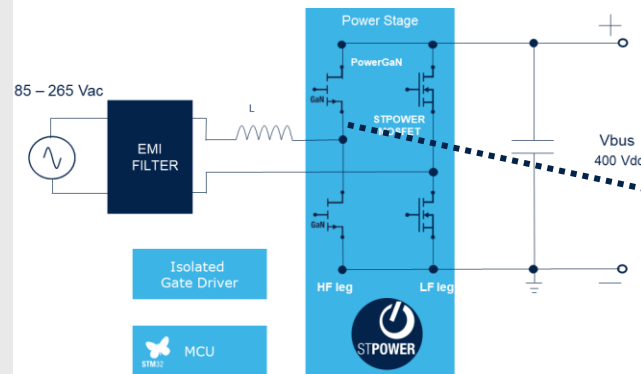

Modular daughter card with **650V G-HEMT PowerGaN**



Key Features

- Based on SGT65R65A2S G-HEMT PowerGaN
- Targets $\geq 99\%$ flat efficiency making easier compliance to 80 Plus Titanium spec and simpler thermal design
- Achieves cycle-by-cycle control loop with PI or 2p2z regulator for precise and fast responsive regulation
- Implements average current-mode control with input voltage feed-forward

Steady state and Turn-On at Pout=1500W

SGT65R65A2S

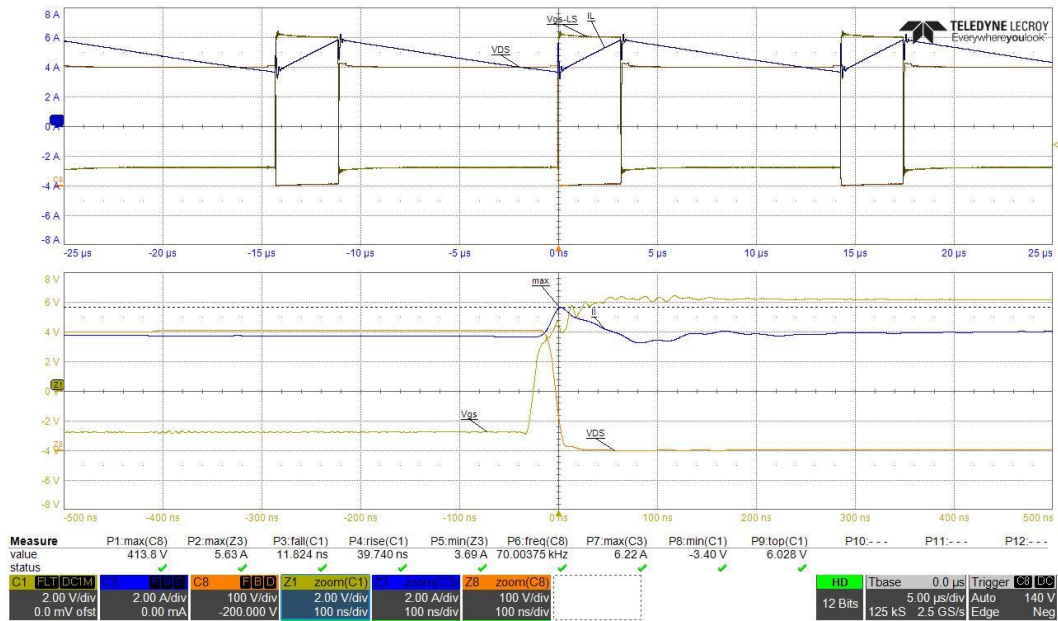

Competition

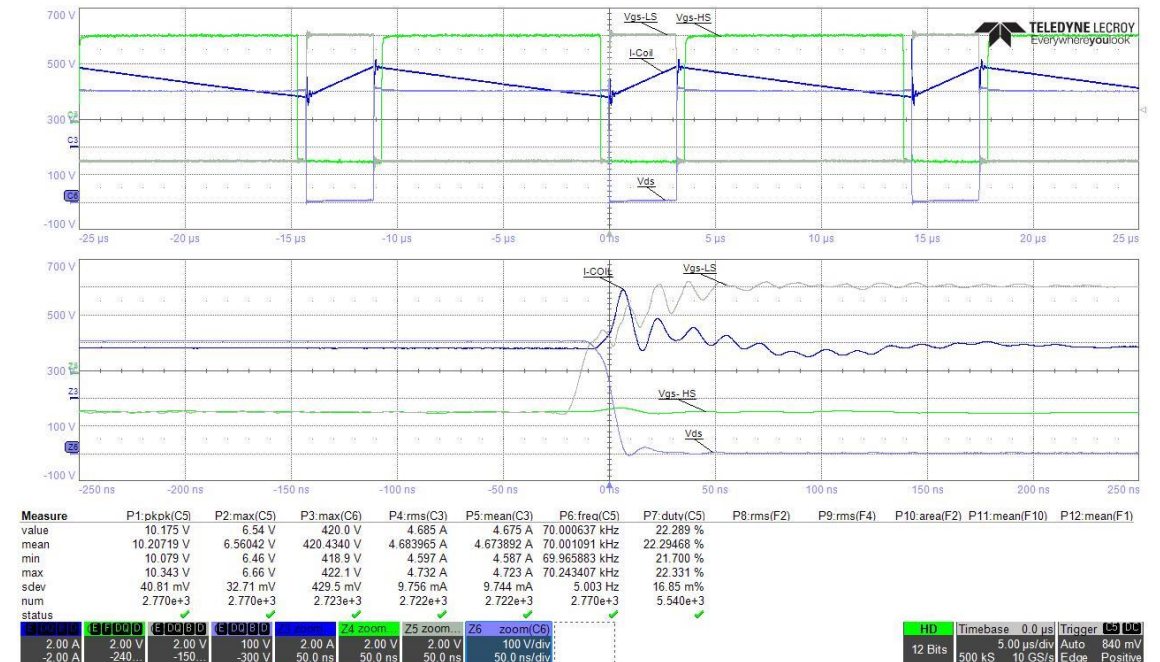

Efficiency

SGT65R65AS2 in a 2.5kW PFC

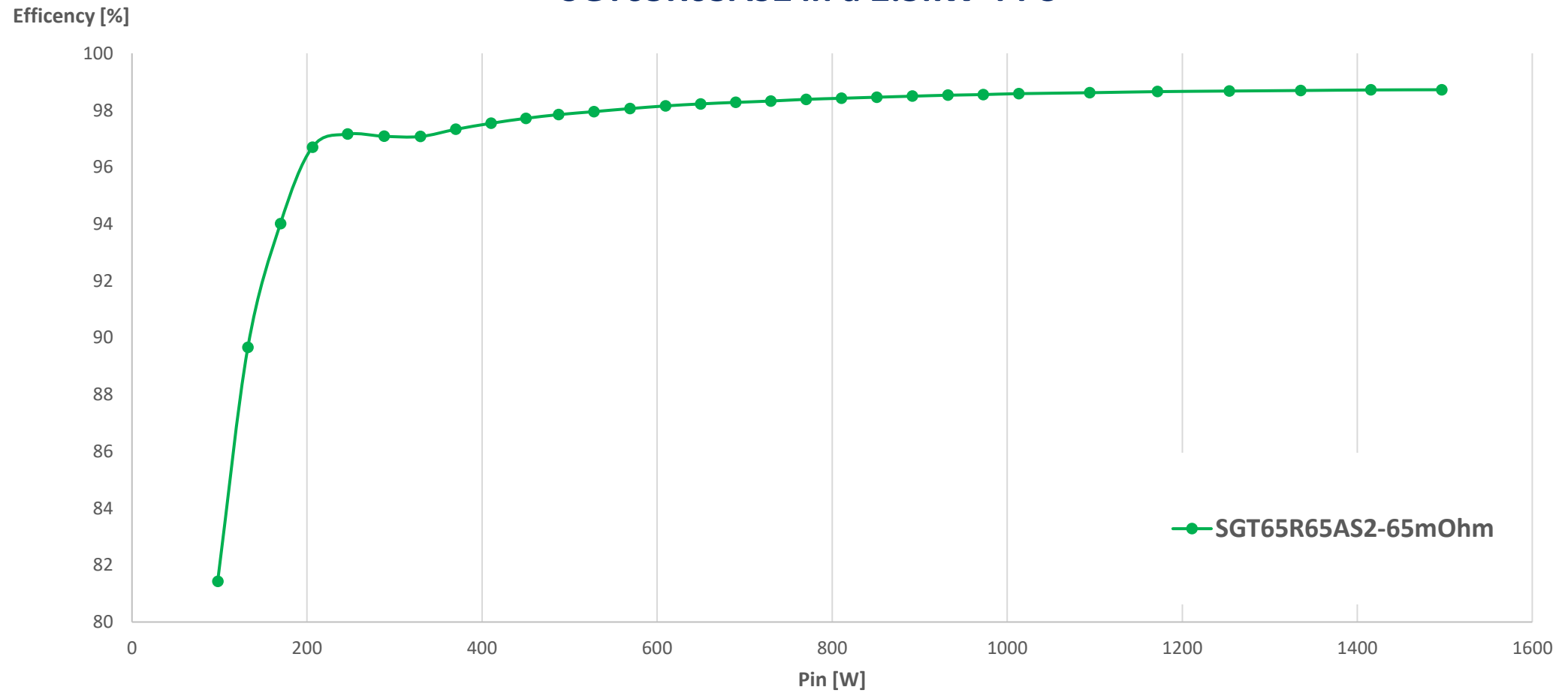

Power semiconductors - Positioning vs. key applications

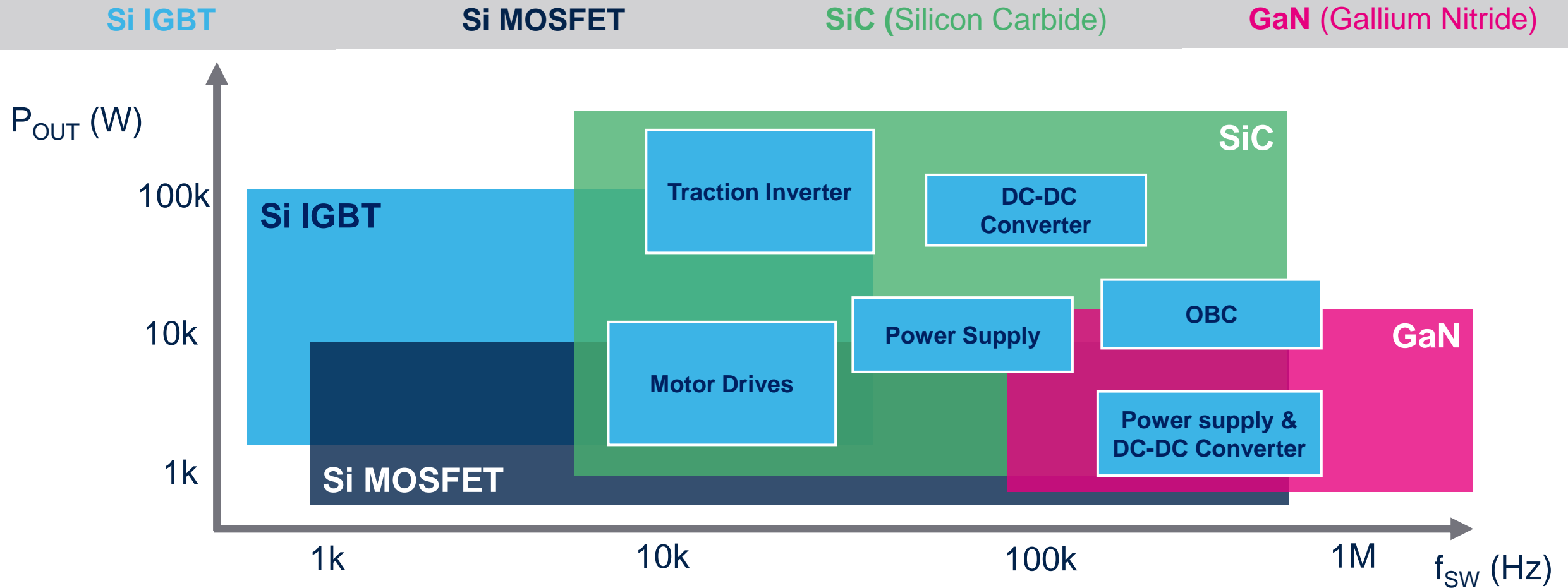

STPOWER SiC MOSFET family overview

The best high voltage and high frequency switch for high density applications



Gen1

1200V-1700V

Very good **Ron vs. Tj** behavior: very suitable for motor drive applications

Gen2

650V, 1200V

Very Good Ron vs. Qg trade-off : highly suitable for a broad range of automotive and industrial **applications**

Gen3

650V, 750V, 900V, 1200V

An ultra-fast series with the **best Ron vs. Qg trade off**: highly suitable for very high frequency applications & AG qualified

GaN: a serious contender of Silicon in power conversion applications

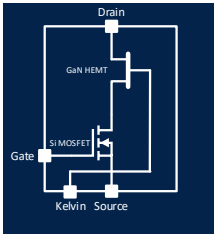

G-FET 650V D-MODE



Very fast, ultra-low Q_{rr} , **robust GaN cascode FET** with **standard silicon gate-drive** for a wide range of power

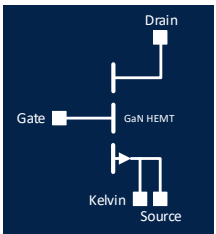

G-HEMT 650V and 100 V E-MODE



Ultra-fast, **zero Q_{rr} e-mode HEMT**, easily parallelable, well suited for **very high frequency and power applications**

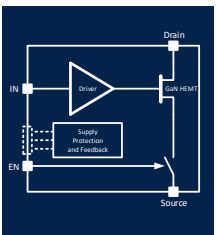

G-DRIVE** 650V D-MODE

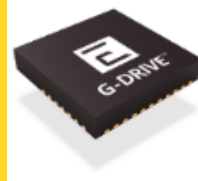

Ultra-fast GaN switch with **embedded gate drive** to simplify board design and minimize parasitic inductance



High Voltage MOSFET Series Super-Junction MDmesh

A complete series for new challenges and opportunities in wide power electronics

Smart cities, smart homes and e-mobility as key elements for 21st century challenges

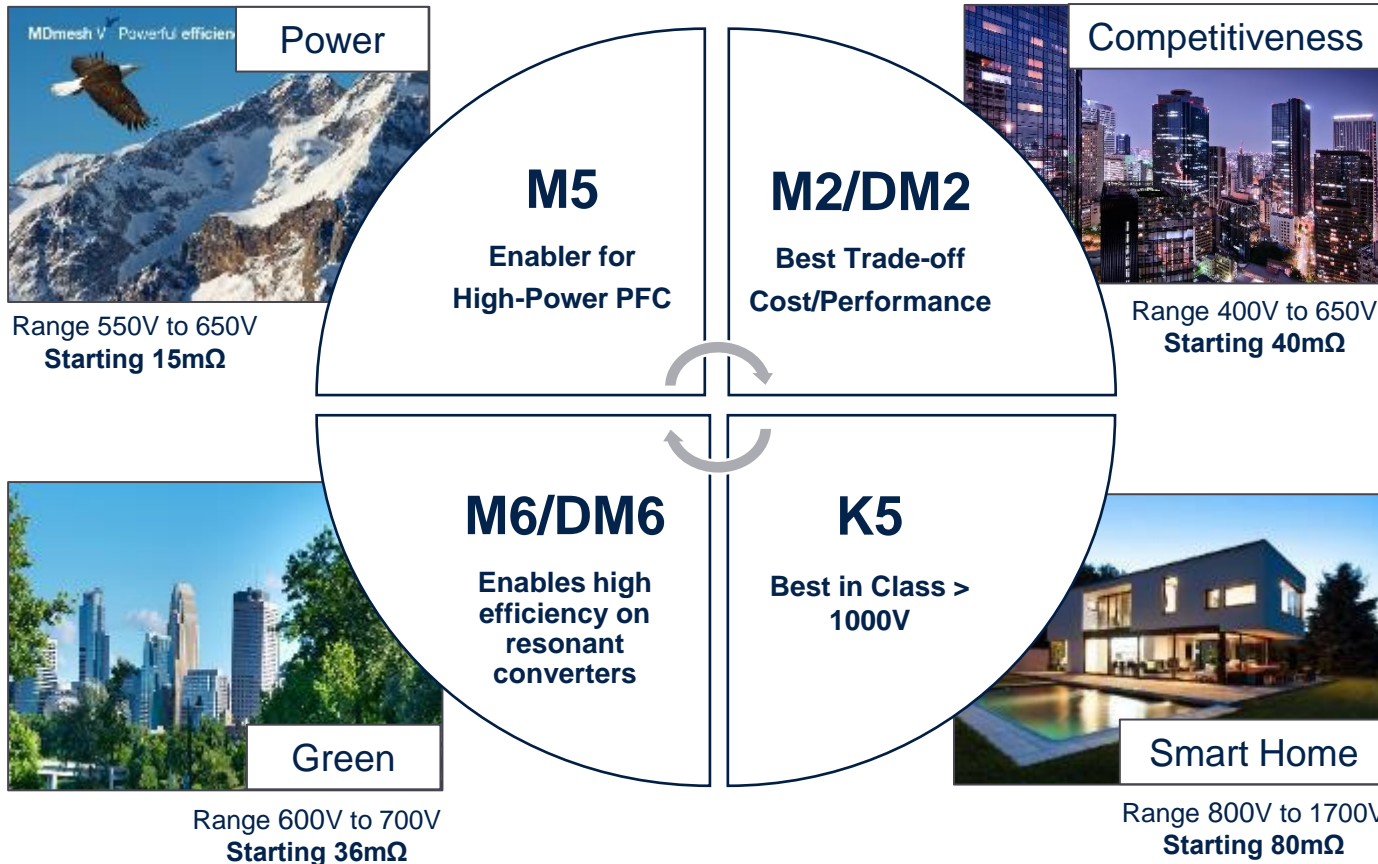

Growth Drivers

- Digitalization and next mobile economy
- Industry 4.0 high efficiency and high reliability targets
- Power density increase
- Better efficiency solutions
- Lower Total Cost of Ownership

Key Applications

- Motor Control and Appliances
- SMPS and LED lighting
- Power Supply for 5G Telecom and Datacenters
- Solar and Energy Storage
- DC/DC converter, OBC and BMS for AUTOMOTIVE



The most innovative SCR thyristor portfolio

Strong & wide SCR range

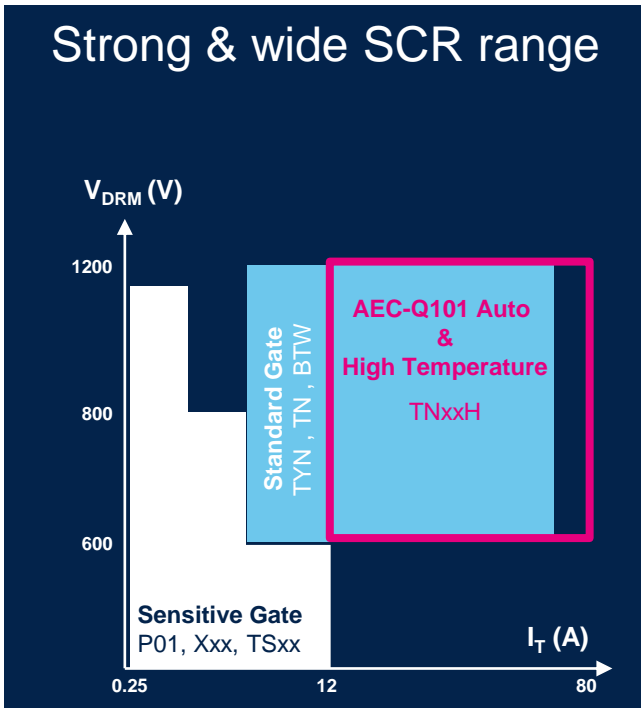

Key Characteristics

V_{DRM} : 600 V to 1200 V

T_J : 125°C and 150°C

I_{TRMS} : 0.25 A to 80 A

I_{GT} : 5 μ A to 50 mA

High immunity @ 150°C

High Temperature Target Applications

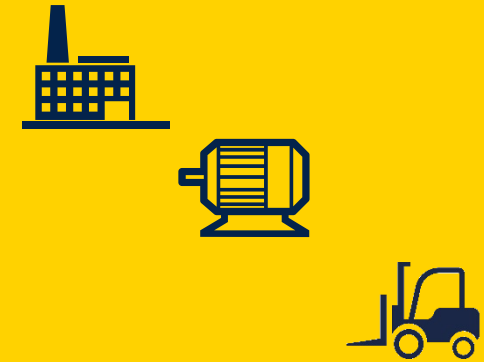

SCR = Silicon Controlled Rectifier

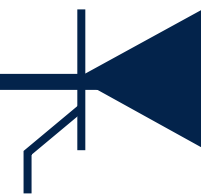

STGAP2 platform

To address a variety of applications

STGAP2S, STGAP2D

1.7 kV isolation single and dual channels

Production



STGAP2HS

6 kV isolation single channel

Production



STGAP2SiCS

6 kV isolation SiC optimized single channel

Production



STGAP2SiCD – STGAP2HD

6 kV isolation dual channels

Development



Motion Control

Factory automation,
Industrial drives, Fan

Power Management

EV charging station, servers,
solar inverter