



**Industrial
Summit 2020**
Shenzhen, China | 2 December
POWERING YOUR INNOVATION



STNRG011/012 数字化PFC+LLC一体电源 解决方案

李哲

功率分立及模拟产品部

意法半导体 亚太区

1 芯片介绍

2 PFC和LLC的技术创新

3 演示板实例介绍

芯片介绍





STNRG011/012 AC-DC电源应用的数字Combo

目标应用： 90W to 300W 开关电源

应用
 LED 照明
 TV 开关电源
 一体机
 工业开关电源
 大功率适配器

主要特点

- TM PFC + 时移 LLC 拓扑
- AC 与 DC 电源管理
- **新型THD优化器**将实现最好的THD
- 工作温度范围：-40°C to 125°C
- 全参数可配置性
- SO20 封装



应用框图

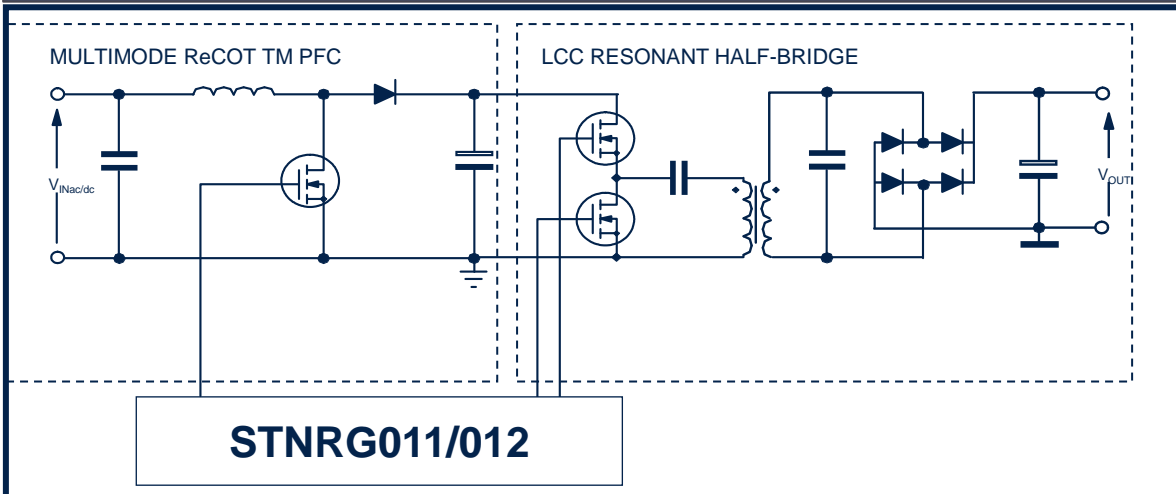



STNRG011/012

数字集成化PFC + LLC控制器

主要特征

- SO20 封装
- 简单实现客户定制化
- 800V高压启动, 自带的输入电压检测以及X电容放电
- 集成PFC和LLC的驱动
- 完整的PFC和LLC保护功能
- UART通讯接口来监控电源
- 特别低的待机功耗(<100 mW)
- 多模式PFC工作: 增强型固定导通时间 (ST专利)
- 时移LLC
- 增强的突发模式

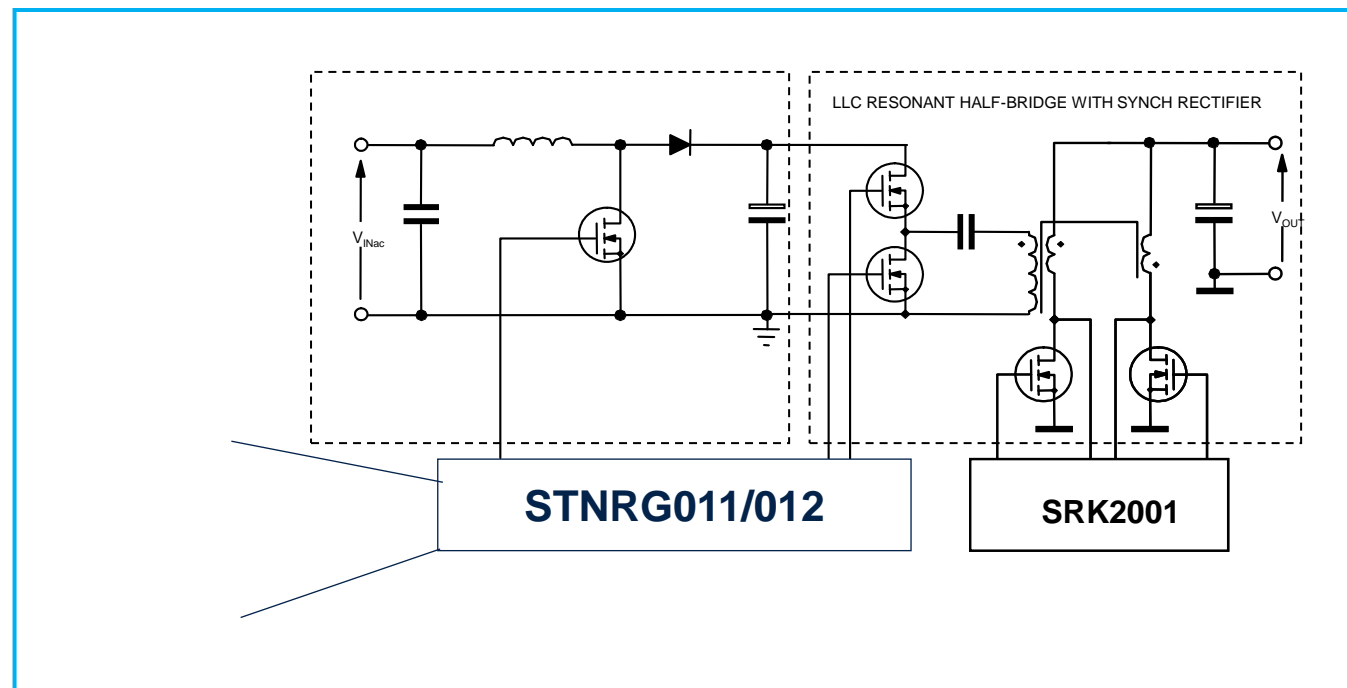

目标应用
90W到300W的开关电源



STNRG011/012 系统原理图和Pin脚配置

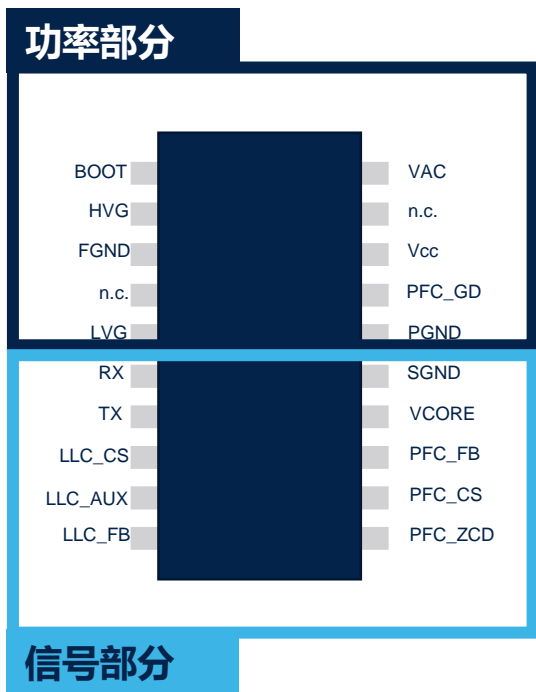

- 上半部分是功率部分
- 下半部分是信号部分

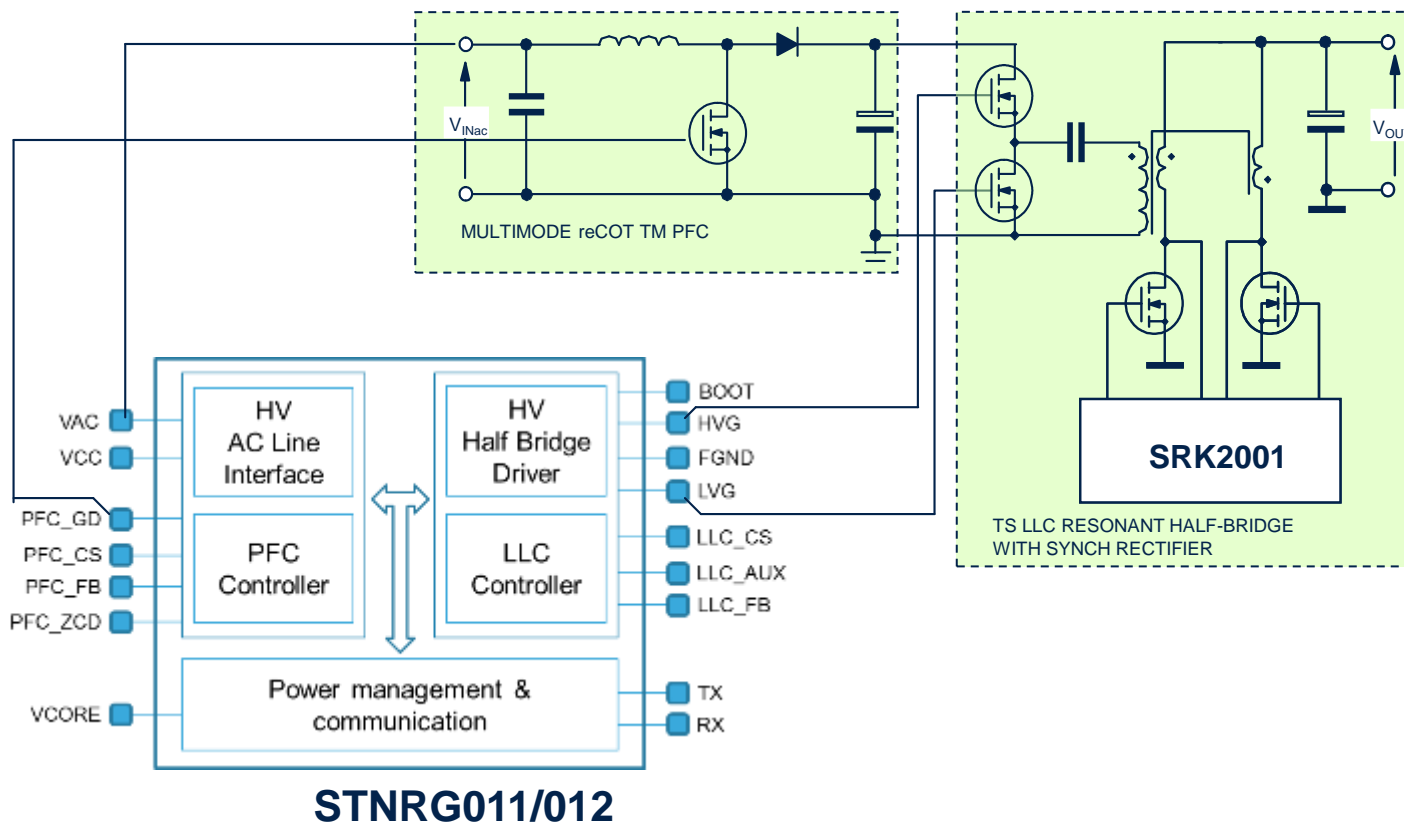



主要性能

- PFC 驱动集成
 - 最高至20V
 - 1A驱动能力
- 集成高压启动和AC电压检测以及X电容放电
- AC断开检测
- 欠压保护
- 浪涌检测

算法 & 工作描述

- 增强型固定导通时间算法 (ST专利)
 - 极好的PF值, 低THD以及快速的动态响应
 - 创新的斜率补偿, 补偿输入的容性负载来实现最高的PF值
- 多模式工作
 - 在中等负载或者满载的时候工作在临界模式
 - 在小负载的时候工作在临界模式, 跳谷底模式
 - 在非常轻负载的时候工作在突发模式



主要性能

- LLC 高压驱动集成
 - 最高至600V
 - 1A 峰值驱动能力
- 匹配通道延时
- dv/dt 承受+/- 50V/ns
- 增强的特征以及保护
 - 安全启动
 - 容性模式保护
 - 过流保护

算法 & 工作描述

- 时移控制(ST专利)
 - 提高动态响应性能
 - 简单的环路补偿
 - 很大的抑制工频纹波
- 突发模式工作
 - LLC驱动突发模式
 - 可调的脉冲个数
 - 在无开关脉冲期间,
大部分电路关闭(ICC=500uA)



STNRG011/012 系统

• 通讯板

- 通过电脑USB接口连接到电源板上
 - UART, I2C和USB协议的转换
 - 测试过程中确保电脑和电源板的电器隔离
 - 给STNRG011供电来实现AET模式和E2PROM的烧入

• 电脑GUI

- NVM参数的读取和烧入(ATE模式)
- E2PROM 的读写
- 读取数据
- IC工作的时候通讯

• PC 工具

- 调谐PFC

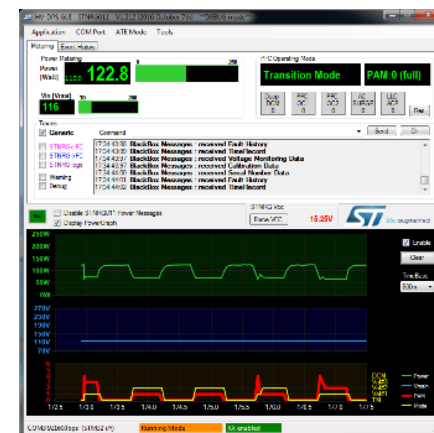



STNRG011/012 相关参数的调整

列举一些可以通过NVM调整的参数 (无需硬件改动)

- 保护行为(锁死 / 自恢复)
- 保护级别& 时序
- 比较器的滤波参数和阈值电压
- PFC 软启动
- PFC 环路参数
- PFC 轻载工作模式
- PFC RECOT 参数(on the fly THD adjustment)
- PFC 最大工作频率
- PFC正常、最小(UVP) 和 最大(OVP) 输出电压
- LLC 死区时间
- LLC 安全启动和软启动参数
- Burst mode 控制 (in/out 阈值, burst 个数定义)

第二部分：PFC和LLC技术创新



PFC部分RECOT 创新

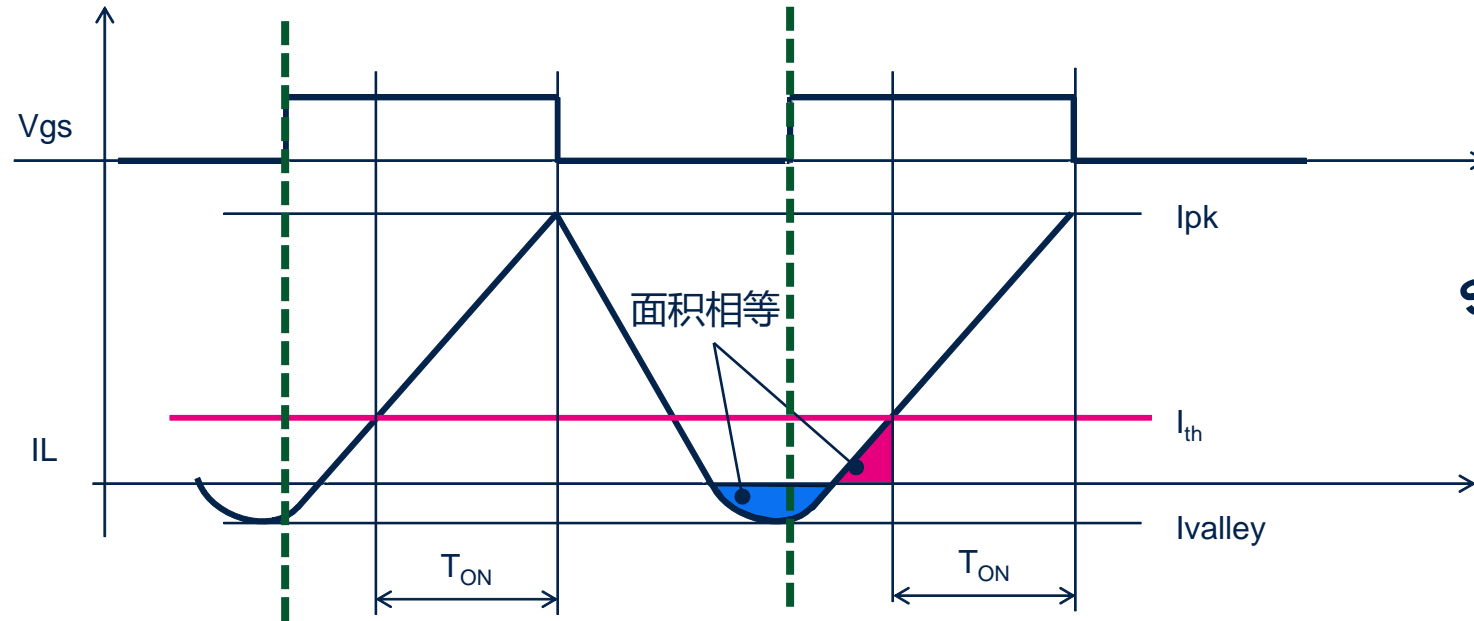

ST 专利

计时器测量ON-time T_{ON} 的起始时间从阈值 I_{th} 开始，因此

$$I_{pk} = \frac{V_{pk}}{L} T_{ON} \sin \theta + I_{th}$$

增加一个适当的补偿 I_{th} 后，每个开关周期的平均电感电流是：

$$\overline{I_L} \approx \frac{1}{2} \frac{V_{pk}}{L} T_{ON} \sin \theta$$

优点：经常准时的非理想性几乎得到补偿，
PF和THD性能与峰值电流模式相同

PFC部分THD优化

- 增强固定导通时间控制努力减小AC输入电流在过零处存在导通死角并造成电流畸变的影响：
 - 如果与根据反馈环路电压计算出了 T_{on} 相比，Re-COT的补偿效果更好。因为在开始计算 T_{on} 周期的时候，定义最小电流电平，这就允许PFC有能力处理更多的能量。这不仅包含给MOS充电的能量，也使在线电压很低的情况下，能量传输更加高效。此外，Re-COT可在大的输入滤波电容存在的情况下补偿回流的能量（电流）

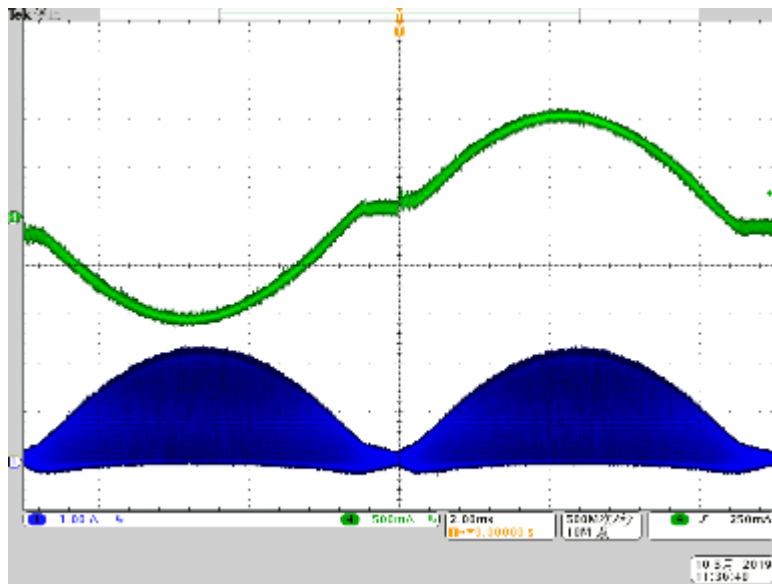

补偿前

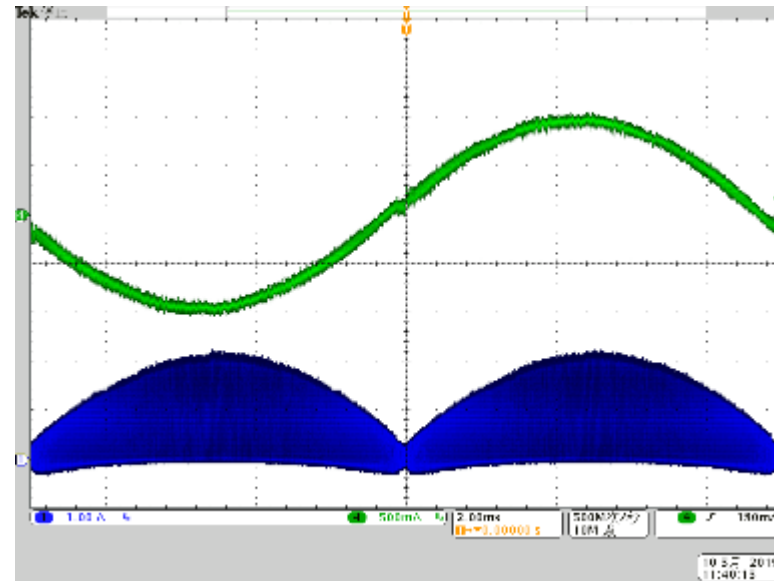

补偿后

PFC轻载工作模式优化

PFC的工作状态可以根据负载的不同工作在不同的模式

满载 (临界模式)

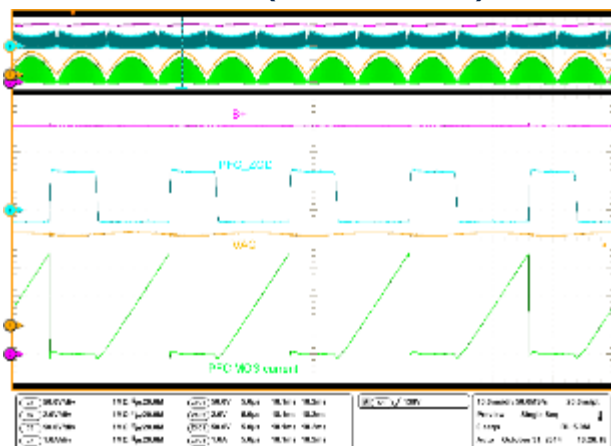

中等负载 (跳谷底模式)

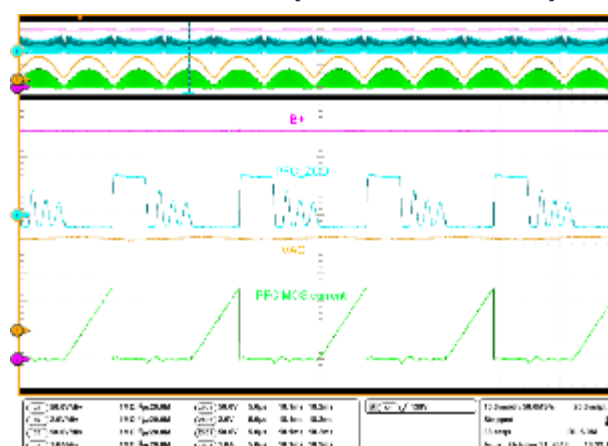

轻载 (突发模式)

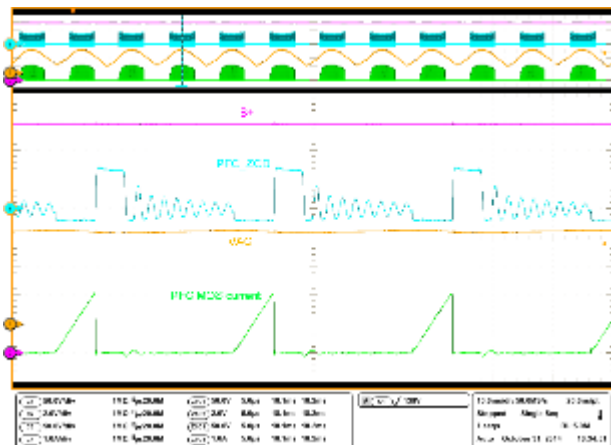
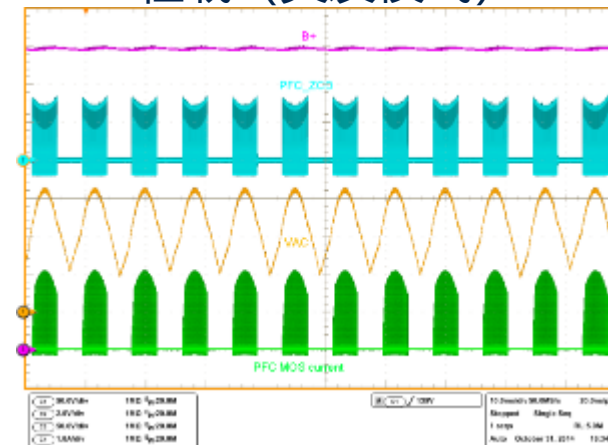

详细

LLC时移控制创新

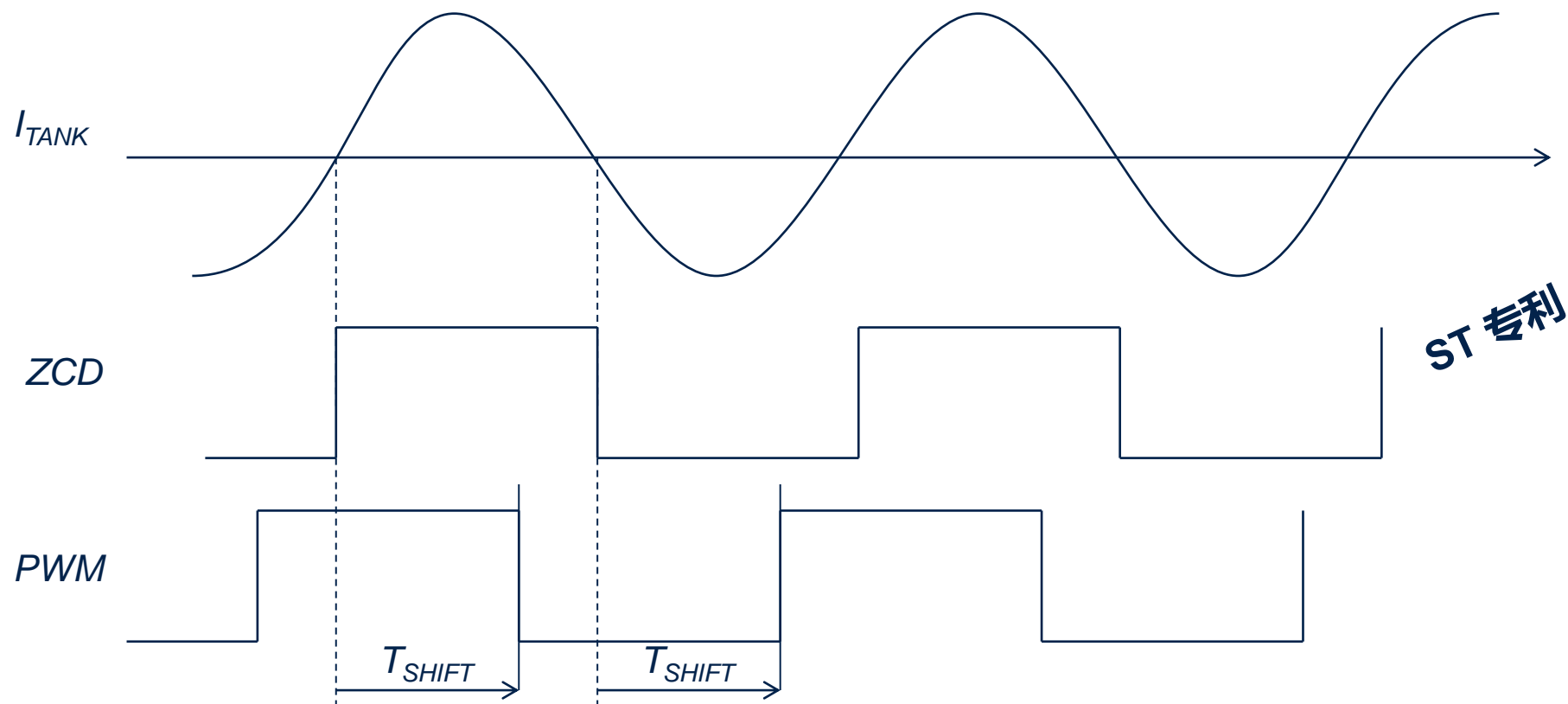

- 时移 T_{SH} 定义为从槽电流过零点到下一个半桥切换的时间

时移控制消除了LLC在启动过程中的硬开关

直接频率控制

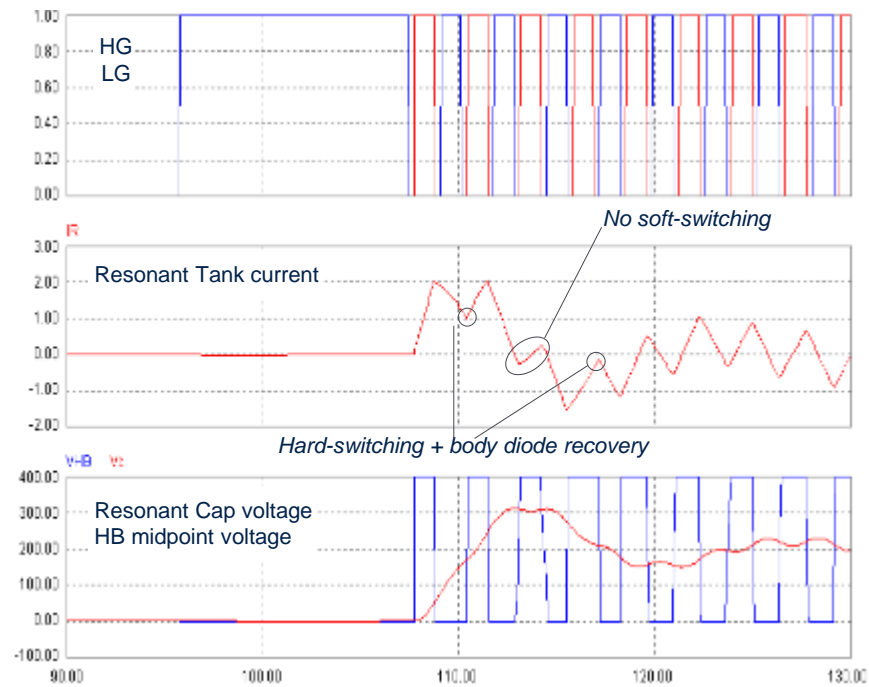

时移控制

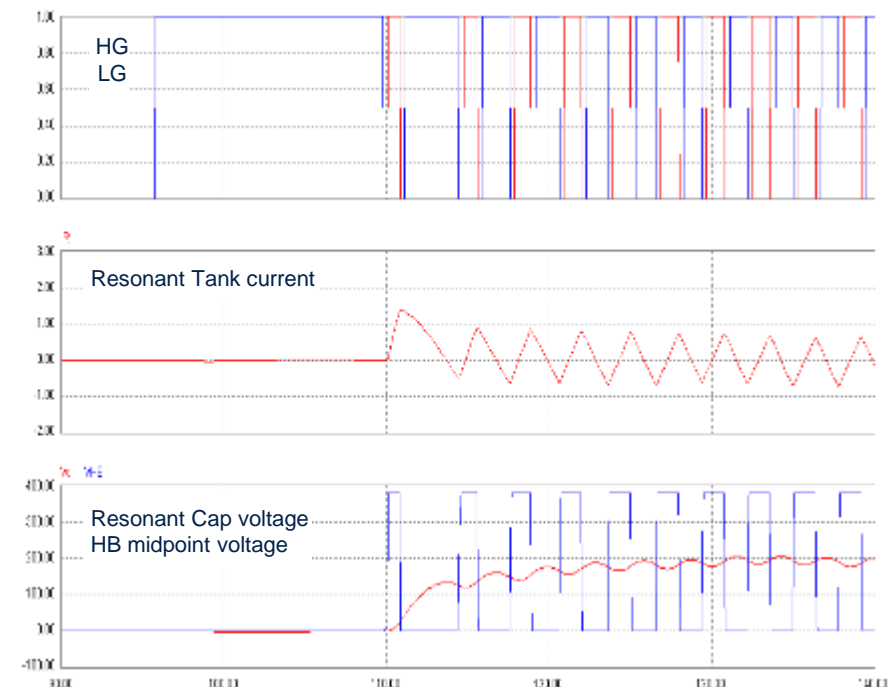

时移控制的优势

时移控制降低100Hz的输出纹波降低

- 测试条件: 24V/170W LLC @ $V_{indc} = 395V$, PFC 关断

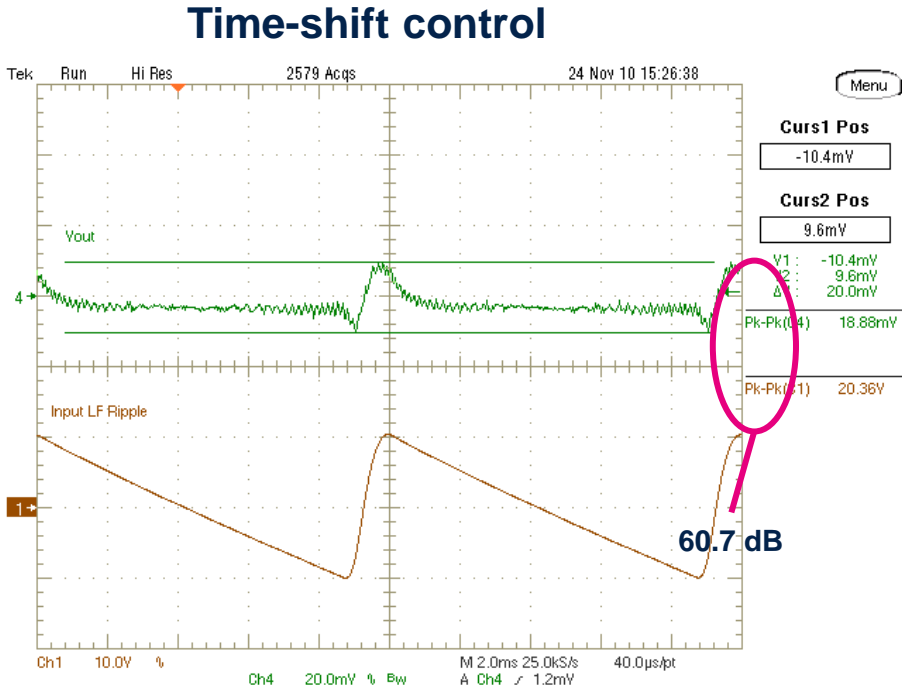
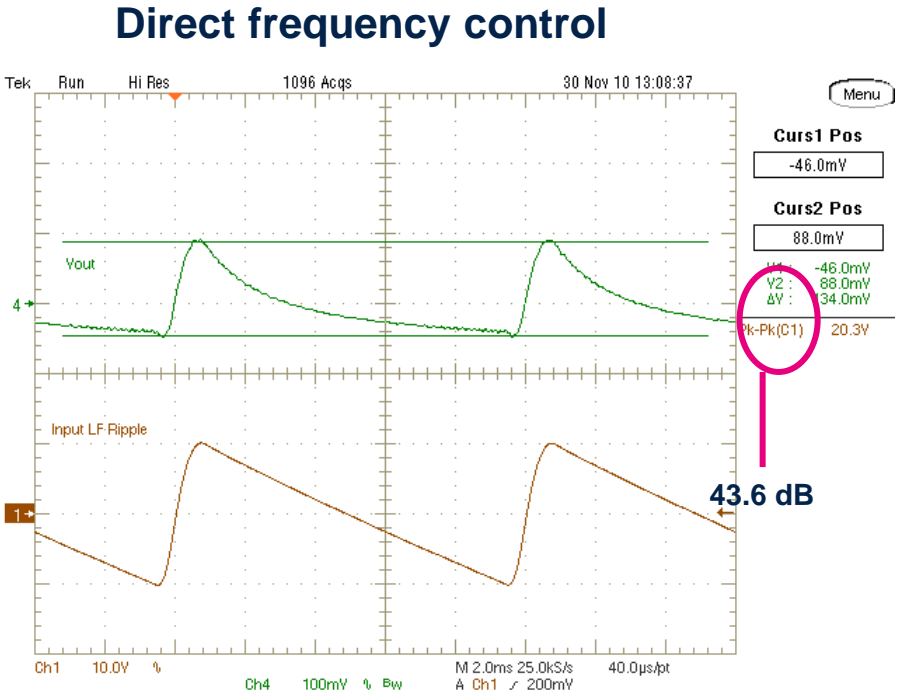

- 100 Hz输出电压纹波从134mV降低到19mV

第三部分：演示板介绍



演示板 - 150W适配器

STNRG011

量产 & 演示板可供

基于STNRG011+SRK2001的150W-12V 适配器演示版



GUI接口更简单实现相关配置

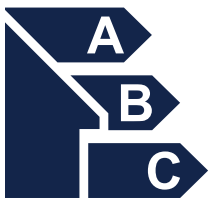

效率最大化



可编程更改和数据监控



全集成



150W适配器性能

115Vac	Vout [V]	Iout [A]	Pout [W]	Pin [W]	η [%]
100mW	12.039	0.009	0.11	0.19	57.03
250mW	12.042	0.02097	0.25	0.38	66.45
500mW	12.037	0.04189	0.50	0.69	73.08
10%	12.042	1.254	15.10	18.93	79.77
20%	12.04	2.498	30.08	34.68	86.72
25%	12.039	3.126	37.63	42.64	88.26
50%	12.035	6.255	75.28	82.70	91.03
75%	12.027	9.369	112.68	122.71	91.83
100%	12.022	12.498	150.25	164.14	91.54
Average (100, 75, 50, 25 %) = 90.66					

230Vac	Vout [V]	Iout [A]	Pout [W]	Pin [W]	η [%]
100mW	12.04	0.009	0.11	0.20	54.18
250mW	12.042	0.02097	0.25	0.38	66.45
500mW	12.037	0.04167	0.50	0.69	72.69
10%	12.042	1.254	15.10	18.63	81.06
20%	12.04	2.498	30.08	34.15	88.07
25%	12.038	3.126	37.63	42.06	89.47
50%	12.035	6.255	75.28	81.72	92.12
75%	12.031	9.369	112.72	121.12	93.06
100%	12.028	12.498	150.33	161.43	93.12
Average (100, 75, 50, 25 %) = 91.94					

Load	115Vac		230Vac	
	THD	PF	THD	PF
50%	6.90%	0.9835	10.80%	0.9323
60%	4.50%	0.989	8.20%	0.9517
70%	4.20%	0.9918	8.00%	0.9628
80%	3.90%	0.9936	7.70%	0.9701
90%	3.70%	0.9944	3.40%	0.9872
100%	3.30%	0.9948	3.10%	0.9823

No load	Pin
115 Vac	51 mW
230 Vac	63 mW

非常低的待机功耗



150W适配器性能

load	Vout (PK-PK)
0-12.5A动态 10ms/10ms	650mV
0-12.5A动态 100ms/100ms	700mV

load	Vout (PK-PK)
12.5A	53mV
1A	25mV
0.025A	76mV
0A	45mV

Figure 51. Iout = 0.0 A - 12.5 A, 10 ms / 10 ms

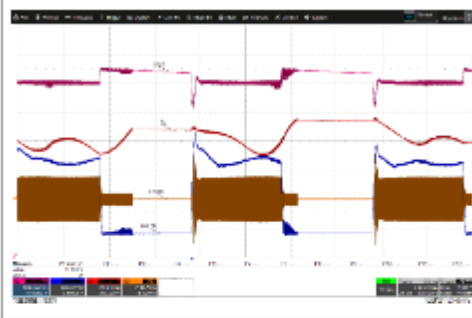

Figure 52. Iout = 0.0 A - 12.5 A, 10 ms / 10 ms (zoom)

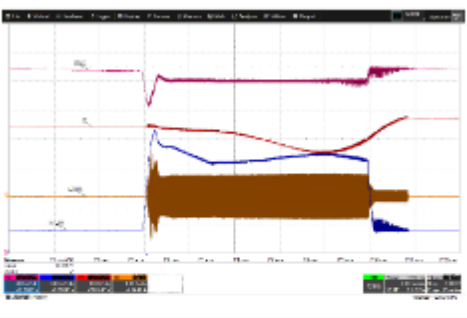

Figure 53. Iout = 0.0 A - 12.5 A, 100 ms / 100 ms

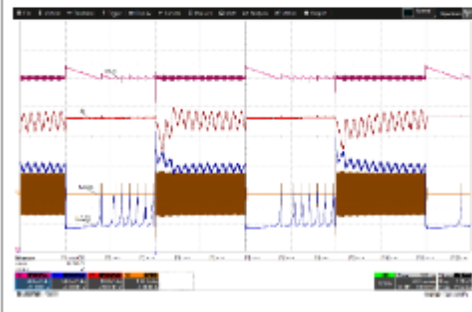

Figure 54. Iout = 0.0 A - 12.5 A, 400 ms / 400 ms

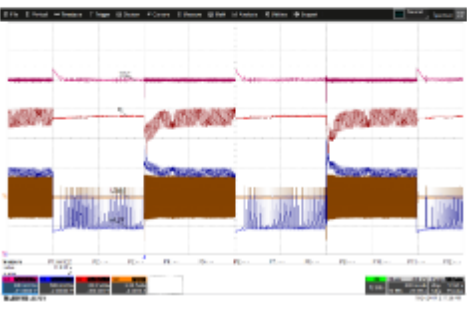

Figure 62. Vout at Iout = 12.5 A

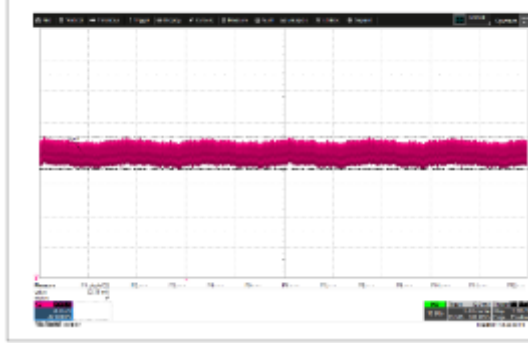

Figure 63. Vout at Iout = 1.0 A

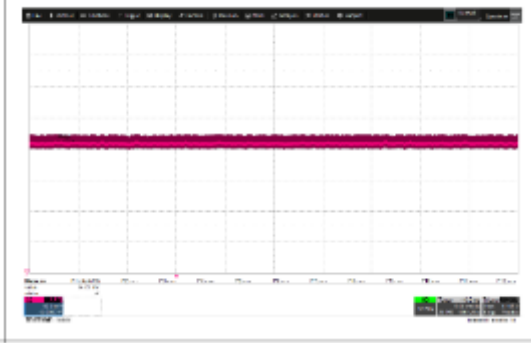

Figure 66. Vout at Iout = 0.025 A



Figure 67. Vout at Iout = 0.0 A, no-load





演示板 - 150W LED照明

基于STNRG011的150W LED照明



maximum efficiency

programmability and data monitoring

fully integrated

性能参数

No	主要参数	说明
1	输入范围(Input): 90~265vac	
2	- Vout=5~150v/Iout=0.4~1A - Vout=50~150v/Iout=10mA~1A	
3	EN61000-3-2 Class-C compliance for Pin>=25w @230vac	THD<20% for Pin>=25w @230vac
4	全程无频闪 (1% ~100)	
5	峰值效率 = 93% / 满载 / 230vac	

150W LED照明应用测试报告

Vin (Vac)	Iout (A)	DIM(V)	Vout (Vdc)	PF	THD (%)	Pin (W)	Pout (W)	Eff (%)	class-C
90	0.122	1.2	150	0.987	8.65	25.5	18.30	0.72	pass
	0.172	1.60	150	0.991	8.38	33.38	25.80	0.77	pass
	0.337	3.30	150	0.99	5.09	61.05	50.55	0.83	Pass
	0.507	5.00	150	0.99	3.97	85.8	76.05	0.89	pass
	1.000	10.00	150	0.99	3.08	168.7	150.00	0.89	Pass
115	0.130	1.20	150	0.97	13.34	24.5	19.50	0.80	pass
	0.170	1.60	150	0.97	10.7	33.3	25.50	0.77	pass
	0.340	3.30	150	0.991	8.98	59.6	51.00	0.86	Pass
	0.510	5.00	150	0.996	6.02	87.1	76.50	0.88	pass
	1.000	10.00	150	0.999	2.9	165.8	150.00	0.90	Pass
230	0.130	1.30	150	0.76	14.75	25.8	19.50	0.76	pass
	0.163	1.60	150	0.88	13.6	31.37	24.45	0.78	pass
	0.327	3.30	150	0.925	9.71	57	49.05	0.86	Pass
	0.496	5.00	150	0.96	4.83	83.4	74.40	0.89	pass
	1.000	10.00	150	0.99	2.99	162.2	150.00	0.92	Pass
265	0.130	1.30	150	0.679	18.19	25.9	19.50	0.75	pass
	0.158	1.60	150	0.72	17.6	30.17	23.70	0.79	pass
	0.329	3.30	150	0.89	13.35	58.1	49.35	0.85	pass
	0.500	5.00	150	0.932	12.8	83.7	75.00	0.90	Pass
	1.000	10.00	150	0.98	4.15	160.5	150.00	0.93	Pass

150W LED test report

THD vs input power

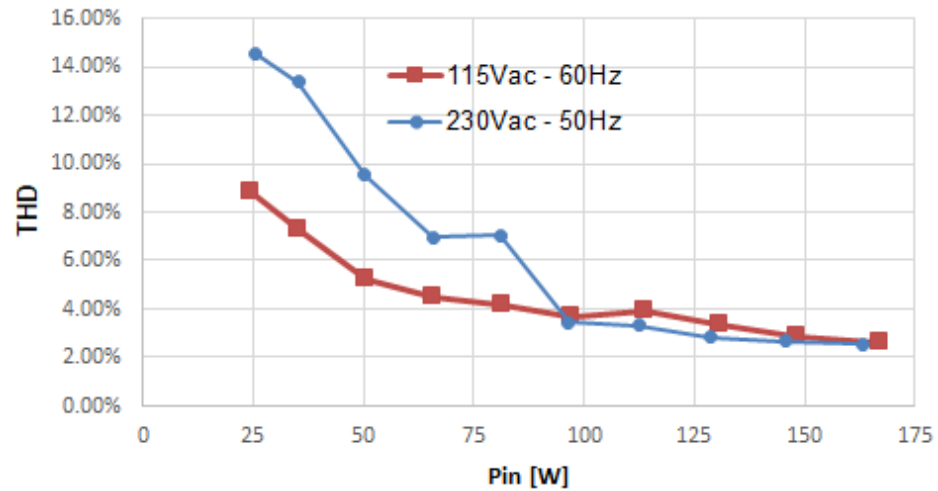

Efficiency vs Output Load

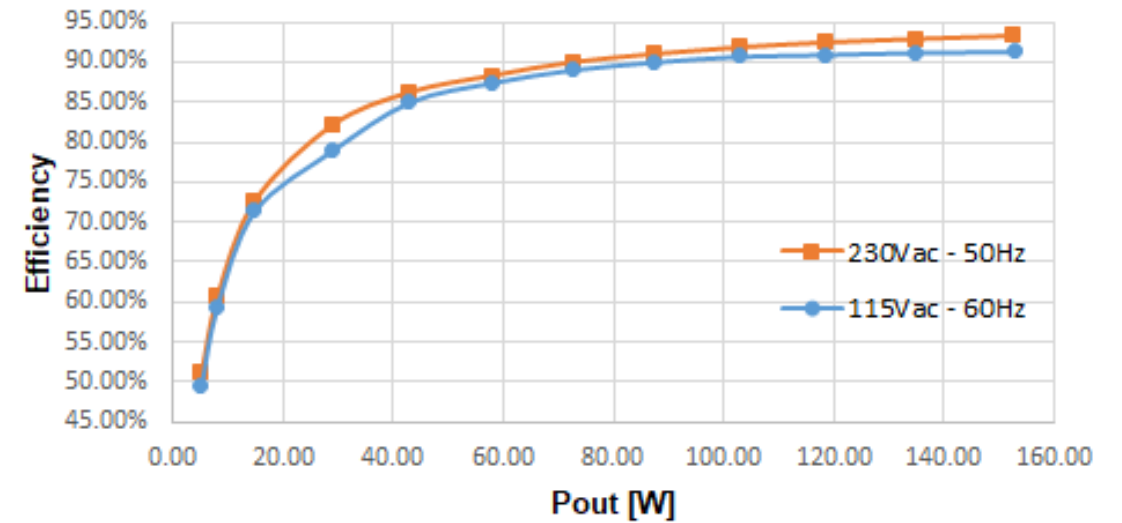

待机功耗

Vin(Vac)	Pin
90V-50Hz	71mw
115V-50Hz	57mw
230V-50Hz	82.8mw
265V-50Hz	115mw
277V-50Hz	120mw



演示板 - 200W TV应用

STNRG011

*Mass Production &
Board available*

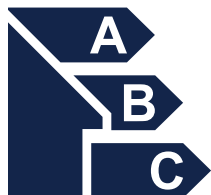

效率最大化

基于STNRG011的200W TV电源演示板



可编程更改和数据监控



全集成

GUI GUI接口更简单实现相关配置



200W TV应用测试报告

115Vac效率测试报告

115Vac/60Hz								
	12V			Back Lighting			Pin (W)	Efficiency
	Vout (V)	Iout (A)	Pout (W)	Vout (V)	Iout (A)	Pout (W)		
No load	12.43			66.5			0.11	
200mW	12.431	0.0161	0.2	76.89			0.40	50%
250mW	12.430	0.0206	0.256	79.01			0.47	54.47%
Full load	12.422	3.9825	49.47	64.85	2.2831	148.06	218.01	90.6%

230Vac效率测试报告

230Vac/50Hz								
	12V			Back Lighting			Pin (W)	Efficiency
	Vout (V)	Iout (A)	Pout (W)	Vout (V)	Iout (A)	Pout (W)		
No load	12.429			65.57			0.13	
200mW	12.429	0.0161	0.2	76.87			0.39	51.28%
250mW	12.429	0.0206	0.256	79.02			0.47	54.47%
Full load	12.422	3.9825	49.47	64.85	2.2831	148.06	212.61	92.3%

200W TV应用测试报告

Audio noise test report

* 麦克风离电源10cm

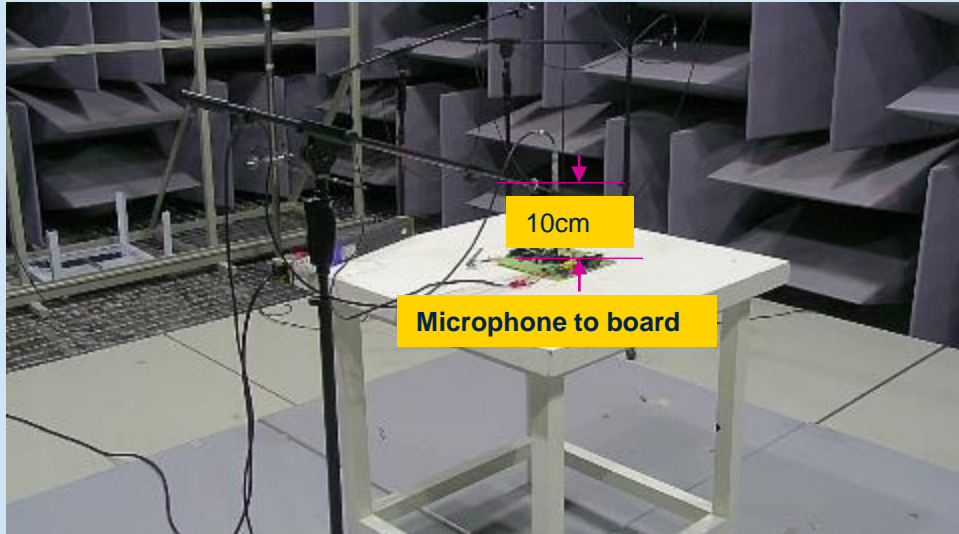

* SPL 测试结果总共是16.592dB(A)

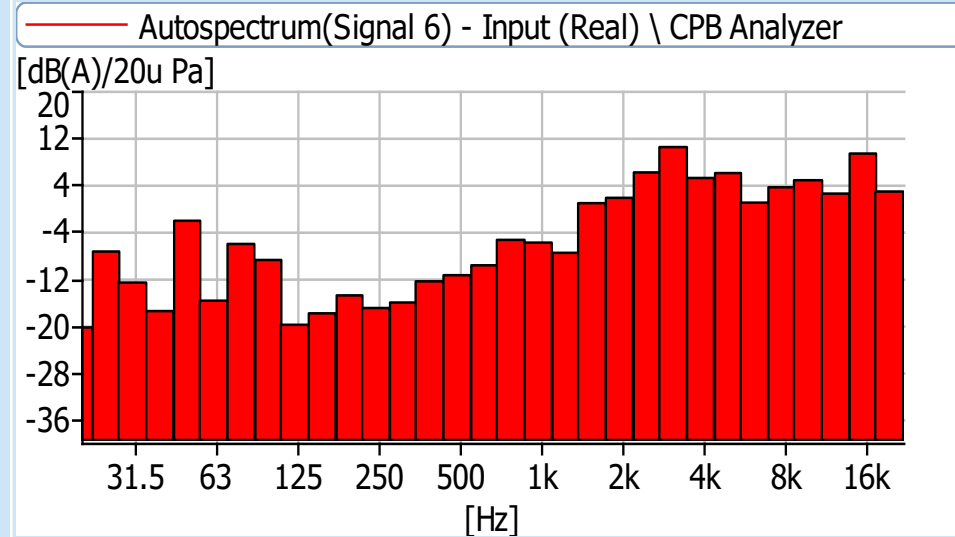

Cursor values
X: 40.000 Hz
Y: -17.593 dB(A)/20u P
Total : 16.592 dB(A)/20u P



演示板 - 200W 电池充电应用

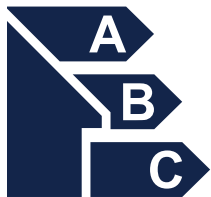

效率最大化

STNRG011/012

量产 & 演示板可供

基于STNRG012的200W 电池充电示板



可编程更改和数据监控

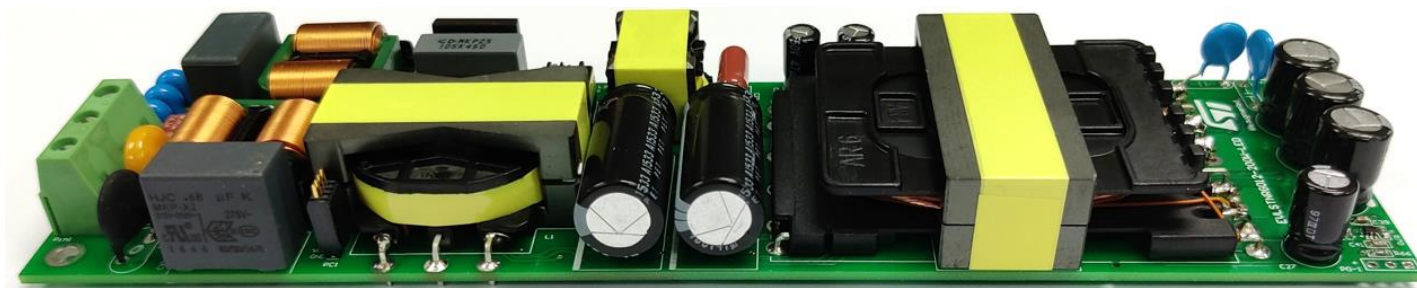

GUI接口更简单实现相关配置



全集成



200W LED路灯应用电源

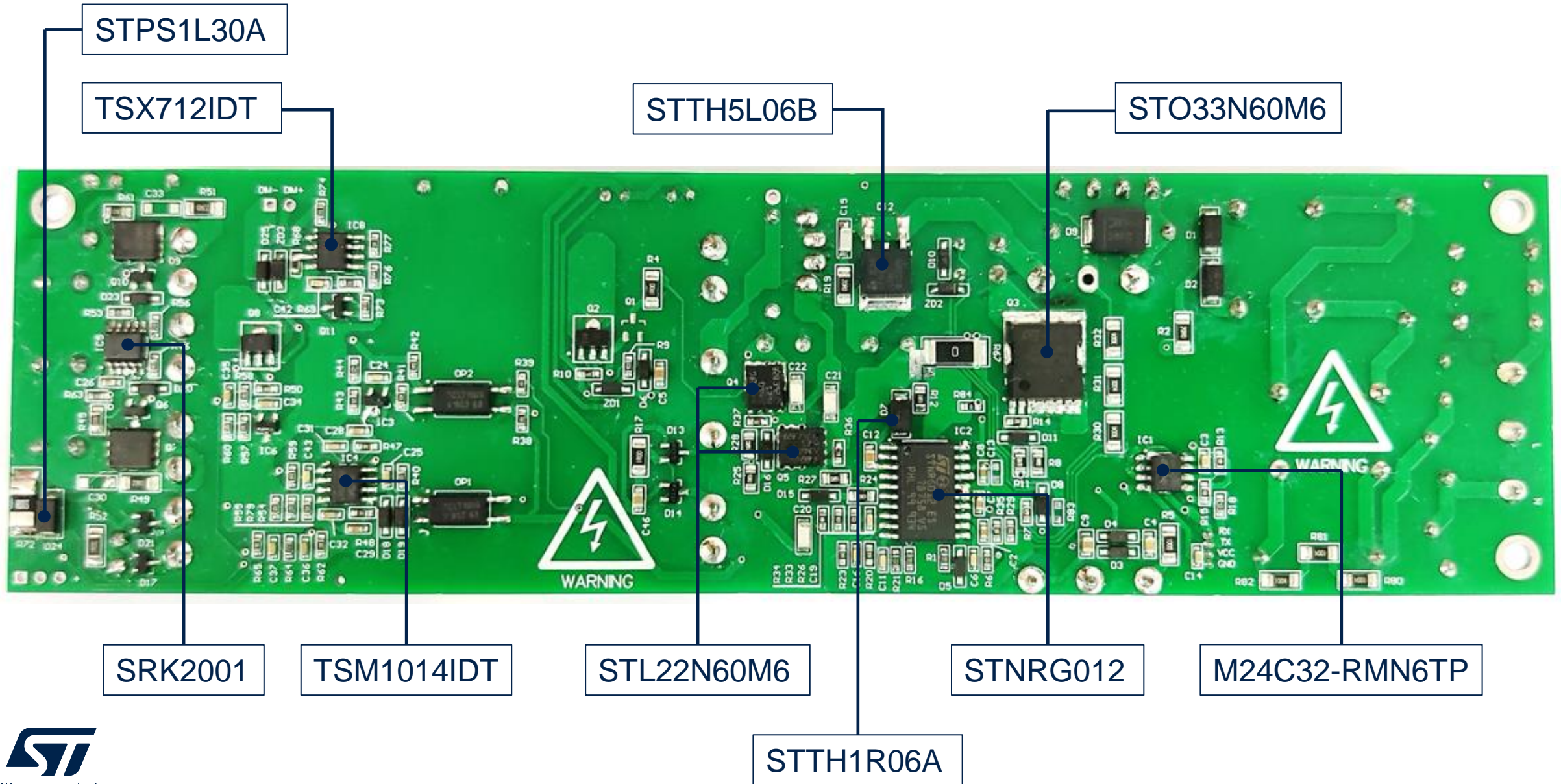

目标规格及主要特点

参数	数值
输入电源范围	90V~305Vac, 频率 45~65Hz 120~430Vdc
输出电压范围	36~56Vdc
全载效率	> 94.5% at 230Vac
最大输出功率	200W
空载电源消耗	< 500mW
三合一调光功能	1 ~ 10V, 10V PWM 信号或电阻
电源谐波符合	EN61000-3-2 C级 and JEITA-MITI, Class-C
EMI	根据 EN55022 Class-B
尺寸	200 x 55 x 15 mm (L x W x H)
PCB	双层, 35um, F4R



**Industrial
Summit 2020**
Shenzhen, China | 2 December
POWERING YOUR INNOVATION



谢谢各位!

© STMicroelectronics - All rights reserved.

ST logo is a trademark or a registered trademark of STMicroelectronics International NV or its affiliates in the EU and/or other countries.

For additional information about ST trademarks, please refer to www.st.com/trademarks.

All other product or service names are the property of their respective owners.



life.augmented