

# 110krpm BLDC for Hair-dryer/ Industrial Applications

Nov 3-2021

Ricky Wen 文豪

*Applications Engineer*

T: +86 755 8250 5406 | M: +86 134 0079 4377

E: RICKY.WEN@arrowasia.com

Arrow Electronics | arrow.com



Arrow proprietary information – Selective Disclosure only

**V** | Five Years Out

# Content

- 1. High Speed Motor Driver for Fast Hair Dryer**
- 2. Ultra High Speed BLDC Motor Driver Platform Introduction**
- 3. Block diagram of Ultra High Speed BLDC Motor Driver**
- 4. Three-phase Hairdryer FOC control mode**
- 5. FOC Hardware block diagram and hardware circuit**
- 6. Development Issues Sharing**
- 7. Fast Motor ON/OFF performance**

# High Speed Motor Driver for Fast Hair Dryer



# Faster airflow to dry up your hair



Shiny Hair



Lower Temperature

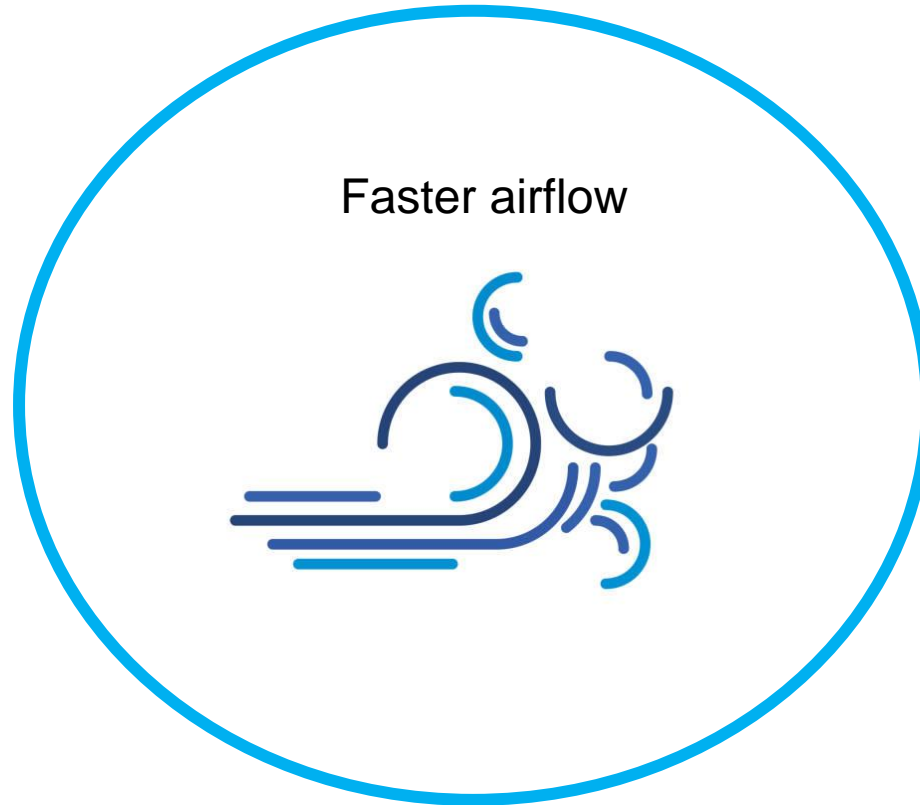

Quick-Dry

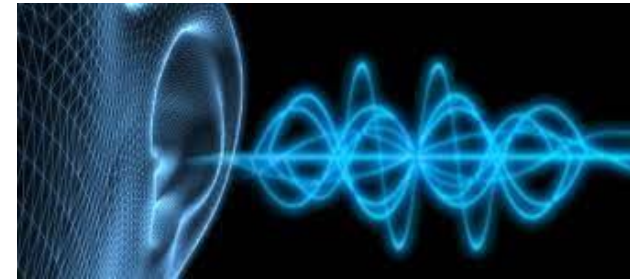

Lower Noise

# Other Applications ...



Vacuum Cleaner



Leaf Blower



juicer

# Ultra High Speed BLDC Motor Driver Platform Introduction

## Description:

This demo board is to demonstrate a high-speed fan driver technology, aimed at hair dryer applications. Using senseless FOC control algorithm, the speed can reach 110000rpm. Moreover, motor startup within one second and stop within 200ms.

## Advantages:

speed and current close loop control, over current protection, quick start, small size and low cost

## Features:

- High speed: Up to 110000rpm
- Quick Startup (0.6s)
- OCP, OVP
- $V_{in}$ : 220Vac ~ 240Vac

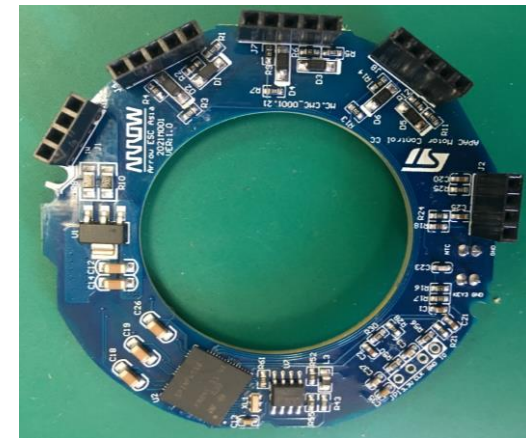
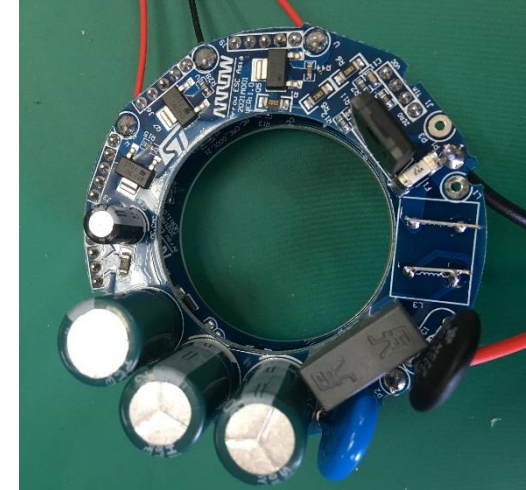

# Block diagram of Ultra High Speed BLDC Motor Driver

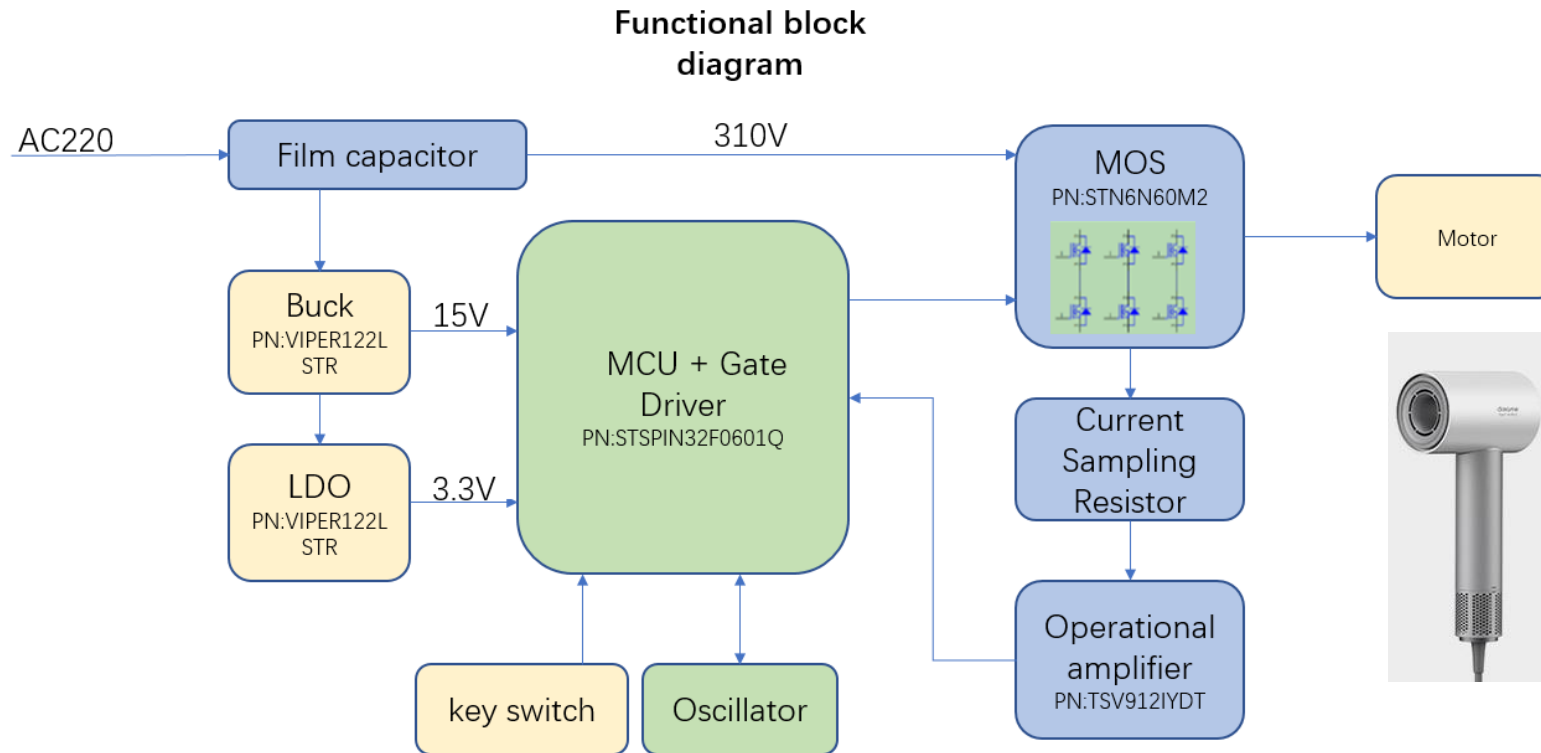

## Main part list:

Suppliers	Part#	Qty
KEMET	PHE840MB6150MB10R17	1
KEMET	ESH107M035AE3AA	1
Littelfuse	047601.6MRSN	1
Murata	CSTNE8M00G520000R0	1
Panasonic	ELC-12D102E	1
ST	BAT41ZFILM	1
ST	STTH1L06A	2
ST	STN6N60M2	6
ST	T1635T-8FP	1
ST	STSPIN32F0601Q	1
ST	VIPER122	1
ST	LD1117S33TR	1
ST	TSV912	1
Defond	DSE-2216T-AWR71-01R	1

# STSPIN32F060x

3-phase BLDC driver with embedded STM32 MCU

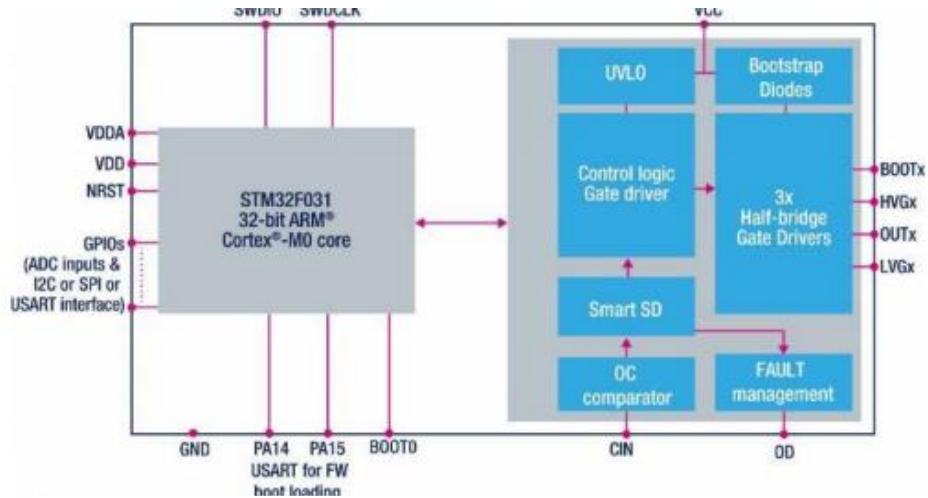

QFN 10 x 10 mm  
(2020年3季度in MP)



TQFP 10 x 10 mm



\* STSPIN32F0601/Q  $\Rightarrow I_{GATE} = 0.35A$   
STSPIN32F0602/Q  $\Rightarrow I_{GATE} = 1A$

## Main characteristics:

- STM32 Cortex M0 + 3-phase driver
- Compatible with STM32 ecosystem
- 6-step & FOC sensorless / sensor algorithm
- Robust negative voltage capability
- VS=600V, I=350mA & 1A current capability
- 48MHz, 32k Flash & 4K SRAM
- 12-bit ADC
- I2C / UART / SPI; 21 GPIOs
- FW bootload supported
- Bootstrap diode integrated
- Fully protection (UVLO, short-circuit, OCP)
- Wide temperature range -40 to 125°C
- TQFP & QFN 10 x 10 mm package

## Main application:

- HA and industrial fridge compressor
- Industrial pump
- A/C compressor and fan
- High power tools, gardening tools
- White HA
- Industrial automation



# Three-phase Hairdryer FOC control mode

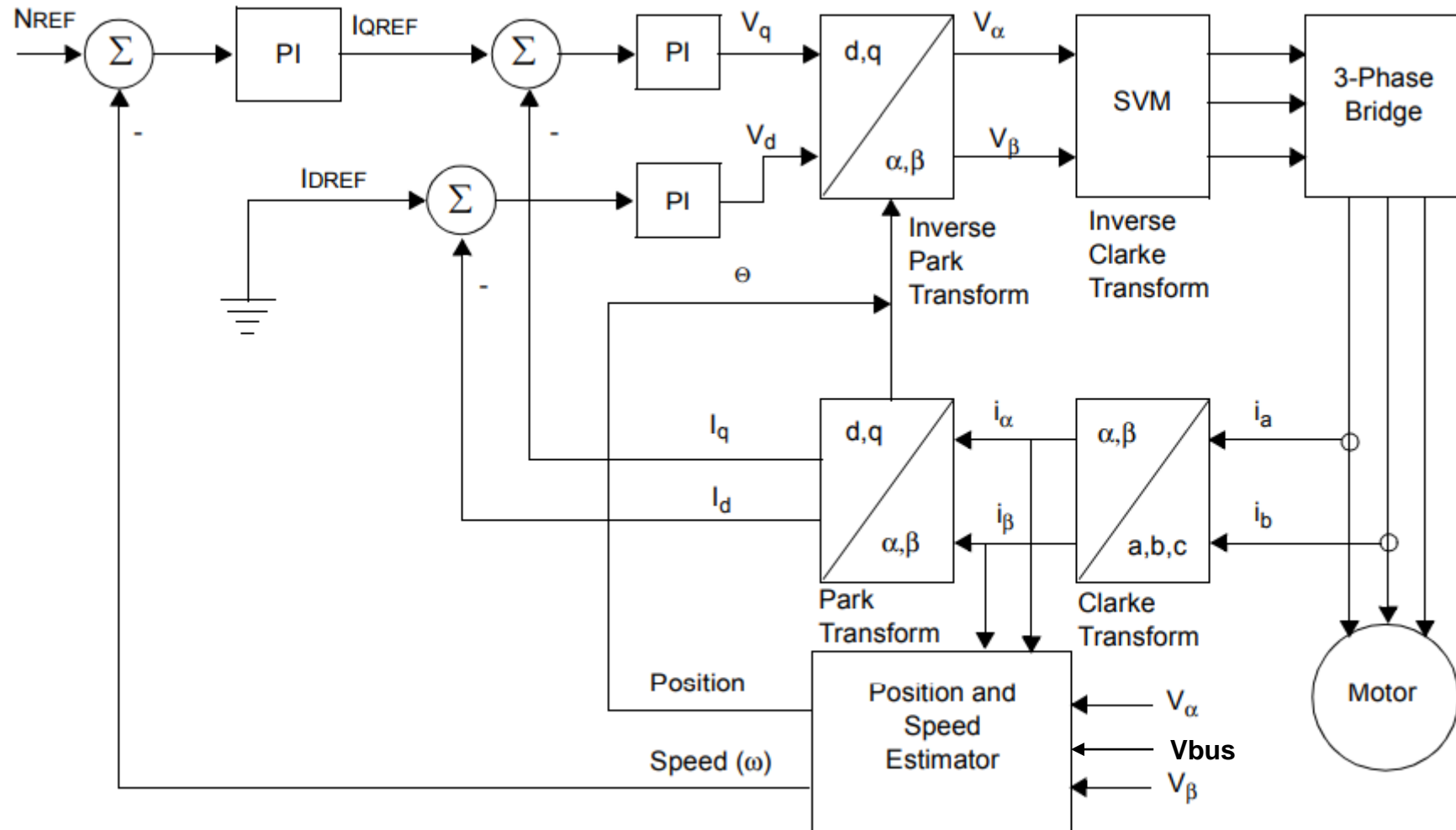

# FOC Control Hardware block diagram

## FOC current control loop circuit:

AC-DC and DC bus rectifier circuit design

Phase current sampling circuit design

3-phase inverter circuit design

Motor position feedback circuit design

# Three-phase current detection & amplification

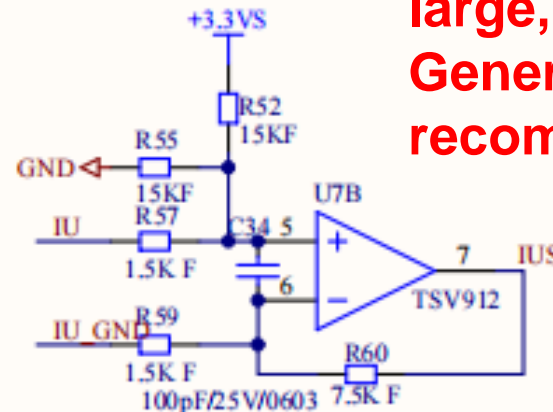
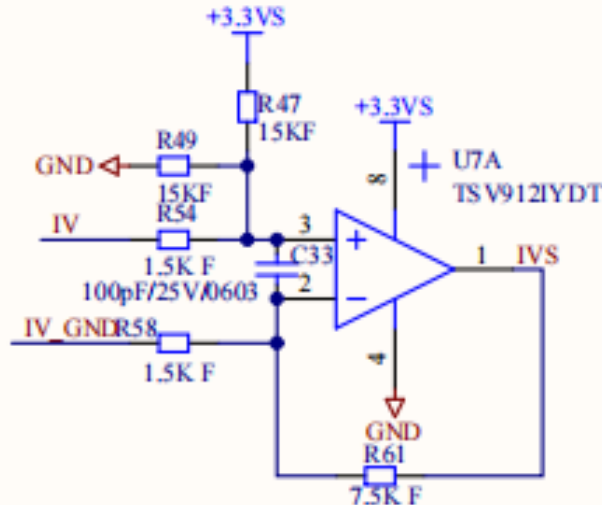
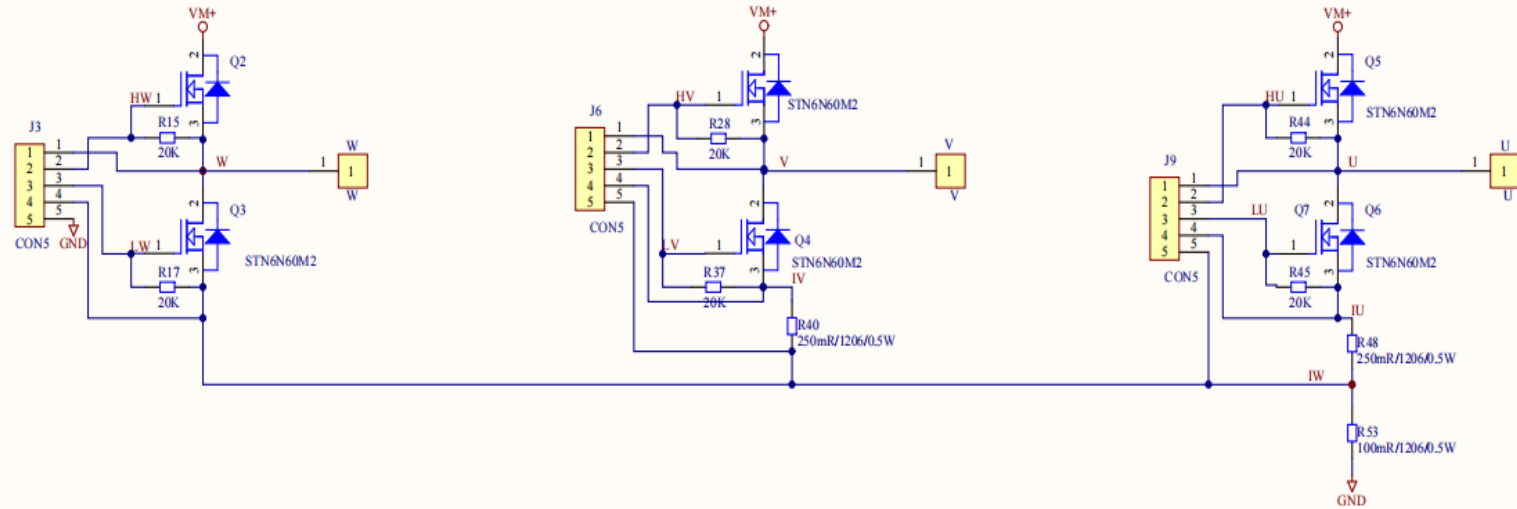

**Note: if the amplifier gain is too large, noise will be introduced. Generally, 5 ~ 10 times gain is recommended**

# Development Issue 1 – Layout Noise

Independent  
Differential  
Connections for  
Current Sensing

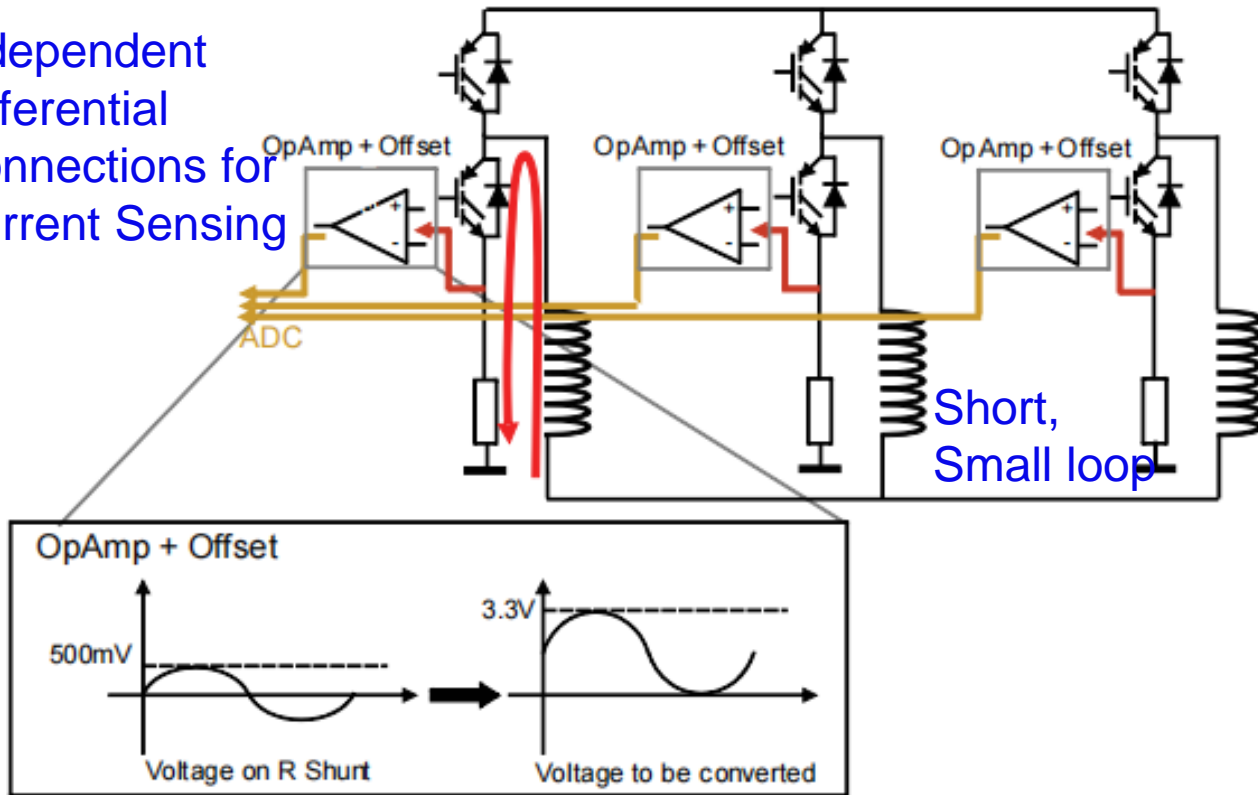

- > Sensorless FOC algorithm relies solely on **current signal sampling**
- > To Avoid any control issues, Need
  - > **Clean** Auxiliary Power Supply DC Output
  - > **Short, small loop** of Main power lines
  - > **Independent** Differential Connections for current sensing,
    - > no sharing of the signal ground,
    - > avoid passing through high power circuits

# Development Issue 2 – Control Loop Stability

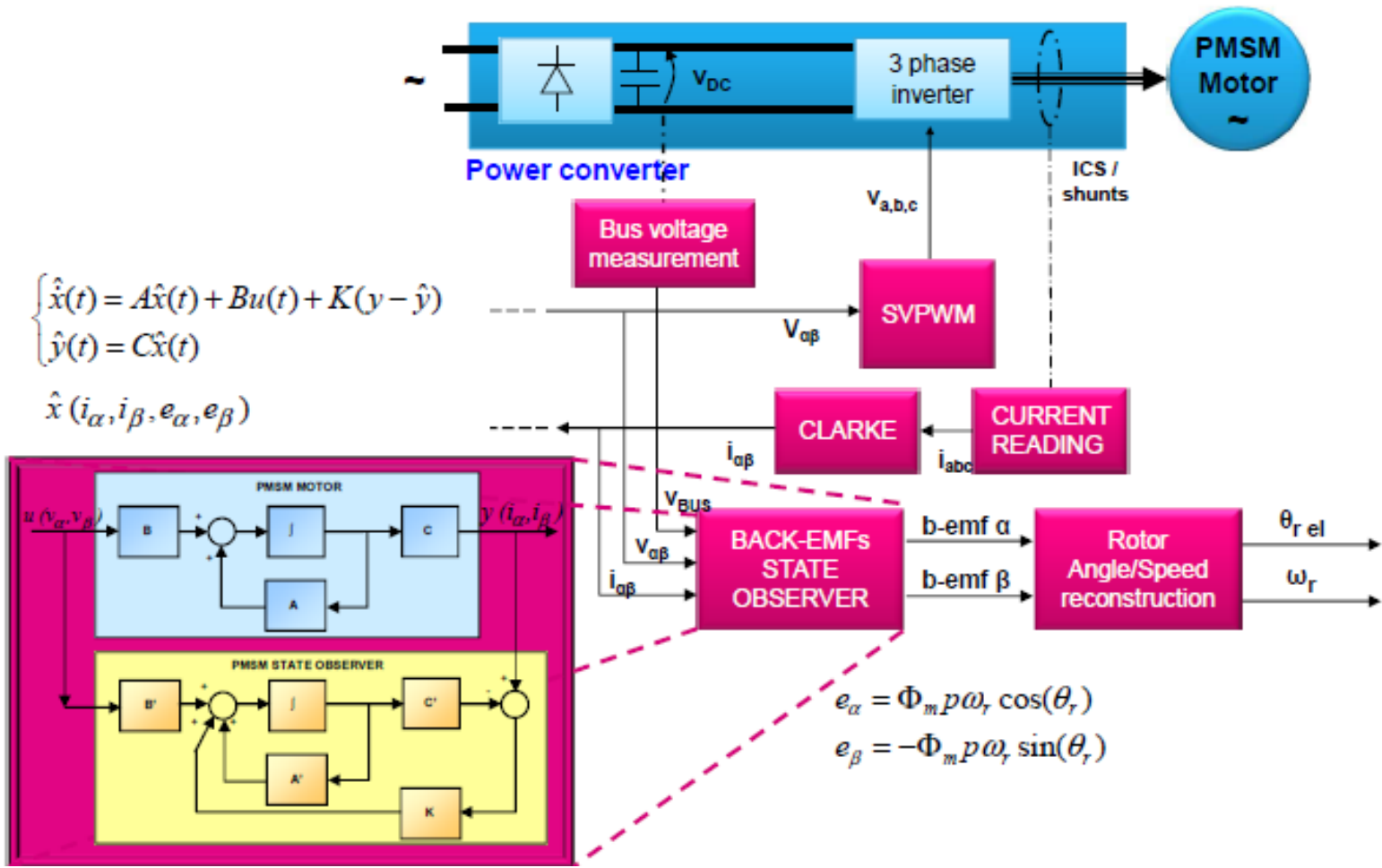

> To increase loop stability, Need multiple trials & debug the following loops:

- > Current loop bandwidth (KP, KI)
- > Speed loop bandwidth (KP, KI)
- > Observer Gain (G1 G2)
- > PLL bandwidth (KP, KI)

Parameter interaction needs Internal and external joint tuning

# Development Issue 3 – Slow Startup

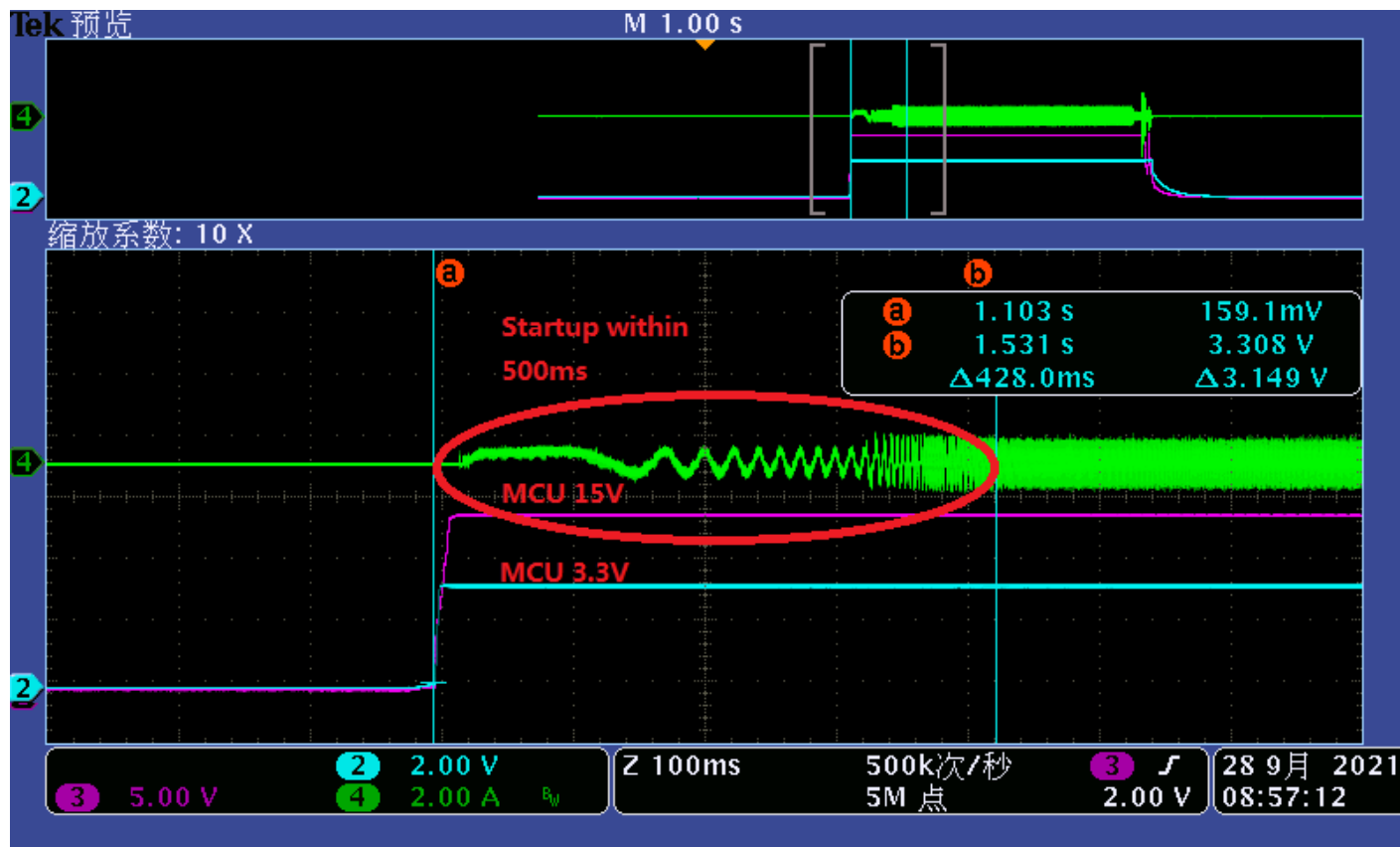

- > To avoid slow startup, Need **MCU with Strong Libraries** for
  - > Change the acceleration curves
  - > Increase bandwidth and increase loop response speed
  - > Reduce positioning and open loop switching time

Start-up at 22kg Pressure Difference

# Fast Motor ON/OFF performance

1)

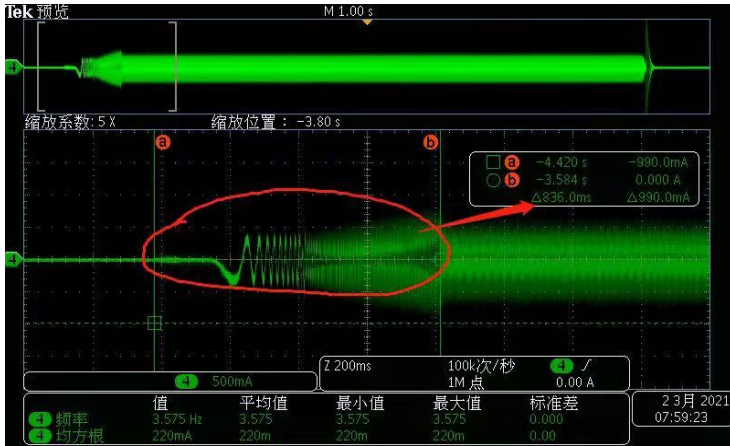

- Start to full speed within - 1S

2)

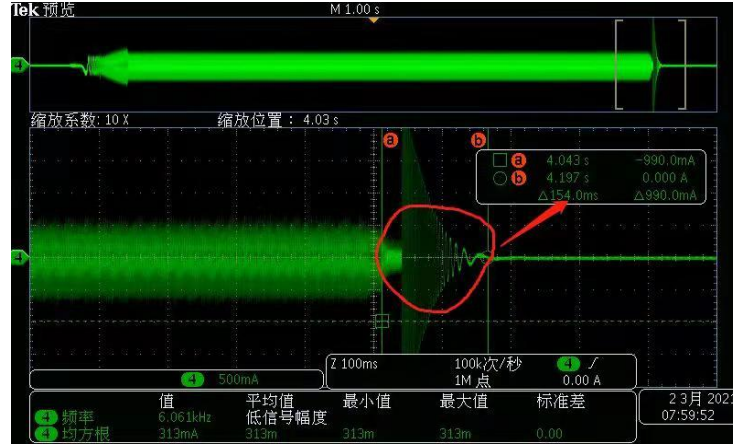

- Motor speed drops from 110Krpm to zero within 200ms

3)

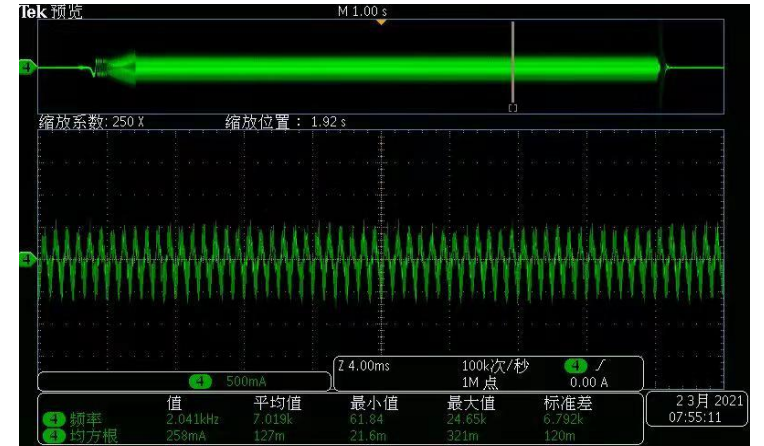

- steady state at 110KRPM

4)

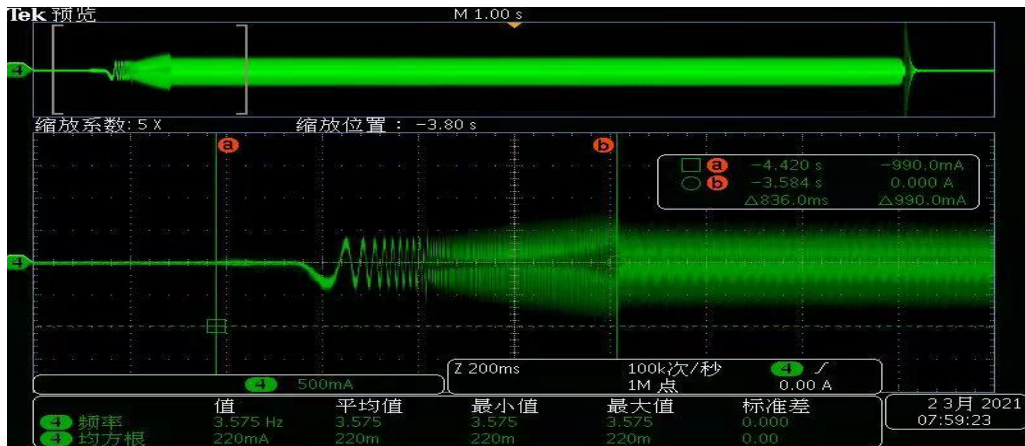

- Start to full speed, then run in a steady state, and finally quickly stop the whole process waveform

# Evaluation kit and live demo video

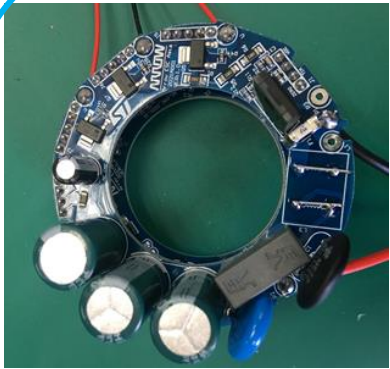

Power Board

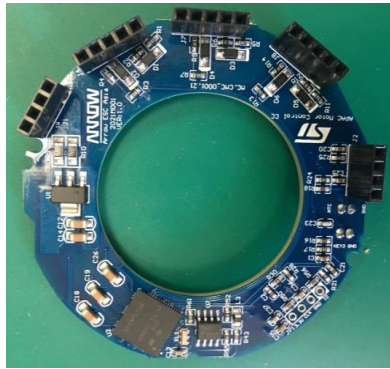

Control Board



110 krpm Motor

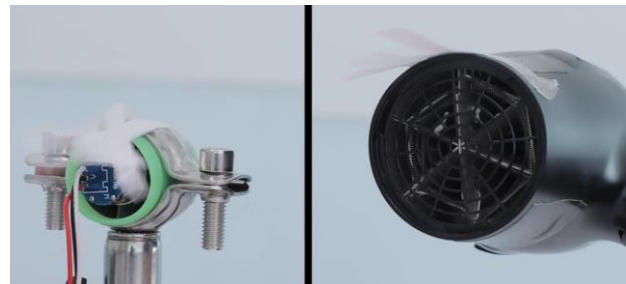
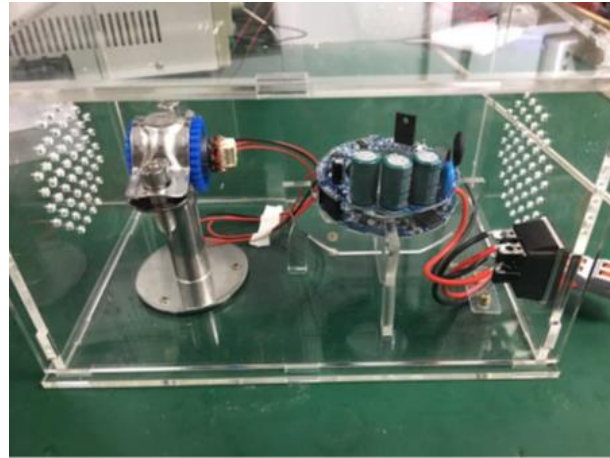

110krpm vs 20 krpm

【艾睿方案】大风量低噪音的高速吹风机电机驱动方案

原创 艾睿电子 艾睿电子 昨天



吹风机是家中必备的小家电，看似平凡无奇，但随着技术的进步，转速更高、噪音更低的电机，使吹风机有了新的发展。本文将为您介绍由艾睿电子所推出的新款高速吹风机电机驱动方案，将如何改变吹风机的设计方式。



Super-fast hair-dryer Demo Video



YOUKU



微信扫一扫  
关注该公众号







# Thank You