



Compact, high-efficiency LED driver using 700 V smart power GaN (OmniGaN™)

Rosario Attanasio
STMicroelectronics

Rosario.Attanasio@st.com



1 GaN for LED drivers

2 OmniGaN™ product family

2.1 Product selection and features

2.2 Application details

2.3 PFC and Flyback use cases

3 240W OmniGaN™ LED driver

3.1 Specifications

3.2 Topology and design details

3.3 Characterization results

4 Conclusions

The benefits of GaN in lighting applications

Benefits of GaN for lighting applications

- Reduced power losses
- Smaller luminaire form factor
- Improved reliability and lifetime
- Cost-effective system design

Why GaN is worth it for LED drivers

- 2-3% efficiency improvements vs. Si-based solutions
- Possibility to double the power density even for <300W
- Better PF and iTHD%
- No heatsinks and cooling fans required for <300W
- Enhanced ROI through energy savings





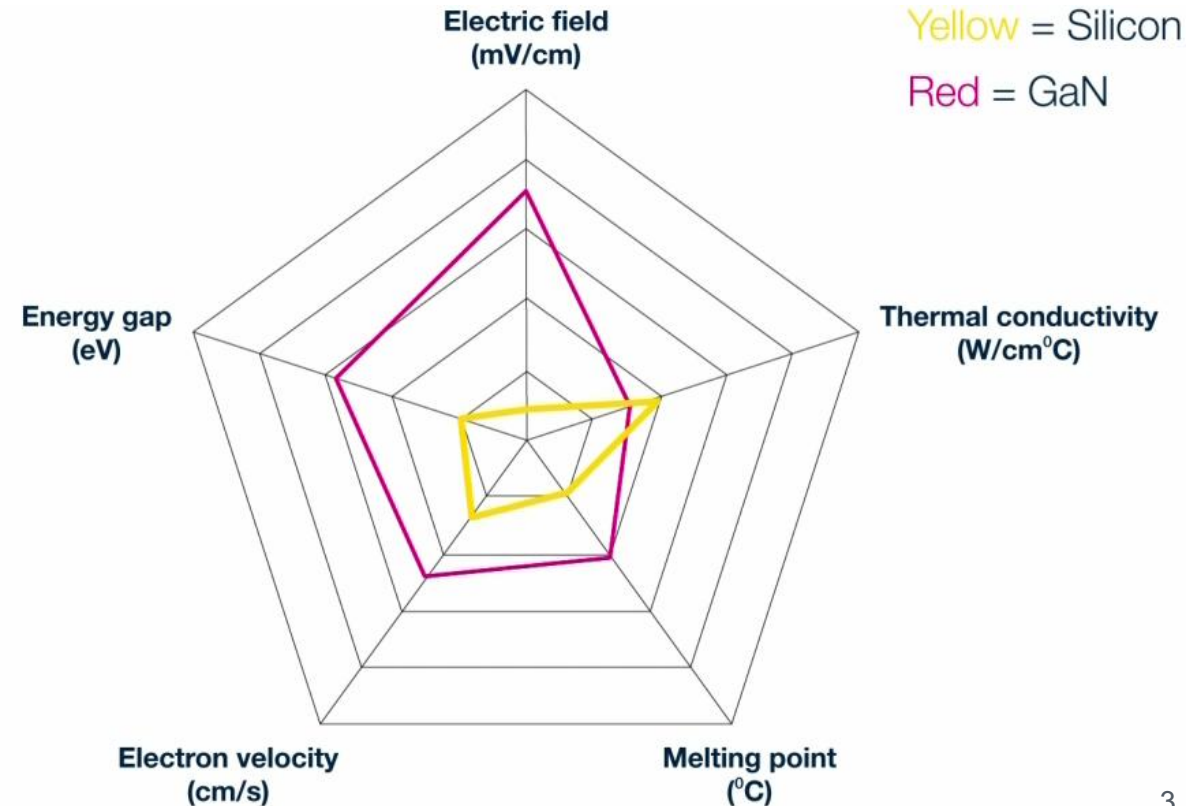

Benefits of GaN



GaN LED drivers

Where GaN really adds value in lighting power supplies

Power rating	Topology	Typical applications	Power quality	GaN recommended?	Key GaN benefits	Notes Vs Si	
10W -50W	Buck, Flyback	Indoor lighting	PFC required above 25W	Not recommended	Cost and complexity outweigh the benefits	Use Si MOSFETs; GaN only for niche, ultra-compact premium lamps	
50W -150W	Flyback/ HPF Flyback + Buck	Commercial panels, downlights	PFC required	Optional	Marginal efficiency and size gains	Consider GaN only where driver height/volume is very constrained	
150W-300W	PFC+LLC, PFC+2SW-Flyback, PFC+Hybrid Flyback, PFC+ACF	Street-lights, floodlights, industrial ceiling lights	PFC required	Recommended	Higher efficiency, better power density, reduced thermal stress	OPEX savings in outdoor/professional lighting can offset GaN cost	
300W-1000W	PFC, Inter. PFC, LLC+buck, LCC	Stadium lights, hort. lighting, stage lights	PFC required	Strongly recommended	Large loss reduction, thermal advantage	Often enables smaller heatsinks, quieter/no fans, higher reliability	
> 1000W	Interleaved PFC, LLC+Buck, LCC	High bay lights, UV lights, projectors	PFC required	Best fit	Maximum efficiency, thermals, EMC	GaN well suited to high-power, high-duty professional systems	

New 700V ST OmniGaN™ features



700V ST OmniGaN

Self Protected E-Mode GaN HeMT with Wide Gate Input Voltage Range

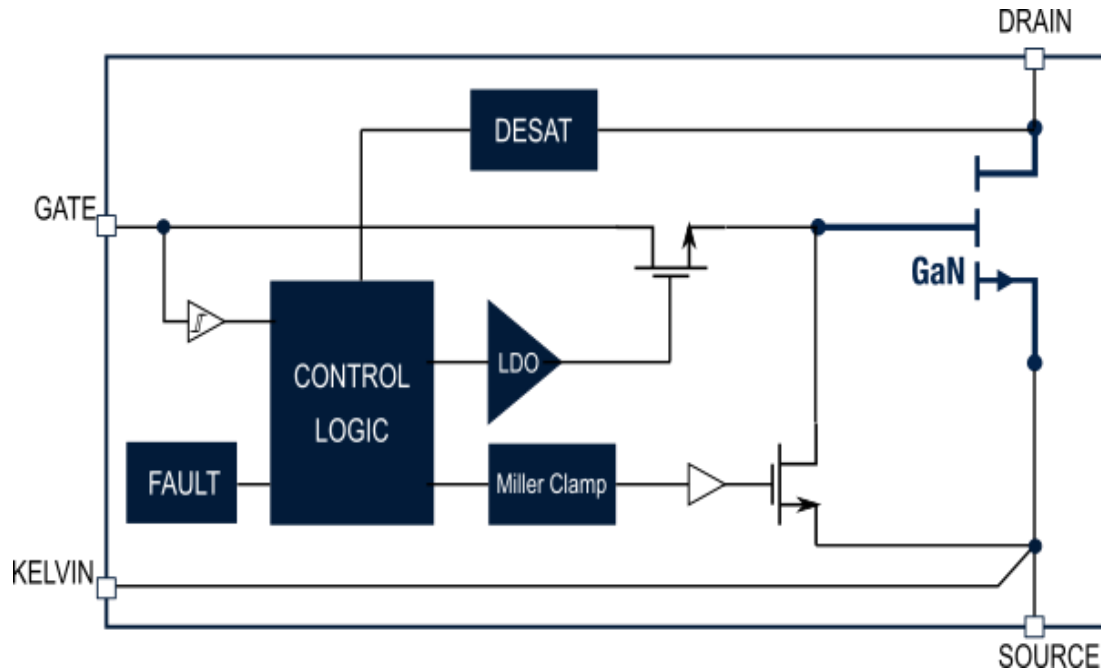

Key features:

- E-mode GaN with integrated Gate Clamp
- Wide 10V to 24V Gate input voltage range, compatible with standard Si/SiC drivers
- Integrated Miller Clamp
- Paralleling Capability
- Adjustable turn-on and turn-off Slew Rate
- High Frequency operation up to 2 MHz
- DESAT, UVLO, and OTP protections
- 700V GaN HEMT with $15\text{ m}\Omega_{\text{typ}}$, $25\text{ m}\Omega_{\text{typ}}$, $42\text{ m}\Omega_{\text{typ}}$, $32\text{ m}\Omega_{\text{typ}}$, $55, 77\text{ m}\Omega_{\text{typ}}$

Applications:

- High-Power Switching Power Supply
- AC-DC, DC-DC, DC-AC Converters
- Solar Micro Inverter, Motor Drive, OBC



TO-LL



TOLT

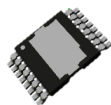

QDPAK

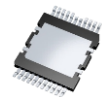

Driving STOMNIGAN

- STOMNIGAN is driven by any driver having a driving voltage (V_{drv}) between 10V and 24V.
- Negative supply is not necessary
- Two resistors, R_{G_ON} (10 Ω to 33 Ω) and R_{G_OFF} (2 Ω to 10 Ω) adjust drain slopes

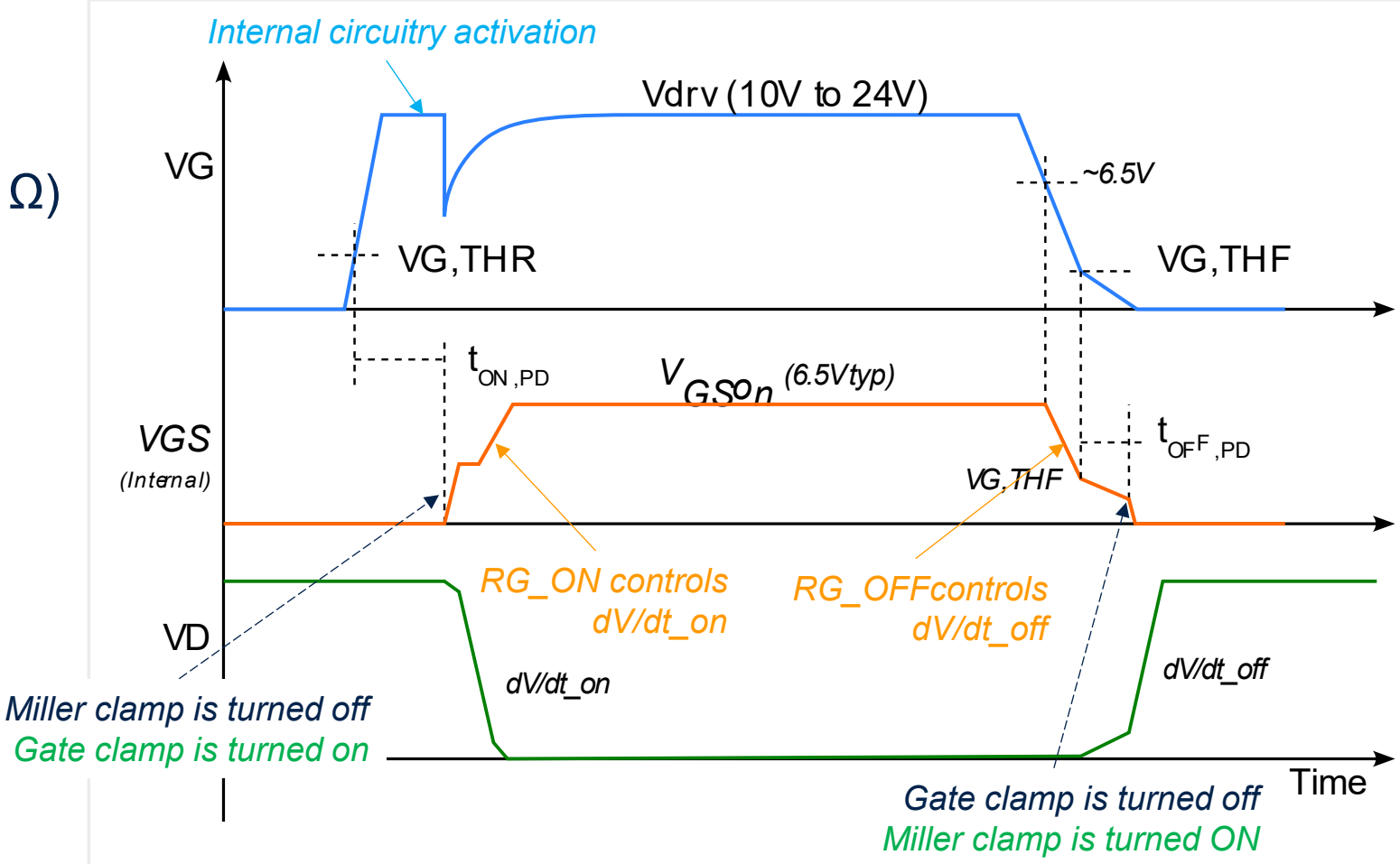
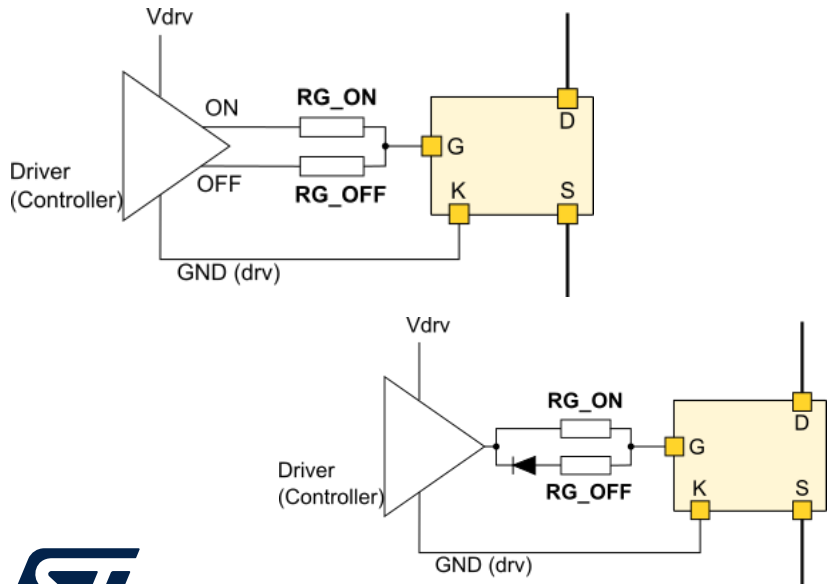

STOMNIGAN Miller Clamp

- Miller clamp consists of an internal 0.5Ω N channel transistor that forces the internal VGS to zero in the following conditions:
 - $V_G < V_{G,THF}$ – avoiding insufficient driving
 - Protection (OTP / Desat) triggering – to safely force GaN off
 - Excessive drain dV/dt – to avoid induced turn-on when a half / full bridge configuration is there

Standard solution: No Miller clamp or external MC FET, turn on of high side GaN induce low side GaN turn on at steep dV/dt .

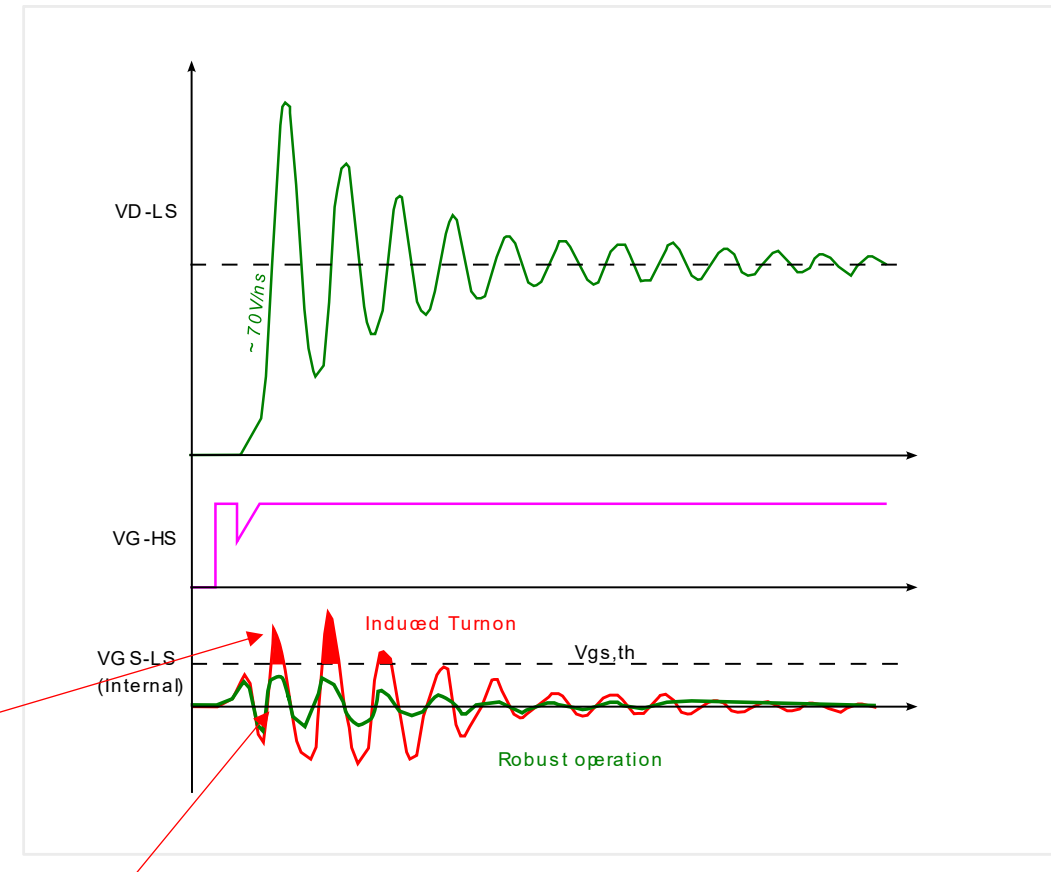

STOMNIGAN: integrated Miller clamp ensures a stable turn-off state even in presence of dV/dt induced oscillations

DESAT protection

- STOMNIGAN embeds DESAT protection that forces the GaN off with Miller clamp on if VD surpasses $V_{D,DESAT}$ value.
- Protection remains latched until VG is pulled down
- Protection is effective against overloading or short circuit (reaction time $\sim 300\text{ns}$)

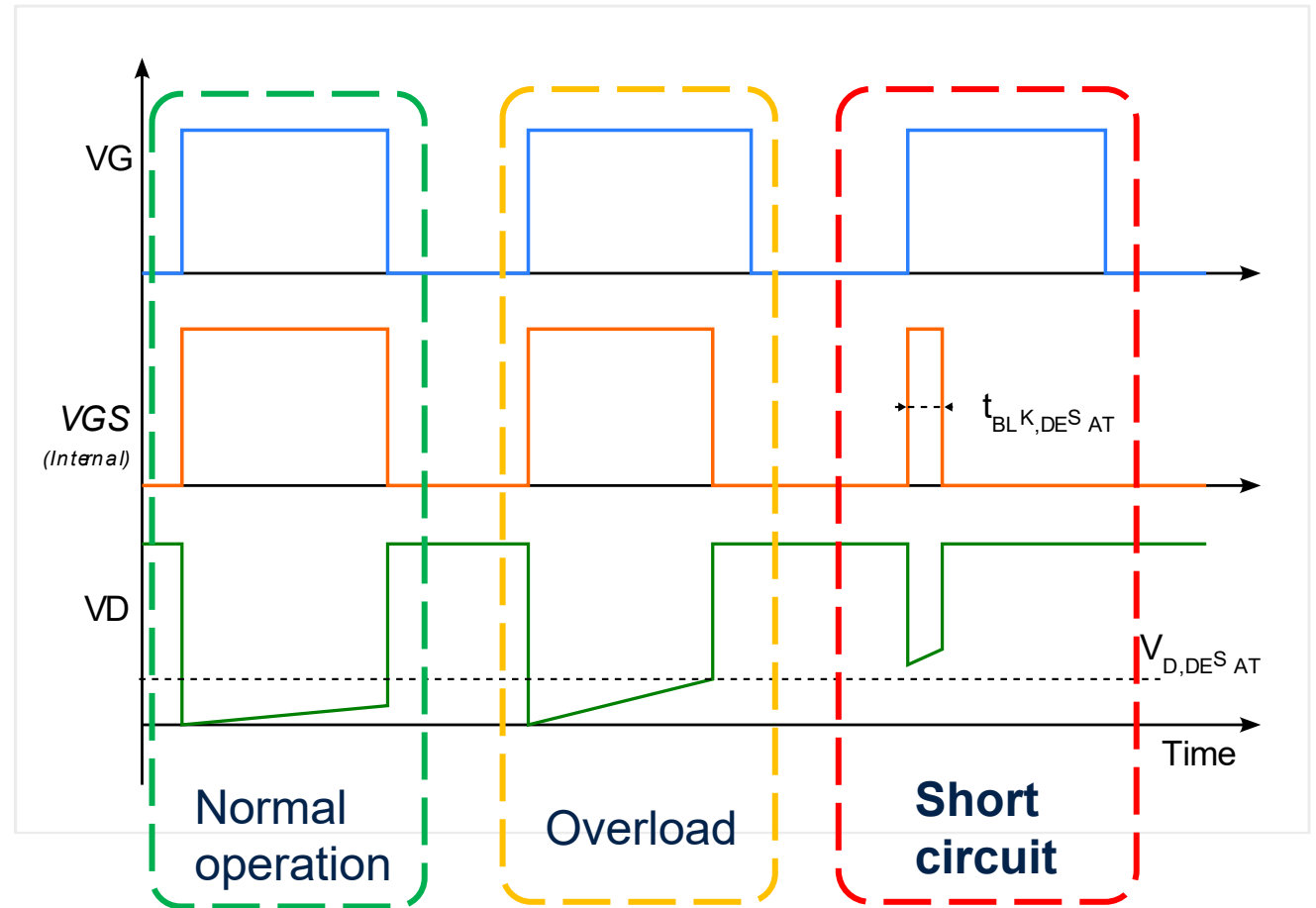

STOMNIGAN OTP

- STOMNIGAN embeds Over Temperature Protection (OTP) that forces the GaN off with Miller clamp as soon as GaN temperature is measured above T_{OTP} (160°C typ).
- Protection remains latched until the temperature decreases by at least T_{HYS} (20°C).
- The GaN switching activity is enabled again at first valid rising edge on VG.

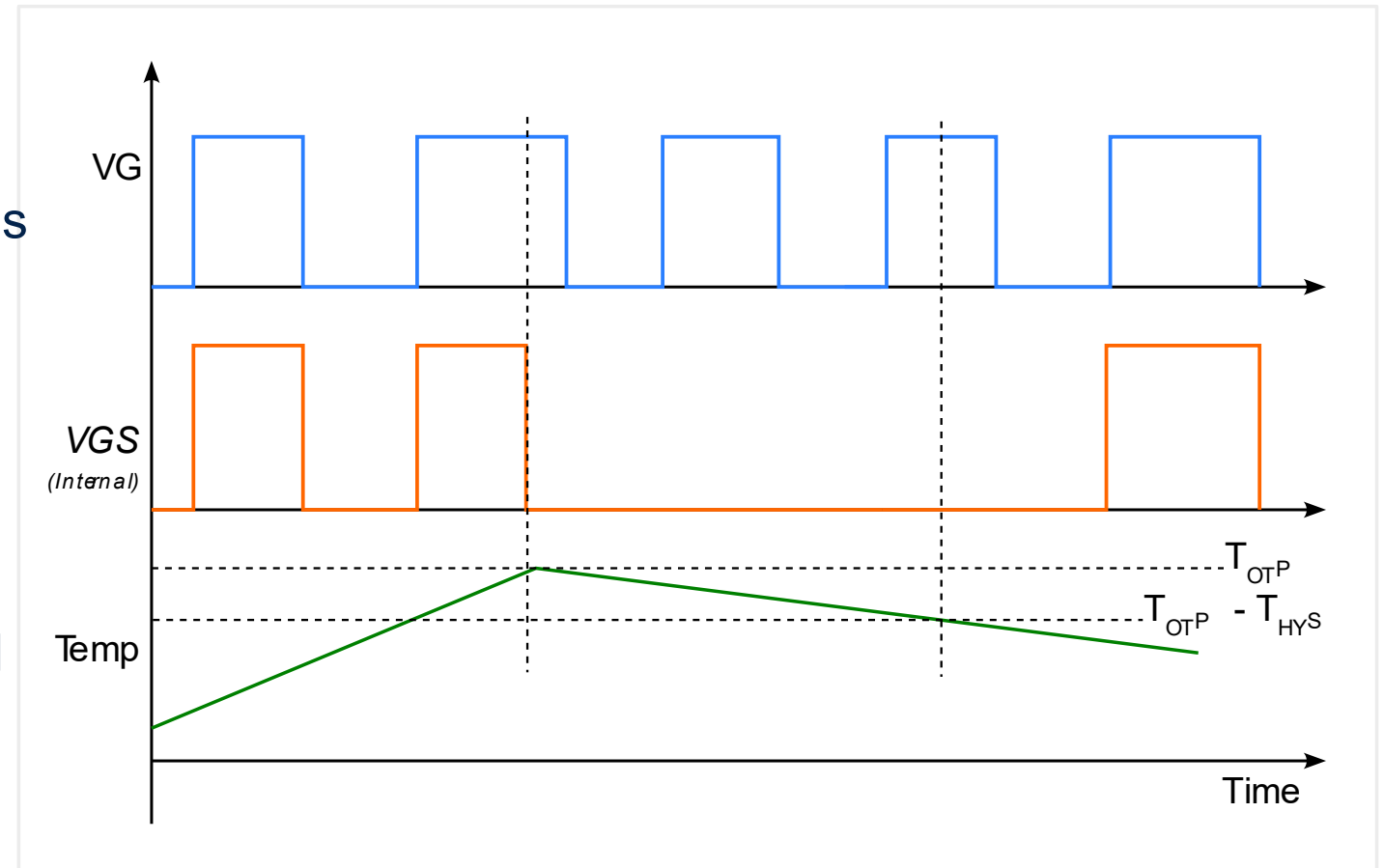

Driving ST OmniGaN™



Driver selection for STOMNIGAN

- **STDRIVEG600** → useful to interface microcontrollers or digital outputs with STOMNIGAN in medium/high power half bridge topologies.
 - Very simple bias design including integrated bootstrap diode
 - Very robust operation thanks to floating low side section and powerful drivers
- **STGAP2 / STGAP2D** → useful to interface microcontrollers or digital outputs with STOMNIGAN in very high-power half bridge topologies where galvanically isolated driver section is required
 - Galvanically isolated drivers
 - Wide range of output combinations



SO-16

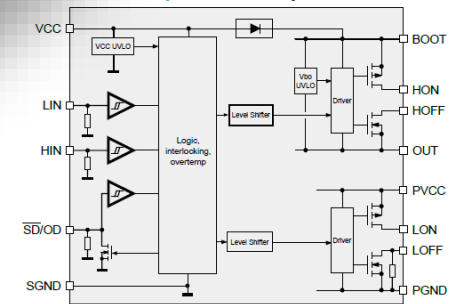

SO-8

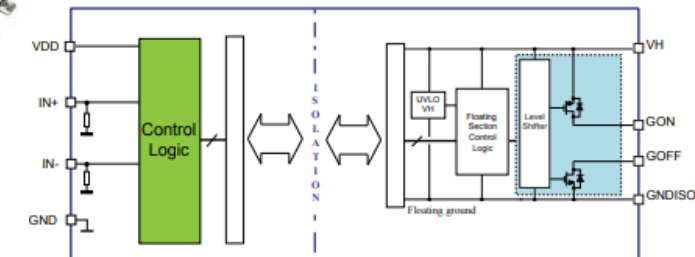

Smarter solutions for high power topologies

Isolated drivers required when $V_{bus} > 520V$ (functional isolation)

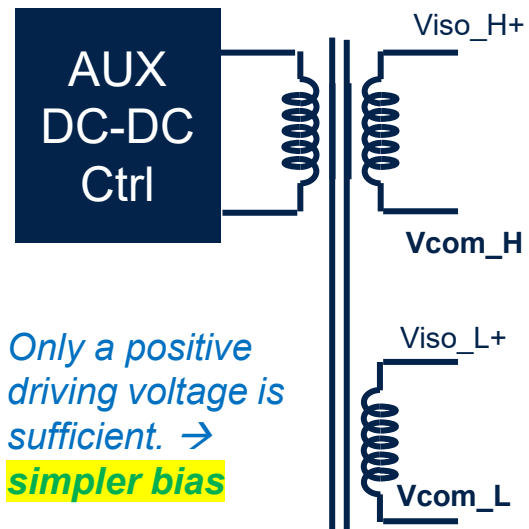

Only a positive driving voltage is sufficient. → **simpler bias**

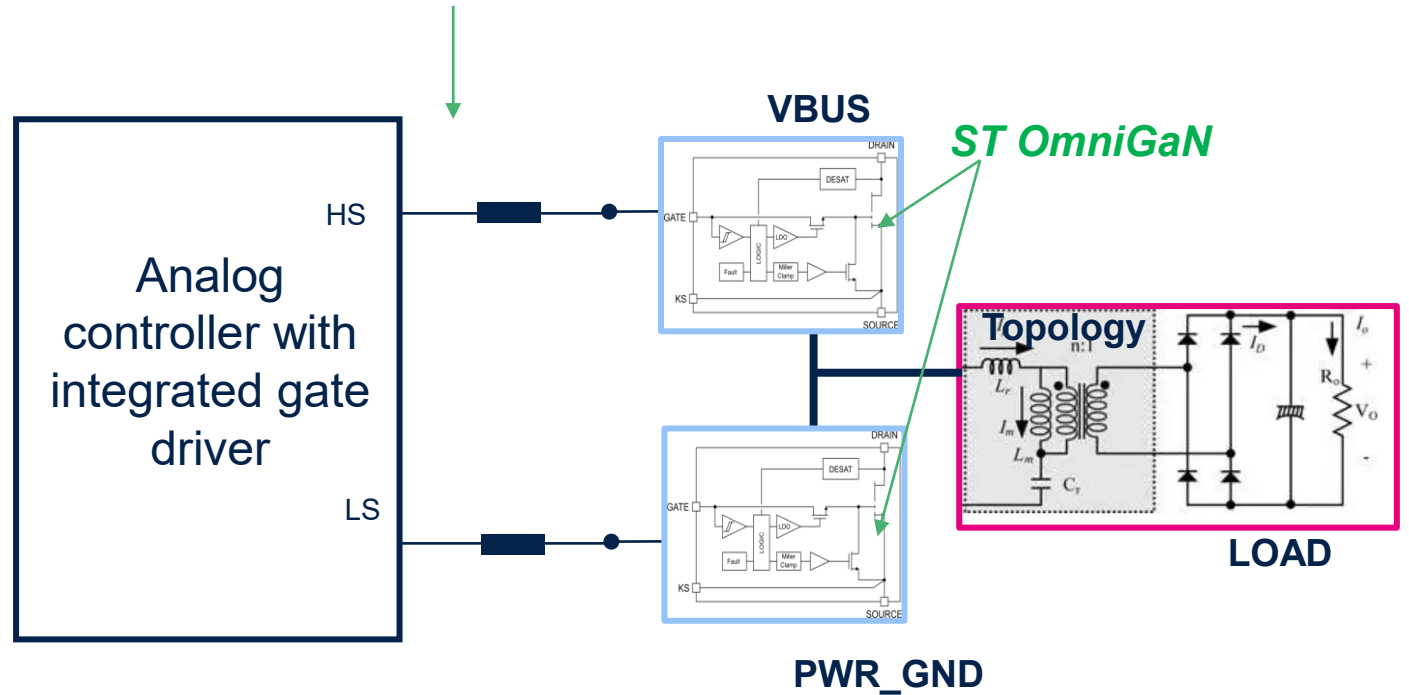

- **ST OmniGaN integrates local protection and operates with unipolar driving only.**
- While the driving inputs still require a high source capability driver, a simple HI/LO side Driver IC can be used, simplifying the overall design.

ST OmniGaN Use in PFC applications

With L4985A/B CCM PFC controller

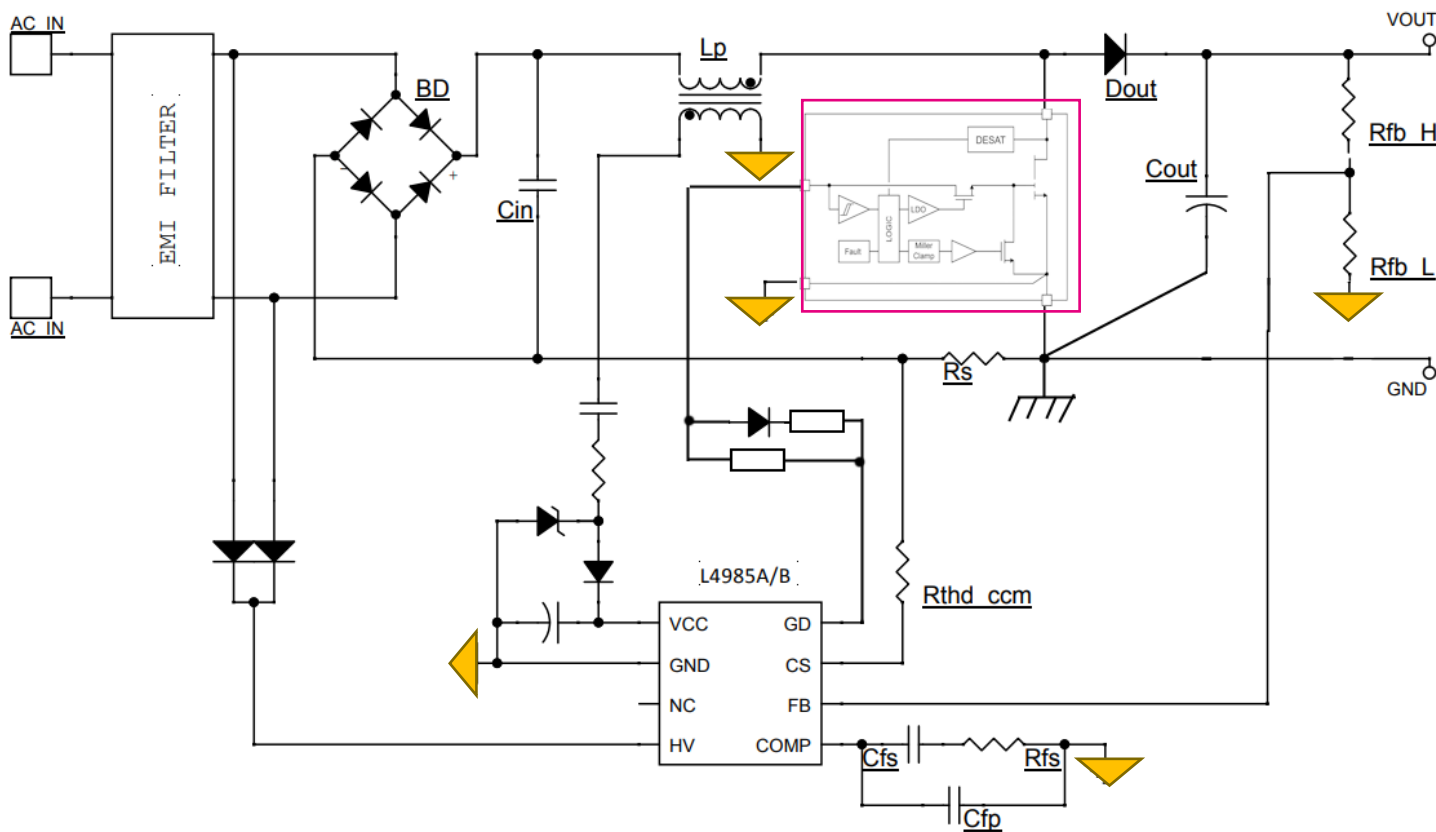

Application schematic with L4985A/B PFC controller

- STOmniGaN driving voltage and network
 - same as the one used for MOSFET
 - unipolar PWM (0 = off, 15 V = ON)
 - $R_{on} = 15 \Omega$, $R_{off} = 2.7 \Omega$
- Kelvin source pin collects ground signal (yellow triangles) creating ground star with GaN source net

ST OmniGaN Use in 2SW-Flyback applications

With STCH03 QR flyback controller + gate pulse transformer

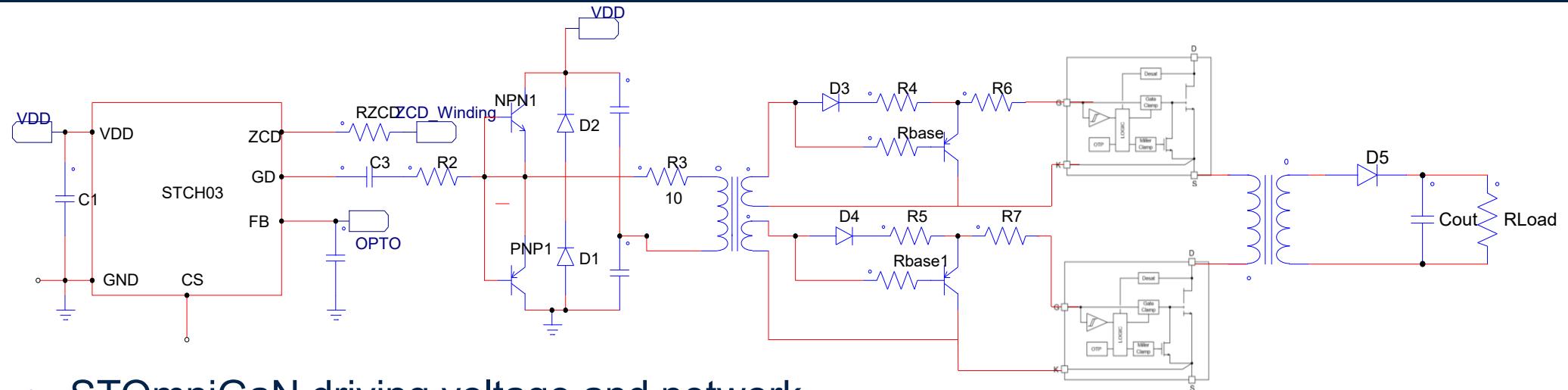

- STOmniGaN driving voltage and network
 - 13V PWM generated by STCH03 controller
 - Totem pole driving pulse transformer +7.5V/-7.5V
 - Pulse transformer turns ratio $N_p/N_{s1}/N_{s2}=1:1.4:1.4$
 - Unipolar PWM (0 = off with PNP, 10V-20 V = ON)
 - $R_{on} = 12.7 \Omega$, $R_{off} = 2.7 \Omega$
- Kelvin source pin and gate pin connected to secondary winding of pulse transformer

240W LED driver with ST OmniGaN™



240W OmniGaN LED driver

CCM PFC + 2SW-Flyback DC-DC

Specification	Value
Input voltage	95-305VAC
Line frequency	50/60Hz
Output voltage	15-48V
Max output current	5.5A
Nominal LED current	5A
Minimum LED current	0.2A
Power density	~25.4W/inch ³
PCB dimensions	97x55x28 mm(LXWXH)
Enclosure type	Sealed
Cooling	No fan or heatsinks



PCB top view

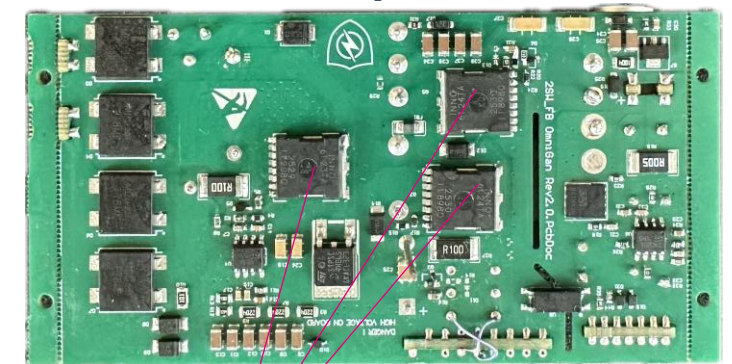

PCB bottom view

700V/55mΩ OmniGaN TOLL



Input Waveforms

120VAC & 277VAC– 48V/5A output

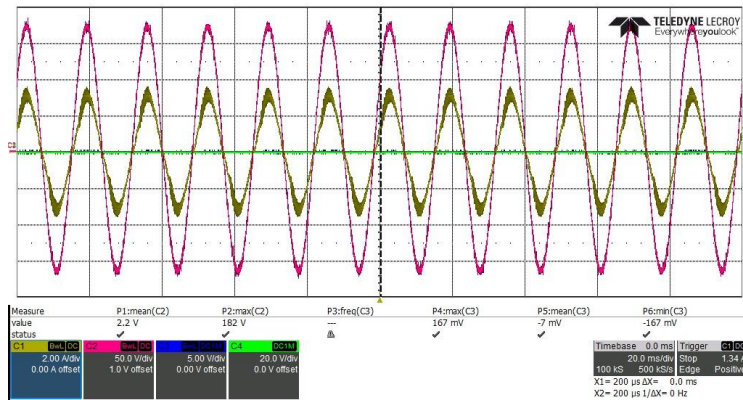

120VAC, 400V DC bus input full load:
CH1 (yellow, input current); Ch2 (purple) input voltage

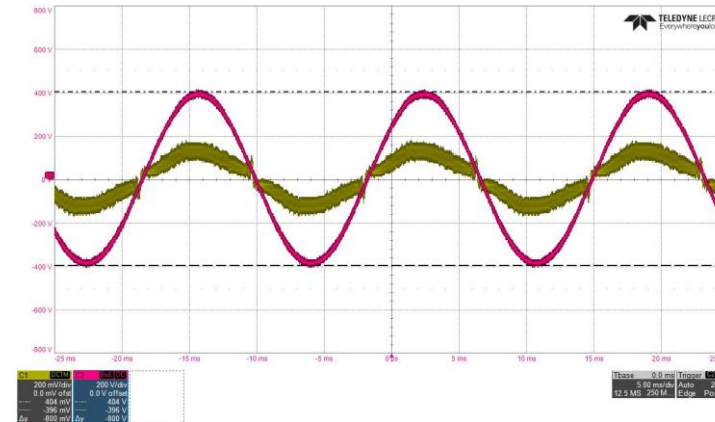

277VAC input, 450V DC bus full load:
CH1 (yellow, input current); Ch2 (purple) input voltage

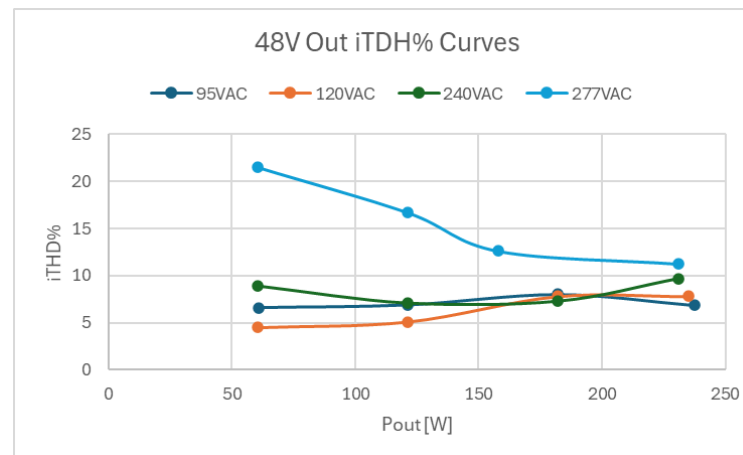
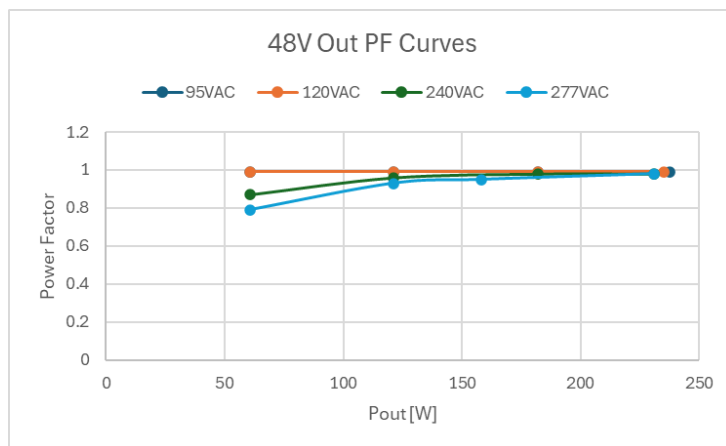

Test results: efficiency

95VAC, 120VAC, 240VAC, 277VAC input

48V Output Efficiency Curves

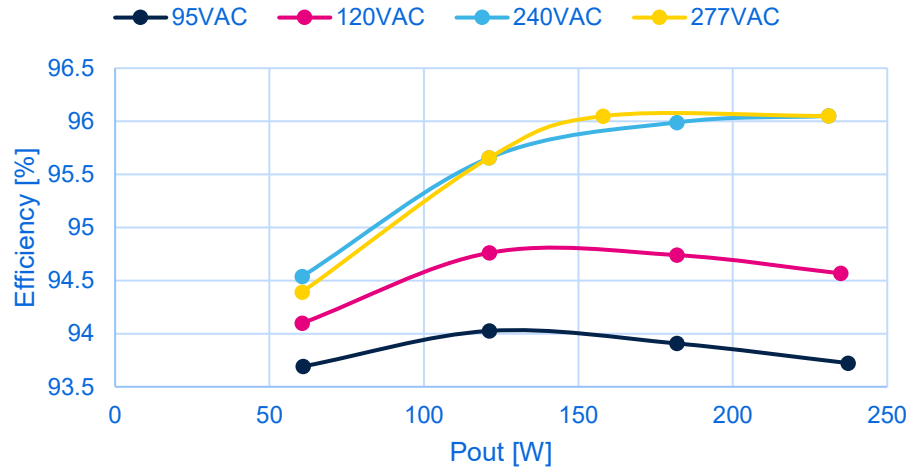

36V Output Efficiency Curves

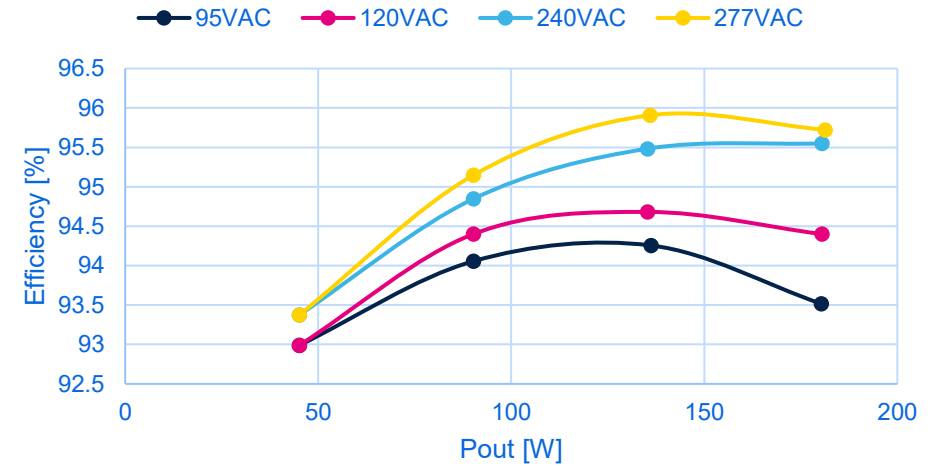

28V Output Efficiency Curves

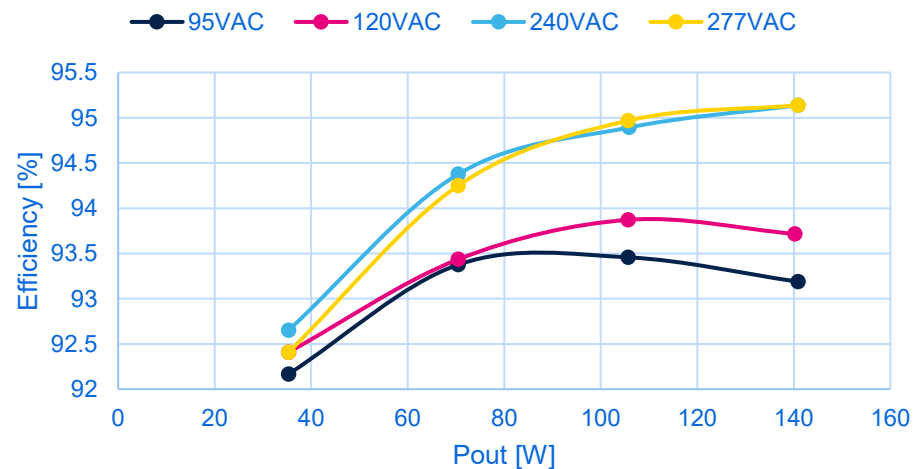

15V Output Efficiency Curves

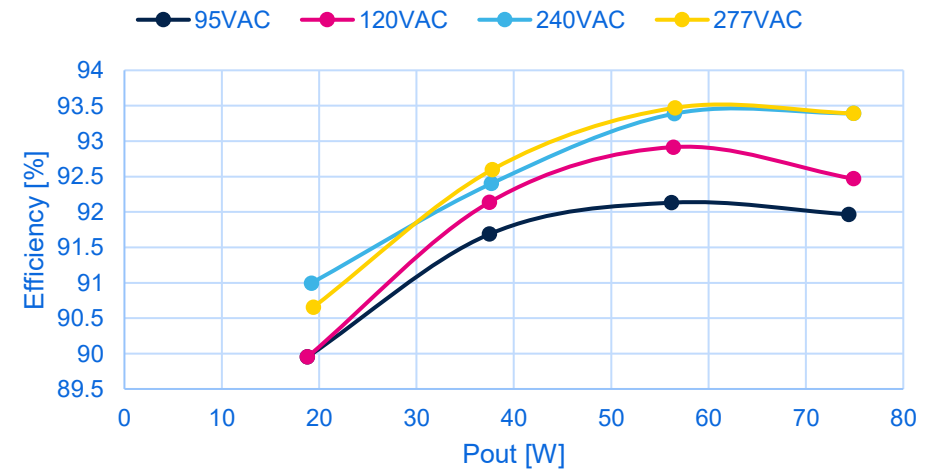

Components temperatures

Open frame thermal test – Tamb=25 C

PFC components

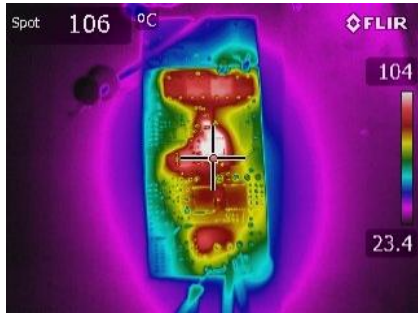

OmniGaN

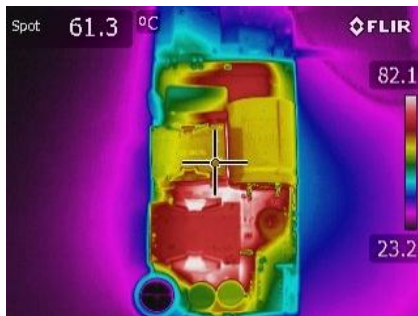

PFC inductor

**@ 95VAC input
48V/5A out**

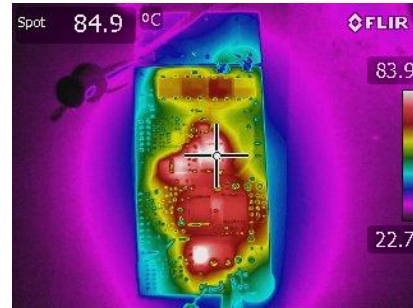

OmniGaN

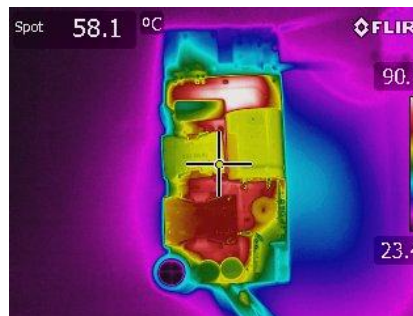

PFC inductor

**@ 277VAC input
48V/5A out**

2SW- Flyback components



Flyback OmniGaN

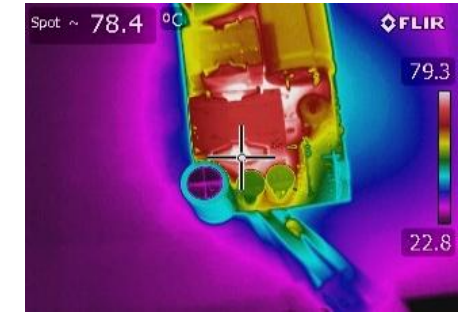

**Transformer core:
68C; winding 78.4C**

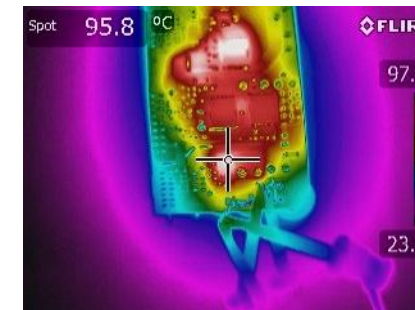

Flyback SR FET

**@ 440VDC input
48V/5A out**

Average efficiency

Average efficiency comparison with Si FETs for 48V, 36V, 28V, 15V

120VAC Input - Average Efficiency OmniGaN Vs Si

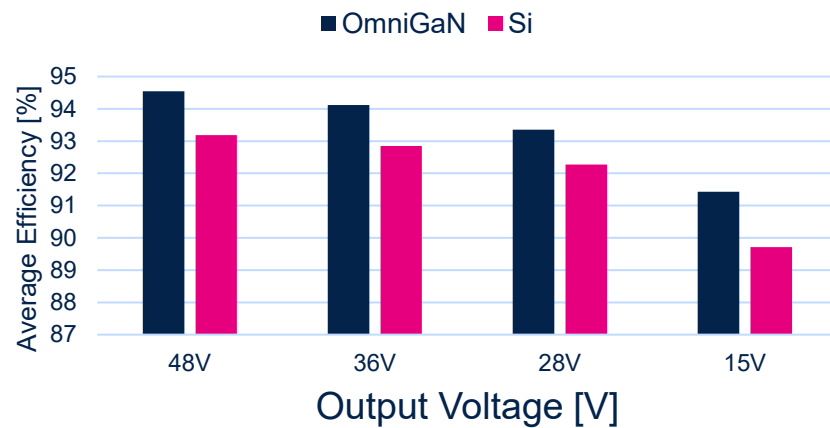

240VAC Input - Average Efficiency OmniGaN Vs Si

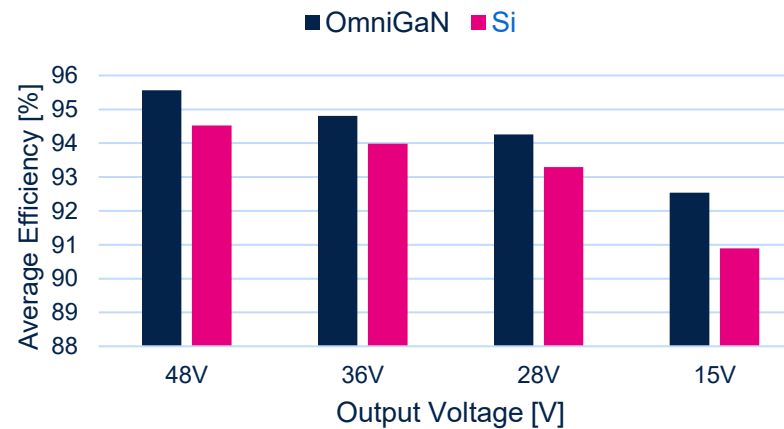

277VAC Input - Average Efficiency OmniGaN Vs Si

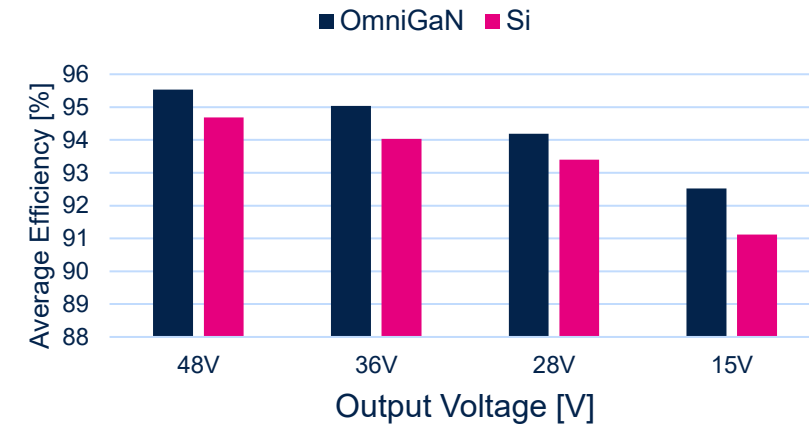

Conducted EMI test

120VAC – 48V@5A load – pass with good margin

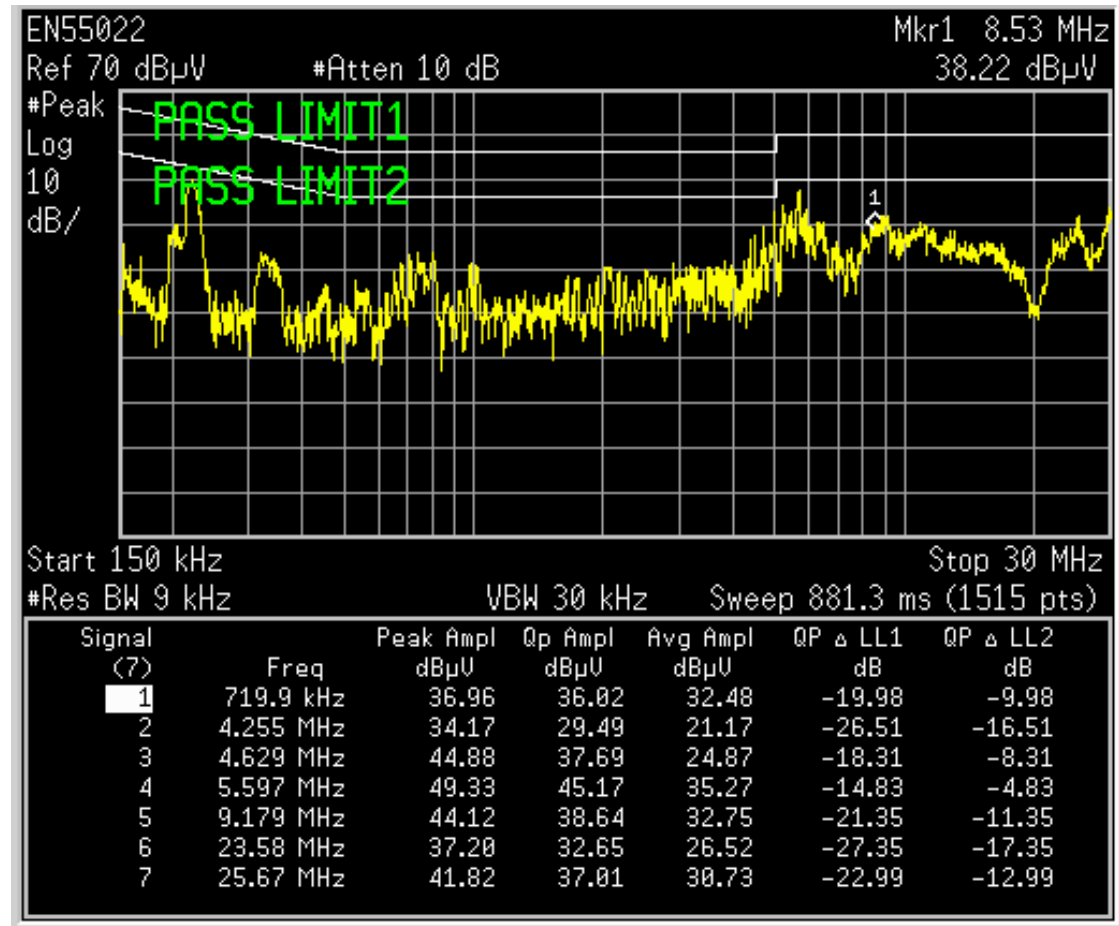
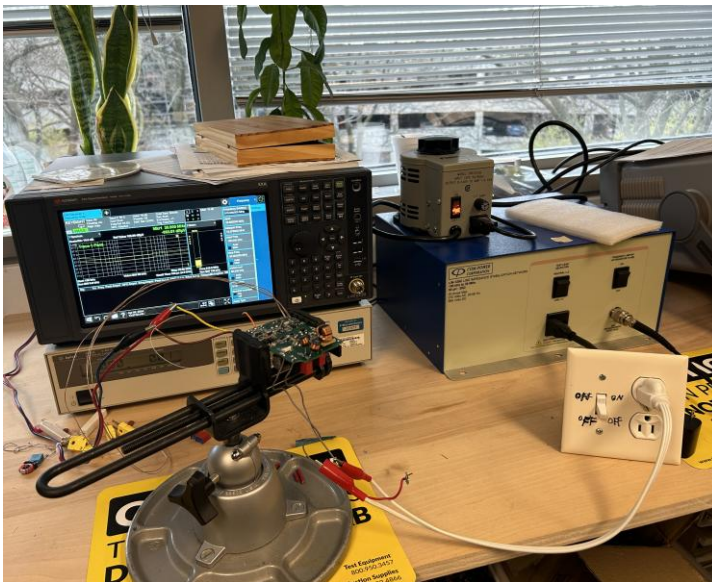

Conclusions

96%

Peak efficiency with ST OmniGAN 55mΩ

Size

Savings and reliability as it can be used with no

Cost

heatsink, standard analog controllers, and has

Reliability

low operating temperatures

Up to 2%

Higher average efficiency compared to Si solution

Small form factor

Cost-effective BOM

Simplified use

Key benefits of the 240W OmniGaN-based LED driver solution

Our technology starts with You

Visit us at booth
#1719

© STMicroelectronics - All rights reserved.

ST logo is a trademark or a registered trademark of STMicroelectronics International NV or its affiliates in the EU and/or other countries.

For additional information about ST trademarks, please refer to www.st.com/trademarks.

All other product or service names are the property of their respective owners.

