

SLIC based system protection for European and Asian markets

Introduction

Even with the boom of the digital technologies and the wireless systems, telecom analog lines remain the most used link to carry speech around the world. Following telecom deregulation the market, traditionally managed by national telecom administrations, is now open to new operators. This makes for an increase in new applications using this simple and cost effective way to supply speech signals.

Figure 1. Classic analog telecom system topology **Figure 2. New telecommunication system topology**

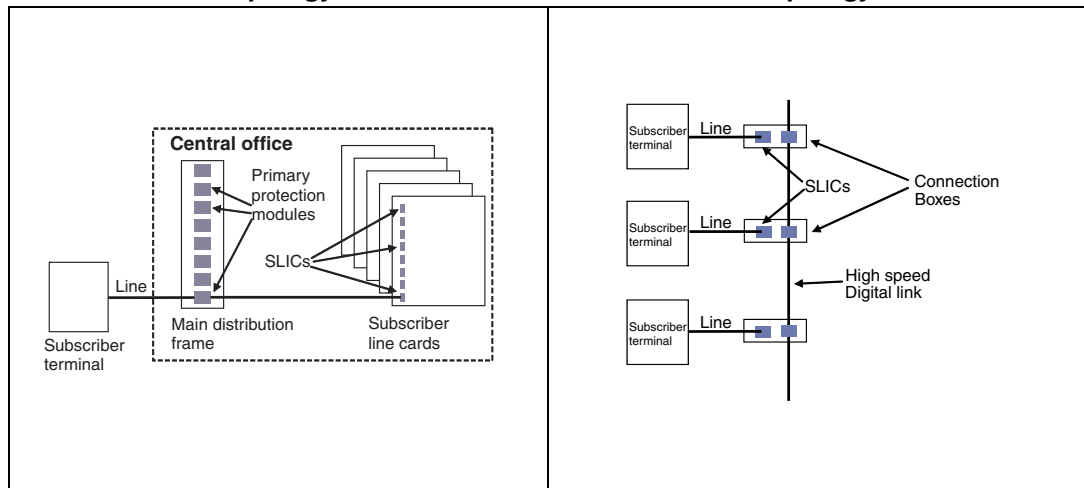

Figure 1 shows the classic analog telecom system topology, where subscriber terminals are linked to the central office (CO) by means of copper wires. Inside the CO, lines cross the main distribution frame (MDF) and then are connected to subscriber line cards. In subscriber line cards, lines are managed by subscriber line interface circuits (SLIC).

Figure 2 shows the new telecommunication system topology. In this case the long distance carrying of signals is through modern digital lines like optical fiber, coax, WLL, and others, while the local distribution is still using copper twisted pairs.

Despite the fact that in both cases the subscriber terminal is connected to the SLIC by means of copper wires, the line length is quite different (a few hundred meters to a few kilometers for the classic system and a few meters to a few tens of meters for the new system topology). This difference in length of the subscriber terminal connection makes the management of the signal amplitude and the SLIC different.

Contents

1	Telecom disturbances	3
2	LCP concept	5
3	LCP topology based protection family	7
4	Long line protection	8
5	Short line protection	14
6	Conclusion	15
7	Revision history	15

1 Telecom disturbances

Figure 3 shows both classic (1) and new (2) telecommunication lines when they are subjected to over voltages. These transients are mainly due to three kinds of disturbances. The first one is linked to atmospheric effects (lightning); the second one is produced by the 50/60 Hz mains network, while the third one is produced by electrostatic discharge (ESD). Today, simulations of these disturbances are well defined in worldwide or national standards.

Figure 3. Line disturbance location

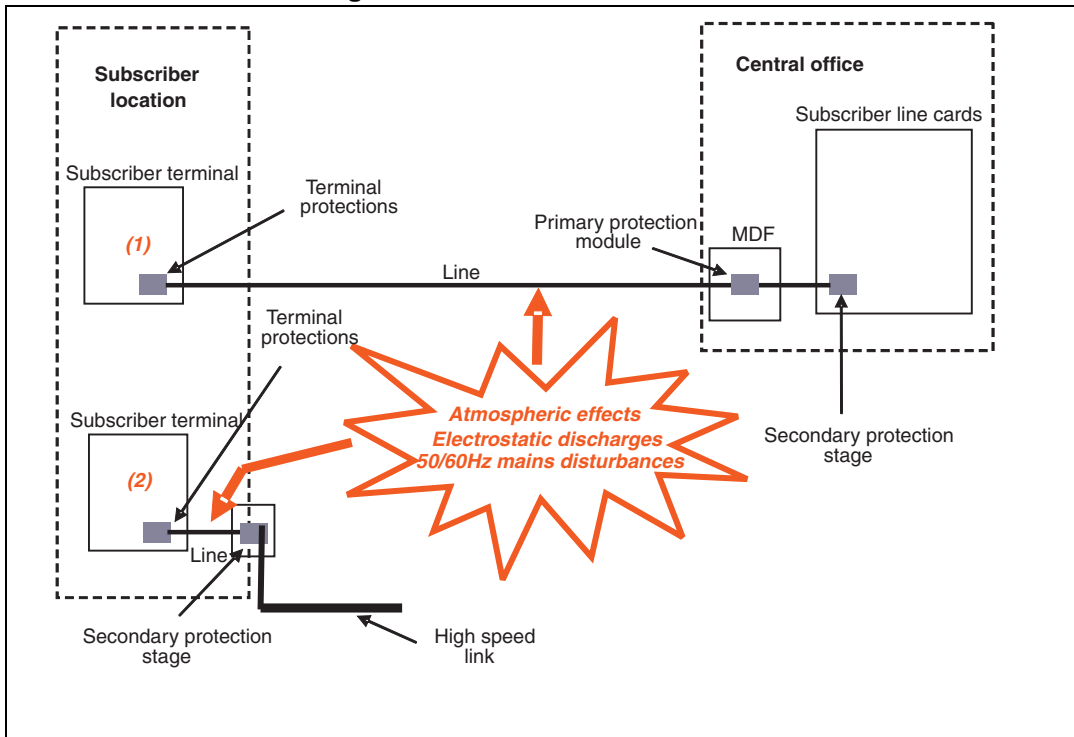

The standards used to qualify wired telecom equipment for European and Asian markets refer to the ITU-T Kxx requirements (International Telecommunication Union). These recommendations are based on the 10/700 μ s surge tests for lightning simulation while power induction and power crossing tests use 50 Hz alternating voltage from 230 to 600 V of a duration of between 0.2 s to 15 min.

Figure 4 shows an example circuit for lightning surge simulation. This simulation is defined by the ITU-T K20 standard. This simulation is based on the discharge of a 20 μ F capacitor through resistors. The 20 μ F capacitor and the 50 Ω resistor define the surge wave duration while the 15 Ω resistor and the 0.2 μ F capacitor manage its rise time (see Figure 4a). In this case the surge is defined as a 10/700 μ s voltage waveform.

Figure 4. ITU-T K20 lightning surge test definition

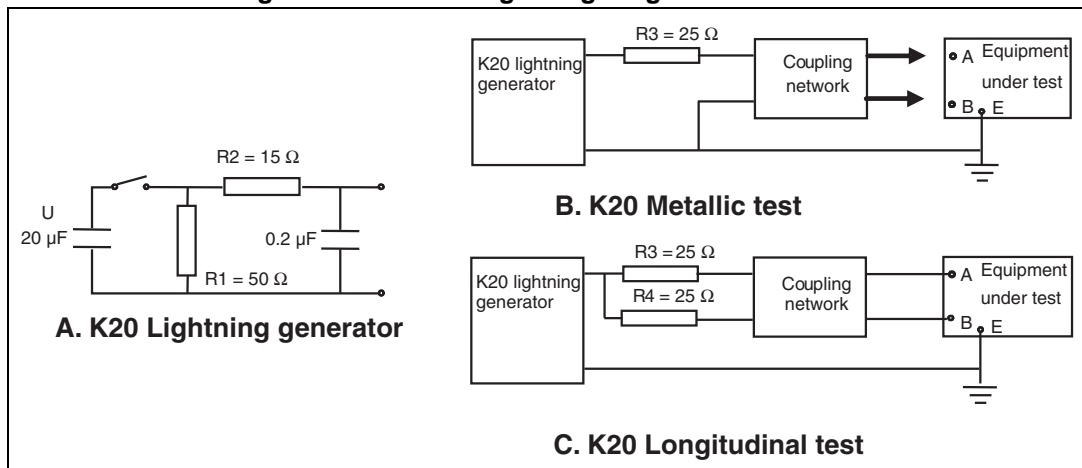

The applied peak voltage is 1.5 kV (10/700 μs - Enhanced level) which corresponds to an applied peak current of 37.5 A (5/310 μs). Five applications of each polarity have to be performed. These tests must be managed in both metallic and longitudinal modes (see [Figure 4b](#) and [Figure 4c](#)). The standard defines the acceptance criterion of these tests as A - “the equipment shall continue to operate properly after the test”.

[Figure 5](#) gives the ITU-T K20 requirements for both power induction and contact test circuits. This simulation is based on the application of 50/60 Hz through a resistor during a programmed duration (i.e. 0.2 s for induction and 15 min. for contact).

Figure 5. ITU-T K20 power induction and power contact surge test definition

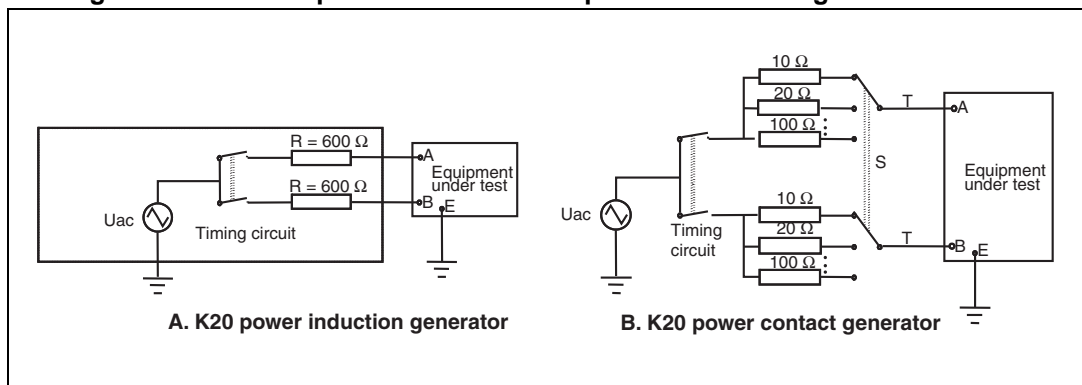

The applied rms voltage for the power induction test is 600 V which corresponds to an applied rms current of 1 A. The duration of the test is 0.2 s and five applications have to be performed. This test must be managed in both metallic and longitudinal modes. The standard defines the acceptance criterion as A - “the equipment shall continue to operate properly after the test”.

The applied rms voltage for the power contact tests is 230 V. The applied rms current depends on the resistor used (10, 20, 40, 80, 160, 300, 600 and 1000 Ω). The duration of the test is 15 min. and only one application has to be performed. This test must be managed in both metallic and longitudinal modes. The standard defines the acceptance criterion as A - “the equipment shall continue to operate properly after the test” for 160, 300 and 600 Ω (Enhanced level) and as B - “the equipment may be damaged but should not become a fire or electrical hazard”, for the other resistors.

Table 1. IEC61000-4-2 ESD surge standard

1a contact discharge		1b air discharge	
Level	Test voltage (kV)	Level	Test voltage (kV)
1	2	1	2
2	4	2	4
3	6	3	8
4	8	4	15
X ⁽¹⁾	Special	X ⁽¹⁾	Special

1. "X" is a level to be defined

Table 1 shows the most commonly used worldwide ESD standards. Generally, level 4 is required.

Section 2 presents the protection concept used for SLICs on both short and long line applications.

2 LCP concept

Figure 6. LCP152xx concept behavior

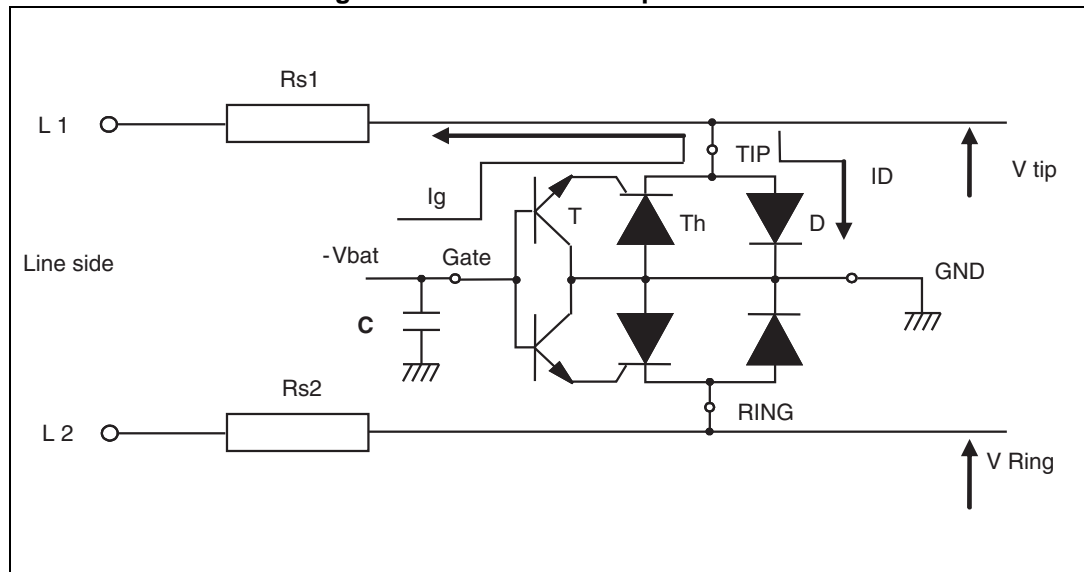

Figure 6 shows the classic protection circuit using the LCP152xx crowbar concept. This topology has been developed to protect the new high voltage SLICs. It allows the system to be programmed for the negative firing threshold while the positive clamping value is fixed at GND.

When a negative surge occurs on one wire (L1 for example), a current I_g flows through the base of the transistor T and then injects a current in the gate of the thyristor Th. Then Th turns on and the whole surge current shunts to ground (GND). After the surge, when the current flowing through Th becomes lower than the holding current value I_h , Th switches off.

When positive surges occur on one wire (L1 for example), the diode D conducts the surge current to ground.

The capacitor C is used to speed up the crowbar structure firing during the fast negative surge edges. This allows the dynamic breakover voltage at the SLIC TIP and RING inputs to be minimized during fast strikes. Please note that this capacitor is generally present around the SLIC $-V_{bat}$ pin. So to be efficient it has to be moved as close as possible to the LCP152xx Gate pin and to the reference ground track (or layer) (see [Figure 7](#)). The optimum value for C is 220 nF.

Figure 7. Example of PCB layout based on LCP1521S protection

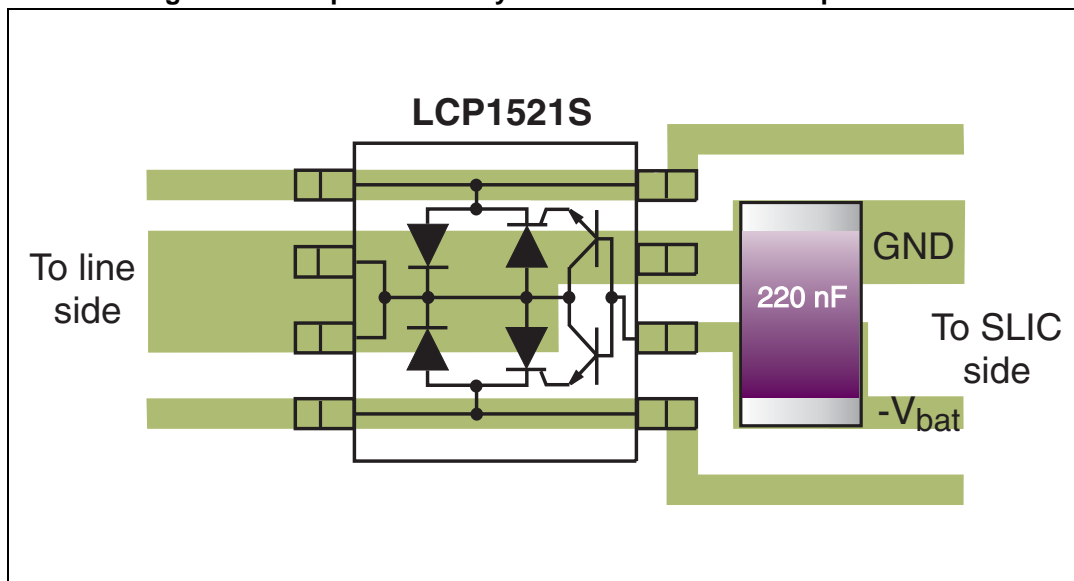

[Figure 7](#) shows the PCB layout that should be used for the LCP1521S which is in the SO-8 package. The LCP152xx is also available in QFN 3 x3 6-lead package, and is called LCP152DEE.

The series resistors R_{s1} and R_{s2} shown in [Figure 6](#) represent the fuse resistors or the PTC which are mandatory to withstand the power contact tests imposed by the different country standards.

Taking into account this fact the actual lightning surge current flowing through the LCP is equal to:

$$I_{surge} = V_{surge} / (R_g + R_s)$$

With

V_{surge} = peak surge voltage imposed by the standard.

R_g = series resistor of the surge generator

R_s = series resistor of the line card (e.g. PTC)

For example, for a line card with 10 Ω of series resistors which has to be qualified under ITU-T K20 (Enhanced level) surge, the actual current through the LCP152xx is equal to:

$$I_{surge} = 1500 / (40 + 10) = 30 \text{ A}$$

3 LCP topology based protection family

They are two kinds of protection product families based on the LCP concept:

The LCP152xx protects lines within the range from GND to $-V_{bat}$. The electrical characteristic, given in [Figure 8](#), shows the asymmetrical behavior of this protection function. The V_{gate} threshold voltage is controlled by the negative bias voltage applied on the gate pin. This voltage can be within the range from 0 to -150 V for the LCP152xx.

Figure 8. LCP152xx circuit and electrical characteristic

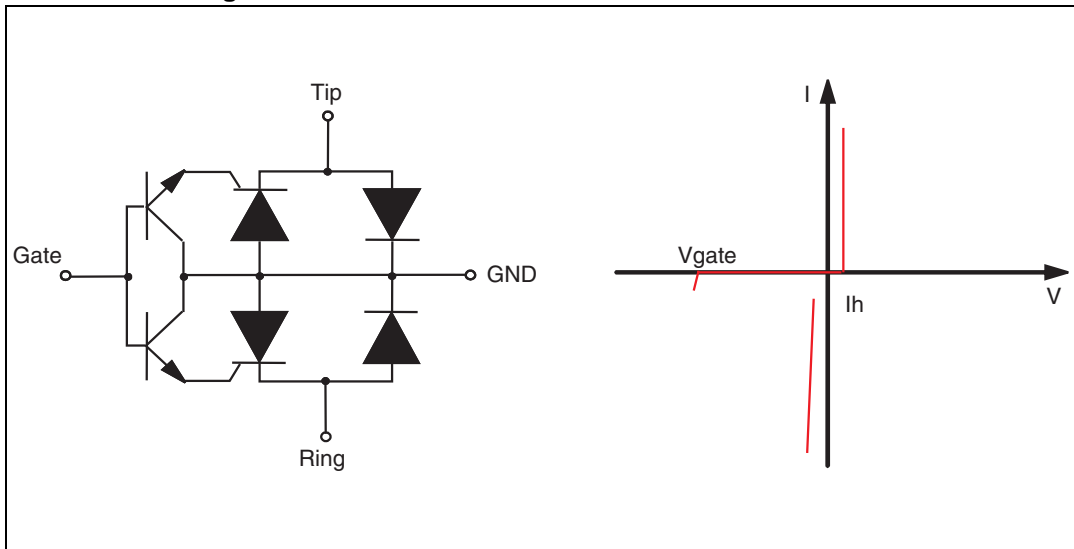

The LCP02-150xx is designed to protect lines where the normal operating voltage can be negative or positive, and located between $-V_{bat}$ and $+V_b$. The electrical characteristic, given in [Figure 9](#), shows a crowbar adjustable function for both positive and negative areas of the curve. The knee of the positive part of the curve is controlled by the G_p gate bias while the knee of the negative part is controlled by the G_n gate bias.

Figure 9. LCP02-150xx circuit and electrical characteristic

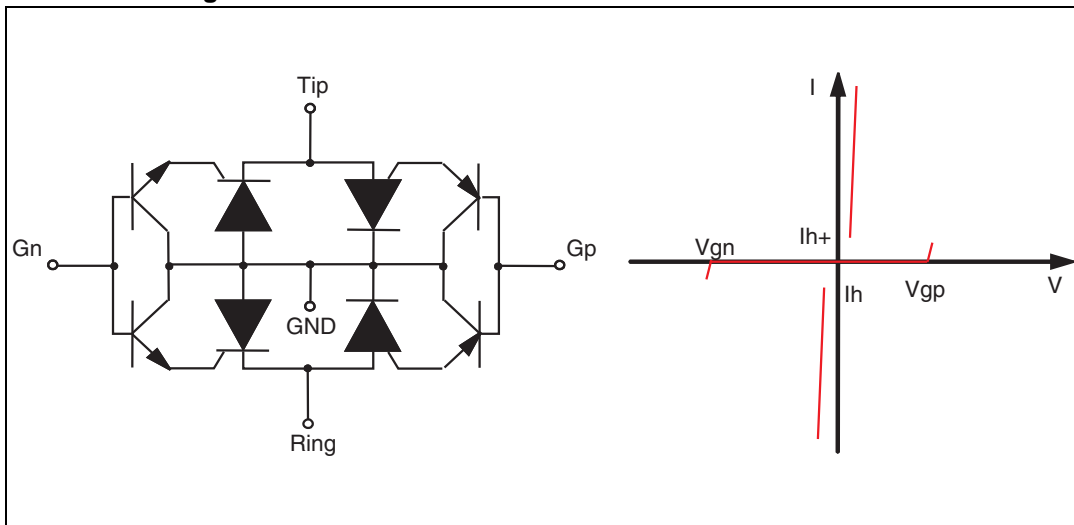

4 Long line protection

The long line concept is used for classic wired telecom networks. With this topology, the core of the system is a huge central office from where many lines connect the subscribers. In this case the line length can reach several kilometers. This type of subscriber line card, based on silicon integrated SLIC, can be classified within two families. The older one uses mechanical relays to manage ring generation, speech mode and tests. The second is based on SLIC with integrated ring generator.

Figure 10. SLIC with external ring signal management

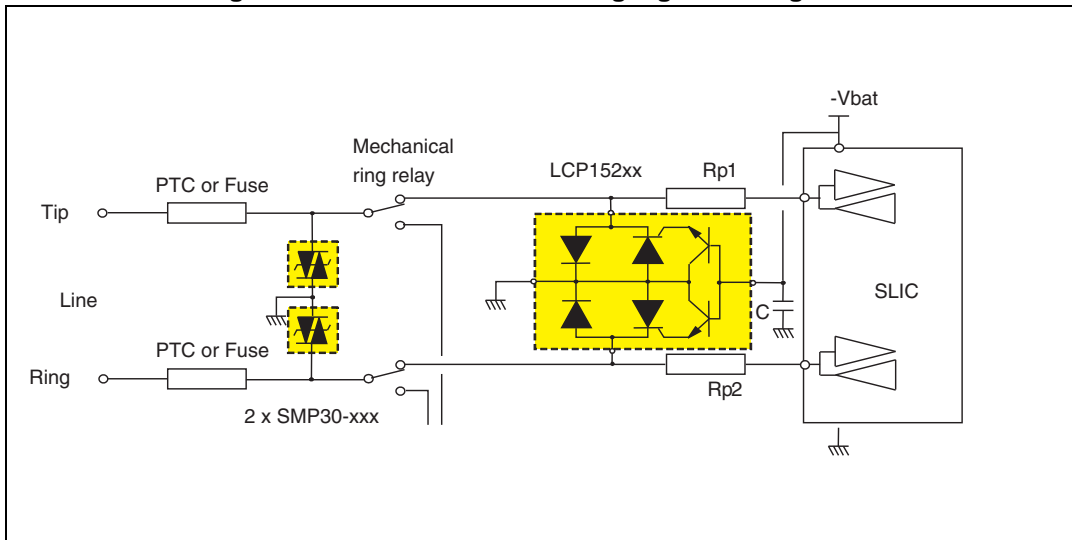

Figure 10 shows the protection circuit of a SLIC with mechanical ring relay. The protection function is split in two stages; one is located between the line and the ring relay while the other is located between the ring relay and the SLIC.

The first stage, dedicated to the ring generator protection, is provided by two SMP surge suppressors (Trisil™ - SMP30-xxx to be compliant with ITU-T K20 standard to be considered for equipment located in Central Offices in Europe and Asia). This stage acts symmetrically at $\pm V$ (often ± 200 V for Europe and Asia) where V is chosen slightly higher than the maximum ring voltage trip.

The goal of the second stage is to manage a fine protection level in phase with the requirements of the modern, high-integration technology SLIC. This stage must switch on for a voltage higher than the supply voltage of the SLIC.

The resistors R_{px} are not mandatory but have to be added when the SLIC to be protected is very sensitive to the latch-up phenomena. The recommended value is then 20 or 30 Ω .

TM: Trisil is a trademark of STMicroelectronics

Figure 11. LCP1521S behavior during -1.5 kV, 10/700 μs metallic (on TIP) surge

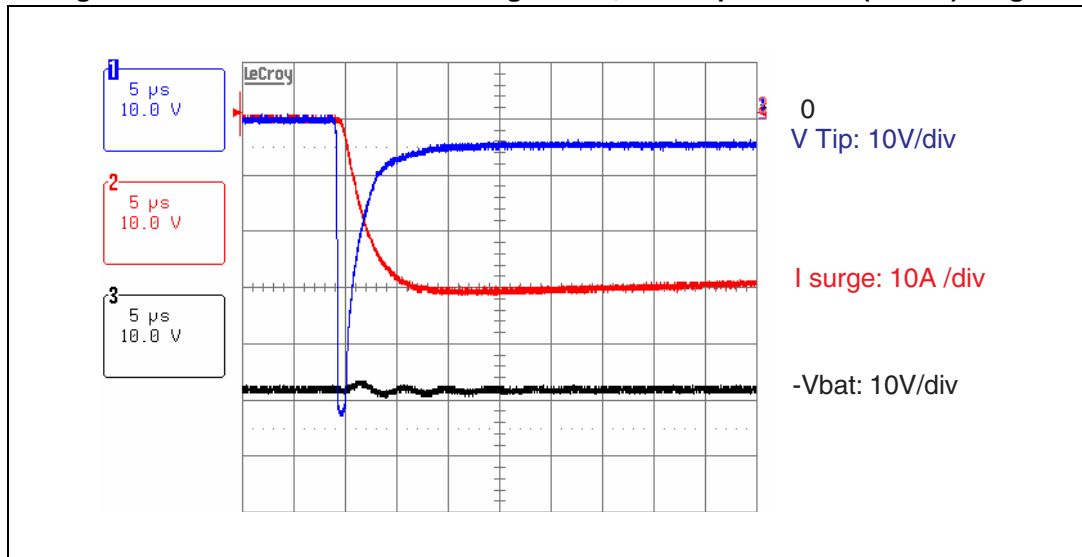
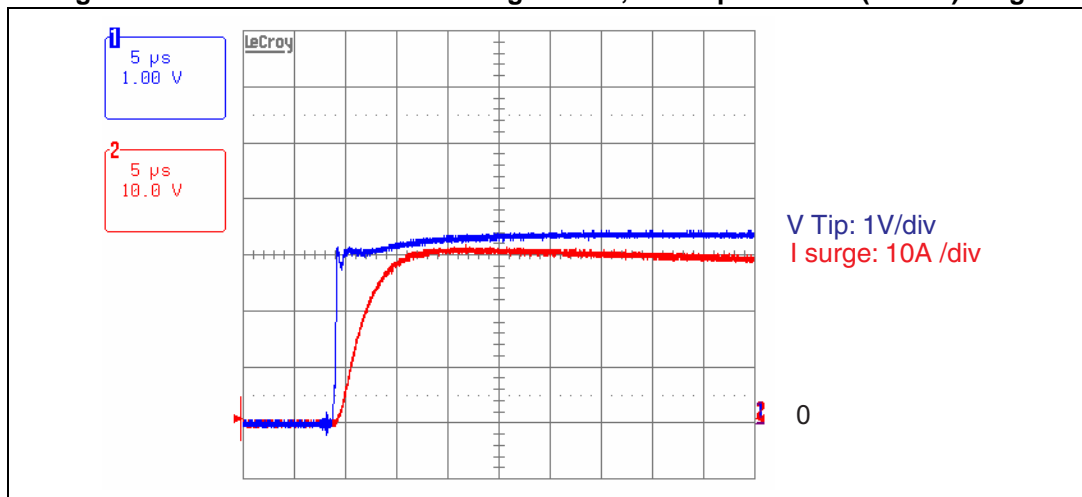

Figure 11 shows the surge current through the TIP pin of LCP1521S and the voltage across it when subjected to -1.5 kV 10/700 μs metallic (on TIP) surge, the gate voltage ($-V_{bat}$) is also monitored.

A PTC of 15 Ω has been chosen to protect the LCP1521S and then the SLIC from K20 power contact tests. Hence, the surge current is equal to $-1500 / (40+15) = -27.3$ A. The TIP voltage falls a bit lower than the battery voltage (often -48 V for Europe and Asia) and then fires.

The LCP1521S and the PTC still continue to operate properly after the test in accordance with the K20 A criterion.

Figure 12. LCP1521S behavior during +1.5 kV, 10/700μs metallic (on TIP) surge



During a positive surge on the TIP wire, the diode between TIP and GND conducts and then all the surge current flows to ground. This behavior is shown in Figure 12.

The LCP1521S and the PTC still continue to operate properly after the test in accordance with the K20 A criterion.

Figure 13. LCP1521S behavior during 600 V_{rms}, 600 Ω, 0.2 s metallic (on TIP) power induction test

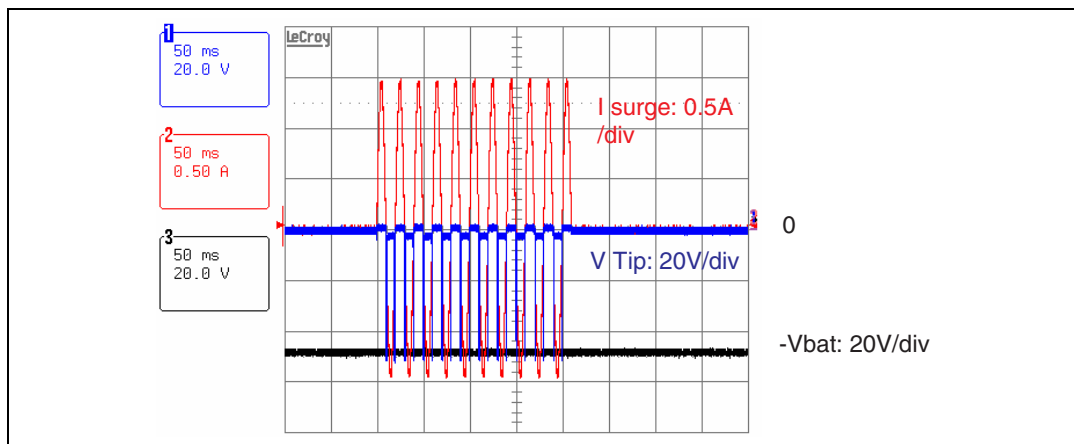
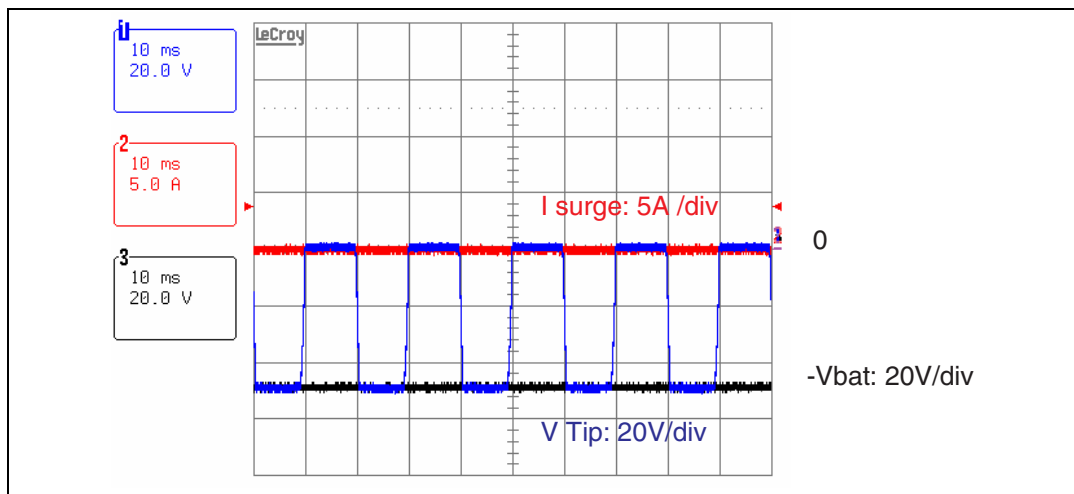

Figure 13 shows the voltage across the TIP pin of LCP1521S and current through it when subjected to a 600 V_{rms}, 600 Ω, 0.2 s ITU-T K20 power induction test, the gate voltage (-V_{bat}) is also monitored. The voltage trip at the TIP pin is between +1 V and the battery voltage (-48 V).

The LCP1521S and the PTC still continue to operate properly after the test in accordance with the K20 A criterion.

Figure 14. LCP1521S behavior during 230 V_{rms}, 10 Ω, 15 min. metallic (on TIP) power contact test



For power contact tests, except the one with 1000 Ω resistor, the PTC heats up and then its resistor value increases drastically, which gives a very low gate current that becomes lower than the gate triggering current of the LCP1521S: hence, from this moment, the LCP1521S doesn't fire anymore, but it only clamps. Figure 14 shows the voltage across the TIP pin of LCP1521S and current through it when subjected to a 230 V_{rms}, 10 Ω, 15 min. ITU-T K20 power contact test, the gate voltage (-V_{bat}) is also monitored. The voltage trip at the TIP pin is between +1 V and the battery voltage (-48 V).

The LCP1521S and the PTC still continue to operate properly after the test in accordance with the K20 A criterion, while this test, with 10 Ω, requires only the K20 B criterion.

Figure 15. SLIC with internal ring signal management

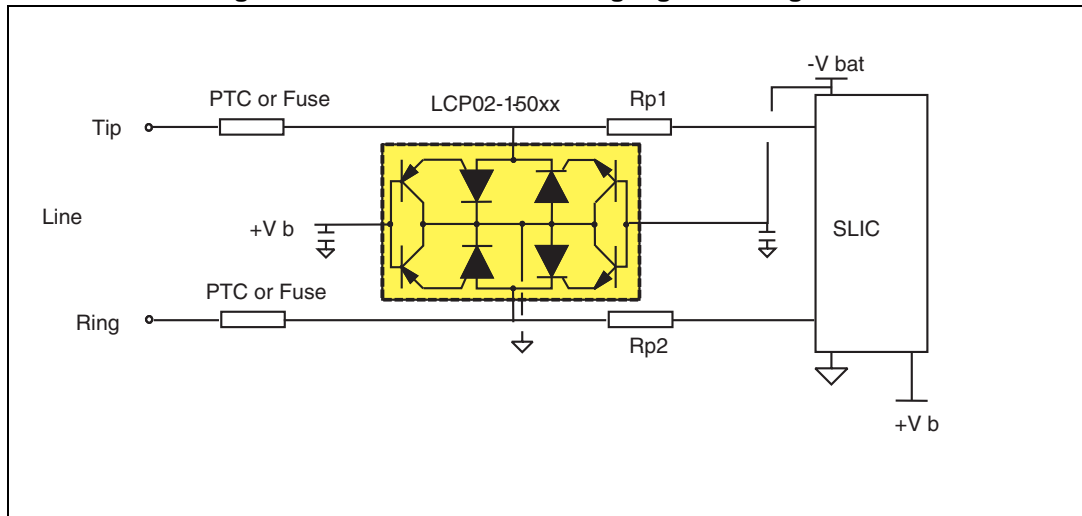

In [Figure 15](#) the SLIC is supplied by two battery voltages, one positive +V_b and one negative -V_{bat}. This allows the output pins to manage signals within this voltage range and to operate in DC biased ring signal mode. For this topology only one protection stage is needed to provide a fine action when transients reach the +V_b or -V_{bat} limit.

The LCP02-150xx exists in two versions: 30 A (10/1000 μs) for European and Asian markets, called LCP02-150B1; and 100 A (10/1000 μs) for the US market, called LCP02-150M.

Figure 16. LCP02-150B1 behavior during -1.5 kV, 10/700 μs metallic (on TIP) surge

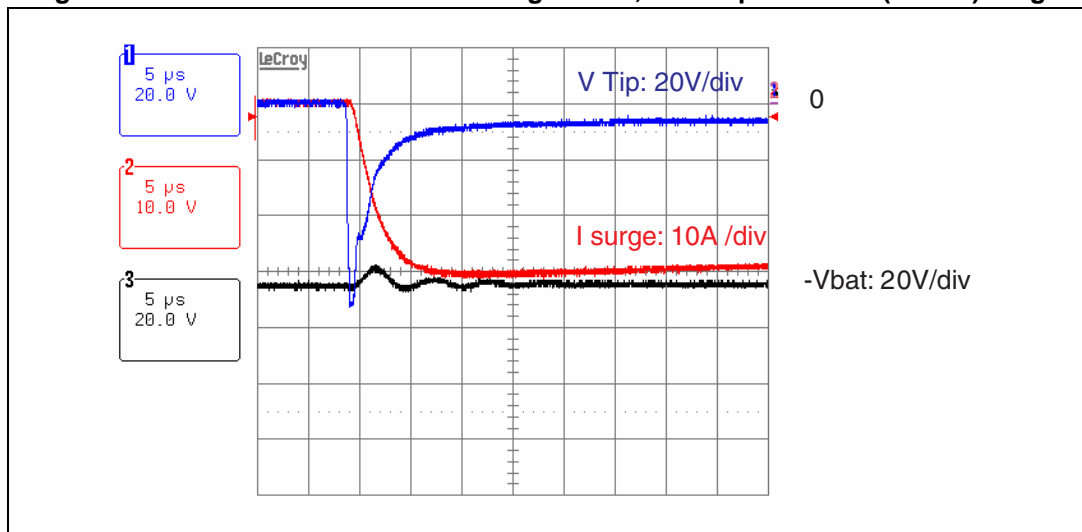

Figure 17. LCP02-150B1 behavior during +1.5 kV, 10/700 μs metallic (on TIP) surge

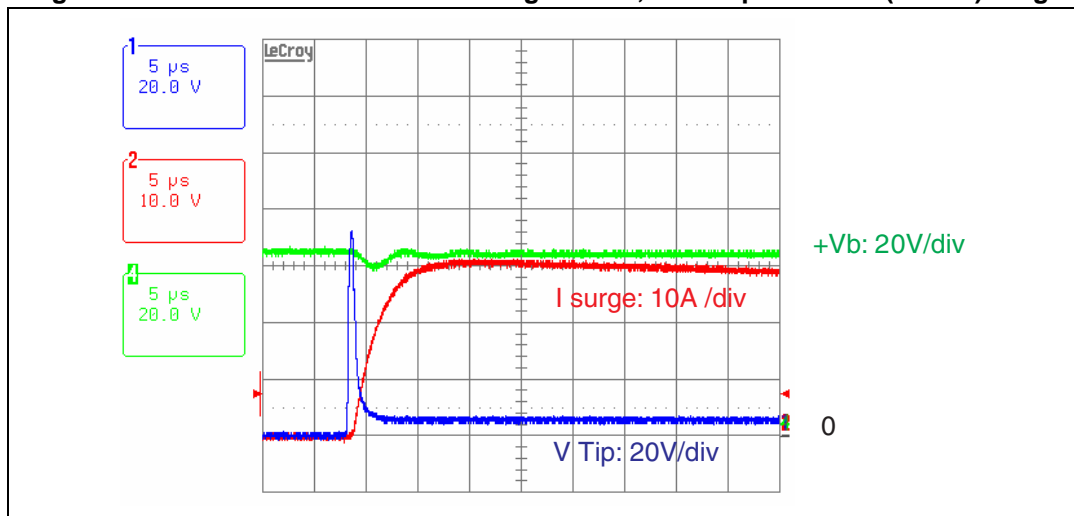

Figure 16 and Figure 17 show the surge current through the TIP pin of LCP02-150B1 and the voltage across it when subjected to - (Figure 16) then + (Figure 17) 1.5 kV, 10/700 μs metallic (on TIP) surge, and the gate voltages.

A PTC of 15 Ω has been chosen to protect the LCP02-150B1 and then the SLIC from K20 power contact tests. Hence, the surge current is equal to $1500 / (40+15) = 27.3$ A.

For these measurements, the positive gate G_p and the negative one G_n are connected to a 220 nF speed-up capacitor and are respectively biased at + and - 65 V. In such a condition, the maximum remaining voltages during the firing phase are about ± 75 V.

The LCP02-150B1 and the PTC still continue to operate properly after both tests in accordance with the K20 A criterion.

Figure 18. LCP02-150B1 behavior during 600 V_{rms}, 600 Ω, 0.2 s metallic (on TIP) power induction

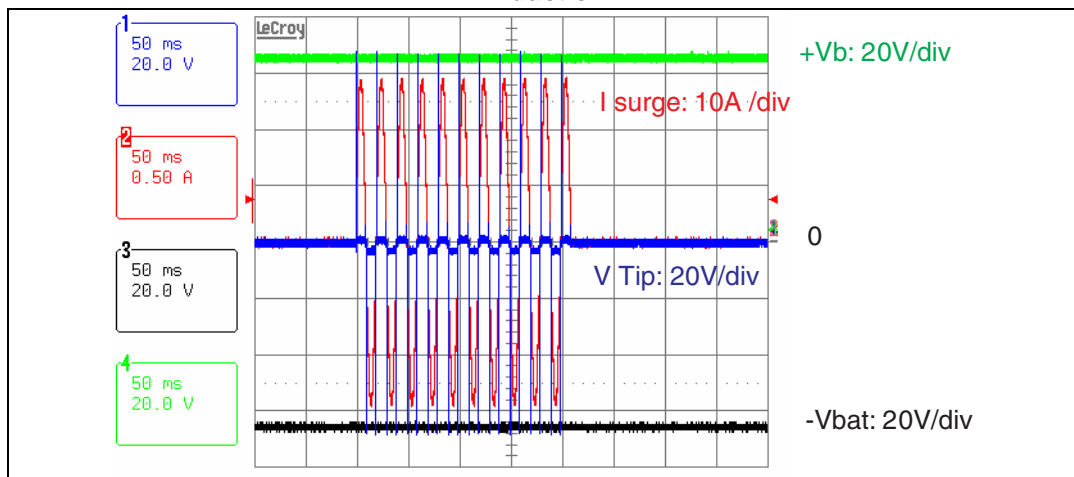

Figure 18 shows the voltage across the TIP pin of LCP02-150B1 and current through it when subjected to a 600 V_{rms}, 600 Ω, 0.2 s ITU-T K20 power induction test, and the gate voltages. The maximum remaining voltage is about equal to the G_p and G_n gate bias voltages ± 65 V.

The LCP02-150B1 and the PTC still continue to operate properly after the test in accordance with the K20 A criterion.

Figure 19. LCP02-150B1 behavior during 230 V_{rms}, 10 Ω, 15 min. metallic (on TIP) power contact

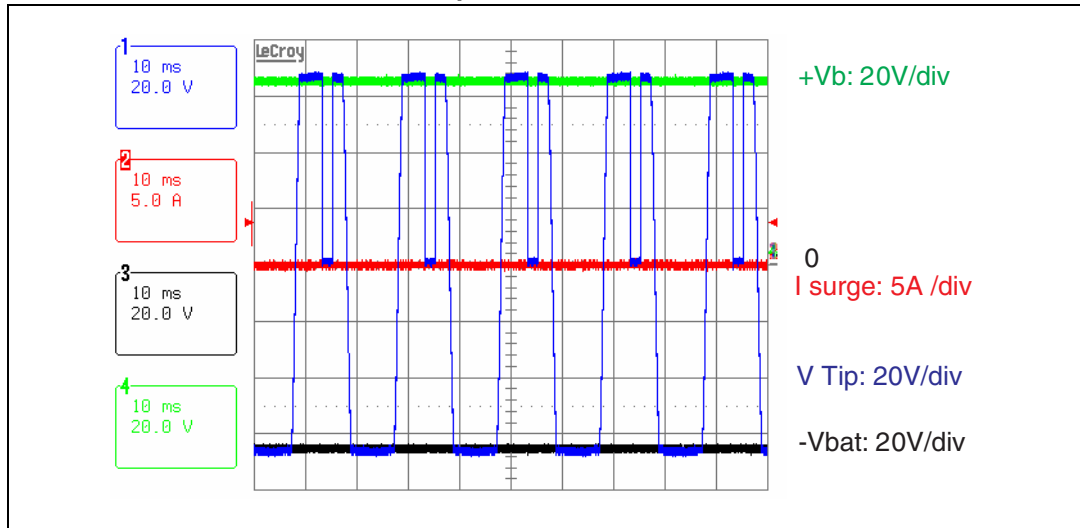

Figure 19 shows the voltage across the TIP pin of LCP02-150B1, the gate voltages and current through the LCP02-150B1 when subjected to 230 V_{rms}, through 10 Ω, for 15 min. - ITU-T K20 power contact test. For power contact tests, the PTC heats up and the LCP02-150B1 behaves like the LCP1521S in the negative domain. That is, from the moment that the negative gate current becomes lower than the negative gate triggering current of the LCP02-150B1, this device does not fire anymore, but only clamps. It still fires in the positive domain because its positive gate is highly sensitive. The voltage trip at the TIP pin is between both battery voltages ±65 V.

The LCP02-150B1 and the PTC still continue to operate properly after the test in accordance with K20 A criterion, while this test with 10 Ω requires only the K20 B criterion.

5 Short line protection

The short line concept is used for new telecom networks. This kind of line is linked to the new applications like WLL, fiber on the corner, NT1+, phone other cable TV network, PON, telecom by 50/60 Hz supply network, and others. The need for battery voltage as well as ringing voltage is lower than those for long line applications. This allows the use of a new generation of high voltage SLIC circuit which can be either single or double voltage.

Figure 20. Short line application using high voltage SLIC

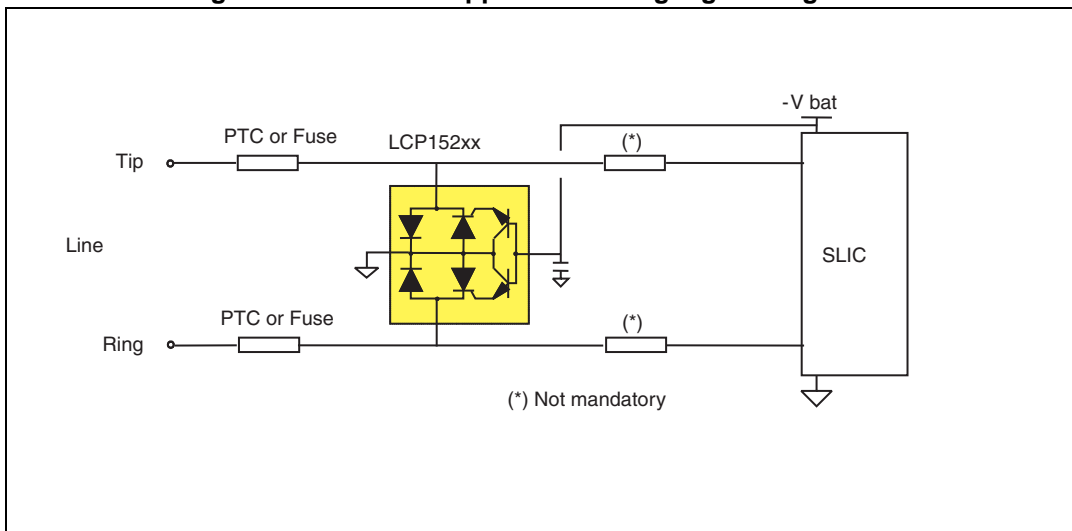
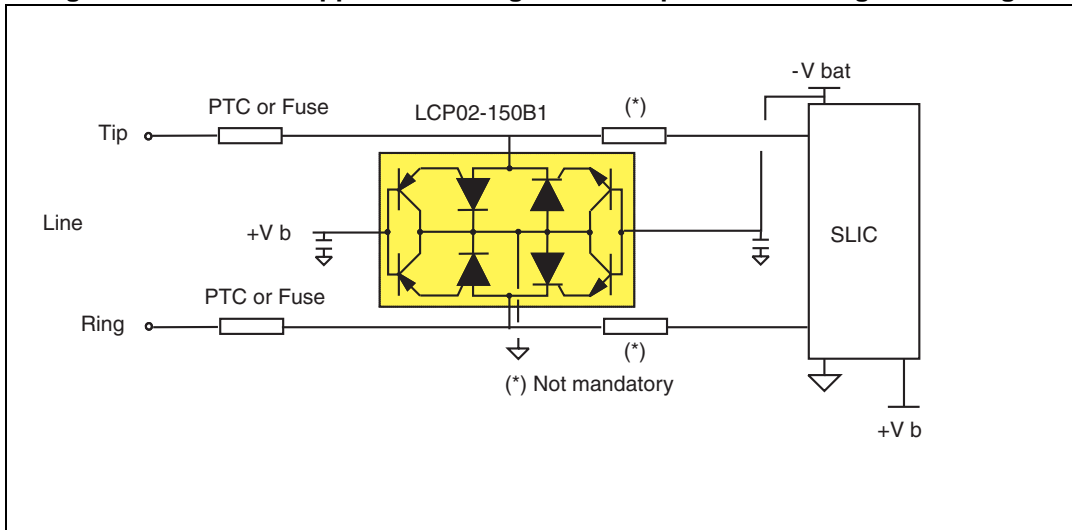

Figure 21. Short line application using SLIC with positive and negative voltages



6 Conclusion

The telecom deregulation everywhere in the world generated two kinds of line protection needs. The long line solutions are dedicated to the classic telecommunication networks while the short line solutions are linked to emerging remote applications. These quite new systems are based on optic fiber, WLL, phone over TV network or over 50/60 Hz supply network. For both long and short line applications, the protection is one of the major issues. STMicroelectronics is the major player in the telecom protection field for both wired and wireless equipment. As far as the analog telecom lines are concerned, the LCP concept is well adapted to protect SLICs. The LCP families cover the protection of all the SLICs of European and Asian markets.

7 Revision history

Table 2. Document revision history

Date	Revision	Changes
21-Nov-2005	1	First issue
25-Mar-2014	2	Updated trademark statement.

Please Read Carefully:

Information in this document is provided solely in connection with ST products. STMicroelectronics NV and its subsidiaries ("ST") reserve the right to make changes, corrections, modifications or improvements, to this document, and the products and services described herein at any time, without notice.

All ST products are sold pursuant to ST's terms and conditions of sale.

Purchasers are solely responsible for the choice, selection and use of the ST products and services described herein, and ST assumes no liability whatsoever relating to the choice, selection or use of the ST products and services described herein.

No license, express or implied, by estoppel or otherwise, to any intellectual property rights is granted under this document. If any part of this document refers to any third party products or services it shall not be deemed a license grant by ST for the use of such third party products or services, or any intellectual property contained therein or considered as a warranty covering the use in any manner whatsoever of such third party products or services or any intellectual property contained therein.

UNLESS OTHERWISE SET FORTH IN ST'S TERMS AND CONDITIONS OF SALE ST DISCLAIMS ANY EXPRESS OR IMPLIED WARRANTY WITH RESPECT TO THE USE AND/OR SALE OF ST PRODUCTS INCLUDING WITHOUT LIMITATION IMPLIED WARRANTIES OF MERCHANTABILITY, FITNESS FOR A PARTICULAR PURPOSE (AND THEIR EQUIVALENTS UNDER THE LAWS OF ANY JURISDICTION), OR INFRINGEMENT OF ANY PATENT, COPYRIGHT OR OTHER INTELLECTUAL PROPERTY RIGHT.

ST PRODUCTS ARE NOT DESIGNED OR AUTHORIZED FOR USE IN: (A) SAFETY CRITICAL APPLICATIONS SUCH AS LIFE SUPPORTING, ACTIVE IMPLANTED DEVICES OR SYSTEMS WITH PRODUCT FUNCTIONAL SAFETY REQUIREMENTS; (B) AERONAUTIC APPLICATIONS; (C) AUTOMOTIVE APPLICATIONS OR ENVIRONMENTS, AND/OR (D) AEROSPACE APPLICATIONS OR ENVIRONMENTS. WHERE ST PRODUCTS ARE NOT DESIGNED FOR SUCH USE, THE PURCHASER SHALL USE PRODUCTS AT PURCHASER'S SOLE RISK, EVEN IF ST HAS BEEN INFORMED IN WRITING OF SUCH USAGE, UNLESS A PRODUCT IS EXPRESSLY DESIGNATED BY ST AS BEING INTENDED FOR "AUTOMOTIVE, AUTOMOTIVE SAFETY OR MEDICAL" INDUSTRY DOMAINS ACCORDING TO ST PRODUCT DESIGN SPECIFICATIONS. PRODUCTS FORMALLY ESCC, QML OR JAN QUALIFIED ARE DEEMED SUITABLE FOR USE IN AEROSPACE BY THE CORRESPONDING GOVERNMENTAL AGENCY.

Resale of ST products with provisions different from the statements and/or technical features set forth in this document shall immediately void any warranty granted by ST for the ST product or service described herein and shall not create or extend in any manner whatsoever, any liability of ST.

ST and the ST logo are trademarks or registered trademarks of ST in various countries.

Information in this document supersedes and replaces all information previously supplied.

The ST logo is a registered trademark of STMicroelectronics. All other names are the property of their respective owners.

© 2014 STMicroelectronics - All rights reserved

STMicroelectronics group of companies

Australia - Belgium - Brazil - Canada - China - Czech Republic - Finland - France - Germany - Hong Kong - India - Israel - Italy - Japan - Malaysia - Malta - Morocco - Philippines - Singapore - Spain - Sweden - Switzerland - United Kingdom - United States of America

www.st.com