

### 800mA standalone linear Li-Ion battery charger with thermal regulation

#### Introduction

One way to minimize the size and complexity of a battery charger is to use a linear-type charger. The linear charger drops the AC adapter voltage down to the battery voltage. The number of external components is low: linear chargers require input and output bypass capacitors, and sometimes need an external pass transistor, and resistors for setting voltage and current limits.

The main pitfall of a linear charger is power dissipation. The charger simply drops the AC adapter voltage down to the battery voltage.

In the case of an 800mA charger, a  $5V \pm 10\%$  regulated AC adapter voltage, and battery voltage that varies between 4.2V and 2.5V, the power dissipation can range from 0.6W to 2.0W.

This type of charger is simpler than the switch-mode type, mainly because the passive LC filter is not required. It dissipates the most power when the battery voltage is at its minimum, since the difference between the fixed input voltage and the battery voltage is greatest during this condition.

#### Application diagram



---

# Contents

<b>1</b>	<b>STBC08 description</b> .....	<b>3</b>
<b>2</b>	<b>Stability considerations</b> .....	<b>4</b>
<b>3</b>	<b>Board layout considerations</b> .....	<b>5</b>
<b>4</b>	<b>External components</b> .....	<b>6</b>
<b>5</b>	<b>Power dissipation</b> .....	<b>7</b>
<b>6</b>	<b>Automatic recharge</b> .....	<b>8</b>
<b>7</b>	<b>CHRG and Power-on status output pins</b> .....	<b>9</b>
<b>8</b>	<b>USB and wall adapter power</b> .....	<b>10</b>
<b>9</b>	<b>Charge current</b> .....	<b>11</b>
	9.1 Programming charge current .....	11
	9.2 Maximum charge current in temperature .....	11
	<b>Appendix A Board layout</b> .....	<b>12</b>
	<b>Revision history</b> .....	<b>13</b>

# 1 STBC08 description

The STBC08 is a constant current/constant voltage charger for single cell Li-Ion battery. No external sense resistor or blocking diode is required and its MLPD 3x3mm<sup>2</sup> 6L package make it ideally suited for portable applications.

The STBC08 is designed to comply with USB power specifications. An internal block regulates the current when the junction temperature increases in order to protect the device when it operates in high power or high ambient temperature.

The maximum power dissipation occurs when  $V_{BAT}$  is 2.9V with the maximum charge current.

The charge voltage is fixed at 4.2V, and the charge current limitation can be programmed using a single resistor connected between pins PROG and GND. The charge cycle finishes when the current flowing to the battery is 1/10 of the programmed value. If the external adaptor is removed, the STBC08 switches off and only 2 $\mu$ A can flow from the battery to the device. The device can be put into Shutdown Mode, reducing the supply current to 25 $\mu$ A.

**Figure 1. Block diagram**

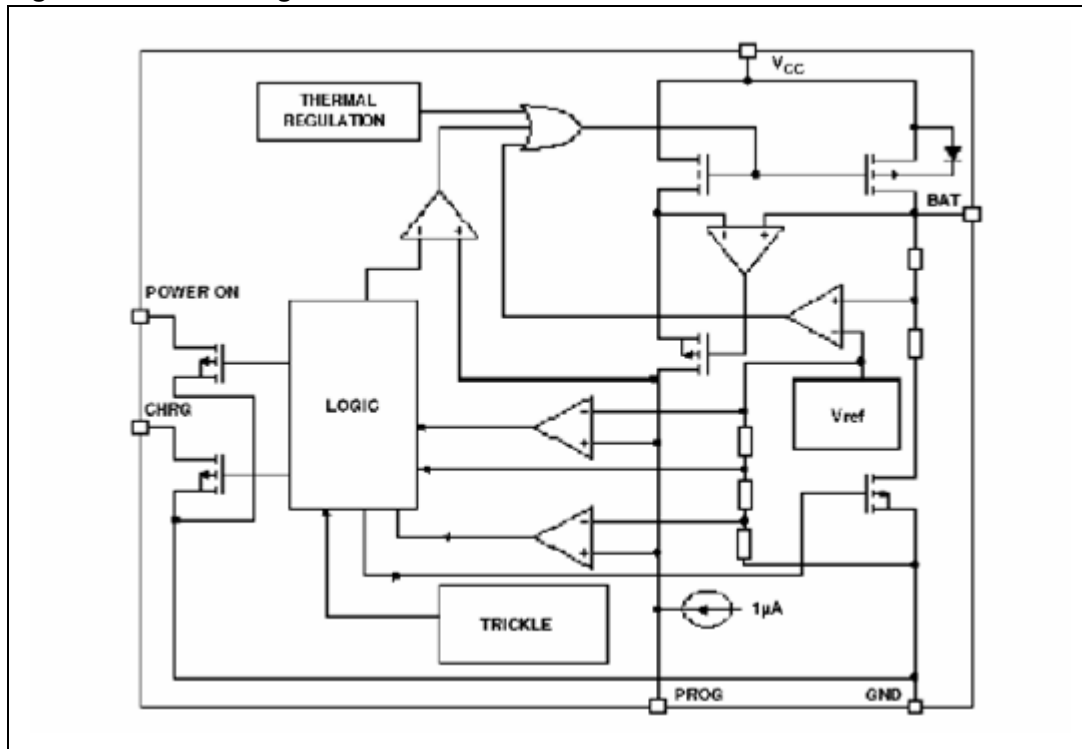

## 2 Stability considerations

The STBC08 contains two control loops: constant voltage and constant current. The constant-voltage loop is stable without any compensation when a battery is connected with low impedance leads. Excessive lead length, however, may add enough series inductance to require a bypass capacitor of at least 1µF from BAT to GND. Furthermore, a 4.7µF capacitor with a 0.2Ω to 1Ω series resistor from BAT to GND is required to keep ripple voltage low when the battery is removed.

High value capacitors with very low ESR (especially ceramic) reduce the constant-voltage loop phase margin.

Ceramic capacitors up to 22µF may be used in parallel with a battery, but larger ceramics should be decoupled with 0.2Ω to 1Ω of series resistance.

In constant-current mode, the PROG pin is in the feedback loop, not the battery. Because of the additional pole created by PROG pin capacitance, capacitance on this pin must be kept to a minimum. With no additional capacitance on the PROG pin, the charger is stable with program resistor values as high as 12k. However, additional capacitance on this node reduces the maximum allowed program resistor. Therefore, if the PROG pin is loaded with a capacitance, C<sub>PROG</sub>, the following equation should be used to calculate the maximum resistance value for R<sub>PROG</sub>:

### Equation 1

$$R_{PROG} \leq \frac{1}{2\pi \cdot 5 \cdot 10^5 \cdot C_{PROG}}$$

Average, rather than instantaneous, battery current may be of interest to the user. For example, if a switching power supply operating in low current mode is connected in parallel with the battery, the average current being pulled out of the BAT pin is typically of more interest than the instantaneous current pulses. In such a case, a simple RC filter can be used on the PROG pin to measure the average battery current as shown in [Figure 2](#).

This design includes a 20kΩ resistor between the PROG pin and the filter capacitor to ensure stability (C<sub>FILTER</sub> = 100nF).

**Figure 2. Isolating capacitive load on PROG pin and filtering**

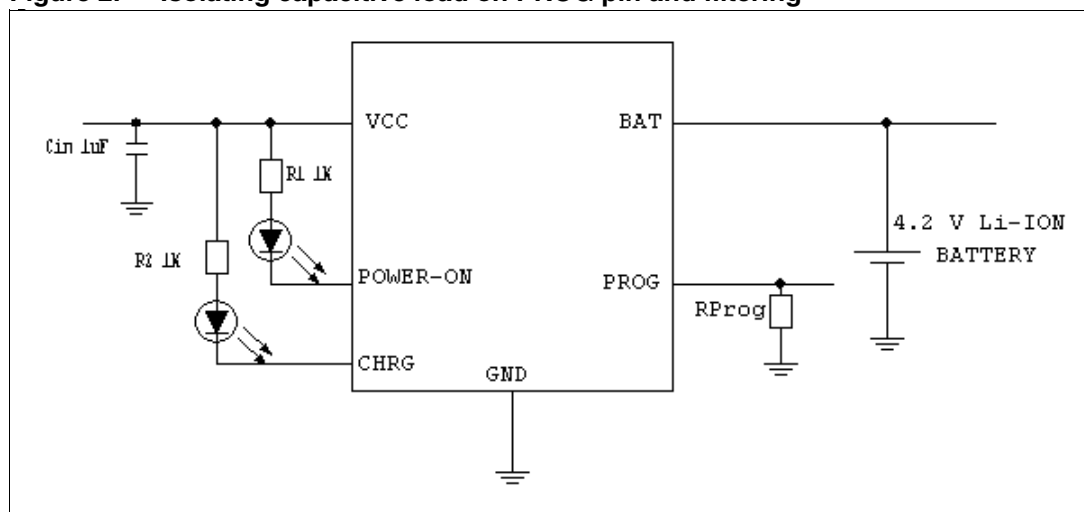

### 3 Board layout considerations

Due to the small size of the MLP package, it is very important to use a good thermal PC board layout to maximize the available charge current. The thermal path for the heat generated by the IC is from the die to the copper lead frame, through the package leads, (especially the ground lead) to the PC board copper. The PC board copper is the heat sink. The footprint copper pads should be as wide as possible and expand out to larger copper areas to spread and dissipate the heat to the surrounding ambient. Feed-through vias to inner or backside copper layers are also useful in improving the overall thermal performance of the charger. Other heat sources on the board, not related to the charger, must also be considered when designing a PC board layout because they will affect overall temperature rise and the maximum charge current.

[Table 1](#) lists thermal resistance for several different board sizes and copper areas.

**Table 1. Measured thermal resistance (2-layer board)**

Copper area		Board area	Thermal resistance junction-to-ambient
Top	Bottom		
2500mm <sup>2</sup>	2500mm <sup>2</sup>	2500mm <sup>2</sup>	125°C/W
1000mm <sup>2</sup>	2500mm <sup>2</sup>	2500mm <sup>2</sup>	125°C/W
225mm <sup>2</sup>	2500mm <sup>2</sup>	2500mm <sup>2</sup>	130°C/W
100mm <sup>2</sup>	2500mm <sup>2</sup>	2500mm <sup>2</sup>	135°C/W
50mm <sup>2</sup>	2500mm <sup>2</sup>	2500mm <sup>2</sup>	150°C/W

[Appendix A: Board layout on page 12](#) contains an illustration of the complete assembly board.

## 4 External components

This application requires few external components: two ceramic capacitors ( $C_{IN} = 1\mu\text{F}$ ,  $C_{OUT} = 4.7\mu\text{F}$ ) and one resistor ( $R_{PROG}$ ).

For input and output capacitors, ST recommends using ceramic capacitors with low ESR. For good stability of device supplied from low input voltage 2.6V at maximum ratings of output, ST recommends using  $1\mu\text{F}/6.3\text{V}$  as a minimum value for the input capacitor and  $4.7\mu\text{F}/6.3\text{V}$  as a minimum value for the output capacitor.

**Table 2. Bill of materials**

Symbol	Parameter	Type	Qty	Supplier	Value	Unit
Cin	Input Cap.	Ceramic Low ESR GRM155F50J105ZE01	1	Murata	1	$\mu\text{F}$
Cbat	Output Cap.	Ceramic Low ESR GRM188r60J475ke19	1	Murata	4.7	$\mu\text{F}$
Rusb	Usb Current Set	Thick film type 1% CRG0603J2K0	1	THCO	2	KOhm
Rdc	DC Current Set	Thick film type 1% CRG0603J10K0	1	THCO	10	KOhm
N-Pmos	Nmos-Pmos IC	STS7C4F30	1	ST		
D1	SCHOTTKY	STPS1L40M	1	ST		
Rled	Limit Led Current	Thick film type 1% CRG0603J1K0	2	THCO	1	KOhm
Rpull	Pull down resistor	Thick film type 1% CRG0603J1K0	1	THCO	1	KOhm
Rf	Resistance Filter	Thick film type 1% CRG0603J20K0	1	THCO	20	KOhm
Cf	Capacitor Filter	Ceramic Low ESR GRM188r71e104ka01	1	Murata	100	nF
Led Power	Led	1.8mm-RED LED L-2060ID	1	KINGBRIGHT		
Led Charge	Led	1.8mm-GREEN LED L-2060GD	1	KINGBRIGHT		
USB In	Connector USB	Mini B 54819-0572	1	Molex		

## 5 Power dissipation

The conditions that cause the STBC08 to reduce charge current through thermal feedback can be approximated by considering the power dissipated in the IC. For high charge currents, the STBC08 power dissipation is approximately:

### Equation 2

$$P_D = (V_{CC} - V_{BAT}) \cdot I_{BAT}$$

where  $P_D$  is the power dissipated,  $V_{CC}$  is the input supply voltage,  $V_{BAT}$  is the battery voltage and  $I_{BAT}$  is the current charge current. It is not necessary to perform any worst-case power dissipation scenarios because the STBC08 will automatically reduce the charge current to maintain the die temperature at approximately 120° C.

However, the approximate ambient temperature at which the thermal feedback begins to protect the IC is:

### Equation 3

$$T_A = 120^\circ \text{C} - P_D \theta_{JA}$$

### Equation 4

$$T_A = 120^\circ \text{C} - (V_{CC} - V_{BAT}) \cdot I_{BAT} \theta_{JA}$$

Example: Consider an STBC08 operating from a 5V wall adapter providing 400mA to a 3.7V Li-Ion battery. The ambient temperature above which the STBC08 will begin to reduce the 400mA charge current is approximately:

### Equation 5

$$T_A = 120^\circ \text{C} - (5\text{V} - 3.7\text{V}) \cdot (400\text{mA}) \cdot 105 \frac{\text{C}}{\text{W}} = 42^\circ \text{C}$$

The STBC08 can be used above 42°C, but the charge current will be reduced from 400mA. The approximate current at a given ambient temperature can be calculated:

### Equation 6

$$I_{BAT} = \frac{120^\circ \text{C} - T_A}{(V_{CC} - V_{BAT}) \cdot \theta_A}$$

Using the previous example with an ambient temperature of 65°C, the charge current will be reduced to approximately:

### Equation 7

$$I_{BAT} = \frac{120^\circ \text{C} - 65^\circ \text{C}}{(5\text{V} - 3.7\text{V}) \cdot 150 \frac{\text{C}}{\text{W}}} = 282\text{mA}$$

Furthermore, the voltage at the PROG pin will change proportionally with the charge current as discussed in [Section 9.1: Programming charge current](#). It is important to remember that STBC08 applications do not need to be designed for worst-case thermal conditions since the IC will automatically reduce power dissipation when the junction temperature reaches approximately 120°C.

## 6 Automatic recharge

Once the charge cycle is terminated, the STBC08 continuously monitors the voltage on the BAT pin using a comparator with a 2-ms filter time ( $t_{RECHARGE}$ ). A charge cycle restarts when the battery voltage falls below 4.05V (which corresponds to approximately 80% to 90% battery capacity).

This ensures that the battery is kept at or near a fully-charged condition and eliminates the need for periodic charge cycle initiations. The CHRГ output enters a strong pulldown state during recharge cycles.

**Figure 3. State diagram of a typical charge cycle**

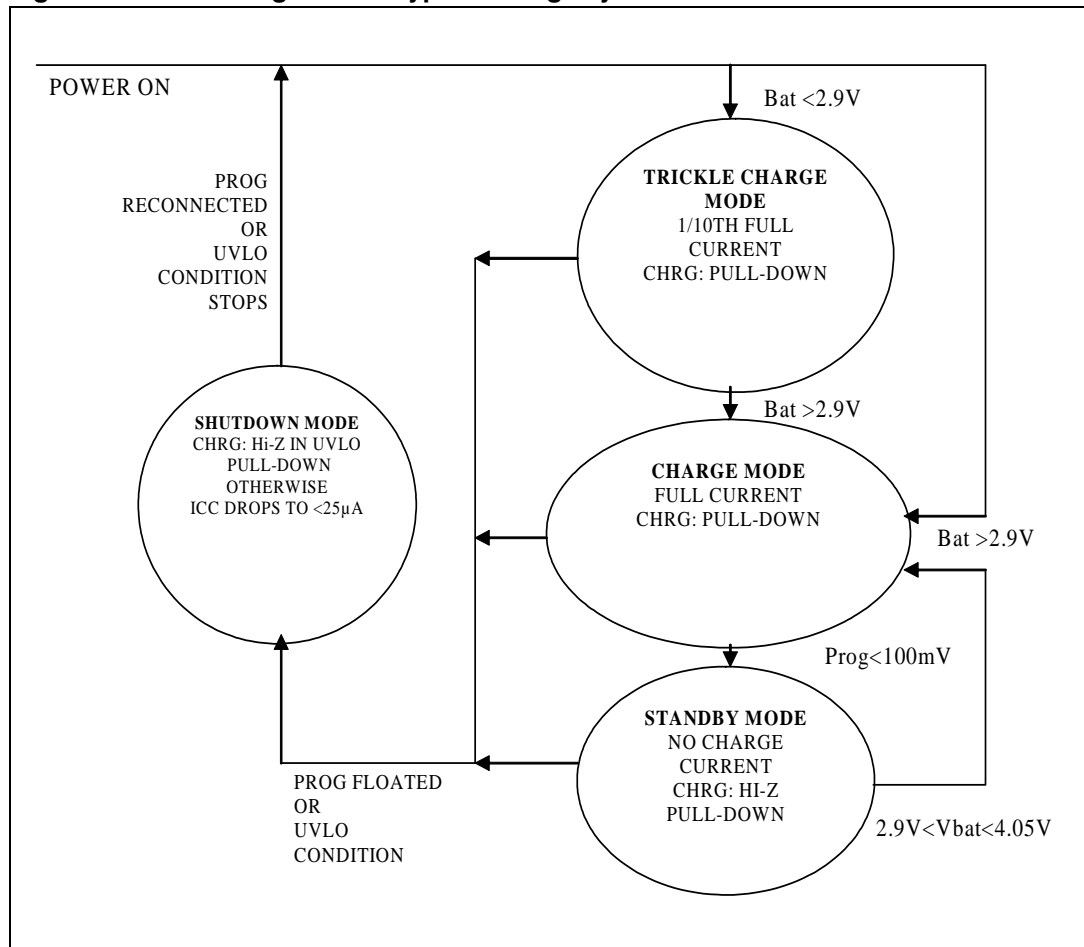



## 7 CHRG and Power-on status output pins

The POWER ON pin (open drain) is a flag that indicates the presence of the  $V_{CC}$ ,  $V_{UVLO} < V_{CC} < 7.2V$  and  $V_{CC} > V_{BAT}$ . High impedance indicates that  $V_{CC} < V_{UVLO}$ ,  $V_{CC} > 7.2V$  or  $V_{CC} < V_{BAT}$ . In this case  $V_{CC}$  is insufficient.

The CHRG pin (open drain) is a flag that indicates the status of the charge, if the pin is low the device works and the charge is going, when the pin is high impedance the charge is finished (constant Voltage and  $I_{PROG}/10$ ).

**Table 3. LEDs status**

		CHRG	
		Low	High
Power-ON	Low	00	01
	High	Not used	11

The values in [Table 3](#) correspond to the following modes:

- 00 is Precharge mode (Trickle Charge mode) or Charge Mode.  $V_{CC}$  is more than  $V_{UVLO}$  and  $R_{PROG}$  is present on the PROG pin.
- 01 is Standby mode (completed charge) or Shutdown mode ( $R_{PROG}$  not connected).
- 11 is Supply (insufficient and unqualified.)

**Figure 4. Using a microprocessor to determine device state**

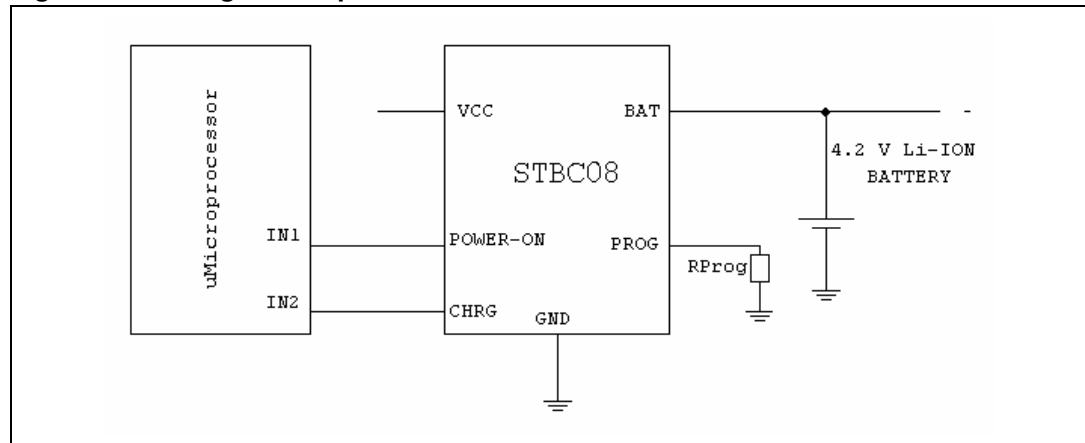

## 8 USB and wall adapter power

Although the STBC08 allows charging from a USB port, a wall adapter can also be used to charge Li-Ion batteries.

*Figure 5* shows an example of how to combine wall adapter and USB power inputs. A P-channel MOSFET is used to prevent back conducting into the USB port when a wall adapter is present and Schottky diode is used to prevent USB power loss through the 1kΩ pull-down resistor. Typically, a wall adapter can supply significantly more current than the 500mA-limited USB port. Therefore, an N-channel MOSFET and an extra program resistor are used to increase the charge current to 850mA when the wall adapter is present.

**Figure 5. Combining wall adapter and USB power**

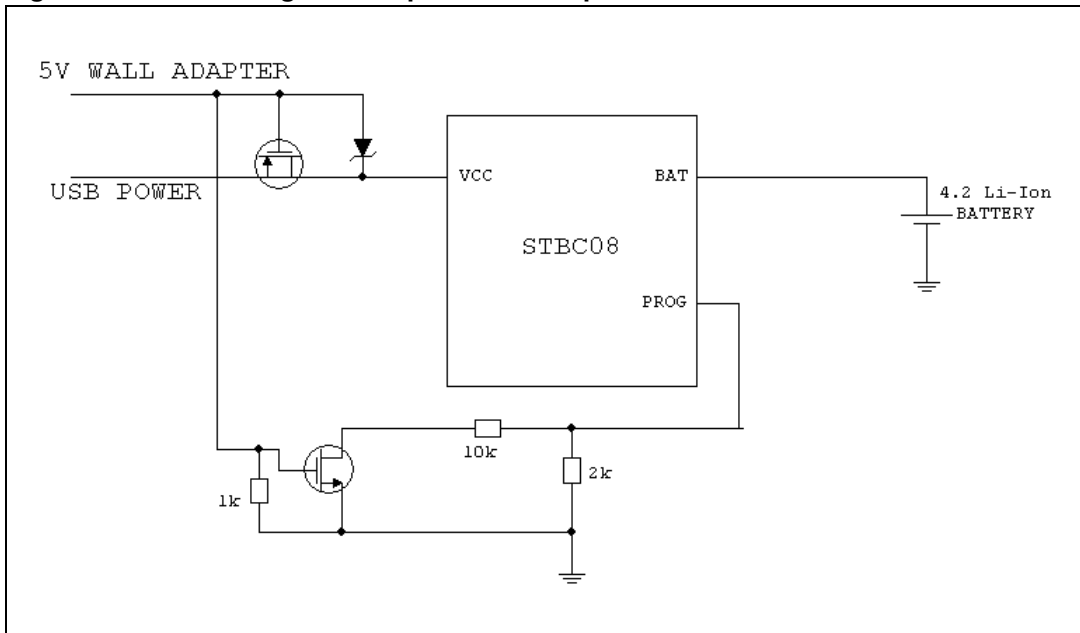

## 9 Charge current

### 9.1 Programming charge current

The charge current is programmed using a single resistor from the PROG pin to ground. The battery charge current is 1000 times the current out of the PROG pin. The program resistor and the charge current are calculated using the following equations:

#### Equation 8

$$R_{\text{PROG}} = 1000 \cdot \frac{1.00\text{V}}{I_{\text{BAT}}}$$

The charge current out of the BAT pin can be determined at any time by monitoring the PROG pin voltage using the following equation:

#### Equation 9

$$I_{\text{BAT}} = \frac{V_{\text{PROG}}}{R_{\text{PROG}}} \cdot 1000$$

### 9.2 Maximum charge current in temperature

Initial conditions:  $V_{\text{IN}} = 4.4\text{V}$ ,  $V_{\text{BAT}} = 3.1\text{V}$ ,  $R_{\text{PROG}} = 1\text{k}\Omega$  and Air flow = 4 l/s.

Figure 6.  $I_{\text{BAT}}$  vs. temperature

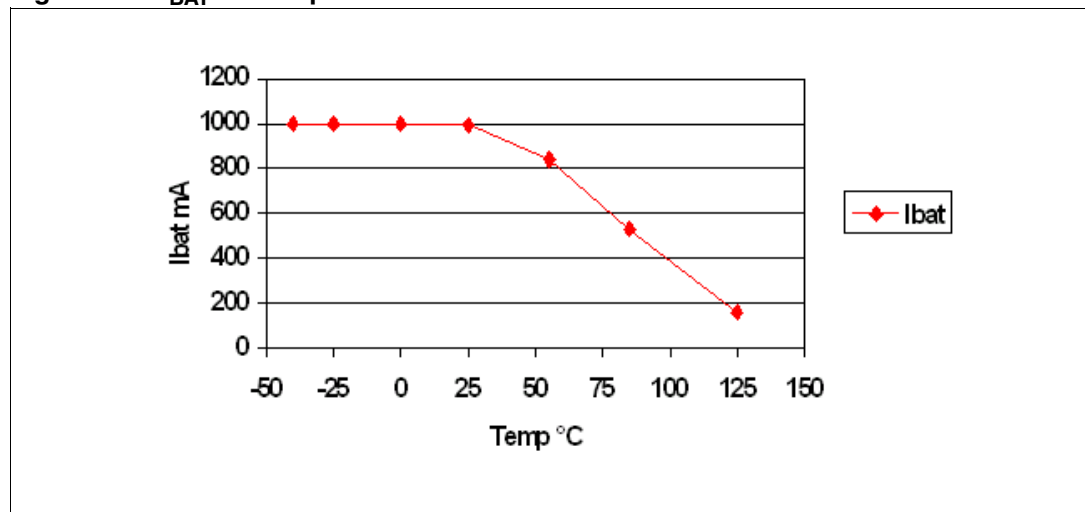

The 1A battery current set by  $R_{\text{PROG}}$  is constant in the  $-40^{\circ}$  to  $25^{\circ}$  C temperature range. For temperatures higher than  $25^{\circ}$  C, the current is lower due to the thermal limit of the device.

## Appendix A Board layout

Figure 7. Top component demo board

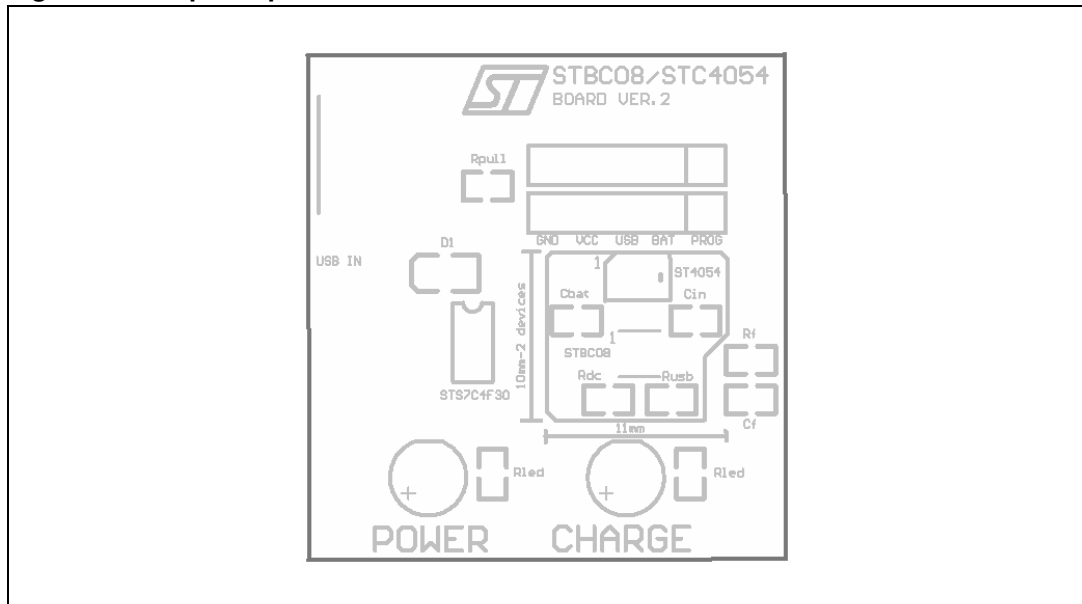

Figure 8. Top layer layout

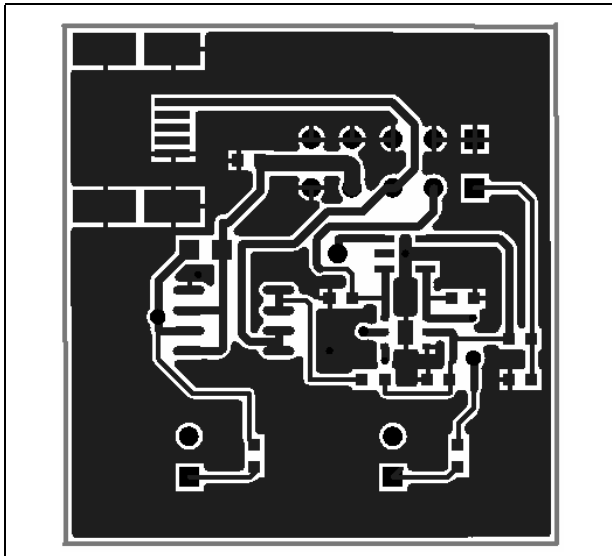
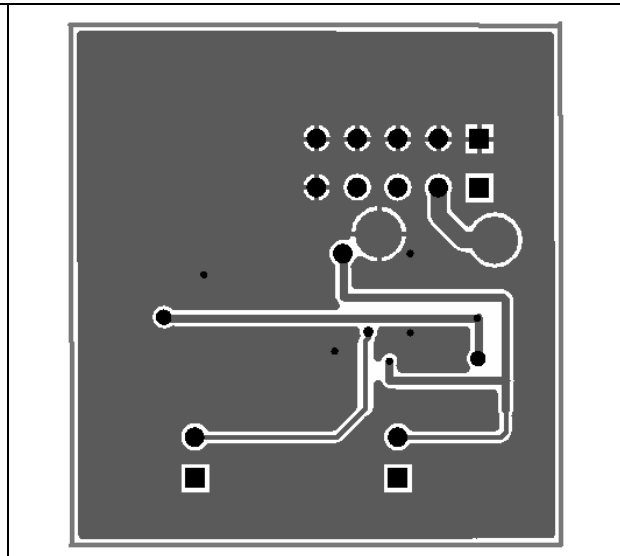

Figure 9. Bottom layer layout



## Revision history

**Table 4. Document revision history**

Date	Revision	Changes
7-Sept-2006	1	Initial release.
19-Sept-2006	2	Table 2 changed

**Please Read Carefully:**

Information in this document is provided solely in connection with ST products. STMicroelectronics NV and its subsidiaries ("ST") reserve the right to make changes, corrections, modifications or improvements, to this document, and the products and services described herein at any time, without notice.

All ST products are sold pursuant to ST's terms and conditions of sale.

Purchasers are solely responsible for the choice, selection and use of the ST products and services described herein, and ST assumes no liability whatsoever relating to the choice, selection or use of the ST products and services described herein.

No license, express or implied, by estoppel or otherwise, to any intellectual property rights is granted under this document. If any part of this document refers to any third party products or services it shall not be deemed a license grant by ST for the use of such third party products or services, or any intellectual property contained therein or considered as a warranty covering the use in any manner whatsoever of such third party products or services or any intellectual property contained therein.

**UNLESS OTHERWISE SET FORTH IN ST'S TERMS AND CONDITIONS OF SALE ST DISCLAIMS ANY EXPRESS OR IMPLIED WARRANTY WITH RESPECT TO THE USE AND/OR SALE OF ST PRODUCTS INCLUDING WITHOUT LIMITATION IMPLIED WARRANTIES OF MERCHANTABILITY, FITNESS FOR A PARTICULAR PURPOSE (AND THEIR EQUIVALENTS UNDER THE LAWS OF ANY JURISDICTION), OR INFRINGEMENT OF ANY PATENT, COPYRIGHT OR OTHER INTELLECTUAL PROPERTY RIGHT.**

**UNLESS EXPRESSLY APPROVED IN WRITING BY AN AUTHORIZED ST REPRESENTATIVE, ST PRODUCTS ARE NOT RECOMMENDED, AUTHORIZED OR WARRANTED FOR USE IN MILITARY, AIR CRAFT, SPACE, LIFE SAVING, OR LIFE SUSTAINING APPLICATIONS, NOR IN PRODUCTS OR SYSTEMS WHERE FAILURE OR MALFUNCTION MAY RESULT IN PERSONAL INJURY, DEATH, OR SEVERE PROPERTY OR ENVIRONMENTAL DAMAGE. ST PRODUCTS WHICH ARE NOT SPECIFIED AS "AUTOMOTIVE GRADE" MAY ONLY BE USED IN AUTOMOTIVE APPLICATIONS AT USER'S OWN RISK.**

Resale of ST products with provisions different from the statements and/or technical features set forth in this document shall immediately void any warranty granted by ST for the ST product or service described herein and shall not create or extend in any manner whatsoever, any liability of ST.

ST and the ST logo are trademarks or registered trademarks of ST in various countries.

Information in this document supersedes and replaces all information previously supplied.

The ST logo is a registered trademark of STMicroelectronics. All other names are the property of their respective owners.

© 2006 STMicroelectronics - All rights reserved

STMicroelectronics group of companies

Australia - Belgium - Brazil - Canada - China - Czech Republic - Finland - France - Germany - Hong Kong - India - Israel - Italy - Japan - Malaysia - Malta - Morocco - Singapore - Spain - Sweden - Switzerland - United Kingdom - United States of America

[www.st.com](http://www.st.com)