**How to use DAC for audio and waveform generation on STM32
MCUs and MPUs**

Introduction

This application note provides some examples for generating audio waveforms using the digital-to-analog converter (DAC) peripheral embedded in STM32 products (see [Table 1](#)).

A digital-to-analog converter (DAC) is a device that performs the opposite function of an analog-to-digital converter, i.e. it converts a digital word to a corresponding analog voltage.

The STM32 DAC module is a 12-bit word converter, with up to three output channels to support audio functions.

The DAC can be used in many audio applications such as security alarms, Bluetooth® headsets, talking toys, answering machines, man-machine interfaces, and low-cost music players.

The STM32 DAC can also be used for many other purposes, such as analog waveform generation and control engineering.

This application note is organized in two main sections:

- [Section 1](#) describes the main features of the STM32 DAC module.
- [Section 2](#) presents two examples.
 - In the first example, the DAC is used to generate a sine waveform
 - In the second example, the DAC is used to generate audio from WAV files

Table 1. Applicable products

| Type | Product categories |
|------------------|--|
| Microcontrollers | STM32 high performance MCUs STM32 mainstream MCUs STM32 ultra low power MCUs STM32WL series |
| Microprocessors | STM32 Arm Cortex MPUs |

Contents

- 1 DAC main features 5**
 - 1.1 Overview 5
 - 1.2 Data format 6
 - 1.3 Dual channel mode 6
 - 1.4 Dedicated timers 6
 - 1.5 DMA capabilities 7
 - 1.6 DMA under run error 8
 - 1.7 White noise generator 8
 - 1.7.1 Definition 8
 - 1.7.2 Typical applications 10
 - 1.8 Triangular wave generator 10
 - 1.8.1 Definition 10
 - 1.8.2 Typical applications 12
 - 1.9 Buffered output 12

- 2 Application examples 14**
 - 2.1 Using the DAC to generate a sine waveform 14
 - 2.1.1 Description 14
 - 2.1.2 Waveform preparation 14
 - 2.1.3 Setting the sine wave frequency 15
 - 2.2 Using the DAC to implement an audio player 17
 - 2.2.1 Description 17
 - 2.2.2 Audio wave file specifications 18
 - 2.2.3 .WAV file format 18
 - 2.3 Audio wave player implementation 18

- 3 Conclusion 21**

- 4 Revision history 22**

List of tables

| | | |
|----------|---|----|
| Table 1. | Applicable products | 1 |
| Table 2. | Preprogrammable triangular waveform amplitude values..... | 11 |
| Table 3. | Digital and analog sample values of the sine wave | 15 |
| Table 4. | Document revision history | 22 |

List of figures

| | | |
|------------|--|----|
| Figure 1. | DAC data format | 6 |
| Figure 2. | STM32F10x DAC trigger channels | 7 |
| Figure 3. | DAC interaction without DMA | 7 |
| Figure 4. | DAC interaction with DMA | 8 |
| Figure 5. | Pseudo random code generator embedded in the DAC | 9 |
| Figure 6. | Noise waveform | 9 |
| Figure 7. | Noise waveform with modifiable offset | 10 |
| Figure 8. | Triangular waveform | 11 |
| Figure 9. | Triangular waveform with changeable offset | 12 |
| Figure 10. | Non buffered channel voltage (with and without load) | 13 |
| Figure 11. | Buffered channel voltage (with and without load) | 13 |
| Figure 12. | Sine wave model samples | 14 |
| Figure 13. | Sine wave generated with ns = 10 | 16 |
| Figure 14. | Sine wave generated with ns = 255 | 16 |
| Figure 15. | Flow of data from microSD memory card to external speakers | 17 |
| Figure 16. | Audio player flowchart | 19 |
| Figure 17. | CPU and DMA activities during wave playing process | 20 |

1 DAC main features

1.1 Overview

STM32 products, based on Arm^{®(a)} Cortex[®] cores, integrate DACs with different configurations and features:

- one to three output channels
- noise waveform generation
- triangular waveform generation
- DMA under run flag
- dedicated analog clock

For the different DAC configurations refer to the product datasheets and to reference manuals. Additional info can be found in AN4566 “*Extending the DAC performance of STM32 microcontrollers*”. All these documents are available on www.st.com.

arm

a. Arm and Cortex are registered trademarks of Arm Limited (or its subsidiaries or affiliates) in the US and/or elsewhere.

The Arm word and logo are trademarks of Arm Limited (or its subsidiaries) in the US and/or elsewhere. All rights reserved.

1.2 Data format

As shown in [Figure 1](#), the DAC accepts data in three integer formats: 8-bit (the LS byte of the data hold register), 12-bit right aligned (the twelve LS bits of the data hold register) and 12-bit left aligned (the twelve MS bits of the data hold register).

Figure 1. DAC data format

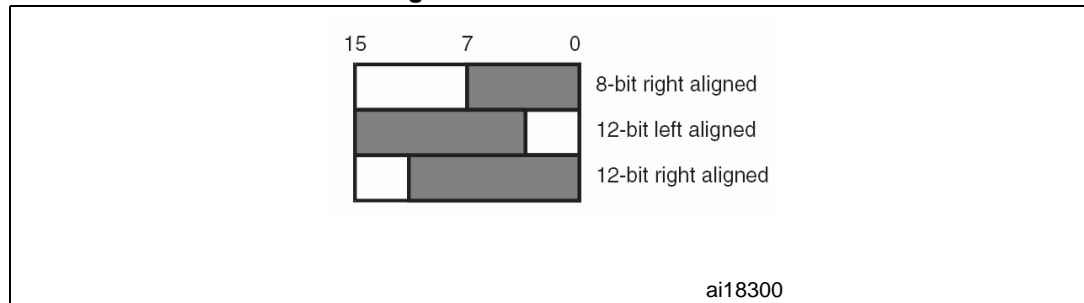

The analog output voltage on each DAC channel output is determined by the equation

$$DAC_{Output} = V_{REF} \times DOR / 4096$$

1.3 Dual channel mode

Note: This feature is supported only for products that embed at least two DACs.

The DAC has two output channels, each with its own converter. In dual DAC channel mode, conversions can be done independently or simultaneously.

When the DAC channels are triggered by the same source, both channels are grouped together for synchronous update operations and conversions are done simultaneously.

1.4 Dedicated timers

In addition to the software and external triggers, the DAC conversion can be triggered by different timers.

TIM6 and TIM7 are basic timers and are intended for DAC triggering.

Each time a DAC interface detects a rising edge on the selected timer trigger output (TIMx_TRGO), the last data stored in the DAC_DHRx register is transferred to the DAC_DORx register (an example for STM32F100x is given in [Figure 2](#)).

Figure 2. STM32F10x DAC trigger channels

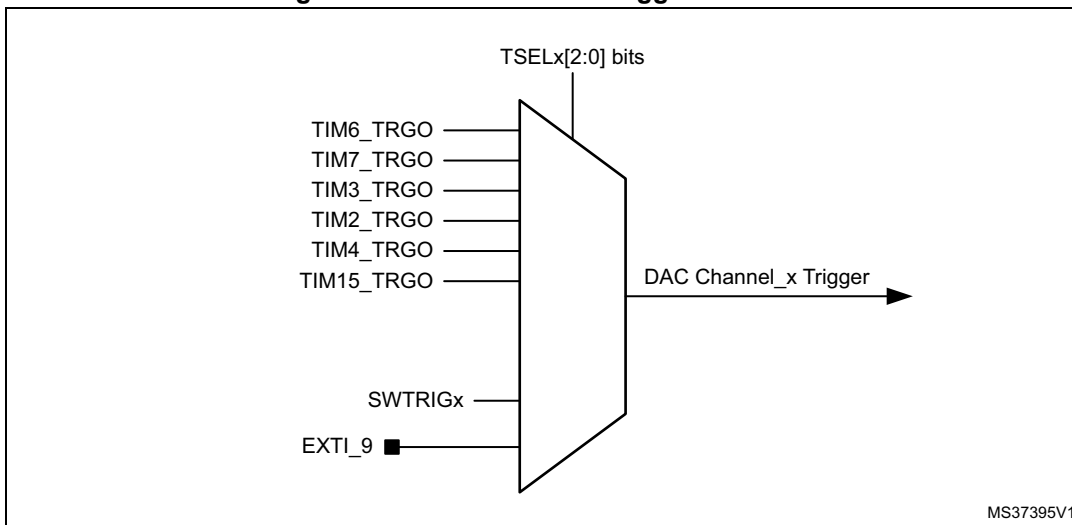

1.5 DMA capabilities

The STM32 products have at least one DMA module with multiple channels (streams).

Each DAC channel (stream) is connected to an independent DMA channel. As an example, for STM32F10x microcontrollers, DAC channel1 is connected to the DMA channel3 and DAC channel2 is connected to DMA channel4.

When DMA is not used, the CPU is used to provide DAC with the digital code relevant to the waveform to generate. This code is saved in a RAM, or in an embedded NV memory, and the CPU transfers the data from the memory to the DAC.

Figure 3. DAC interaction without DMA

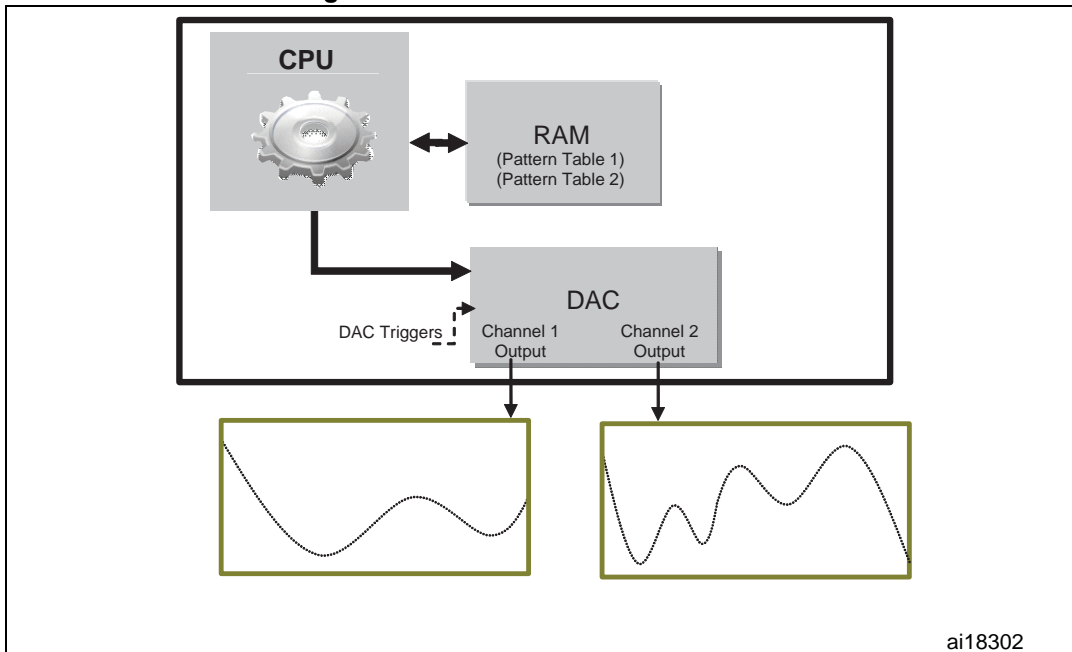

When using the DMA, the overall performance of the system is increased by freeing up the CPU. This is because data is moved from memory to DAC by DMA, without need for any action by the CPU. This keeps CPU resources available for other operations.

Figure 4. DAC interaction with DMA

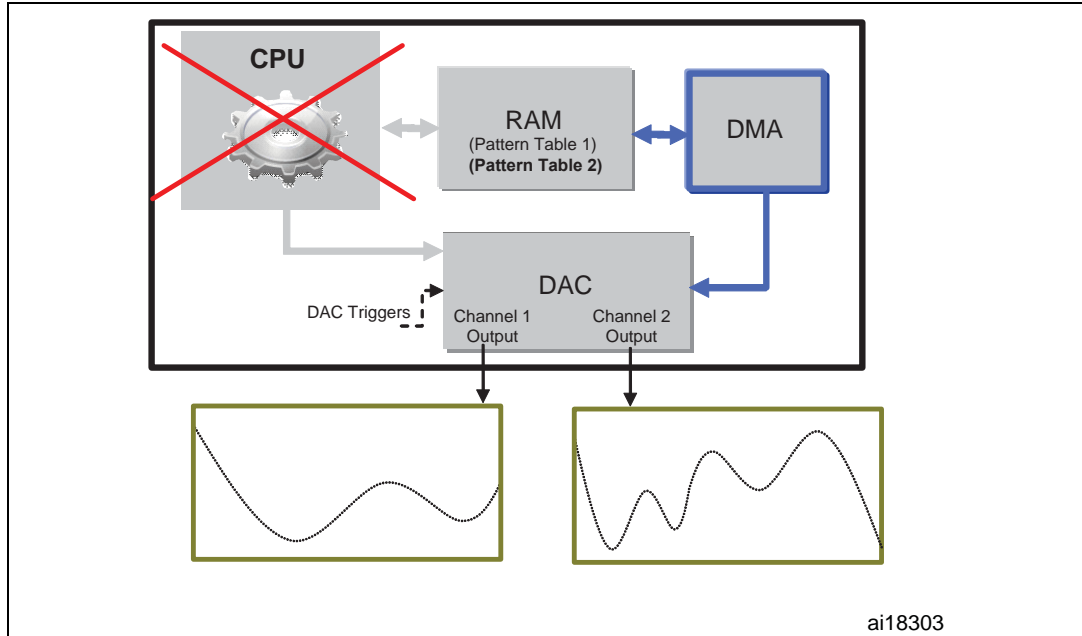

1.6 DMA under run error

When the DMA is used to provide DAC with the waveform digital code, there are cases where the DMA transfer is slower than the DAC conversion. In these cases, the DAC detects that a part of the pattern waveform has not been received and cannot be converted, and then sets the “DMA under run error” flag.

1.7 White noise generator

1.7.1 Definition

The STM32 DACs feature a pseudo random code generator, sketched in [Figure 5](#). Depending on what taps are used on the shift register, a sequence of up to 2^{n-1} numbers can be generated before the sequence repeats.

Figure 5. Pseudo random code generator embedded in the DAC

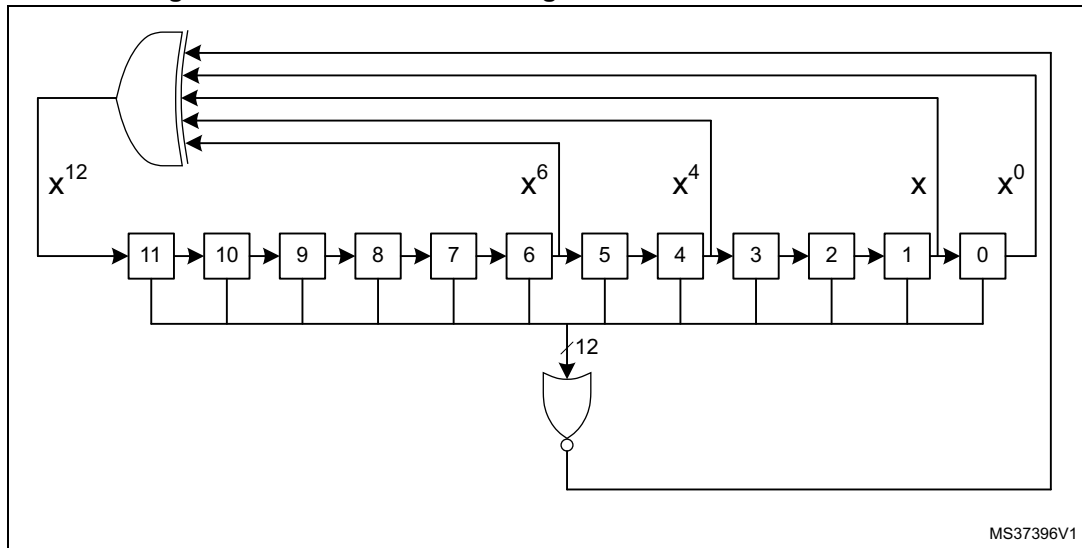

The noise produced by this generator has a flat spectral distribution and can be considered white noise. However, instead of having a Gaussian output characteristics, it is uniformly distributed, see [Figure 6](#).

Figure 6. Noise waveform

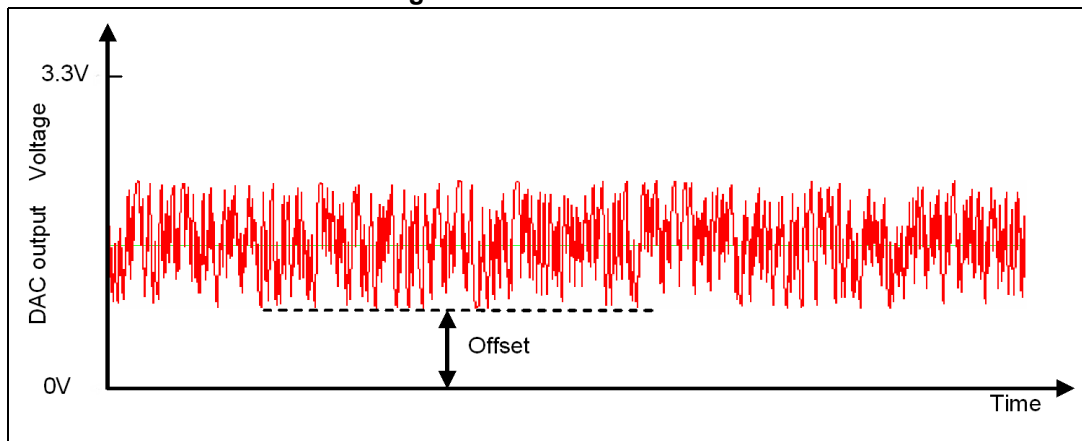

The offset (or DC bias) of the noise waveform is programmable. By varying this offset with a preconfigured table of offsets (signal pattern), the user can obtain a waveform that corresponds to the sum of the signal pattern and the noise waveform.

Figure 7. Noise waveform with modifiable offset

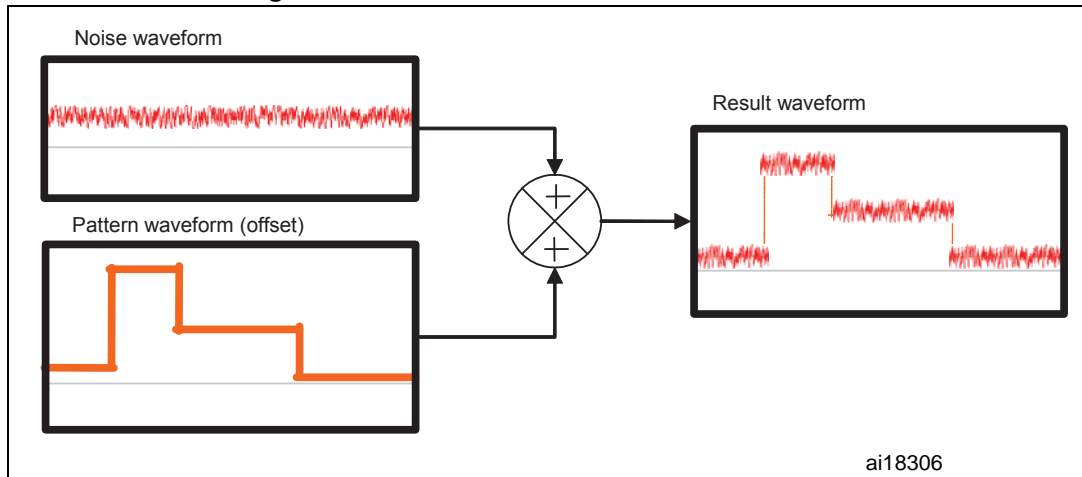

1.7.2 Typical applications

STM32 products come with 12-bit enhanced ADCs with a sampling rate that can exceed 1 M samples/s. In most applications, this resolution is sufficient, when higher accuracy is required, the concept of oversampling and decimating the input signal can be implemented to save the use of an external ADC solution and to reduce the application power consumption. This noise waveform can be used to enhance the ADC accuracy with the oversampling method.

More details about these methods are explained in the application note AN2668, available on www.st.com, in the section titled “Oversampling using white noise”.

The white noise generator can be also used in the production of electronic music, either directly or as an input for a filter to create other types of noise signals. It is used extensively in audio synthesis, typically to recreate percussive instruments such as cymbals, which have high noise content in their frequency domain.

White noise generator can be used for control engineering purposes, e.g. for frequency response testing of amplifiers and electronic filters.

1.8 Triangular wave generator

1.8.1 Definition

The STM32 DAC provides the user with a triangular waveform generator with flexible offset, amplitude and frequency.

The amplitude of the triangular waveform can be fixed using the MAMPx bits in the DAC_CR register.

Table 2. Preprogrammable triangular waveform amplitude values

| MAMPx[3:0] bits | Digital amplitude | Analog amplitude (Volt) (with $V_{REF+} = 3.3\text{ V}$) |
|-----------------|-------------------|--|
| 0 | 1 | 0.0008 |
| 1 | 3 | 0.0024 |
| 2 | 7 | 0.0056 |
| 3 | 15 | 0.0121 |
| 4 | 31 | 0.0250 |
| 5 | 63 | 0.0508 |
| 6 | 127 | 0.1023 |
| 7 | 255 | 0.2054 |
| 8 | 511 | 0.4117 |
| 9 | 1023 | 0.8242 |
| 10 | 2047 | 1.6492 |
| ≥ 11 | 4095 | 3.2992 |

For more details about the triangular waveform refer to the dedicated sections in the reference manuals.

The triangular waveform frequency is related to the frequency of the trigger source.

Figure 8. Triangular waveform

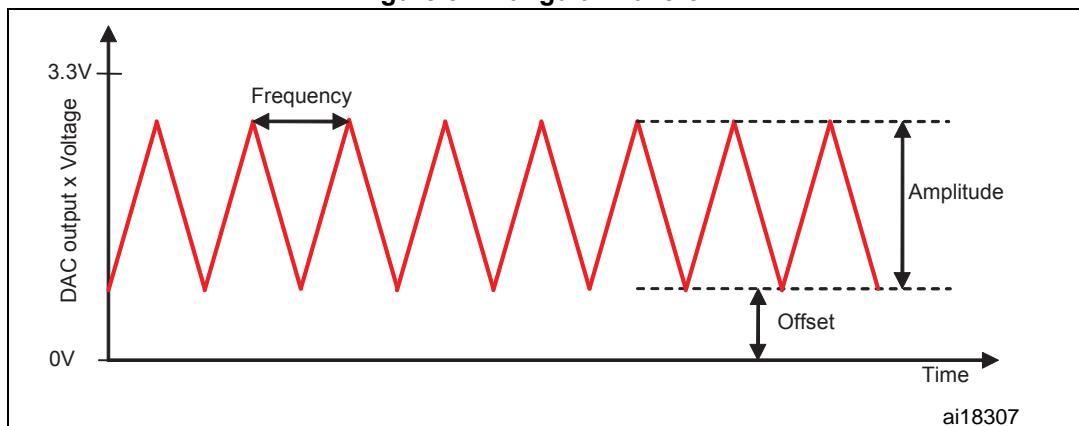

The offset of the triangular waveform is programmable (see [Figure 9](#)). By varying the offset of the triangular waveform with a preconfigured table of offsets (signal pattern), user can obtain a waveform that corresponds to the sum of the signal pattern and the triangular waveform. As there is no hardware overflow protection, the sum of offsets and amplitude must not be higher than 4095.

Figure 9. Triangular waveform with changeable offset

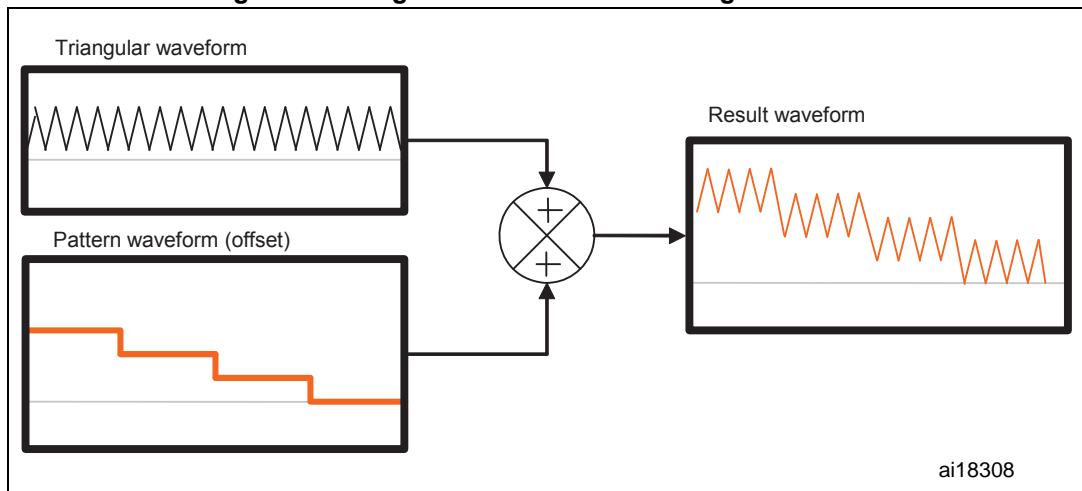

1.8.2 Typical applications

Triangular wave generators are often used in sound synthesis as their timbre is less harsh than the square wave (the amplitude of its upper harmonics falls off more rapidly).

1.9 Buffered output

To drive external loads without using an external amplifier, DAC channels have embedded output buffers that can be enabled and disabled depending on the user application.

When the DAC output is not buffered, and there is a load in the user application circuit, the voltage output is lower than the desired voltage (*Figure 10*), because of the significant DAC output impedance. Refer to the relevant STM32 datasheet for the specification of DAC output impedance (for example, for STM32F4 products, the resistive load resistance must be higher than 1.5 MΩ to have an output voltage drop below 1% of the output signal voltage).

When enabling the buffer, the output and the desired voltages are similar (*Figure 11*).

Figure 10. Non buffered channel voltage (with and without load)

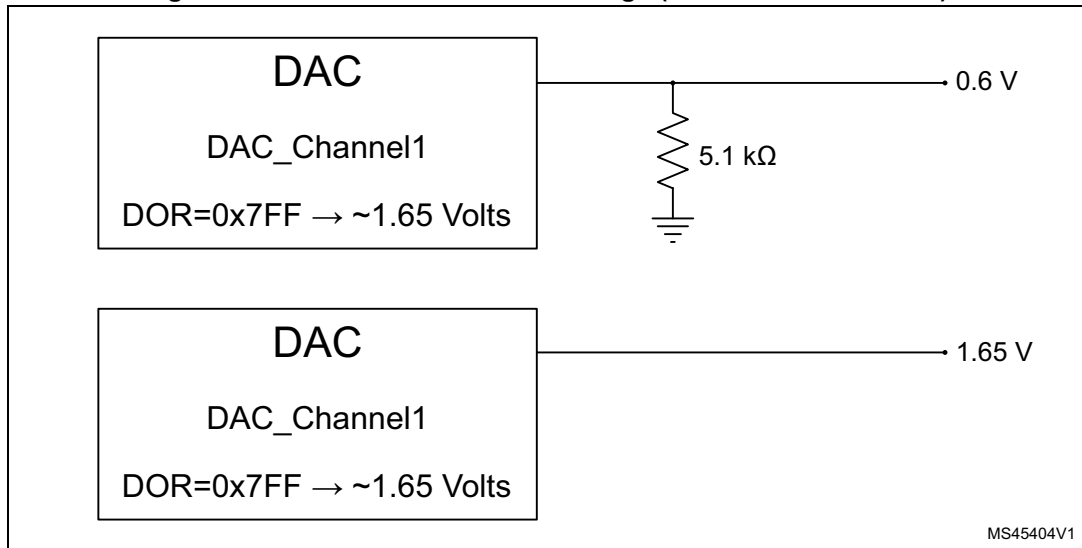
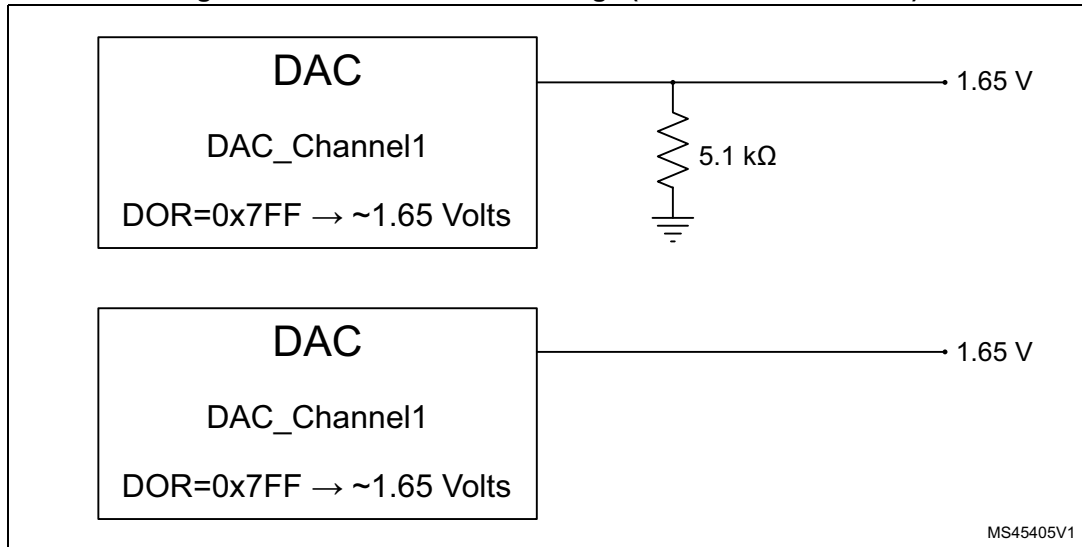

Figure 11. Buffered channel voltage (with and without load)



2 Application examples

2.1 Using the DAC to generate a sine waveform

2.1.1 Description

This example describes step by step how to generate a sine waveform.

A sine waveform is also called a monotone signal, it is known as a pure (or sine) tone. The sine tones are traditionally used as stimuli to assess the response of the audio system.

2.1.2 Waveform preparation

To prepare the digital pattern of the waveform, we have to go through some mathematics.

Our objective is to have ten digital pattern data (samples) of a sine wave form that varies from 0 to 2π .

Figure 12. Sine wave model samples

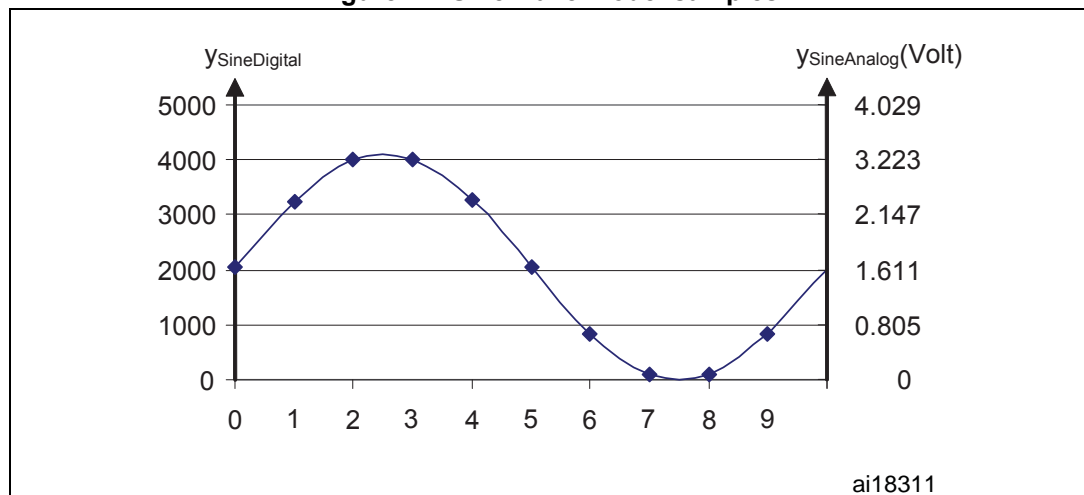

The sampling step is $2\pi / n_s$ (number of samples).

The value of $\sin(x)$ varies between -1 and 1, we have to shift it up to have a positive sine wave with samples varying between 0 and 0xFFF (corresponding to the 0 to 3.3 V voltage range, where V_{REF} is set to 3.3 V).

$$y_{SineDigital}(x) = \left(\sin\left(x \cdot \frac{2\pi}{n_s}\right) + 1 \right) \left(\frac{0xFFF + 1}{2} \right)$$

Digital inputs are converted to output voltages on a linear conversion between 0 and V_{REF+} .

The analog output voltages on each DAC channel pin are determined by the equation

$$DAC_{Output} = V_{REF} \frac{DOR}{DAC_MaxDigitalValue + 1}$$

Note: For right-aligned 12-bit resolution: $DAC_MaxDigitalValue = 0xFFF$
 For right-aligned 8-bit resolution: $DAC_MaxDigitalValue = 0xFF$

So the analog sine waveform $y_{\text{SineAnalog}}$ can be determined by the following equation

$$y_{\text{SineAnalog}}(x) = 3.3\text{Volt} \frac{Y_{\text{SineDigital}}(x)}{0\text{xFFF} + 1}$$

Table 3. Digital and analog sample values of the sine wave

| Sample (x) | Digital sample value $Y_{\text{SineDigital}}(x)$ | Analog sample value (Volt) $Y_{\text{SineAnalog}}(x)$ |
|------------|---|--|
| 0 | 2048 | 1.650 |
| 1 | 3251 | 2.620 |
| 2 | 3995 | 3.219 |
| 3 | 3996 | 3.220 |
| 4 | 3253 | 2.622 |
| 5 | 2051 | 1.653 |
| 6 | 847 | 0.682 |
| 7 | 101 | 0.081 |
| 8 | 98 | 0.079 |
| 9 | 839 | 0.676 |

The table is saved in the memory and transferred by the DMA, the transfer is triggered by the same timer that triggers the DAC.

2.1.3 Setting the sine wave frequency

To set the frequency of the sine wave signal, the user has to set the frequency ($f_{\text{TimerTRGO}}$) of the timer trigger output.

The frequency of the produced sine wave is

$$f_{\text{Sinewave}} = \frac{f_{\text{TimerTRGO}}}{n_s}$$

So, if the TIMx_TRGO output frequency is 1 MHz, the frequency of the sine wave generated by the DAC is 100 kHz.

Note: To get close to the targeted monotone waveform, it is recommended to use the highest possible number of samples n_s (the difference can be easily understood by comparing [Figure 13](#) with [Figure 14](#)).

Figure 13. Sine wave generated with $n_s = 10$

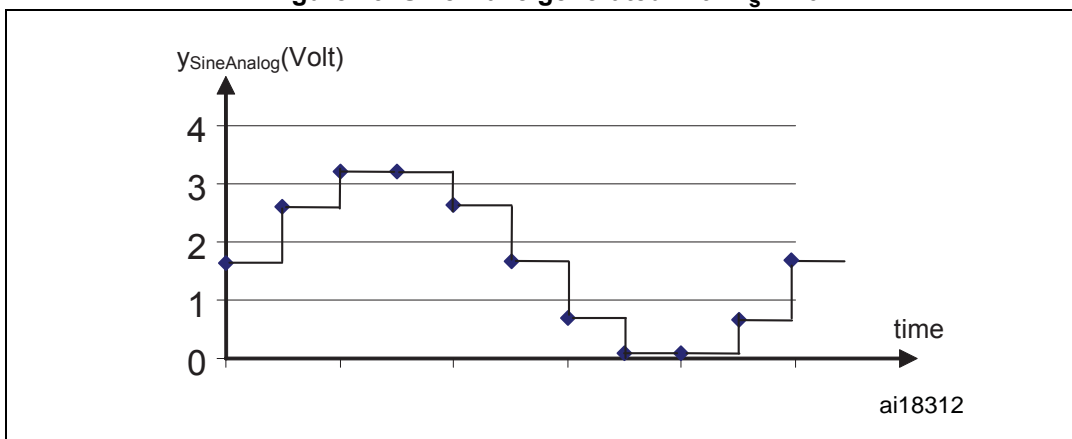
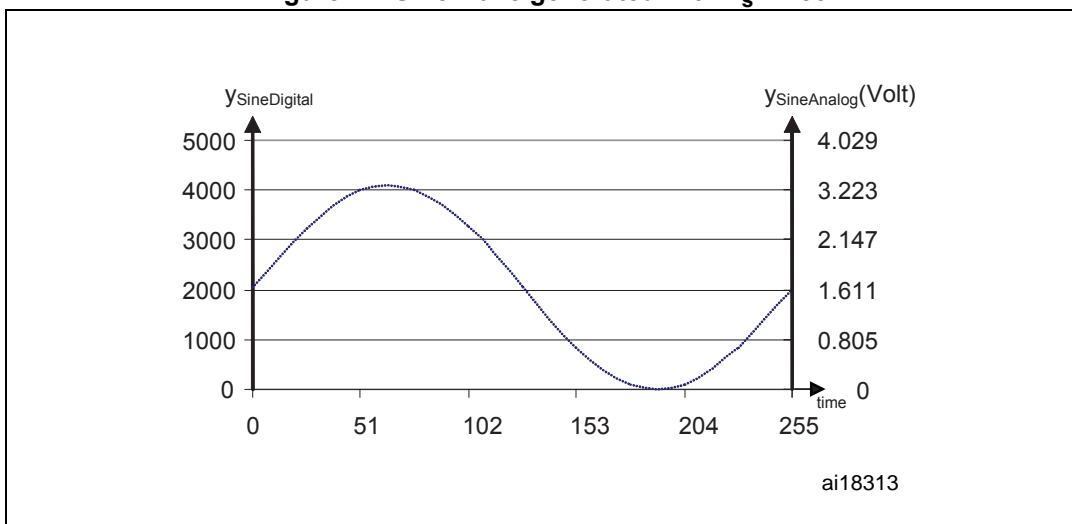

Figure 14. Sine wave generated with $n_s = 255$



2.2 Using the DAC to implement an audio player

2.2.1 Description

The purpose of this demonstration is to provide an audio player solution based on STM32 products to play .WAV files. The approach is optimized to use a minimum number of external components, and offers to end-users the possibility of using their own .WAV files. The audio files are stored in a microSD memory card, accessible by the STM32 through the SPI bus.

Figure 15. Flow of data from microSD memory card to external speakers

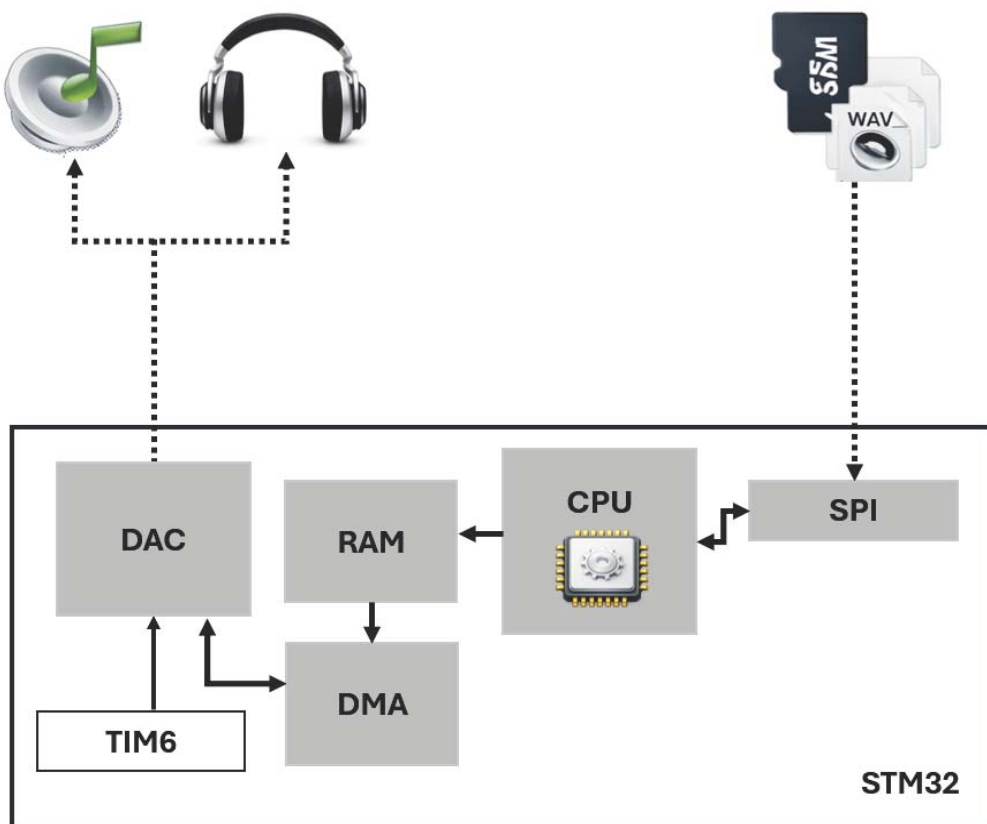

MSv80420V1

The audio player demonstration described in this section is a part of the STM32100B-EVAL demonstration firmware, which can be downloaded, together with the associated user manual (UM1011), from the STMicroelectronics website www.st.com.

2.2.2 Audio wave file specifications

This application assumes that the .WAV file to be played has the following format:

- audio format: PCM (an uncompressed wave data format in which each value represents the amplitude of the signal at the time of sampling)
- sample rate: may be 8000, 11025, 22050 or 44100 Hz
- bits per sample: 8-bit (audio sample data values are in the range [0-255])
- number of channels: 1 (mono)

2.2.3 .WAV file format

The .WAV file format is a subset of the Resource Interchange File Format (RIFF) specification used for the storage of multimedia files. A RIFF file starts with a file header followed by a sequence of data chunks. A .WAV file is often just a RIFF file with a single "WAVE" chunk consisting of two sub-chunks:

1. a **fmt** chunk, specifying the data format
2. a **data** chunk, containing the actual sample data.

The WAVE file format starts with the RIFF header: it indicates the file length.

Next, the fmt chunk describes the sample format, it contains information about the format of the wave audio (PCM / ...), the number of channels (mono/stereo), the sample rate (number of samples per seconds, e.g. 22050), and the sample data size (e.g. 8 bit / 16 bit). Finally, the data chunk contains the sample data.

2.3 Audio wave player implementation

The Audio wave player application is based on the SPI, DMA, TIM6, and DAC peripherals.

At start up, the application first uses the SPI to interface with the microSD card and parses its content, using the DOSFS file system, looking for available .WAV files in the USER folder. Once a valid .WAV file is found, it is read back through the SPI, and the data are transferred using the CPU to a buffer array located in the RAM. The DMA is used to transfer data from RAM to DAC peripheral. TIM6 is used to trigger the DAC that will convert the audio digital data to an analog waveform.

Before the audio data can be played, the header of the .WAV file is parsed so that the sampling rate of the data and their length can be determined.

The task of reproducing audio is achieved by using sampled data (data contained in the .WAV file) to update the value of the DAC output, these data are coded in 8 bits (with values from 0 to 255).

The DAC Channel1 is triggered by TIM6 at regular intervals, specified by the sample rate of the .WAV file header.

The .WAV files are read from the microSD™ card already formatted with a DOSFS file system.

In the demonstration source code project the audio player routines are included in the C-language files `waveplayer.c` and `waveplayer.h`.

The audio player task starts by invoking the `WavePlayerMenu_Start()` function described in [Figure 16](#).

Figure 16. Audio player flowchart

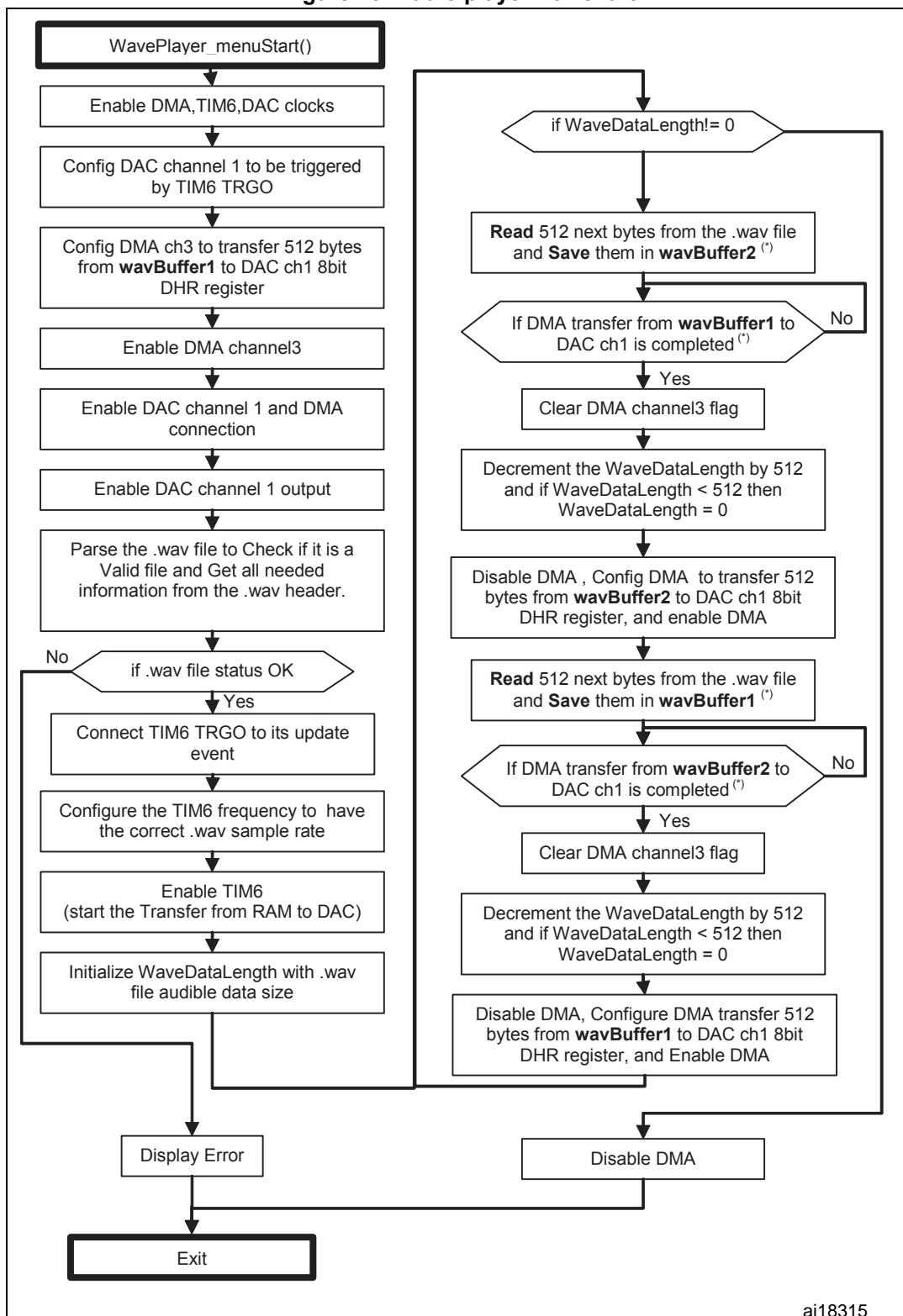

When DMA transfers data from one SRAM buffer, the CPU transfers data from the microSD™ Flash memory to the other SRAM buffer.

In this application, co-processing is mandatory to permit a simultaneous read (from the external memory) and write (in the DAC register) of the waveform digital code.

Figure 17. CPU and DMA activities during wave playing process

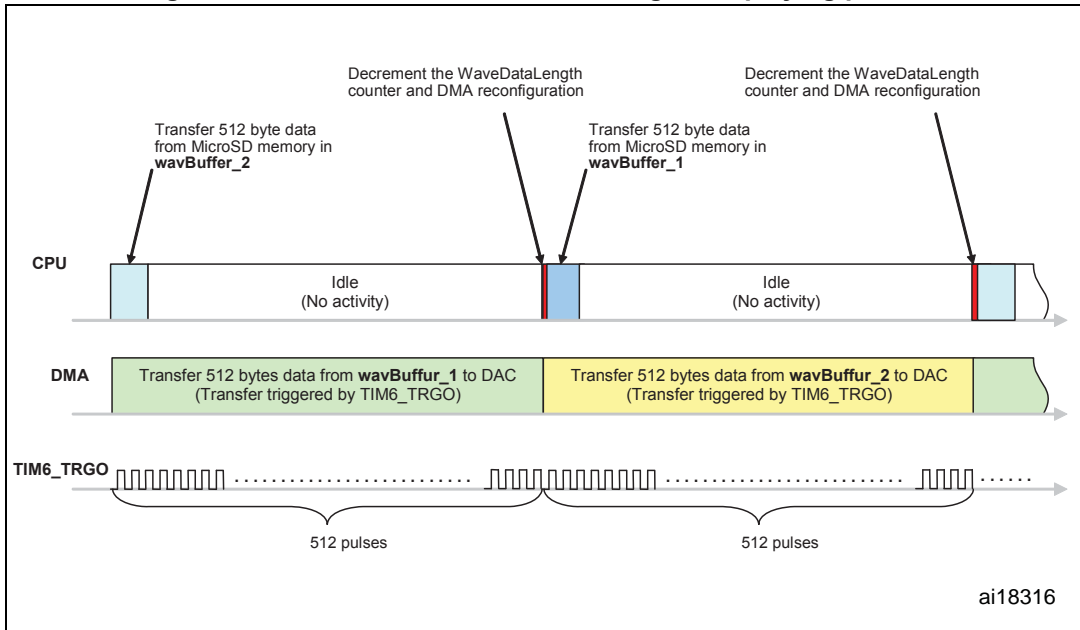

3 Conclusion

This application note and in particular the examples given in [Section 2: Application examples](#) help the user to become familiar with the DACs main features.

The first example ([Section 2.1: Using the DAC to generate a sine waveform](#)) shows how to generate an analog waveform (a sine waveform generation source code is provided as reference). The second example ([Section 2.2: Using the DAC to implement an audio player](#)) offers a straightforward and flexible solution to use the STM32 to play .WAV files stored in an SPI microSD™ Flash memory.

These examples can be used as starting points to develop your own solution based on STM32 products.

4 Revision history

Table 4. Document revision history

| Date | Revision | Changes |
|-------------|----------|---|
| 28-May-2010 | 1 | Initial release. |
| 16-Apr-2015 | 2 | Updated <i>Introduction</i> , <i>Section 1.3: Dual channel mode</i> and <i>Section 3: Conclusion</i> . Updated formulas in <i>Section 2.1.2: Waveform preparation</i> . Updated <i>Figure 2: STM32F10x DAC trigger channels</i> and <i>Figure 5: Pseudo random code generator embedded in the DAC</i> . Added <i>Table 1: Applicable products</i> and <i>Table 2: DAC configuration for STM32 microcontrollers</i> . Added <i>Section 1.1: Overview</i> and <i>Note in Section 1.3: Dual channel mode</i> . |
| 11-May-2017 | 3 | Introduced STM32H7 Series, hence updated <i>Table 1: Applicable products</i> and <i>Table 2: DAC configuration for STM32 microcontrollers</i> . Updated <i>Introduction</i> , <i>Section 1.2: Data format</i> , <i>Section 1.5: DMA capabilities</i> , <i>Section 1.6: DMA under run error</i> , <i>Section 1.7.2: Typical applications</i> , <i>Section 1.8.1: Definition</i> , <i>Section 1.9: Buffered output</i> , <i>Section 2.1.1: Description</i> , <i>Section 2.1.2: Waveform preparation</i> , <i>Section 2.1.3: Setting the sine wave frequency</i> , <i>Section 2.2.1: Description</i> , <i>Section 2.3: Audio wave player implementation</i> and <i>Section 3: Conclusion</i> . Updated <i>Table 1: Preprogrammable triangular waveform amplitude values</i> . Updated <i>Figure 10: Non buffered channel voltage (with and without load)</i> , <i>Figure 11: Buffered channel voltage (with and without load)</i> and <i>Figure 15: Flow of data from microSD memory card to external speakers</i> . Updated second equation in <i>Section 2.1.2: Waveform preparation</i> . |
| 03-Jul-2020 | 4 | Document extended to all STM32 products, hence updated document title, <i>Introduction</i> and <i>Table 1: Applicable products</i> . Removed former <i>Table 2: DAC configuration for STM32 microcontrollers</i> . Minor text edits across the whole document. |
| 25-Feb-2026 | 5 | Updated: <ul style="list-style-type: none"> • Document title. • Table 1: Applicable products. • Section 2.2.1: Description. • Figure 15: Flow of data from microSD memory card to external speakers. |

IMPORTANT NOTICE – PLEASE READ CAREFULLY

STMicroelectronics NV and its subsidiaries (“ST”) reserve the right to make changes, corrections, enhancements, modifications, and improvements to ST products and/or to this document at any time without notice.

In the event of any conflict between the provisions of this document and the provisions of any contractual arrangement in force between the purchasers and ST, the provisions of such contractual arrangement shall prevail.

The purchasers should obtain the latest relevant information on ST products before placing orders. ST products are sold pursuant to ST’s terms and conditions of sale in place at the time of order acknowledgment.

The purchasers are solely responsible for the choice, selection, and use of ST products and ST assumes no liability for application assistance or the design of the purchasers’ products.

No license, express or implied, to any intellectual property right is granted by ST herein.

Resale of ST products with provisions different from the information set forth herein shall void any warranty granted by ST for such product.

If the purchasers identify an ST product that meets their functional and performance requirements but that is not designated for the purchasers’ market segment, the purchasers shall contact ST for more information.

ST and the ST logo are trademarks of ST. For additional information about ST trademarks, refer to www.st.com/trademarks. All other product or service names are the property of their respective owners.

Information in this document supersedes and replaces information previously supplied in any prior versions of this document.

© 2026 STMicroelectronics – All rights reserved