



## Using STM32L1 analog comparators in application cases

---

### Introduction

This document describes six application cases of the two analog comparators embedded in the ultra low power STM32L1 product line. The application cases are:

- Analog voltage monitoring
- Analog watchdog during Stop mode
- Pulse width measurement
- Pulse width modulation (PWM) signal control
- Capacitance measurement
- Brightness control using a light dependent resistor (LDR)

The six application cases demonstrate the usefulness of analog comparators and show how they are integrated with other peripherals, for example, the digital-to-analog-converter (DAC) and timers.

To ensure a quick start, four application cases presented in this document are implemented in C language and are available in *Project\STM32L1xx\_StdPeriph\_Examples\COMP* within the *STM32L1xx\_StdPeriph\_Lib* package.

Please note that this document is not intended to replace the routing interface (RI) and comparator sections in the product reference manual RM0038 (for STM32L1xx Ultra Low Power devices).

The peripheral power consumption should be consulted in the device datasheets.

# Contents

1	Analog voltage monitoring .....	4
2	Analog watchdog during Stop mode .....	7
3	Pulse width measurement .....	9
4	PWM signal control .....	11
5	Capacitance measurement .....	12
6	Brightness control using a light dependent resistor (LDR) .....	14
7	Revision history .....	16

## List of figures

Figure 1.	Sensor output connection to COMP2 . . . . .	4
Figure 2.	Sensor output connection to COMP1 . . . . .	5
Figure 3.	Power consumption in an analog voltage monitoring application . . . . .	5
Figure 4.	COMP2 configuration . . . . .	6
Figure 5.	Analog comparators combined in window mode . . . . .	7
Figure 6.	Analog watchdog during Stop mode . . . . .	8
Figure 7.	COMP2 with output redirection feature . . . . .	9
Figure 8.	Pulse width measurement: COMP2 output redirection to timer . . . . .	10
Figure 9.	PWM signal control: COMP2 output redirection to timer . . . . .	11
Figure 10.	RC network connection for capacitance measurement . . . . .	12
Figure 11.	Capacitance measurement using COMP2 . . . . .	13
Figure 12.	Connecting an LDR resistor to an STM32L1 device . . . . .	14
Figure 13.	Comparator output behavior versus light intensity . . . . .	15

# 1 Analog voltage monitoring

Ultra low power STM32L1 devices embed a 12-bit analog-to-digital converter (ADC) which is very fast with a sampling rate of 1 Msample/s. However, with a 1.45 mA typical consumption, it can jeopardize battery life time if left powered-on continuously. It is therefore recommended to use analog comparators in application cases when analog input voltage (sensor output) needs to be measured as soon as a pre-defined threshold is exceeded.

In STM32L1 devices, analog comparators are useful for monitoring the analog input voltage and powering on the ADC when it is required. While monitoring the analog voltage, the device can enter Stop mode at the same time that both comparators are still powered on. Consequently, better consumption is achieved and power is saved.

*Note:* Analog comparators are powered by the internal reference voltage,  $V_{REFINT}$ , which is still powered on in Stop mode, and can be disabled by configuration. Once  $V_{REFINT}$  is disabled, the comparators can no longer be used.

In an analog voltage monitoring application, where the sensor output voltage is lower than the threshold, the MCU remains in Stop mode thereby saving power. As soon as the sensor output exceeds the threshold, the MCU is woken up, the ADC is powered on, and the analog input voltage is measured. When the sensor output is under the threshold, the MCU re-enters Stop mode.

Average power consumption is dramatically reduced when compared with an application that continuously measures the analog voltage whatever the input value.

Figure 1 shows how to connect a sensor output (temperature sensor, pressure sensor, pyroelectric infrared detector, photodiode sensor) to an STM32L1 device in an analog voltage monitoring application using comparator 2 (COMP2). COMP2 monitors the analog voltage in Stop mode while the ADC measures it in Run mode.

**Figure 1. Sensor output connection to COMP2**

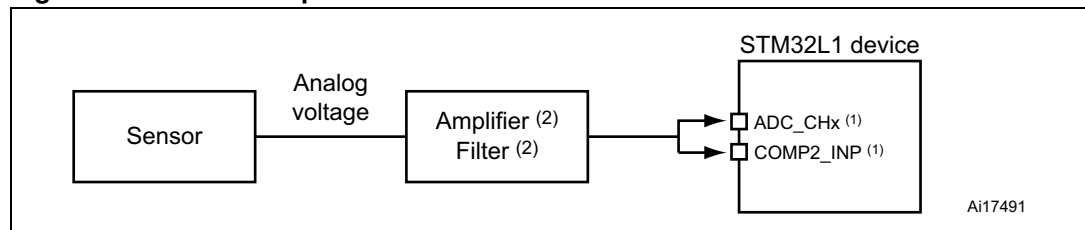

1. Legend for Figure 1  
 ADC\_CHx: AC channel x  
 COMP2\_INP: comparator 2 non-inverting input
2. Only if required.

Figure 2 shows how to connect a sensor output to an STM32L1 device using comparator 1 (COMP1). COMP1 shares the same inputs as the ADC which reduces the number of required pins. Nevertheless, the threshold is fixed to  $V_{REFINT}$ .

**Figure 2. Sensor output connection to COMP1**

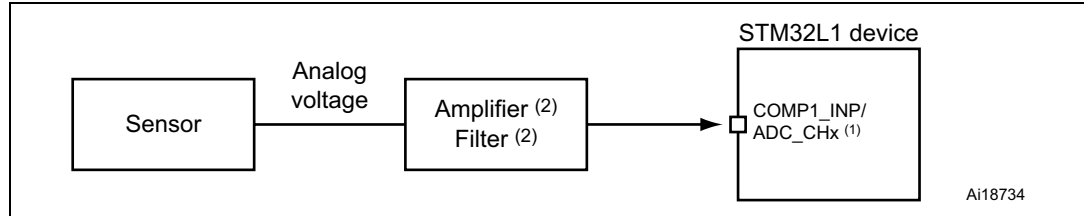

1. Legend for Figure 2  
COMP1\_INP/ADC CHx: comparator 1 non-inverting input shared with ADC channel x
2. Only if required.

Figure 3 shows the gain in power consumption in an analog monitoring application.

**Figure 3. Power consumption in an analog voltage monitoring application**

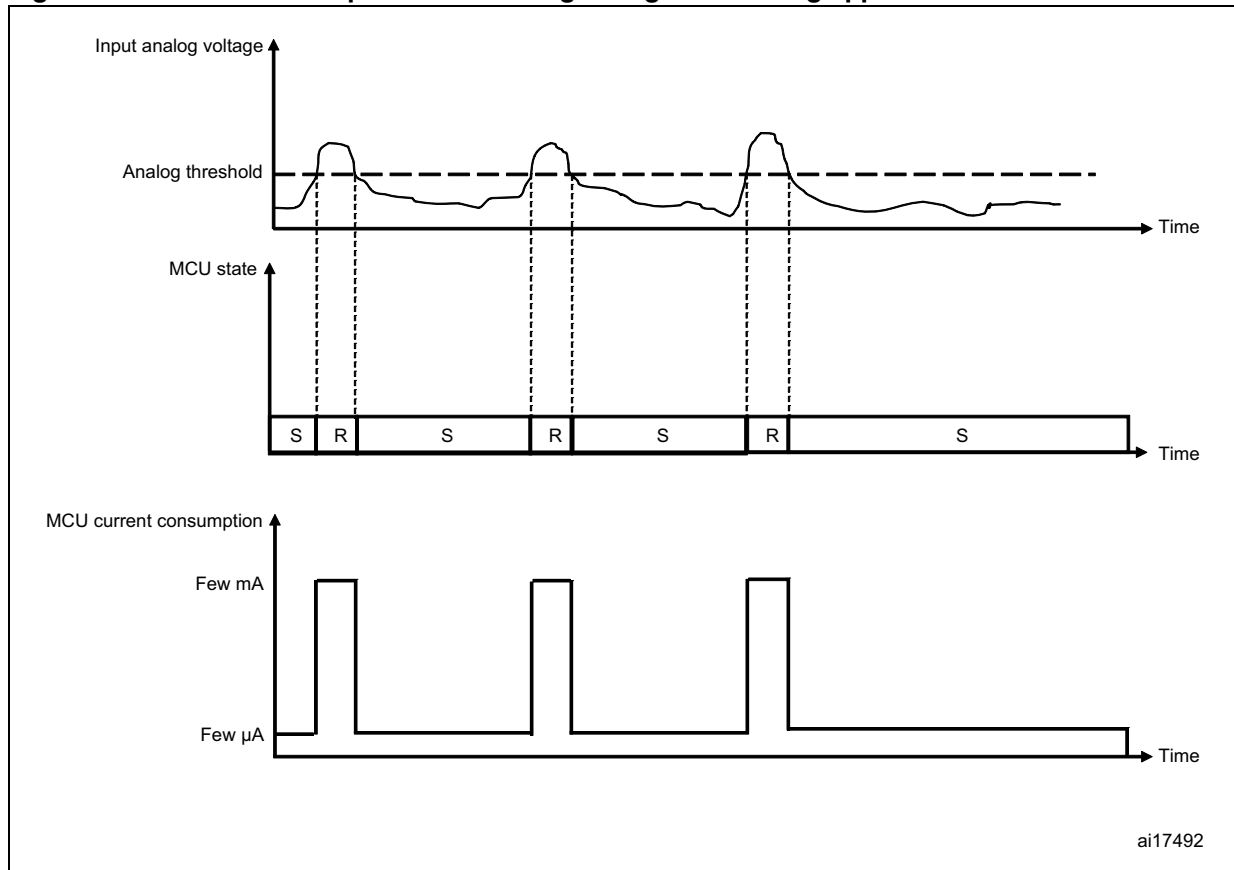

1. Legend for Figure 3  
S: Stop mode  
R: Run mode

The input analog voltage can be connected either to PB4 or PB5. The analog threshold can be provided internally through  $V_{REFINT}$  and its submultiples or via an external pin through PB3. DAC channel 1 and channel 2 (DAC\_OUT1 and DAC\_OUT2 respectively) cannot be used in such application cases since the DAC channels are powered off in Stop mode.

COMP2 wakes up the device from Stop mode through external interrupt line 22 (EXTI line 22).

Figure 4 shows the available configurations for inverting and non inverting inputs.

**Figure 4. COMP2 configuration**

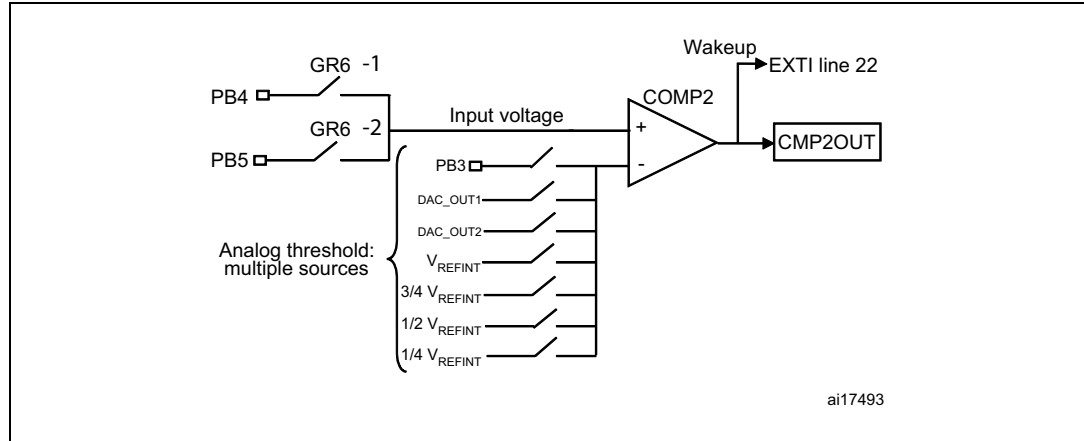

1. Legend for [Figure 4](#)  
 DAC\_OUT1: DAC channel 1 output  
 DAC\_OUT2: DAC channel 2 output  
 $V_{REFINT}$ : Internal reference voltage  
 COMP2OUT: Comparator 2 output (internal output)

When the device enters Stop mode, only COMP2 and the internal reference voltage,  $V_{REFINT}$ , remain powered on.

- Note:**
- 1 Refer to the device datasheet for power consumption values.
  - 2 In High-density devices, pins PB6 and PB7 can be used also as COMP2 non-inverting inputs.
  - 3 If the analog threshold corresponds to the internal reference voltage,  $V_{REFINT}$  (1.22 V), COMP1 can be used instead of COMP2 since it consumes much less power. In this case, the input analog voltage can be connected to any channel among the 24 ADC channels.

## 2 Analog watchdog during Stop mode

The ADC in the STM32L1 family can be used as an analog watchdog with programmable high and low thresholds. Nevertheless, the MCU must be kept in Run mode to be able to watch analog voltage on input since the ADC is powered off in Stop mode. For ultra low power STM32L1 devices, two analog comparators, COMP1 and COMP2, can be combined in window mode and used as an analog watchdog that remains powered on while the MCU is stopped. Consequently, lower consumption is achieved and power is saved.

**Figure 5** displays the configuration of two such analog comparators in window mode. Threshold1 is set to the internal reference voltage,  $V_{REFINT}$ , and threshold2 is configurable among  $V_{REFINT}$ ,  $3/4 V_{REFINT}$ ,  $1/2 V_{REFINT}$ ,  $3/4 V_{REFINT}$ ,  $DAC\_OUT1$ ,  $DAC\_OUT2$ , or the external pin PB3. The analog input voltage can be applied on group 6 of the analog switches (PB4 or PB5).

**Figure 5. Analog comparators combined in window mode**

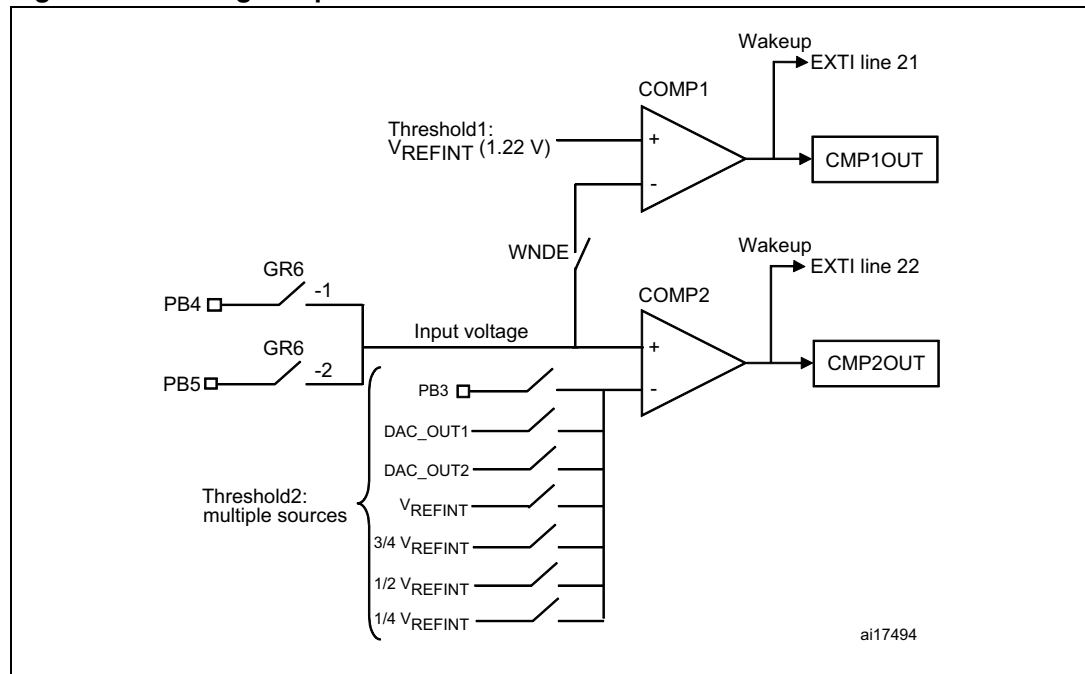

**Note:** In High-density devices, pins PB6 and PB7 can be used also as COMP2 non-inverting inputs.

$DAC\_OUT1$  and  $DAC\_OUT2$  cannot be used in Stop mode since the DAC peripheral is powered off.

In an analog watchdog application, COMP1 is configured through external interrupt line 21 (EXTI line 21) to exit the MCU from Stop mode when the analog input voltage exceeds  $V_{REFINT}$ . COMP2 is set, through EXTI line 22, to exit the MCU from Stop mode when the analog voltage goes below the lower threshold. Throughout the time the analog voltage is within the defined thresholds, the MCU is in Stop mode and power consumption is reduced.

When the analog voltage exceeds the defined thresholds, average power consumption can be reduced by switching to Run mode.

Figure 6 gives an overview of an analog watchdog application with threshold1 higher than threshold2.

**Figure 6. Analog watchdog during Stop mode**

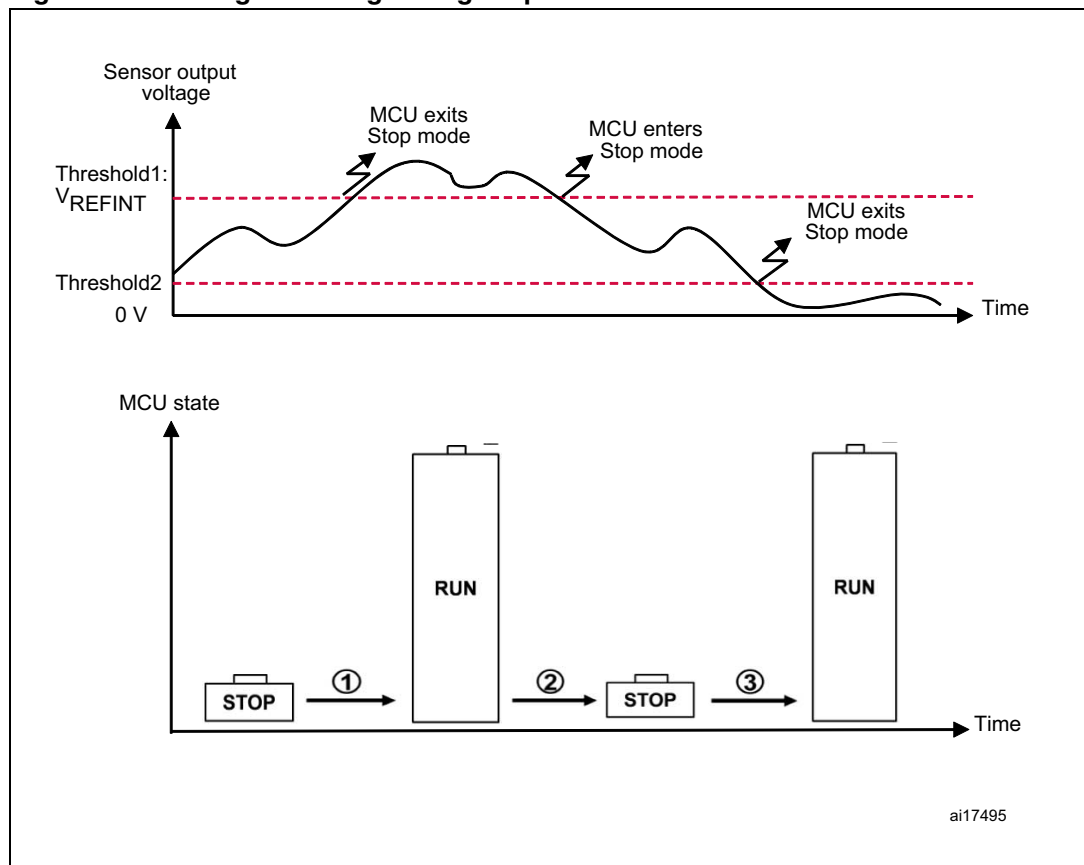

1. While the MCU is in Stop mode, the input voltage exceeds threshold1 and the MCU exits Stop mode.
2. While the MCU is in Run mode, the input voltage goes below threshold1 and the MCU enters Stop mode.
3. While the MCU is in Stop mode, the input voltage goes below threshold2 and the MCU exits Stop mode.

**Note:** 1 In Stop mode, only COMP1, COMP2 and  $V_{REFINT}$  continue to consume power. Please refer to the specific device datasheet for power consumption values.  
 2 No hysteresis is implemented on either comparator inputs.



### 3 Pulse width measurement

In STM32L1 devices, the COMP2 output can be redirected to the input capture of the embedded timers: TIM2, TIM3, TIM4, and TIM10. Redirecting the COMP2 output allows a signal width or frequency with specific low and high levels (for example, a shifted signal) to be measured. [Figure 7](#) displays all the possible output redirections of the COMP2 output.

The input signal, whose signal width should be measured, is connected to any I/O of analog switches group 6 (PB4 or PB5). The reference signal can be powered by:

- an internal reference ( $V_{REFINT}$ ,  $3/4 V_{REFINT}$ ,  $1/2 V_{REFINT}$ , or  $1/4 V_{REFINT}$ )
- the built-in DAC (channel 1 or channel 2)
- an external pin through PB3

The COMP2 output redirection is achieved through the OUTSEL[2:0] bits.

The timer input capture channel is configured to save the timer counter at both rising and falling edges. When the input signal goes above the reference voltage, COMP2 output is at a high level generating a rising edge on the timer input capture. When the input signal goes under the reference voltage, COMP2 output is at low level generating a falling edge. The elapsed time between the two consecutive events (falling then rising edge or rising then falling edge) represents the pulse width. Hence, the pulse width measurement is performed by simple subtraction of the counter values. [Figure 8](#) gives an overview of the pulse width measurement as measured by COMP2.

**Figure 7. COMP2 with output redirection feature**

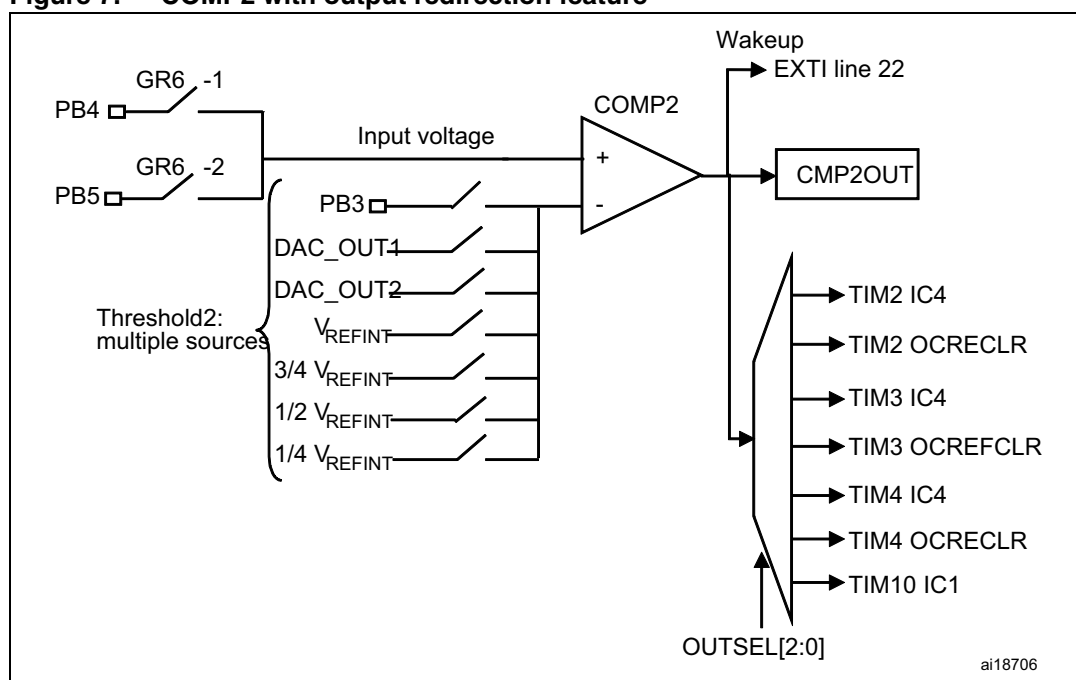

- Legend for [Figure 7](#)  
 DAC\_OUT1: DAC channel 1 output  
 DAC\_OUT2: DAC channel 2 output  
 $V_{REFINT}$ : Internal reference voltage  
 COMP2OUT: Comparator 2 output (internal output)  
 TIMx ICy: Timer x input capture channel y  
 TIMx OCRECLR: Timer x output compare reference clear

**Note:** In High-density devices, pins PB6 and PB7 can be used also as COMP2 non-inverting inputs.

Figure 8. Pulse width measurement: COMP2 output redirection to timer

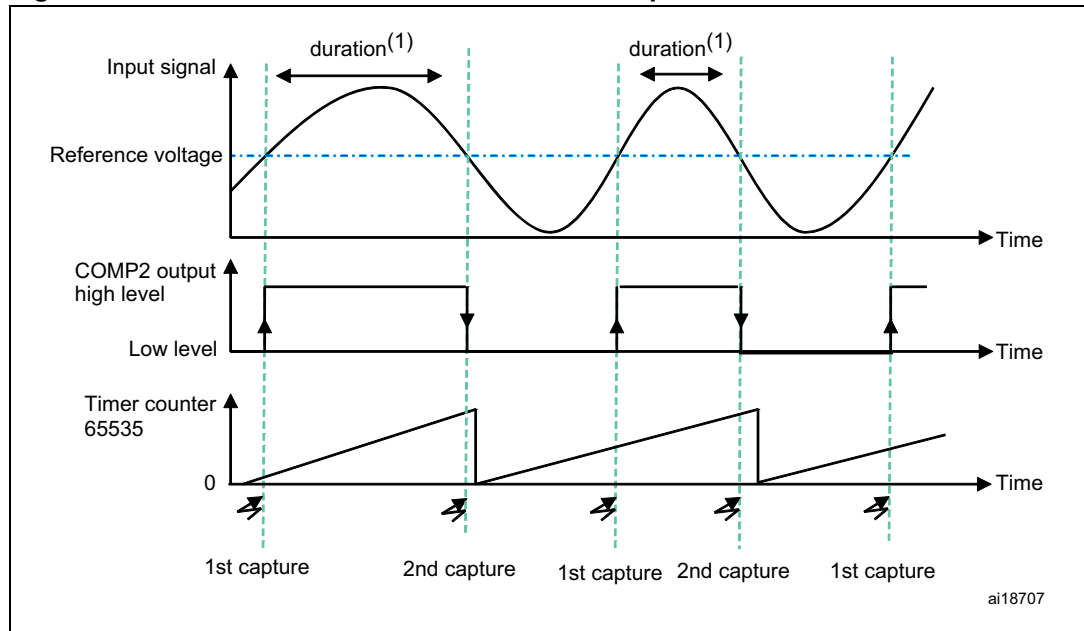

1. The duration that should be measured
2. In the pulse width measurement application, COMP1 cannot be used since its output CMP1OUT (internal output) is not connected to the embedded timers.

Note: 1 Signal frequency can be achieved by configuring the timer input capture channel to save the counter value on only a rising or falling edge.

2 DAC outputs (DAC\_OUT1 or DAC\_OUT2) can be used as inverting inputs to allow the reference voltage level (threshold) to be internally provided and programmable by software from 0 V to  $V_{DD}$ .

## 4 PWM signal control

In STM32L1 devices, the COMP2 output can be redirected to the output compare reference clear signal (OCREFCLR) of the embedded timers: TIM2, TIM3, and TIM4 (refer to [Figure 7: COMP2 with output redirection feature](#)). The possibility of redirecting the COMP2 output can be used to provide a fast response time that is independent from the system frequency when an analog event occurs. This application case controls a PWM signal for motor control when the current sensor output is connected to the COMP2 non-inverting input. In this situation, the reference voltage is connected to the COMP2 inverting input. When the current sensor output exceeds the selected threshold, the COMP2 output goes high and the PWM signals switch to safe state.

**Figure 9. PWM signal control: COMP2 output redirection to timer**

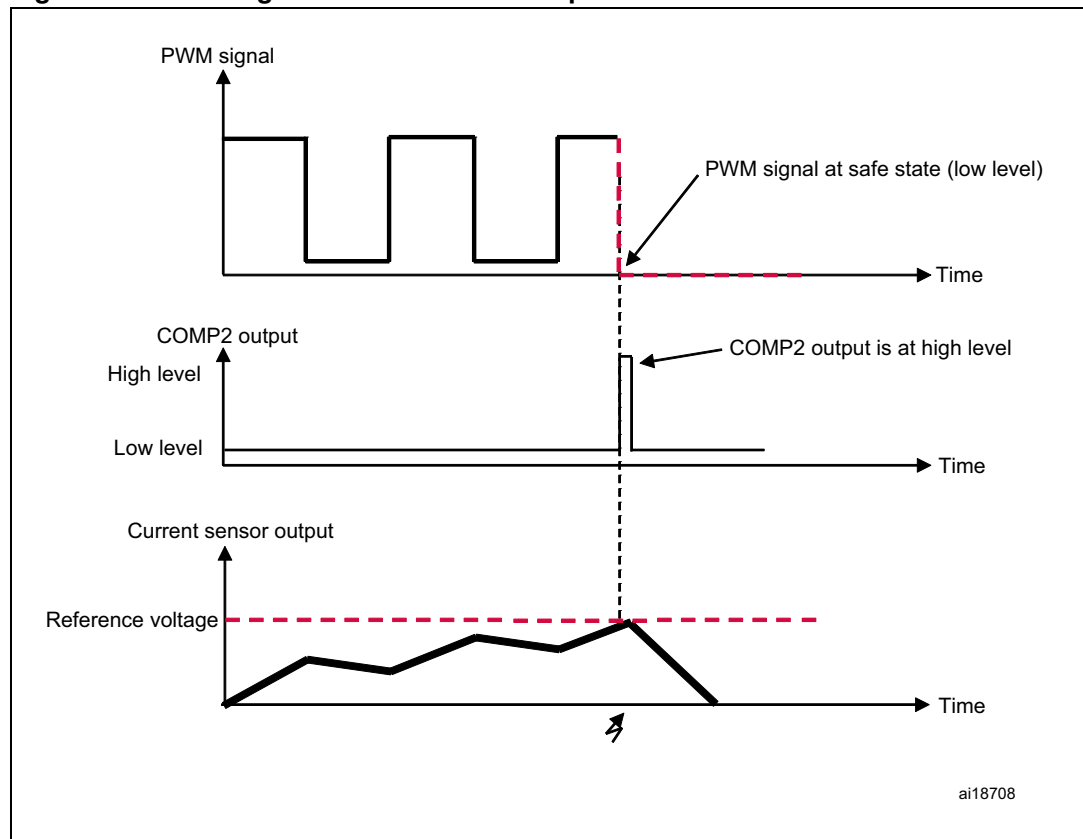

1. In the pulse width measurement application, COMP1 cannot be used since its output COMP1OUT (internal output) is not connected to the embedded timers.

**Note:** *When the current sensor voltage reaches the reference voltage, the COMP2 output goes high. Consequently, the PWM and output compare reference signals go low (to safe state).*

## 5 Capacitance measurement

The ability to connect the COMP2 output to the input capture channels of the timers allows the capacitance value to be measured. The principle is based on measuring the charge time of a resistor-capacitor (RC) network as follows:

- the charge time is measured
- the charge resistor (R) is already known
- the unknown capacitance (C) can be computed

*Figure 10* shows the hardware connection of the RC network to an STM32L1 device.

**Figure 10. RC network connection for capacitance measurement**

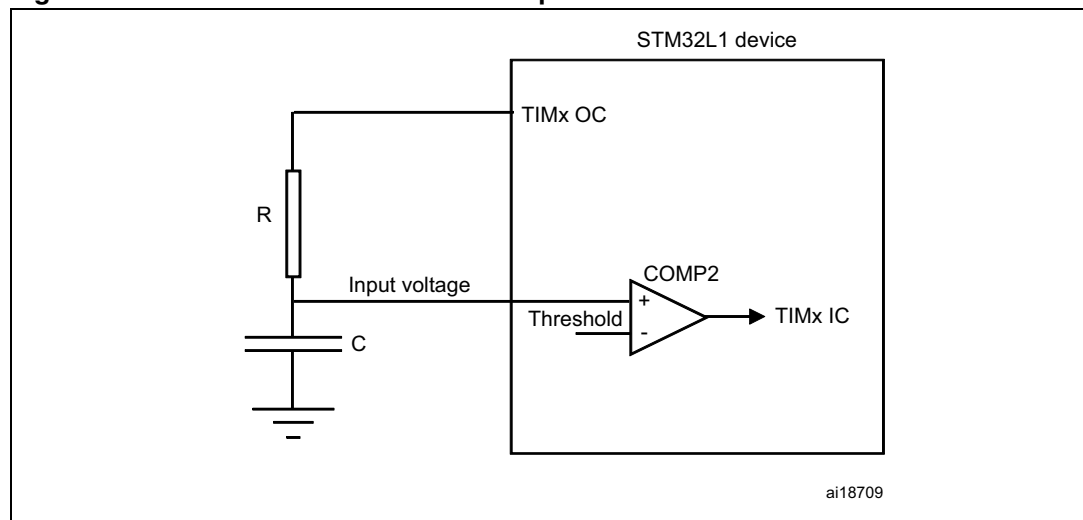

The capacitance measurement procedure consists of charging and discharging the capacitor through the resistor. The charge/discharge function follows an exponential curve.

The charge function is given by *Example 1*.

### Example 1

$$\text{Input voltage} = V_{DD}(1 - \exp(-t/T))$$

where:

- $V_{DD}$  is the positive supply voltage
- $t$  is the time
- $T$  is the RC constant

Charging and discharging the RC network is ensured by the timer output compare channel (TIMx OC) configured in PWM mode. The timer channel is connected to the resistor.

The input voltage is connected to the COMP2 non-inverting input while the threshold is connected to the COMP2 inverting input. When the input voltage crosses the threshold, the COMP2 output switches to high level and a capture event occurs saving the counter value.

*Figure 11* shows the capacitance measurement.

Figure 11. Capacitance measurement using COMP2

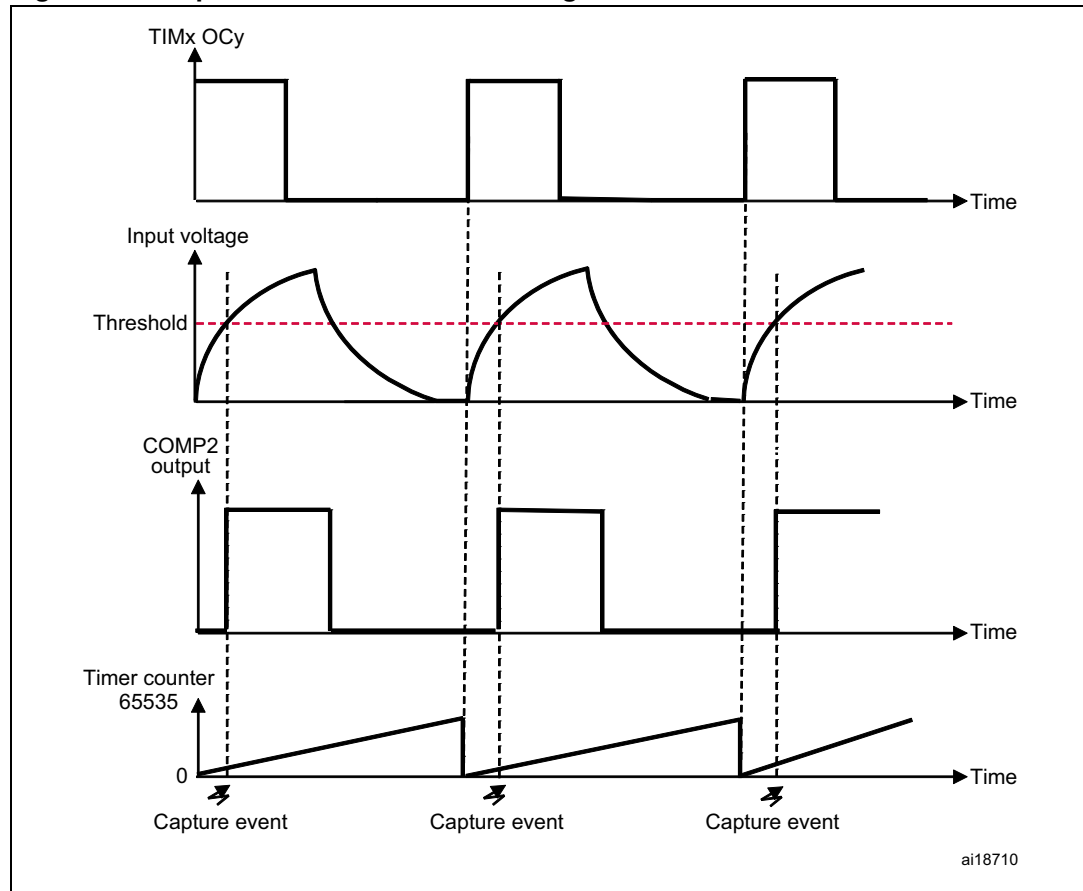

At the moment where the input voltage crosses the threshold and the COMP2 output switches to high level, the charge function is given by [Equation 1](#).

#### Equation 1

$$\text{Threshold} = V_{DD}(1 - \exp(-t_c / T))$$

where “ $t_c$ ” is the time when the input voltage crosses the threshold

Using [Equation 1](#) the capacitance value can be computed by [Equation 2](#).

#### Equation 2

$$C = -t / (R \times \ln(1 - \text{threshold} / (V_{DD})))$$

Usually  $R$ , the threshold, and  $V_{DD}$  are constant, so, measuring the capacitance is reduced to solving for [Equation 3](#).

#### Equation 3

$$C = -t / K$$

where  $K$  is solved using [Equation 4](#)

#### Equation 4

$$K = R \times \ln(1 - \text{threshold} / (V_{DD}))$$

## 6 Brightness control using a light dependent resistor (LDR)

In some battery operated applications, the microcontroller needs to be powered if the environment is lit; otherwise, it must be kept powered-off. For such applications, a light dependent resistor (LDR), whose resistance depends on light intensity, is useful to control the microcontroller state. Using an LDR sensor, the microcontroller can switch to/from Low-power mode depending on the voltage provided by the LDR resistor. *Figure 12* shows how to connect an LDR resistor to an STM32L1 device. COMP2 non-inverting input can be connected to an LDR resistor through a voltage divider ( $V_{IN}$ ). The threshold can be set externally to PB3 or set internally to  $V_{REFINT}$ ,  $3/4 V_{REFINT}$ ,  $1/2 V_{REFINT}$ , or  $1/4 V_{REFINT}$ . The COMP2 output (CMP2OUT) can be internally connected to EXTI line 22 which, when configured to detect both rising and falling edges on CMP2OUT, can be used as an interrupt source to switch to/from Low power mode.

**Figure 12. Connecting an LDR resistor to an STM32L1 device**

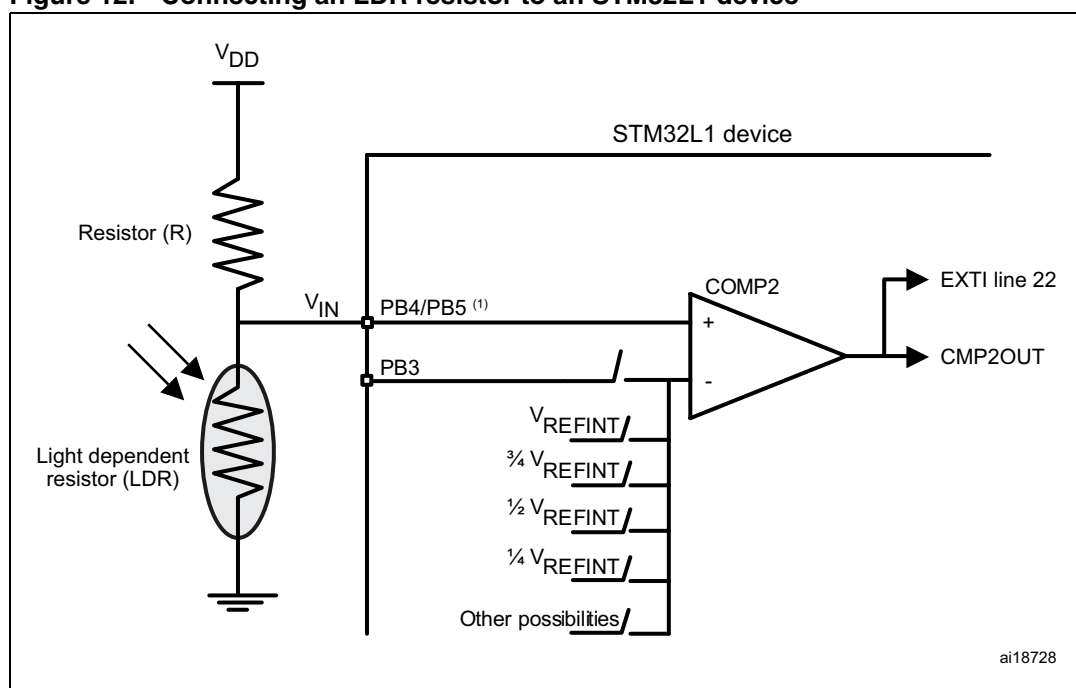

1. PB4 or PB5 can be used as COMP2 non-inverting input. Thus,  $V_{IN}$  can be connected to PB4 or PB5. The voltage  $V_{IN}$  can be computed using *Equation 5*.

**Equation 5**

$$V_{IN} = \frac{LDR}{(LDR + R)} \times V_{DD}$$

As the LDR resistance decreases with increasing light intensity, the voltage  $V_{IN}$  decreases as more light shines on the LDR.

The top part of [Figure 13](#) shows the evolution of  $V_{IN}$  as a function of light variation. The selected threshold (COMP2 inverting input) defines the limit of dark/light. The bottom part of [Figure 13](#) shows that COMP2 output (CMP2OUT) level depends on  $V_{IN}$  and consequently on light intensity. Using EXT1 line 22 (which is internally connected to CMP2OUT), the microcontroller can detect the CMP2OUT level switch (from a high level to a low level or *vice versa*).

**Figure 13. Comparator output behavior versus light intensity**

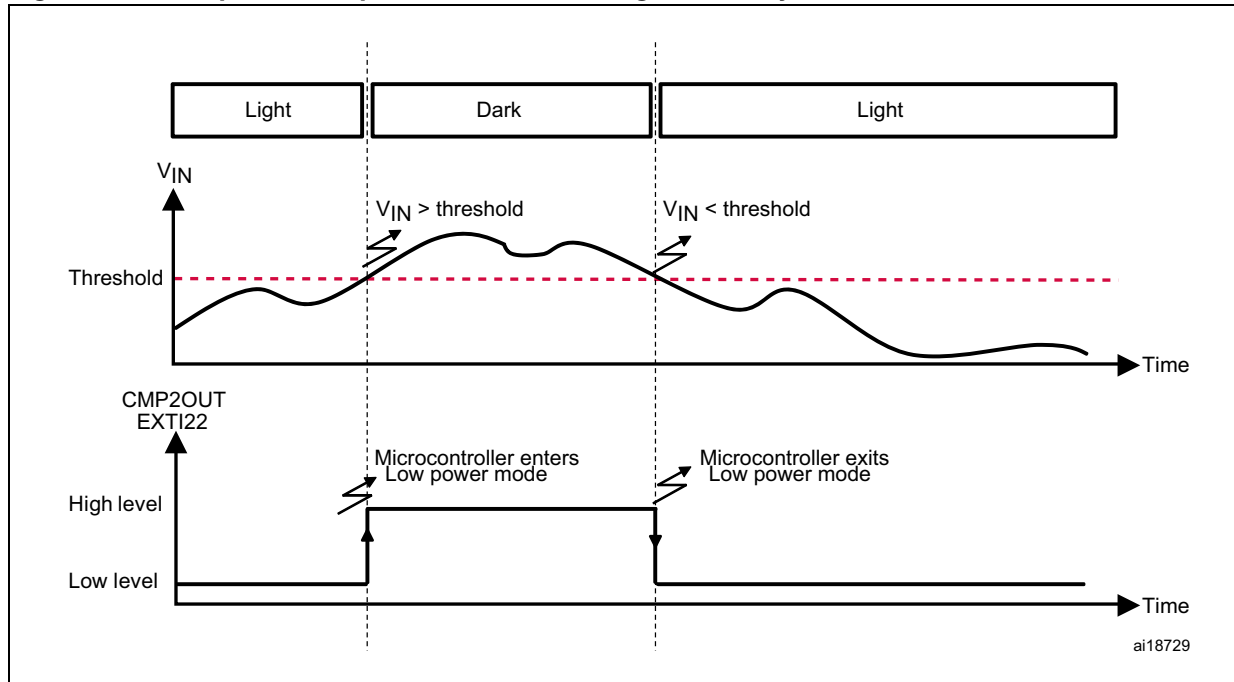

The LDR resistor can be used in other microcontroller-based applications rather than darkness control (for example: DC relay control and AutoFocus).

For other uses of analog comparators using LDR resistors, refer to the STM32L152-EVAL (for STM32L1xx Ultra Low Power Medium-density devices) or to STM32L152D-EVAL (for STM32L1xx Ultra Low Power High-density devices) demonstration firmware. In this demonstration, the LCD glass contrast is adjusted according to the luminosity detected using the LDR resistor.

## 7 Revision history

**Table 1. Document revision history**

Date	Revision	Changes
10-Jan-2011	1	Initial release.
12-Jan-2012	2	Document updated to include Ultra Low Power High-density device features.
07-Feb-2012	3	Updated notes under <a href="#">Figure 4: COMP2 configuration</a> , <a href="#">Figure 5: Analog comparators combined in window mode</a> and <a href="#">Figure 7: COMP2 with output redirection feature</a> .



**Please Read Carefully:**

Information in this document is provided solely in connection with ST products. STMicroelectronics NV and its subsidiaries ("ST") reserve the right to make changes, corrections, modifications or improvements, to this document, and the products and services described herein at any time, without notice.

All ST products are sold pursuant to ST's terms and conditions of sale.

Purchasers are solely responsible for the choice, selection and use of the ST products and services described herein, and ST assumes no liability whatsoever relating to the choice, selection or use of the ST products and services described herein.

No license, express or implied, by estoppel or otherwise, to any intellectual property rights is granted under this document. If any part of this document refers to any third party products or services it shall not be deemed a license grant by ST for the use of such third party products or services, or any intellectual property contained therein or considered as a warranty covering the use in any manner whatsoever of such third party products or services or any intellectual property contained therein.

**UNLESS OTHERWISE SET FORTH IN ST'S TERMS AND CONDITIONS OF SALE ST DISCLAIMS ANY EXPRESS OR IMPLIED WARRANTY WITH RESPECT TO THE USE AND/OR SALE OF ST PRODUCTS INCLUDING WITHOUT LIMITATION IMPLIED WARRANTIES OF MERCHANTABILITY, FITNESS FOR A PARTICULAR PURPOSE (AND THEIR EQUIVALENTS UNDER THE LAWS OF ANY JURISDICTION), OR INFRINGEMENT OF ANY PATENT, COPYRIGHT OR OTHER INTELLECTUAL PROPERTY RIGHT.**

**UNLESS EXPRESSLY APPROVED IN WRITING BY TWO AUTHORIZED ST REPRESENTATIVES, ST PRODUCTS ARE NOT RECOMMENDED, AUTHORIZED OR WARRANTED FOR USE IN MILITARY, AIR CRAFT, SPACE, LIFE SAVING, OR LIFE SUSTAINING APPLICATIONS, NOR IN PRODUCTS OR SYSTEMS WHERE FAILURE OR MALFUNCTION MAY RESULT IN PERSONAL INJURY, DEATH, OR SEVERE PROPERTY OR ENVIRONMENTAL DAMAGE. ST PRODUCTS WHICH ARE NOT SPECIFIED AS "AUTOMOTIVE GRADE" MAY ONLY BE USED IN AUTOMOTIVE APPLICATIONS AT USER'S OWN RISK.**

Resale of ST products with provisions different from the statements and/or technical features set forth in this document shall immediately void any warranty granted by ST for the ST product or service described herein and shall not create or extend in any manner whatsoever, any liability of ST.

ST and the ST logo are trademarks or registered trademarks of ST in various countries.

Information in this document supersedes and replaces all information previously supplied.

The ST logo is a registered trademark of STMicroelectronics. All other names are the property of their respective owners.

© 2012 STMicroelectronics - All rights reserved

STMicroelectronics group of companies

Australia - Belgium - Brazil - Canada - China - Czech Republic - Finland - France - Germany - Hong Kong - India - Israel - Italy - Japan - Malaysia - Malta - Morocco - Philippines - Singapore - Spain - Sweden - Switzerland - United Kingdom - United States of America

[www.st.com](http://www.st.com)