**M24LR series internal capacitance considerations
for antenna tuning**

1 Introduction

The datasheet of the M24LR series devices^(a) specifies a typical internal tuning capacitance value of 27.5 pF measured at 0.5 V_{PEAK}. While this value is correct in production test conditions, more considerations have to be taken into account for tuning the antenna in a real application environment. This document describes the M24LR series tuning capacitance variation as a function of input voltage, explains the M24LR series tuning capacitance specification and gives a robust tuning capacitance target for the inductive loop antenna design.

Table 1: Applicable products

Type	Applicable products
Dual Interface EEPROM	M24LR series ⁽¹⁾

1. While the considerations introduced in this document applies to the entire M24LR series, the M24LR64-R has been used hereafter for specific measurements purpose.

a. I²C/ISO15693 Dual Interface EEPROM IC

2 Tuning capacitance variation as a function of input voltage

Figure 1 shows an example measurement of the M24LR serial equivalent capacitance as a function of the $V_{AC0-AC1}$ input RF voltage. The capacitance is measured between $0.2 V_{PEAK}$ and $2 V_{PEAK}$ at 13.56 MHz using a network analyzer.

Figure 1. M24LR64-R serial equivalent capacitance C_S measurement example

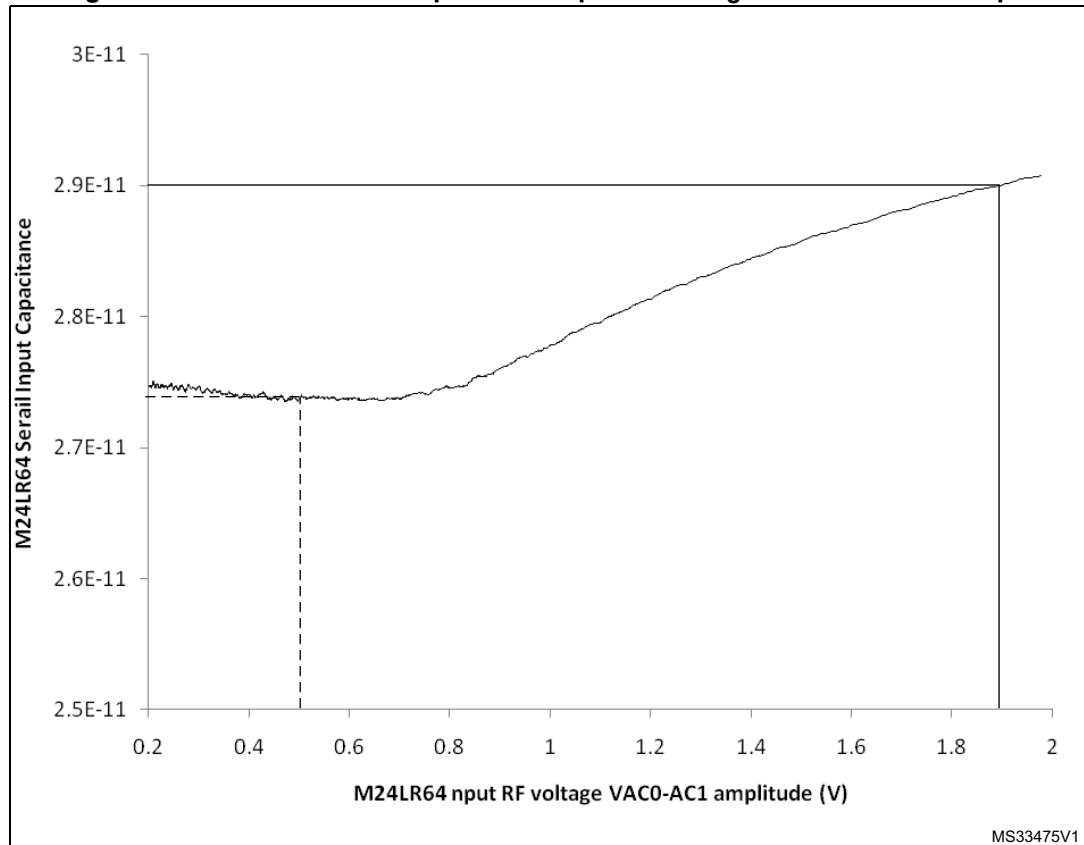

The dotted line in Figure 1 corresponds to the voltage level (0.5 V) at which the serial capacitance (C_S) of the M24LR series is measured in production and specified in the datasheet (27.5 pF).

This voltage level has been chosen on the plateau of the capacitance curve to ensure the best measurement repeatability.

3 M24LR series capacitance for antenna tuning

3.1 M24LR series equivalent schematic

Figure 2 shows the equivalent circuit of an M24LR mounted on a loop antenna, in the presence of a magnetic field.

Figure 2. M24LR equivalent circuit

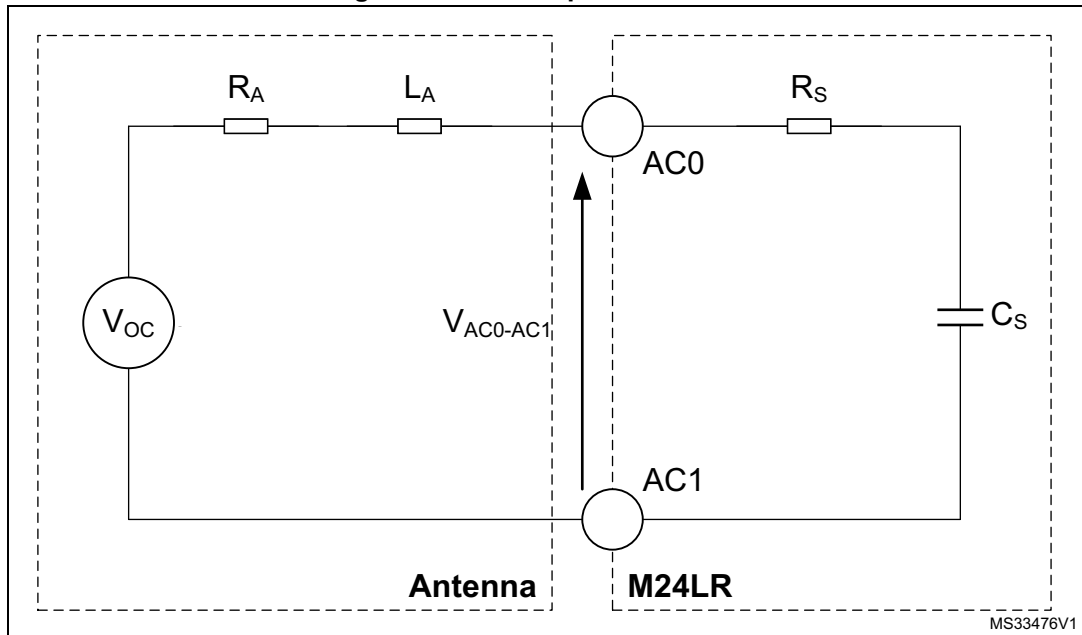

V_{OC} represents the open circuit voltage available from the antenna. When a sinusoidal magnetic field (H) flows through the M24LR antenna, the open circuit voltage amplitude (V_{OC}) can be determined using the following equation.

Equation 1

$$V_{OC} = N \cdot S \cdot \mu \cdot h \cdot \omega$$

In this equation, N and S are respectively the number of turns and the surface of the M24LR antenna, μ is the magnetic permeability of air, H is the magnetic field amplitude, and $\omega = 2 \cdot \pi \cdot f$ ($f = 13.56$ MHz).

R_A and L_A represent respectively the resistive part and inductive part of the antenna impedance. R_S and C_S represent the serial equivalent model of the M24LR impedance.

The voltage amplitude ($V_{AC0-AC1}$) available on the M24LR coil pads AC0 and AC1 can be determined using the following equation.

Equation 2

$$V_{AC0-AC1} = V_{OC} \left| \frac{Z_S}{Z_A + Z_S} \right|$$

In this equation, Z_S is the complex serial impedance of the M24LR. $Z_S = R_S + j \cdot X_S$ and $X_S = -1/(C_S \cdot \omega)$.

As a image of the M24LR power consumption, R_S is a function of $V_{AC0-AC1}$. The variation of C_S as a function of $V_{AC0-AC1}$ is shown at low power by the curve in [Figure 1](#).

In the presence of a sinusoidal time varying magnetic field, the voltage $V_{AC0-AC1}$ available across the M24LR antenna pads depends on Equations 1, 2 and the variation of C_S and R_S as a function of $V_{AC0-AC1}$.

Optimizing antenna tuning consists in designing an antenna with the correct impedance for the correct tuning capacitance.

Considering variations of C_S according to $V_{AC0-AC1}$, the correct capacitance value used as reference for antenna design must be defined.

Please refer to AN2972 “Designing an antenna for the M24LRxx-R and M24LRxxE-R dual interface I²C/RFID devices” for more details on antenna tuning criteria and methodology.

3.2 Correct M24LR series capacitance value for antenna tuning

According to [Equation 1](#), V_{OC} depends on the antenna dimensions, number of turns and the magnetic field amplitude flowing into the antenna.

As a consequence, for a given antenna, V_{OC} increases when the distance between the M24LR antenna and the reader antenna decreases (because the magnetic field increases).

[Figure 3](#) represents the M24LR input voltage variation as a function of V_{OC} for an antenna tuned on a M24LR serial capacitance value based on the curve shown in [Figure 1](#). As explained above, this case corresponds to a decreasing distance between M24LR antenna and reader antenna; the longer the distance from the reader antenna, the closer the value of V_{OC} gets to 0 V .

Figure 3. M24LR RF voltage

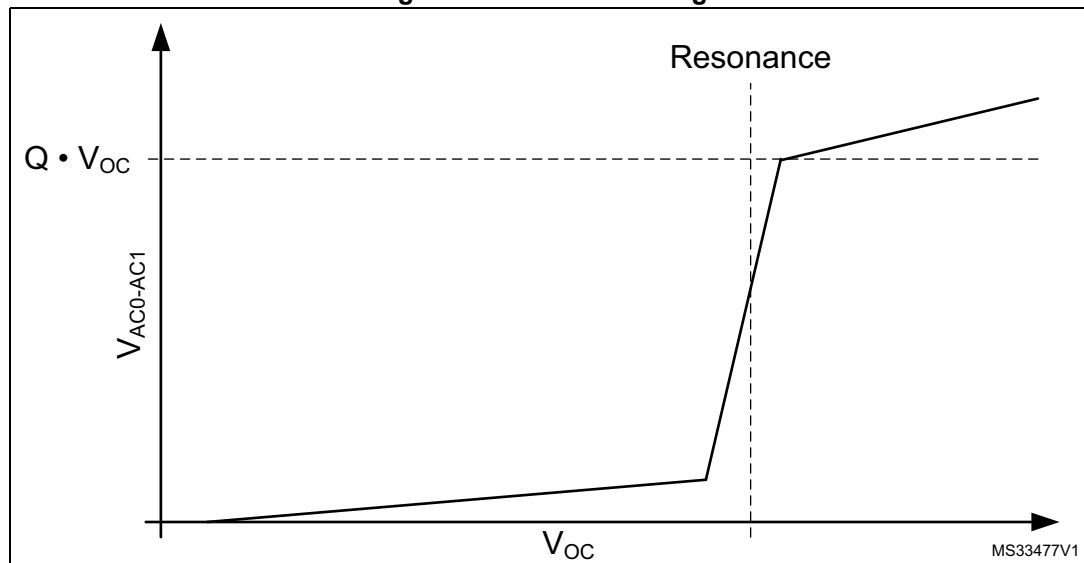

As V_{OC} increases, a sharp increase of $V_{AC0-AC1}$ occurs when the serial capacitance of the M24LR reaches a value that satisfies the resonance condition $L_A \cdot C_S \cdot \omega^2 = 1$. At resonance, $V_{AC0-AC1} = Q \cdot V_{OC}$ where $Q = R_S / (R_A + R_S) \cdot 1 / (R_S \cdot C_S \cdot \omega)$.

As an example, the Q value for the ANT1 reference design is between 30 and 35.

The maximum operating distance from the reader is defined by the maximum distance for which the M24LR input RF voltage $V_{AC0-AC1}$ remains above $1.9 V_{PEAK}$ which is the minimum voltage for the M24LR to be properly energized and perform read and write operations. Optimizing an antenna for an operating range consists in designing an antenna allowing $V_{AC0-AC1} \geq 1.9 V_{PEAK}$ at the largest distance from reader.

To satisfy this condition, antenna inductance must satisfy the resonance criteria $L_A \cdot C_S \cdot \omega^2 = 1$, where C_S is the M24LR serial capacitance measured at the minimum operating voltage $1.9 V_{PEAK}$ (as shown in *Figure 1*, where C_S is close to 29 pF at $1.9 V_{PEAK}$).

To demonstrate this, *Figure 4* represents the M24LR RF Input voltage $V_{AC0-AC1}$ as a function of the RF voltage V_{OC} available from the antenna for different inductive loop antennas tuned respectively for $C_{S1} < C_{S2}$, $C_{S2} = 29 \text{ pF}$ and $C_{S3} > C_{S2}$.

The comparison graphics shown in *Figure 4* assume using the same antenna dimensions and number of turns.

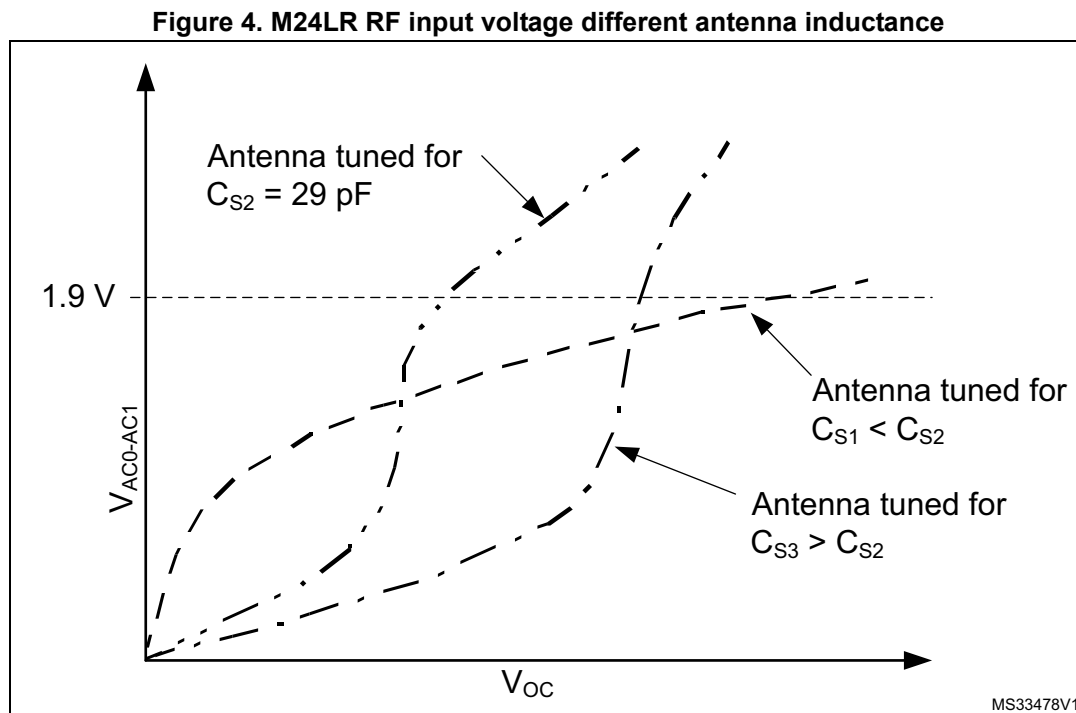

As shown in *Figure 4*, the minimum RF voltage V_{OC} for which $V_{AC0-AC1}$ is above $1.9 V_{PEAK}$ (and consequently maximum distance at which the M24LR can operate) is reached for an antenna inductance L_A designed for $C_S = 29 \text{ pF}$.

4 Conclusion

Taking into account this information, STMicroelectronics recommends designing antennas for the M24LR series using $C_S = 29 \text{ pF}$ as a reference value, instead of the value specified in the datasheet which corresponds to production test conditions.

5 Revision history

Table 2. Document revision history

Date	Revision	Changes
23-Jul-2010	1	Initial release.
13-Dec-2013	2	Extended the scope of this application note to the entire M24LR series.

Please Read Carefully:

Information in this document is provided solely in connection with ST products. STMicroelectronics NV and its subsidiaries (“ST”) reserve the right to make changes, corrections, modifications or improvements, to this document, and the products and services described herein at any time, without notice.

All ST products are sold pursuant to ST’s terms and conditions of sale.

Purchasers are solely responsible for the choice, selection and use of the ST products and services described herein, and ST assumes no liability whatsoever relating to the choice, selection or use of the ST products and services described herein.

No license, express or implied, by estoppel or otherwise, to any intellectual property rights is granted under this document. If any part of this document refers to any third party products or services it shall not be deemed a license grant by ST for the use of such third party products or services, or any intellectual property contained therein or considered as a warranty covering the use in any manner whatsoever of such third party products or services or any intellectual property contained therein.

UNLESS OTHERWISE SET FORTH IN ST’S TERMS AND CONDITIONS OF SALE ST DISCLAIMS ANY EXPRESS OR IMPLIED WARRANTY WITH RESPECT TO THE USE AND/OR SALE OF ST PRODUCTS INCLUDING WITHOUT LIMITATION IMPLIED WARRANTIES OF MERCHANTABILITY, FITNESS FOR A PARTICULAR PURPOSE (AND THEIR EQUIVALENTS UNDER THE LAWS OF ANY JURISDICTION), OR INFRINGEMENT OF ANY PATENT, COPYRIGHT OR OTHER INTELLECTUAL PROPERTY RIGHT.

ST PRODUCTS ARE NOT DESIGNED OR AUTHORIZED FOR USE IN: (A) SAFETY CRITICAL APPLICATIONS SUCH AS LIFE SUPPORTING, ACTIVE IMPLANTED DEVICES OR SYSTEMS WITH PRODUCT FUNCTIONAL SAFETY REQUIREMENTS; (B) AERONAUTIC APPLICATIONS; (C) AUTOMOTIVE APPLICATIONS OR ENVIRONMENTS, AND/OR (D) AEROSPACE APPLICATIONS OR ENVIRONMENTS. WHERE ST PRODUCTS ARE NOT DESIGNED FOR SUCH USE, THE PURCHASER SHALL USE PRODUCTS AT PURCHASER’S SOLE RISK, EVEN IF ST HAS BEEN INFORMED IN WRITING OF SUCH USAGE, UNLESS A PRODUCT IS EXPRESSLY DESIGNATED BY ST AS BEING INTENDED FOR “AUTOMOTIVE, AUTOMOTIVE SAFETY OR MEDICAL” INDUSTRY DOMAINS ACCORDING TO ST PRODUCT DESIGN SPECIFICATIONS. PRODUCTS FORMALLY ESCC, QML OR JAN QUALIFIED ARE DEEMED SUITABLE FOR USE IN AEROSPACE BY THE CORRESPONDING GOVERNMENTAL AGENCY.

Resale of ST products with provisions different from the statements and/or technical features set forth in this document shall immediately void any warranty granted by ST for the ST product or service described herein and shall not create or extend in any manner whatsoever, any liability of ST.

ST and the ST logo are trademarks or registered trademarks of ST in various countries.

Information in this document supersedes and replaces all information previously supplied.

The ST logo is a registered trademark of STMicroelectronics. All other names are the property of their respective owners.

© 2013 STMicroelectronics - All rights reserved

STMicroelectronics group of companies

Australia - Belgium - Brazil - Canada - China - Czech Republic - Finland - France - Germany - Hong Kong - India - Israel - Italy - Japan - Malaysia - Malta - Morocco - Philippines - Singapore - Spain - Sweden - Switzerland - United Kingdom - United States of America

www.st.com

