

Introduction

This note describes digital ballast for 70 W HID lamps (sodium or metal halide) used in general lighting applications. The ballast is composed of a boost converter (power factor controller PFC) working in transition mode and an inverter composed of a half bridge that drives the lamp in low frequency square wave.

Both the half bridge and the PFC stage are managed by the ST7LITE49K2 that controls the L6382D5, activating all the power switches.

The tests have been conducted using a 70 W metal halide lamp. With test results some design criteria are given.

Figure 1. STEVAL-ILH004V1 image

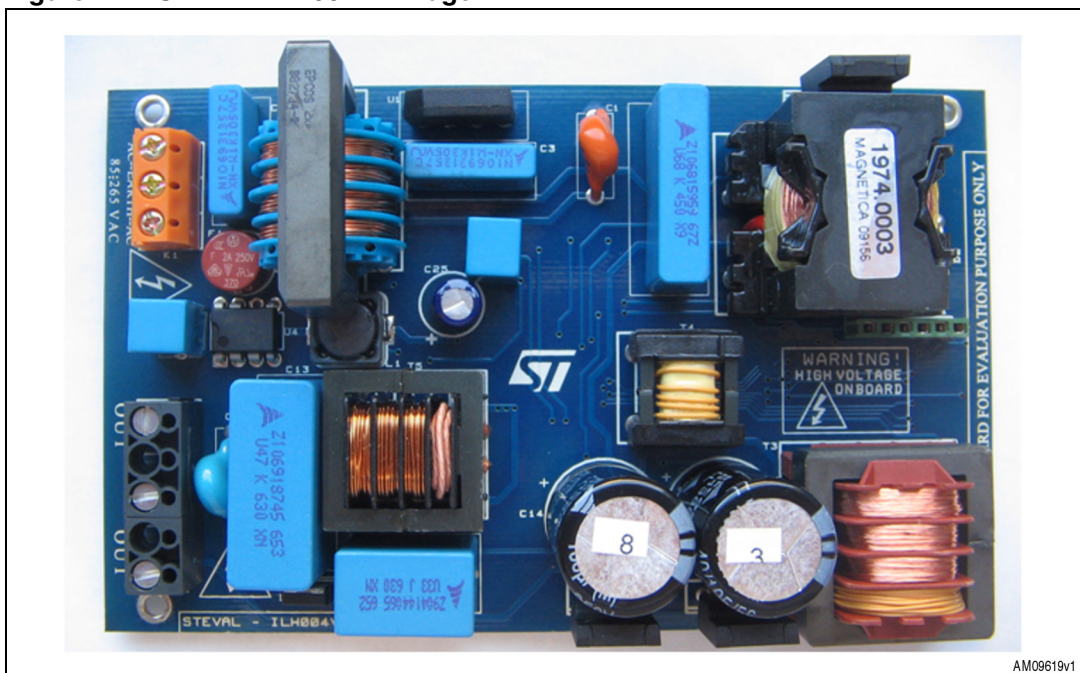

Contents

| | | |
|-----------|--|-----------|
| 1 | General circuit description | 5 |
| 2 | Lamp power calculation | 7 |
| 3 | STEVAL-ILH004V1: electrical scheme | 8 |
| 4 | STEVAL-ILH004V1: layout | 11 |
| 5 | STEVAL-ILH004V1: BOM list | 12 |
| 6 | PFC design rules | 16 |
| 6.1 | Specifications | 16 |
| 6.2 | Operating conditions | 16 |
| 6.3 | Power components | 17 |
| 6.3.1 | Input capacitor | 17 |
| 6.3.2 | Output capacitor | 17 |
| 6.3.3 | Boost inductor | 17 |
| 6.3.4 | Power MOSFET selection | 18 |
| 6.3.5 | Boost diode selection | 18 |
| 7 | Auxiliary power supply | 19 |
| 8 | ST7 microcontroller application pin use | 20 |
| 9 | Half bridge operation | 27 |
| 10 | Half bridge design criteria | 28 |
| 11 | Lamp operating point | 29 |
| 12 | STEVAL-ILH004V1: experimental results | 30 |
| 12.1 | Half bridge section | 30 |
| 12.2 | PFC section | 31 |
| 12.3 | Conducted emission pre-compliance tests | 33 |

13 Conclusion 34

14 Reference 35

15 Revision history 36

List of figures

| | | |
|------------|--|----|
| Figure 1. | STEVAL-ILH004V1 image | 1 |
| Figure 2. | 150 W HID ballast block diagram | 5 |
| Figure 3. | Inductor current during charge phase | 6 |
| Figure 4. | Inductor current during discharge phase | 6 |
| Figure 5. | PFC electric scheme | 8 |
| Figure 6. | Half bridge electric scheme | 9 |
| Figure 7. | Auxiliary power supply electric scheme and microcontroller pin use | 10 |
| Figure 8. | Bottom view (not to scale) | 11 |
| Figure 9. | Top view (not to scale) | 11 |
| Figure 10. | Auxiliary power supply | 19 |
| Figure 11. | ST7FLITE49K2 pinout | 20 |
| Figure 12. | Reset circuit | 21 |
| Figure 13. | PFC Vout sense. Resistor divider | 22 |
| Figure 14. | PFC Vlamp measurements. Resistor dividers | 22 |
| Figure 15. | Isense measurement circuit | 23 |
| Figure 16. | Half bridge ZCD circuitry | 24 |
| Figure 17. | Enable/disable igniter circuitry | 24 |
| Figure 18. | PFC ZCD circuitry | 25 |
| Figure 19. | PFC OC circuitry | 26 |
| Figure 20. | Steady-state phase: lamp current, voltage and lamp power | 30 |
| Figure 21. | Steady-state phase: inductor current and lamp voltage | 31 |
| Figure 22. | STEVAL-ILH004V1: power factor vs. input voltage | 31 |
| Figure 23. | STEVAL-ILH004V1: THD% vs. input voltage | 32 |
| Figure 24. | STEVAL-ILH004V1: efficiency% vs. input voltage | 32 |
| Figure 25. | STEVAL-ILH004V1: peak measurement | 33 |

1 General circuit description

The block diagram of the ballast is shown in [Figure 2](#). The complete circuit is composed of two stages:

- The boost converter which regulates the DC bus voltage and corrects the power factor.
- The inverter stage composed of a full bridge that converts the DC current coming from the PFC stage into an AC current for the lamp.

Operation mode of the full bridge realizes a buck converter. The full bridge, moreover, supplies the igniter block to generate the high voltage pulses.

Figure 2. 150 W HID ballast block diagram

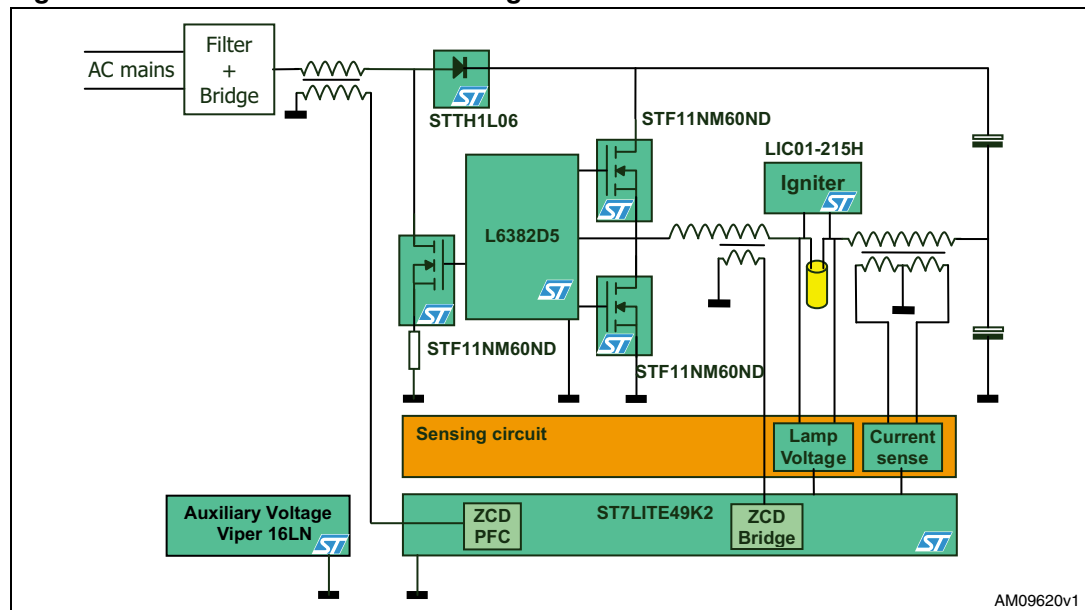

To generate a square wave current in the lamp, the circuit is driven in the following way:

When low-side PMOS Ls is switched ON, the current increase linearly, the voltage across the inductor L is:

Equation 1

$$V_L = V_{dc} - V_{lamp}$$

where:

- V_L = inductor voltage
- V_{dc} = DC bus voltage
- V_{lamp} = lamp voltage.

The duty cycle D is established by a current mode control circuit (see [Figure 3](#)).

Figure 3. Inductor current during charge phase

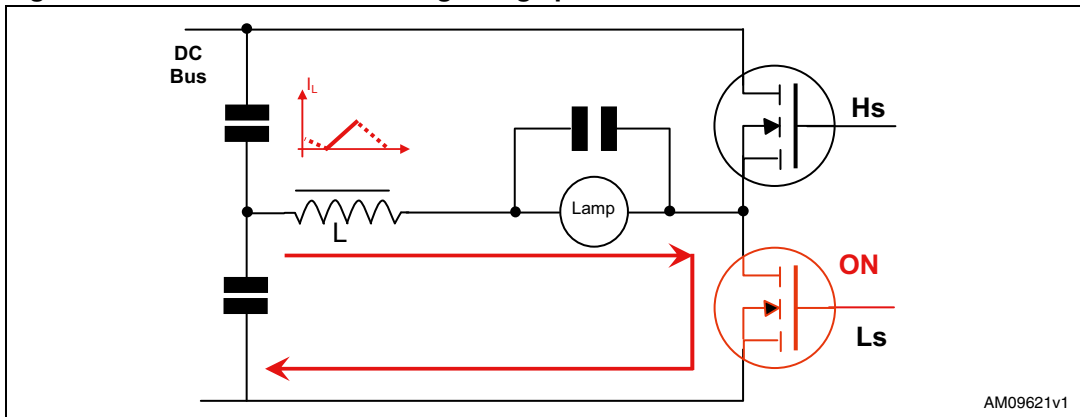

When the PMOS Ls is switched OFF, the current goes into freewheeling mode in the high-side device.

The voltage across the inductor is:

Equation 2

$$V_L = -V_{lamp}$$

The current through L in this phase decreases linearly. This circuit is actually a rectifier buck converter.

Figure 4. Inductor current during discharge phase

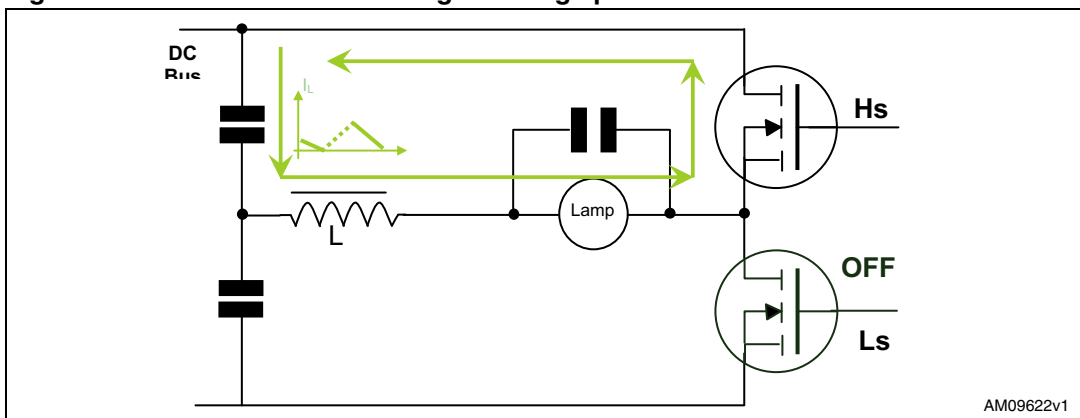

To invert the current in the lamp, the two PMOS work in a complementary way: Hs PMOS is driven and the freewheeling phase is in the Ls PMOS.

2 Lamp power calculation

The lamp power is obtained multiplying the lamp voltage signal for the lamp current.

The lamp voltage is sensed directly across the lamp and the lamp current is obtained by the relations reported below.

Starting from peak inductor and considering that the half bridge works in transition mode, the average value is:

Equation 3

$$I_{\text{lamp}} = I_{\text{AV}} = \frac{I_{\text{peak}}}{2} = \frac{\Delta I}{2}$$

where:

- I_{lamp} = lamp current
- I_{AV} = inductor average current
- I_{peak} = inductor peak current
- ΔI = inductor current ripple.

The inductor current is sensed with a current transformer and the output signal is proportional to the average value.

Considering that the inductor current is equal to lamp current, and the lamp voltage is directly measured by the MCU, in this way it is possible to calculate the lamp power simply multiplying the current for the lamp voltage:

Equation 4

$$P_{\text{lamp}} = V_{\text{lamp}} \times I_{\text{lamp}}$$

This relation is valid because the average current is equal to the lamp current. This formula is implemented in ST7 microcontrollers in order to calculate the lamp power.

Figure 6. Half bridge electric scheme

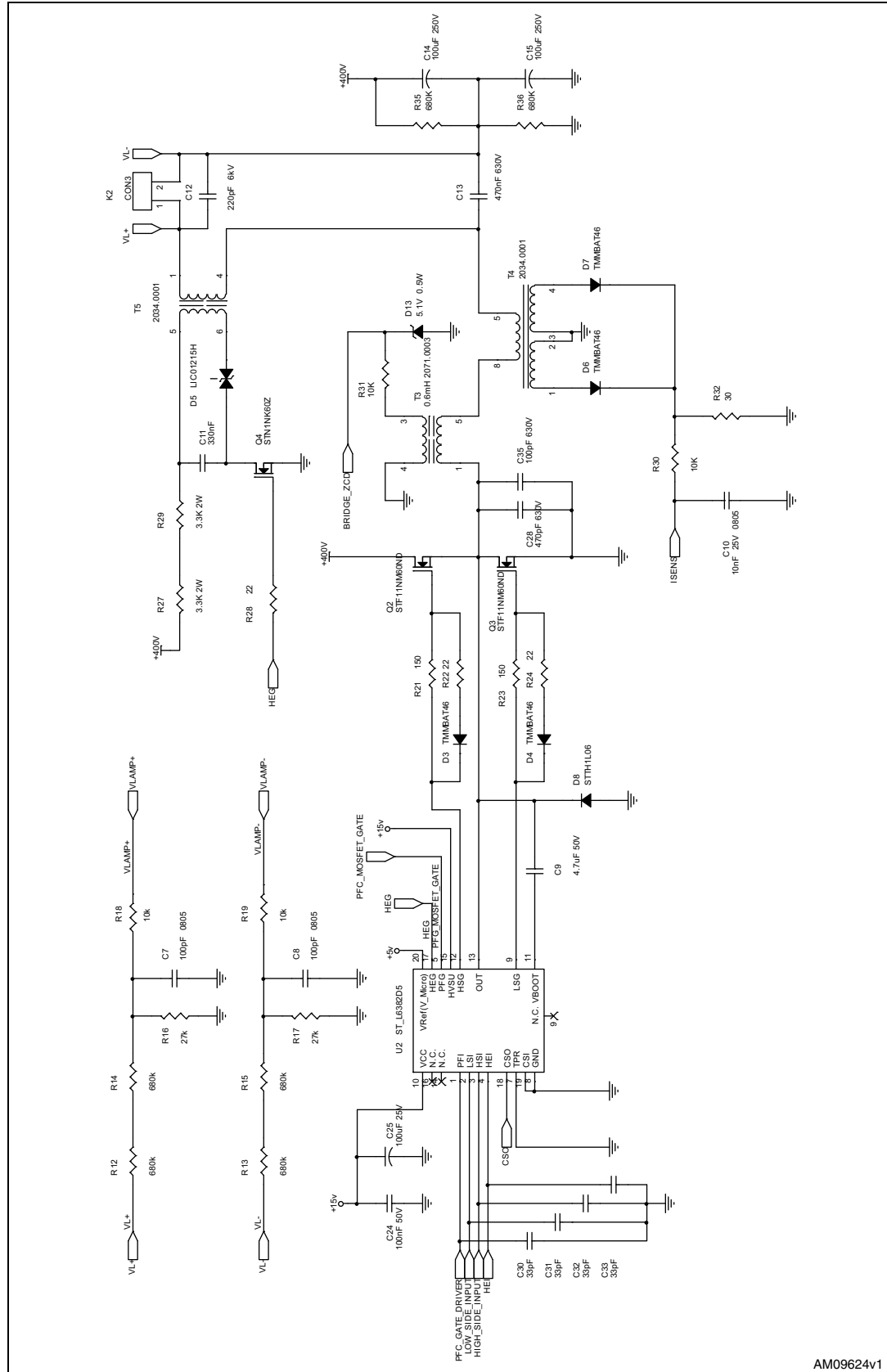

AM09624v1

4 STEVAL-ILH004V1: layout

Figure 8. Bottom view (not to scale)

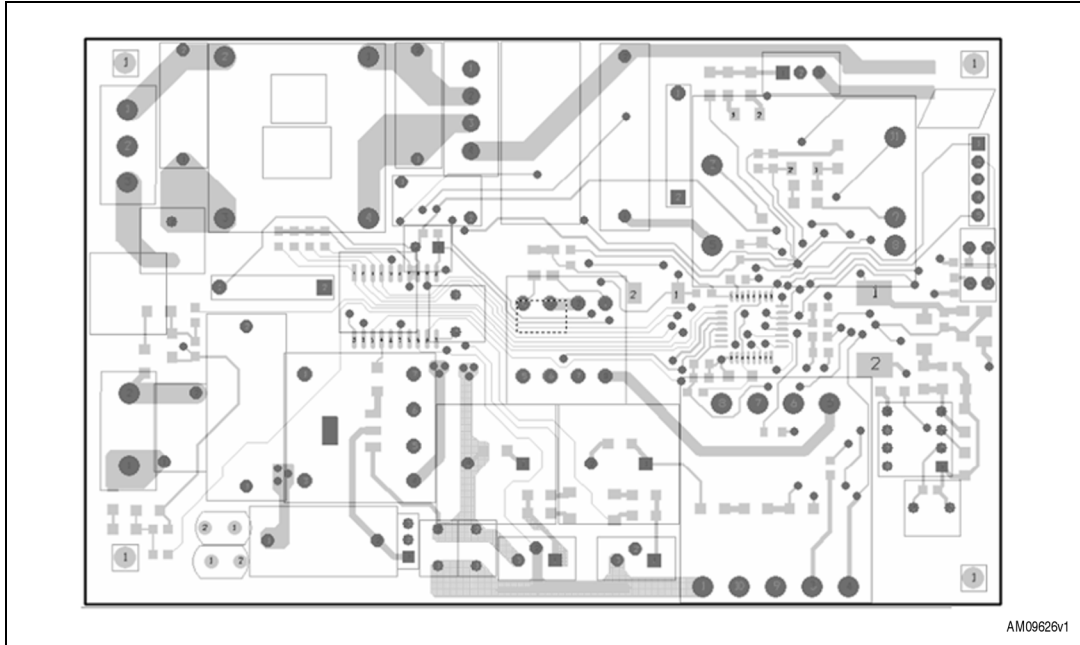
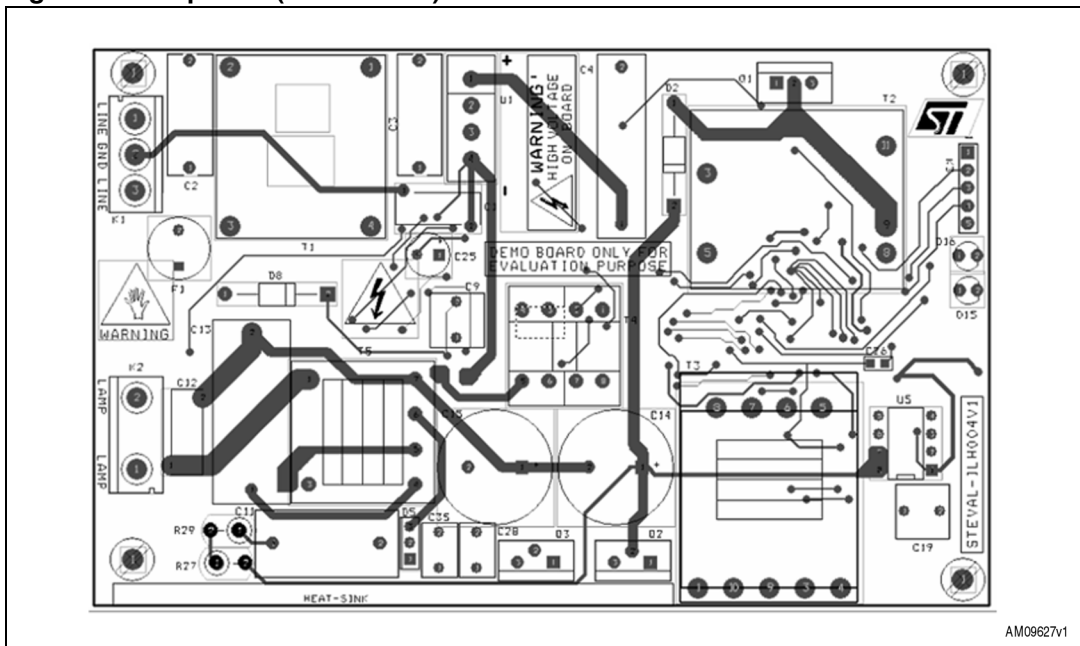

Figure 9. Top view (not to scale)





5 STEVAL-ILH004V1: BOM list

AN3372

Table 1. BOM

| Reference | Part / value | Tolerance% | Rating | Technology | Manufacturer |
|------------------------------|--------------|------------|--------------|----------------------------------|---------------------------|
| C1 | 1 nF | 20% | 250 Vac | Y1 suppression ceramic capacitor | |
| C2, C3 | 100 nF | 10% | 305 Vac | Polypropylene film capacitor X2 | TK-EPC B32922C3104K000 |
| C4 | 680 nF | 10% | 450 Vdc | Polypropylene film capacitor | TK-EPC B32673Z4684K000 |
| C5, C7, C8 | 100 pF | 10% | 25 V | X7R ceramic capacitor | |
| C6, C10, C27 | 10 nF | 10% | 25 V | X7R ceramic capacitor | |
| C9, C19 | 4.7 μ F | 20% | 63 V | Polyester film capacitor | TK-EPC B32529D0475M000 |
| C11 | 330 nF | 10% | 305 Vac | Polypropylene film capacitor | TK-EPC B32652A6334K000 |
| C12 | 220 pF | 10% | 6 kV/ 6.3 kV | High voltage ceramic capacitor | |
| C13 | 470 nF | 10% | 630 V | Polypropylene film capacitor | TK-EPC B32653A6474K000 |
| C14, C15 | 100 μ F | 20% | 250 V | Electrolytic aluminium capacitor | TK-EPC B43858H2107M000 |
| C16, C18, C21, C22, C23, C24 | 100 nF | 10% | 25 V | X7R ceramic capacitor | |
| C17 | 680 nF | 10% | 50 V | X7R ceramic capacitor | |
| C20 | 3.3 nF | 10% | 50 V | X7R ceramic capacitor | |
| C25 | 100 μ F | 20% | 35 V | Electrolytic aluminium capacitor | |
| C26, C30, C31, C32, C33, C34 | 33 pF | 10% | 25 V | X7R ceramic capacitor | |
| C29 | 10 μ F | 10% | 10 V | X7R/X5R ceramic capacitor | |

Doc ID 018625 Rev 1

12/37

STEVAL-ILH004V1: BOM list



Table 1. BOM (continued)

| Reference | Part / value | Tolerance% | Rating | Technology | Manufacturer |
|--------------------|----------------------|------------|--------------|----------------------------------|-----------------------------------|
| C28 | 470 pF 630 V | 5% | 630 V | Polypropylene film capacitor | |
| C35 | 100 pF 630 V | 5% | 630 V | Polypropylene film capacitor | |
| D1,D3,D4,D6,D7,D14 | TMMBAT46 | | 150 mA/100 V | Schottky diodes | STMicroelectronics |
| D2,D8 | STTH1L06 | | 1 A/600 V | Ultrafast high voltage rectifier | STMicroelectronics |
| D5 | LIC01-215H | | 215 V | Light ignition circuit | STMicroelectronics LIC01-215H |
| D10,D11 | STTH1R06A | | 1 A/600 V | Ultrafast high voltage rectifier | STMicroelectronics STTH1R06A |
| D12 | Zener diode | | 16 V | Zener diode | |
| D13 | Zener diode | | 5.1 V | Zener diode | |
| D15 | Green LED | | 2 mA | Green LED diode | |
| D16 | Red LED | | 2 mA | Red LED diode | |
| F1 | Fuse | | 2 A/250 V | | |
| K1 | Connector | | 16 A/250 Vac | | |
| K2 | Connector | | 16 A/250 Vac | | |
| L1 | 1 mH | | 340 mA | SMT inductor | TK-EPC B82464Z4105M000 |
| K3 | Programmer connector | | | 5 poles | |
| Q1,Q2,Q3 | STF11NM60ND | | 10 A/600 V | MDMESH™ II | STMicroelectronics STF11NM60ND |
| Q4 | STN1NK60Z | | 1 A/600 V | SUPERMESH™ | STMicroelectronics STN1NK60Z |
| R1,R16,R17 | 27 kΩ | 1% | | Metal film resistor | |
| R2,R4,R22,R24,R28 | 22 Ω | 5% | | Metal film resistor | |
| R3,R8 | 1 kΩ | 5% | | Metal film resistor | |
| R5,R37 | 47 kΩ | 5% | | Metal film resistor | |

**Table 1. BOM (continued)**

| Reference | Part / value | Tolerance% | Rating | Technology | Manufacturer |
|--|-----------------|------------|----------------------|---------------------|--------------------------------------|
| R6,R7,R46,R47 | 2 Ω | 1% | | Metal film resistor | |
| R9,R10,R12,R13,R14, R15, R35,R36,R43, R44 | 680 k Ω | 1% | | Metal film resistor | |
| R27,R29 | 3.3 k Ω | 5% | | Metal film resistor | |
| R11,R45 | 13 k Ω | 1% | | Metal film resistor | |
| R18,R19,R20,R30,R31, R50 | 10 k Ω | 1% | | Metal film resistor | |
| R21,R23 | 150 Ω | 5% | | Metal film resistor | |
| R38 | Not connected | | | Metal film resistor | |
| R32 | 30 Ω | 1% | | Metal film resistor | |
| R39 | 3.3 k Ω | 1% | | Metal film resistor | |
| R40 | 12 k Ω | 1% | | Metal film resistor | |
| R48,R49 | 470 Ω | 1% | | Metal film resistor | |
| T1 | 2x47 mH | | 1.1 A/250 V | Through hole | TK-EPC B82733F2112B001 |
| T2 | 1 mH | $\pm 15\%$ | 1.2 Arms/ 3.2 Apk | | MAGNETICA 1974.0003 |
| T3 | 0.8 mH | $\pm 15\%$ | 1.5 Arms/ 2.6 Apk | | MAGNETICA 2071.0003 |
| T4 | Turn ratio 1:12 | $\pm 10\%$ | 4 A | | MAGNETICA 2034.0001 |
| T5 | Turn ratio 1:24 | $\pm 5\%$ | 2.2 Apk | | MAGNETICA 1907.0008 |
| U1 | Input bridge | | 1 A/1000 V | | |
| U2 | L6382D5 | | 600 V | SMD | STMicroelectronics L6382D5 |
| U3 | ST7FLITE49K2T6 | | 5 V | SMD | STMicroelectronics ST7FLITE49K2T6 |

Table 1. BOM (continued)

| Reference | Part / value | Tolerance% | Rating | Technology | Manufacturer |
|-----------|--------------|------------|--------|--------------|---------------------------------|
| U4 | VIPER16LN | | 800 V | Through hole | STMicroelectronics VIPER16LN |
| HS1 | Heatsink HB | | | | |
| HS2 | Heatsink PFC | | | | |

6 PFC design rules

The front-end stage of conventional offline converters, typically consisting of a full-wave rectifier bridge with a capacitor filter, has an unregulated DC bus from the AC mains. The filter capacitor must be large enough to have a relatively low ripple superimposed on the DC level. The current from the mains is a series of narrow pulses with very high amplitude. A consequence of this condition is the distortion of the AC line voltage and a poor utilization of the power system's energy capability. This can be measured considering two parameters:

1. the total harmonic distortion (THD)
2. the power factor (PF)

Two methods of controlling a PFC preregulator are currently widely used:

1. the fixed frequency average current mode PWM (FF PWM)
2. the transition mode (TM) PWM (fixed ON-time, variable frequency)

In this application the PFC section is realized with a boost converter working in transition mode and digitally controlled. Design criteria of the PFC stage power components are explained.

6.1 Specifications

- Minimum mains voltage (RMS value): $V_{acmin} = 85 \text{ V}$
- Maximum mains voltage (RMS value): $V_{acmin} = 265 \text{ V}$
- Minimum main frequency: $f_{min} = 47 \text{ Hz}$
- Expected bridge efficiency: $\eta_{bridge} = 95\%$
- Rated lamp power: $P_{lamp} = 70 \text{ W}$
- Rated out power: $P_{out} = \frac{P_{lamp}}{\eta_{bridge}} = 73.6 \text{ W}$
- Output current: $I_{out} = \frac{P_{out}}{V_{out}} = 0.18 \text{ A}$
- Regulated DC output voltage (DC value): $V_{out} = 410 \text{ V}$
- Maximum output low-frequency Vout ripple: $V_{outx} = 20 \text{ V}$
- PFC minimum switching frequency: $f_{min} = 30 \text{ kHz}$
- Expected PFC efficiency: $\eta_{PFC} = 96\%$
- Expected Input section efficiency: $\eta_{in} = 99\%$
- Expected power factor: 0.99.

6.2 Operating conditions

- Expected input power: $P_{in} = \frac{P_{lamp}}{\eta_{Bridge} \cdot \eta_{PFC} \cdot \eta_{in}} = \frac{150}{0.95 \cdot 0.96 \cdot 0.99} = 77.5 \text{ W}$
- Maximum RMS input current: $I_{in} = \frac{P_{in}}{V_{acmin} \cdot PF} = \frac{77.5}{85 \cdot 0.99} = 0.92 \text{ A}$

- Maximum peak inductor current: $I_{LPK} = 2 \cdot \sqrt{2} \cdot I_{in} = 2 \cdot \sqrt{2} \cdot 0.92 = 2.61A$
- Maximum RMS inductor current: $I_{L1} = \frac{2}{\sqrt{3}} \cdot I_{in} = \frac{2}{\sqrt{3}} \cdot 0.92 = 1.06A$
- Maximum RMS diode current: $I_{D10} = I_{L1pk} \sqrt{\frac{4 \cdot \sqrt{2}}{9 \cdot \pi} \cdot \frac{V_{acmin}}{V_{out}}} = 0.53A$

6.3 Power components

6.3.1 Input capacitor

To calculate the input capacitor the following relationship can be used:

Equation 5

$$C_{in} = \frac{I_{in}}{2 \cdot \pi \cdot f_{swmin} \cdot r \cdot V_{acmin}} = \frac{0.92}{2 \cdot \pi \cdot 30k \cdot 0.1 \cdot 85} = 220nF$$

Using $r=0.25$ a commercial value of 220 nF was selected. A bigger capacitor improves the EMI behavior but worsens the THD.

6.3.2 Output capacitor

The output bulk capacitor selection depends on the DC output voltage and the converter output power.

Equation 6

$$C_o = \frac{P_{out}}{4 \cdot \pi \cdot f_{min} \cdot V_{out} \cdot \Delta V_{out}} = \frac{70}{4 \cdot \pi \cdot 47 \cdot 410 \cdot 20} = 31\mu F$$

Considering the tolerance of the electrolytic capacitors and in the capacitor divider two capacitors are connected in series, 100 μF 250 V was selected.

6.3.3 Boost inductor

The boost inductor must be calculated at minimum and maximum Vac. The minimum inductance value must be selected.

Equation 7

$$L1 = \frac{V_{ac}^2 \cdot (V_{out} - \sqrt{2} \cdot V_{ac})}{2 \cdot f_{swmin} \cdot Pin \cdot V_{out}}$$

Equation 8

$$L_{1max} = \frac{185^2 \cdot (420 - \sqrt{2} \cdot 85)}{2 \cdot 30k \cdot 77.5 \cdot 420} = 1.1mH$$

Equation 9

$$L_{1min} = \frac{265^2 \cdot (420 - \sqrt{2} \cdot 265)}{2 \cdot 30k \cdot 166 \cdot 420} = 1.3mH$$

For this application boost inductance of 1 mH has been chosen.

6.3.4 Power MOSFET selection

For Power MOSFET selection the breakdown voltage and the $R_{DS(on)}$ must be considered.

The MOSFET used in this section is the STF11NM60ND.

Thermal measurements have confirmed this as the right choice for this device.

6.3.5 Boost diode selection

The PFC section is realized with a boost converter working in transition mode. The STTHxL06 family, which is using ST Turbo2 600 V technology, is specially suited as the boost diode in discontinuous or transition mode power factor corrections.

The selection criteria is based on breakdown voltage and current. A rough selection can be performed adopting the following criterion:

- The breakdown voltage must be higher than $(V_{out} + \Delta V_{op}) + \text{margin}$
- The diode current must be higher than 3 times the average current I_{out} .

In this case STTH1L06 has been chosen.

The average diode current is:

Equation 10

$$I_{out} = \frac{P_{out}}{V_{lamp}} = 0.18A$$

Use the following equation to evaluate the conduction losses:

Equation 11

$$P_{D10} = 0.89 \cdot I_{out} + 0.165 \cdot I_{D10}^2 = 0.22W$$

Considering $T_{jmax} = 150 \text{ }^\circ\text{C}$ and the maximum ambient temperature $T_{ambmax} = 50 \text{ }^\circ\text{C}$, it is possible to calculate the $R_{THJ-amb}$ as follows:

Equation 12

$$R_{THJ-amb} = \frac{T_{jmax} - T_{ambmax}}{P_{diode}} = \frac{150 - 50}{0.43} = 465^\circ\text{C} / W$$

The calculated R_{th} is higher than the STTH1L06 (diode $R_{Tj-a} = 70 \text{ }^\circ\text{C/W}$) thermal resistance junction-ambient, so no heatsink is needed.

In any case, thermal measurement confirms the real device temperature.

7 Auxiliary power supply

The proposed power supply can be successfully applied in an application requiring 15 V for the power switch gate driver. This is a cost effective solution in terms of size and performances.

It is based on the VIPER16LN in non-isolated buck configuration. The schematic is shown in [Figure 10](#).

The auxiliary voltage is fixed considering the regulation point on the FB pin. An external resistor divider is designed in order to set 3.3 V on the FB pin when output voltage is 15 V.

Figure 10. Auxiliary power supply

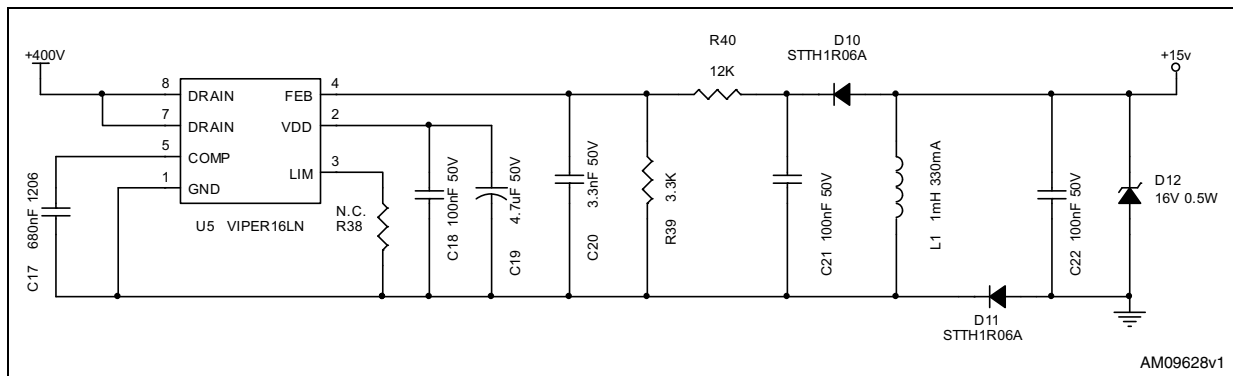

8 ST7 microcontroller application pin use

Figure 11. ST7FLITE49K2 pinout

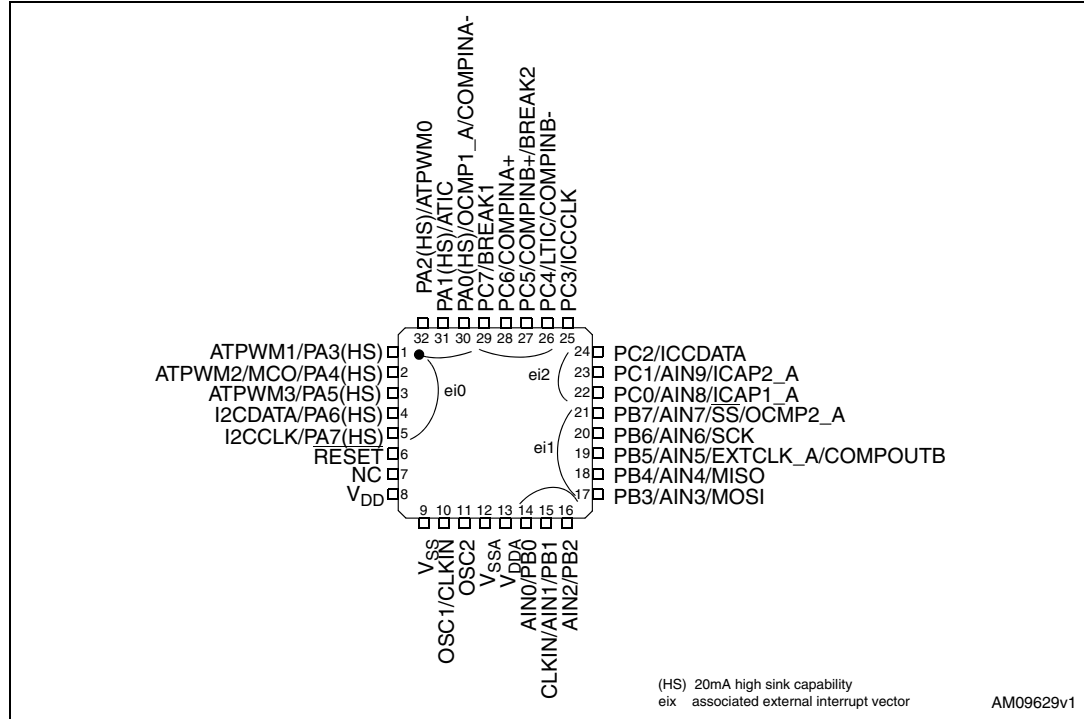

- Pin 1: not used
- Pin 2: not used
- Pin 3: MCU PWM3. Output used for PFC gate driver
- Pin 4: not used
- Pin 5: not used
- Pin 6: MCU reset: In [Figure 12](#) the reset circuit is shown.

Figure 12. Reset circuit

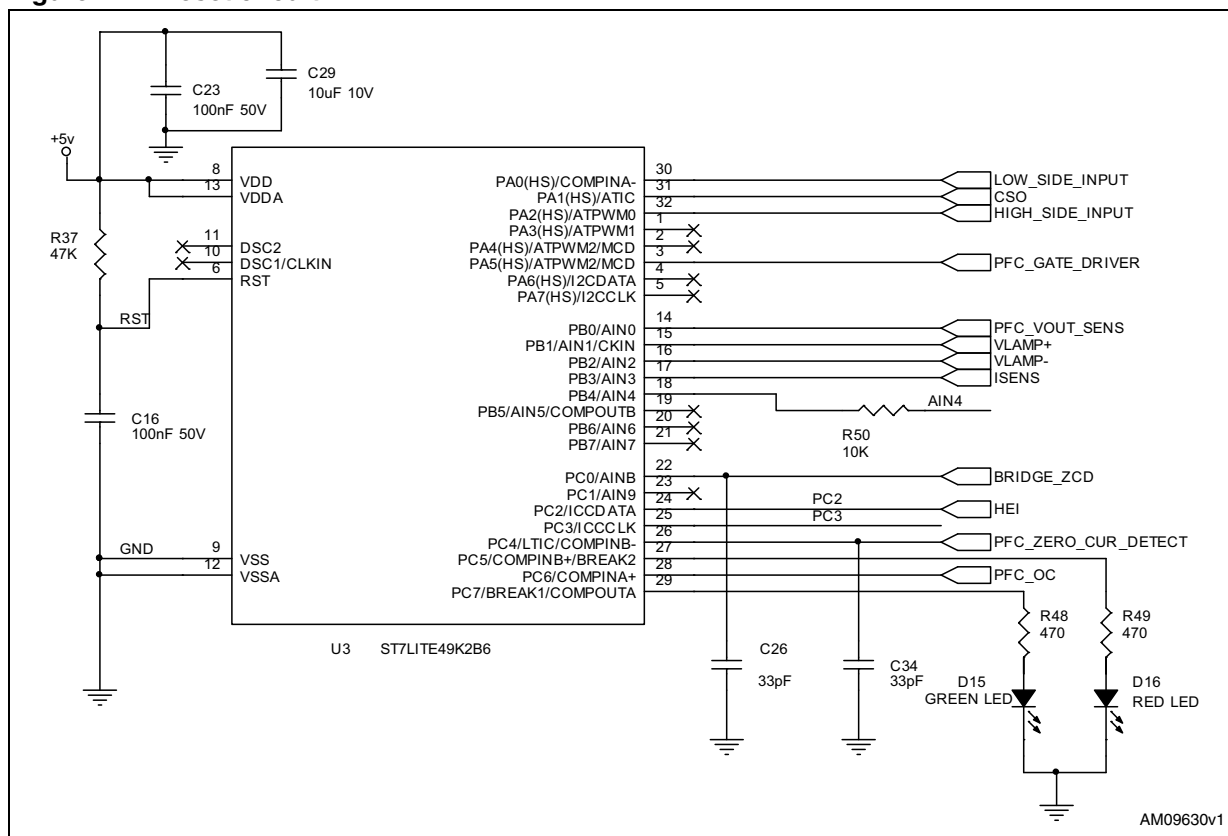

The net connected to the RST pin is composed of R37 = 47 kΩ and C16 = 100 nF. This net is used to detect if the reference voltage has reached 5 V. The MCU gives a reset if the +5 V level voltage is not reached.

- Pin 7: not used
- Pin 8: VDD MCU supply voltage
- Pin 9: GND
- Pin 10: not used
- Pin 11: not used
- Pin 12: GND
- Pin 13: VDD MCU supply voltage. It is obtained using the Vref pin of the L6382D5 and is able to supply 5 V with ± 2% of tolerance
- Pin 14: MCU analogue input channel 0 used for PFC Vout measurement. A resistor divider is connected at the PFC output in order to obtain the feedback signal. It is designed to obtain a voltage compatible with 5 V MCU voltage.

The net for Vbus measurement is shown in [Figure 13](#).

Figure 13. PFC Vout sense. Resistor divider

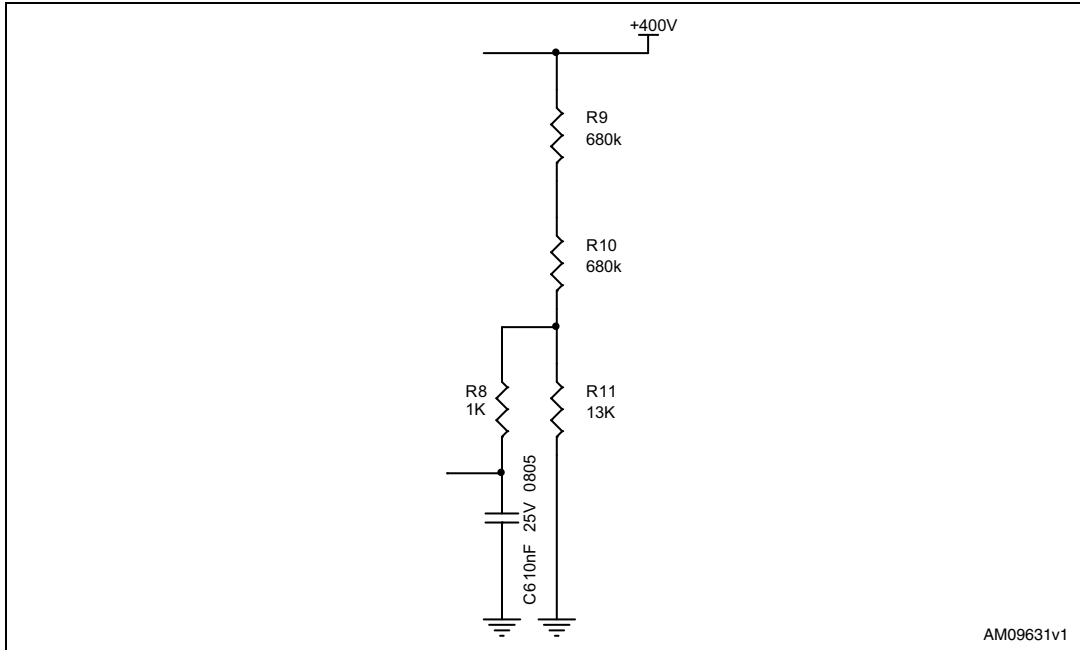

- Pin 15: MCU analogue input PB1 (AIN1) used for PFC Vlamp+ measurement
- Pin 16: MCU analogue input PB2 (AIN2) used for PFC Vlamp- measurement.

Figure 14. PFC Vlamp measurements. Resistor dividers

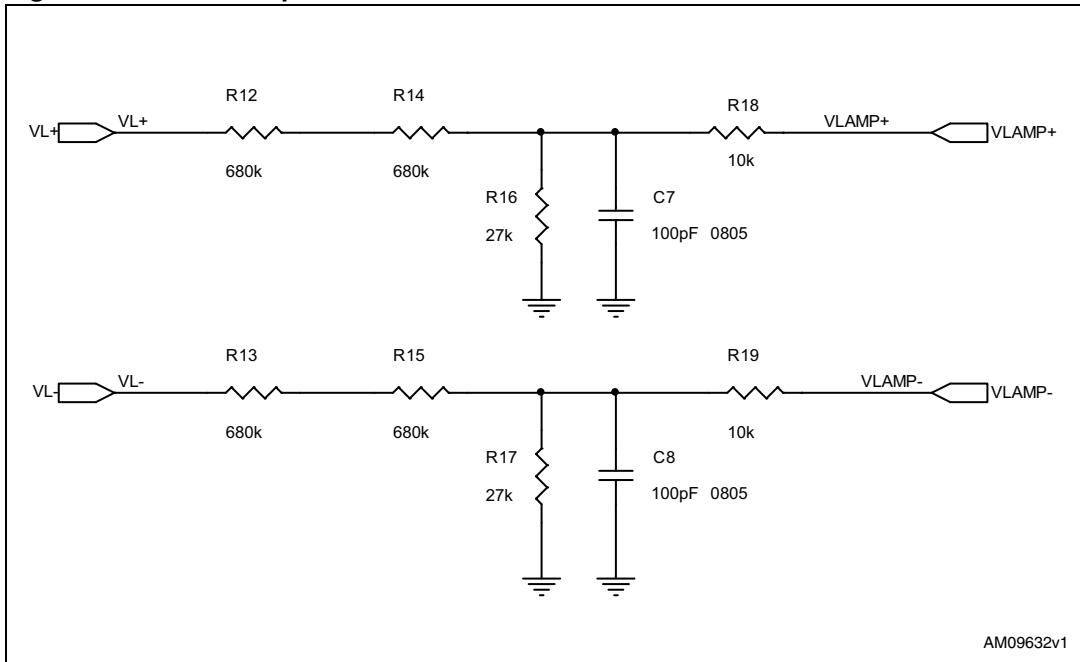

The lamp voltage feedback signal is obtained directly connecting a resistor divider to the lamp. It is designed to obtain a voltage on Vlamp- and Vlamp+ compatible with 5 V MCU voltage.

In [Figure 14](#) the circuit for V_{lamp} measurement is shown.

- Pin 17: MCU analogue input PB3 (AIN3) used for lamp current measurement.

Figure 15. Isense measurement circuit

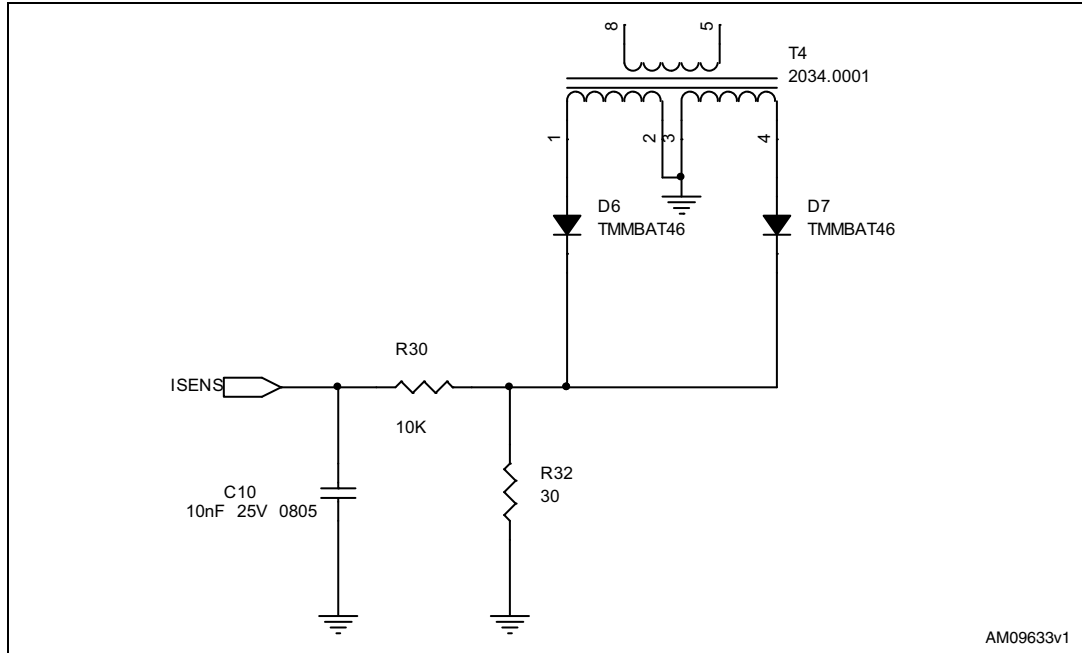

The above circuit uses a current transformer to generate the feedback signal on the R32 resistor.

The turn ratio of the current transformer is designed to obtain a voltage signal compatible with 5 V of MCU.

- Pin 18: MCU analogue input PB4 (AIN4). This pin is used for Vin input mains measurement.
- Pin 19: not used
- Pin 20: not used
- Pin 21: not used
- Pin 22: MCU PC0. Zero current detect for half bridge current.

Figure 16. Half bridge ZCD circuitry

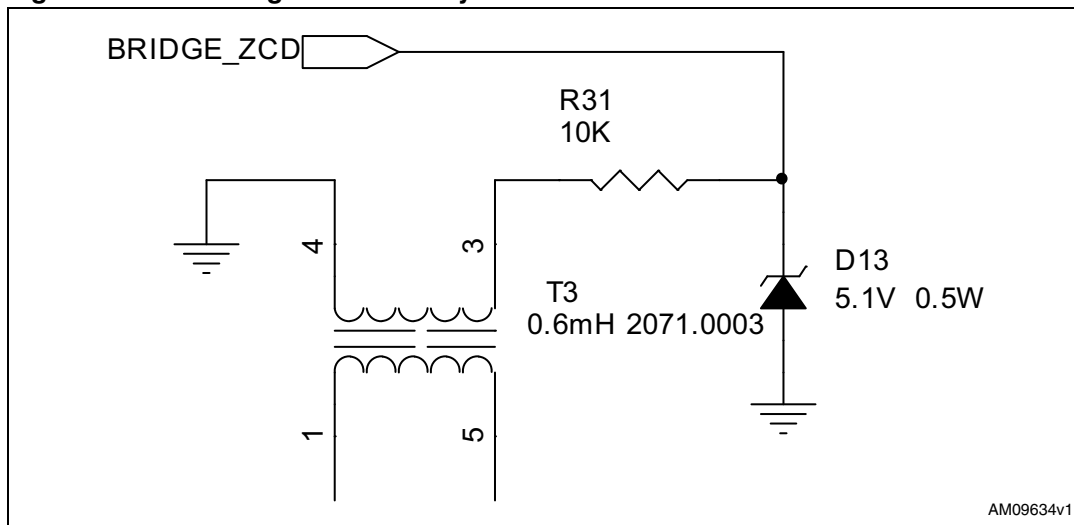

The buck circuit realized in the half bridge works in transition mode. To obtain this feature an auxiliary winding is wound in the main inductor of the half bridge and when the current reaches the zero value the variation of voltage is used by the PC0 pin of the microcontroller to start the conduction of the power switches.

- Pin 23: not used
- Pin 24: HEI: MCU output used for igniter gate driver.

Figure 17. Enable/disable igniter circuitry

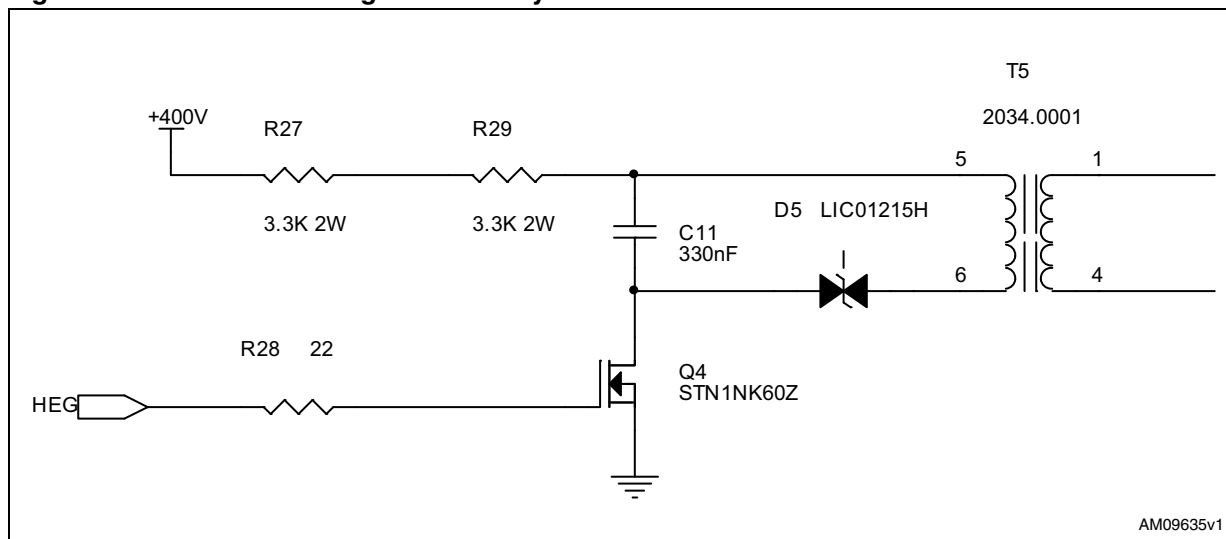
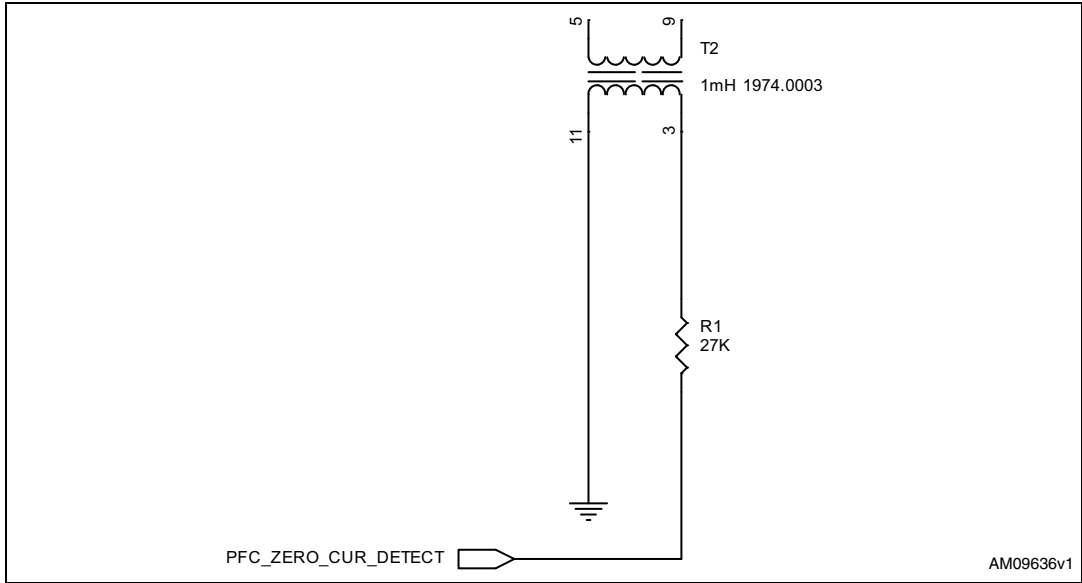

Figure 16 shows that Q4 enables or disables the charge of capacitor C11. When the voltage exceeds the voltage across D5, the discharge happens and in the primary winding the generated high voltage ignites the lamp. The microcontroller generates a signal for the L6382D5 that drives Q4. This pin is used also for microcontroller flash programming.

- Pin 25: PC3 this pin is used also for microcontroller flash programming
- Pin 26: LTIC PFC zero current detect.

Figure 18. PFC ZCD circuitry



The boost converter of the PFC works in transition mode. To obtain this feature an auxiliary winding is wound in the main inductor of the half bridge and when the current reaches the zero value the variation of voltage used by the LTIC pin of the microcontroller starts the conduction of the switch.

- Pin 27: general purpose input-output pin. This pin is used to switch on a red LED indicating fault condition.
- Pin 28: PFC OC, this pin is used to perform overcurrent on the PFC section avoiding saturation of the inductor. In [Figure 18](#) it is possible to see that an RC filter composed of R3 and C5 is inserted to avoid unexpected switch-off due to the noise in the circuit. This protection is not implemented.

Figure 19. PFC_OC circuitry

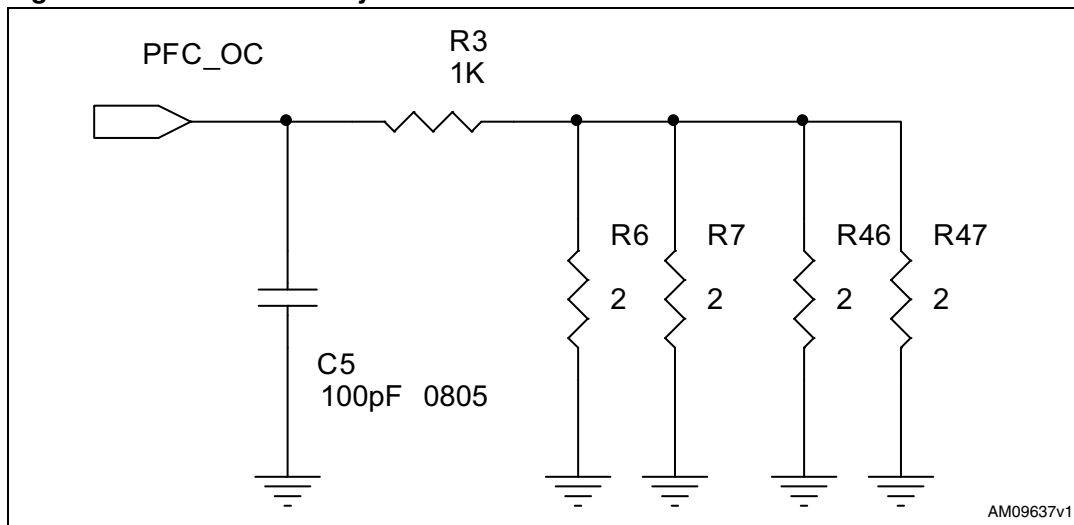

- Pin 29: general purpose input-output pin. This pin is used to switch on a green LED indicating that all the electrical parameters are in the right range and the board is working.
- Pin 30: low side input MCU PWM1. Output used to drive half bridge low-side gate driver.
- Pin 31: CSO general purpose input-output pin. This pin is used to switch off all the circuit if the voltage on this pin is high.
- Pin 32: general purpose input-output pin. This pin is used to generate low frequency signal for half bridge.

9 Half bridge operation

Init phase

After the startup of the auxiliary power supply gives the right voltage at the L6382D5, the auxiliary supply voltage for the microcontroller is generated. After this sequence the microcontroller gives the right startup signals at the driver.

Ignition phase

The ignition voltage is generated by the high voltage transformer. On primary winding a voltage is generated by means of a capacitive discharge. The differential of potential is transferred (high voltage) at secondary winding causing lamp ignition. The voltage level across the lamp is about 3 kV.

Warm-up phase

During this phase a relative high current must be supplied to avoid the lamp extinguishing. In this case the maximum lamp current is limited at 30% higher than the nominal value.

Burn phase

In this phase the lamp power must be controlled regulating the lamp current. To avoid acoustic resonance the lamp is driven with low frequency square wave current.

Current sensing

The current is monitored measuring the voltage across an R_{sense} obtained by a current transformer. This signal is filtered in order to obtain information on the real average current that flows in the lamp. This signal is the feedback used by the MCU.

Voltage sensing

The lamp voltage is obtained measuring the voltage across the lamp, filtering this signal, and sending this signal to ADC of the microcontroller. In this way the lamp voltage is controlled directly by the MCU.

Lamp power management

The lamp power is obtained multiplying the lamp voltage signal for the lamp current.

The lamp voltage is sensed directly across the lamp. The lamp current is obtained considering the feedback signal coming from the current sense circuit.

The MCU calculates the lamp power multiplying the value of lamp current for the lamp voltage.

10 Half bridge design criteria

The design of the half bridge section involves the magnetic component and the device selection.

Buck inductor

Consider that, in this project, an inductor of 600 μH was selected.

PMOS selection

The selected PMOS for half bridge is: STF11NM60ND. The system shows very good efficiency using this device.

11 Lamp operating point

For correct operation in each phase different electrical values (voltage and current) must be applied. The chosen values for each phase are reported below.

Ignition phase

The ignition voltage, in case of a cold lamp, is about 3-5 kV. The ignition voltage increases with increasing lamp temperature. The ignition voltage in case of a hot re-strike can reach 25 kV.

The circuit is not designed for hot re-strike.

Warm-up phase

During this phase a high warm-up current must be supplied (30% higher than nominal current) to prevent the lamp extinguishing. The lamp voltage increases gradually starting from a quarter to nominal lamp voltage up to the nominal value. The warm-up time is about 2 minutes.

For the specified lamp, 70 W metal halide lamp, a current of 1 Arms was applied.

Burn phase

The lamp is designed to be driven with a low frequency square wave AC current to avoid acoustic resonance of the electric arc.

Acoustic resonance occurs approximately in the frequency domain: 1 kHz - 1 MHz. Some frequency range free of acoustic resonance exists.

The commutating frequency of the half bridge should be limited to the domain 50 Hz - 1 kHz to avoid any risk on acoustic resonance. In this application the commutating frequency has been chosen in 160 Hz.

The nominal lamp voltage during burn phase is approximately 100 V and the nominal lamp power is 70 W.

The differential resistance of the lamp is small and negative. To obtain a stable operating point, inductive impedance in series with the lamp is needed.

12 STEVAL-ILH004V1: experimental results

These results have been obtained at input voltage between 85 and 265 V. Ambient temperature: 23 °C.

12.1 Half bridge section

During this phase the lamp is supplied with low frequency square wave current. The lamp current and the lamp power are maintained constant, some waveforms are shown below.

Figure 20. Steady-state phase: lamp current, voltage and lamp power

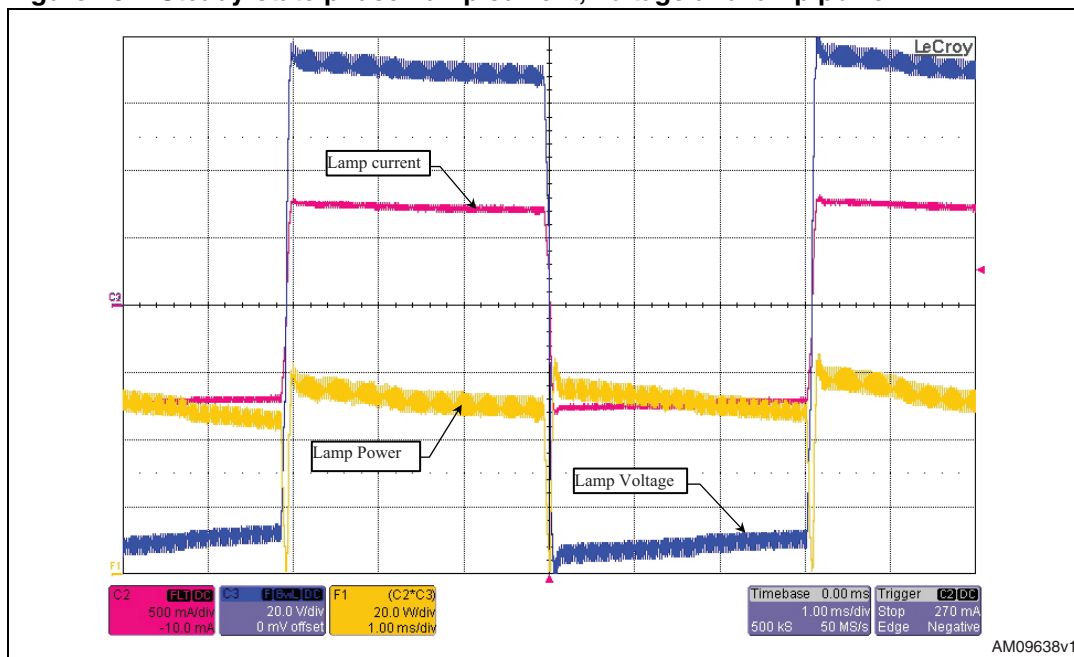
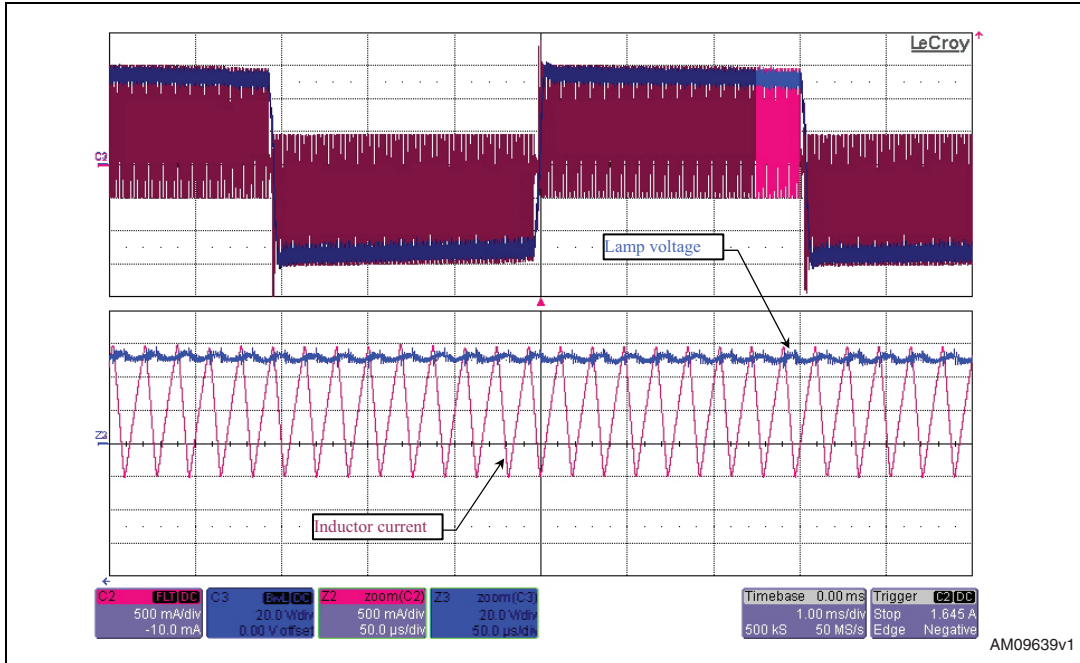

Figure 21. Steady-state phase: inductor current and lamp voltage



12.2 PFC section

During run phase the input power, the power factor, and the input current THD have been measured. Results are reported below:

Figure 22. STEVAL-ILH004V1: power factor vs. input voltage

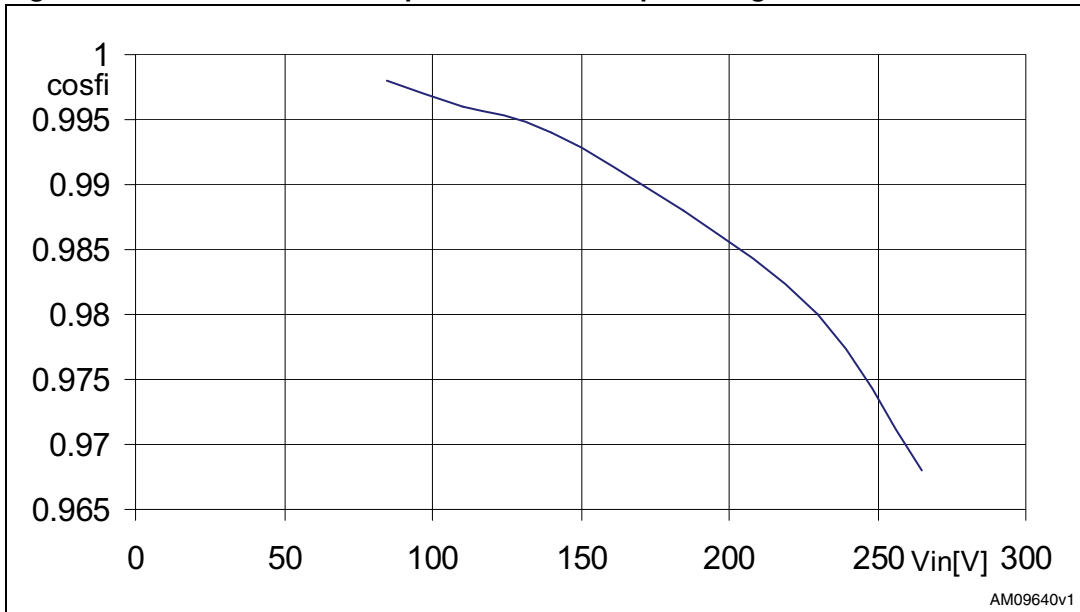

Figure 23. STEVAL-ILH004V1: THD% vs. input voltage

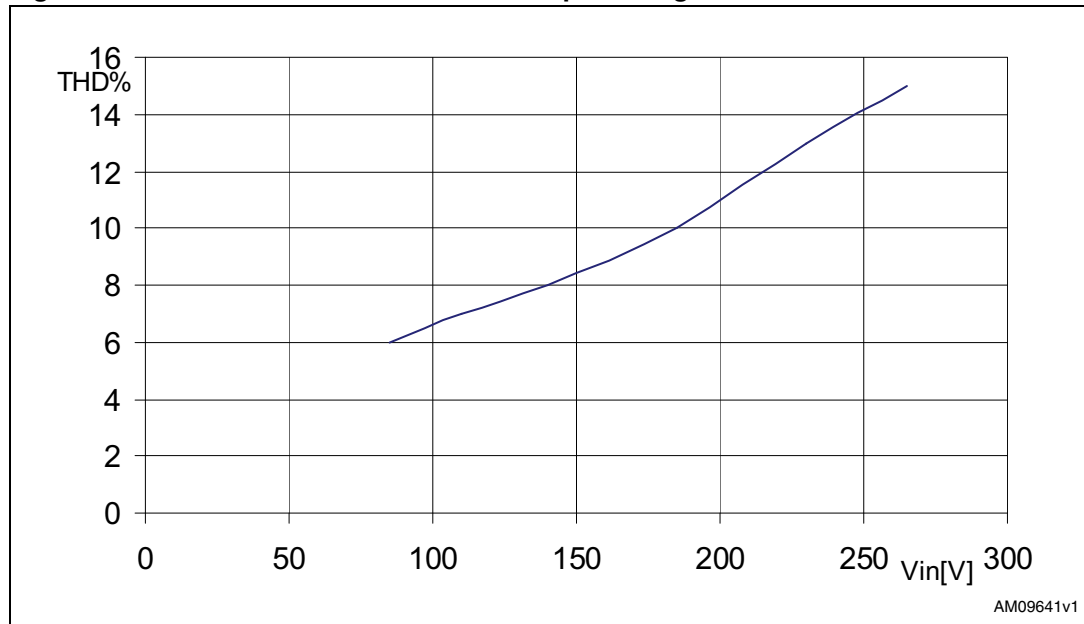
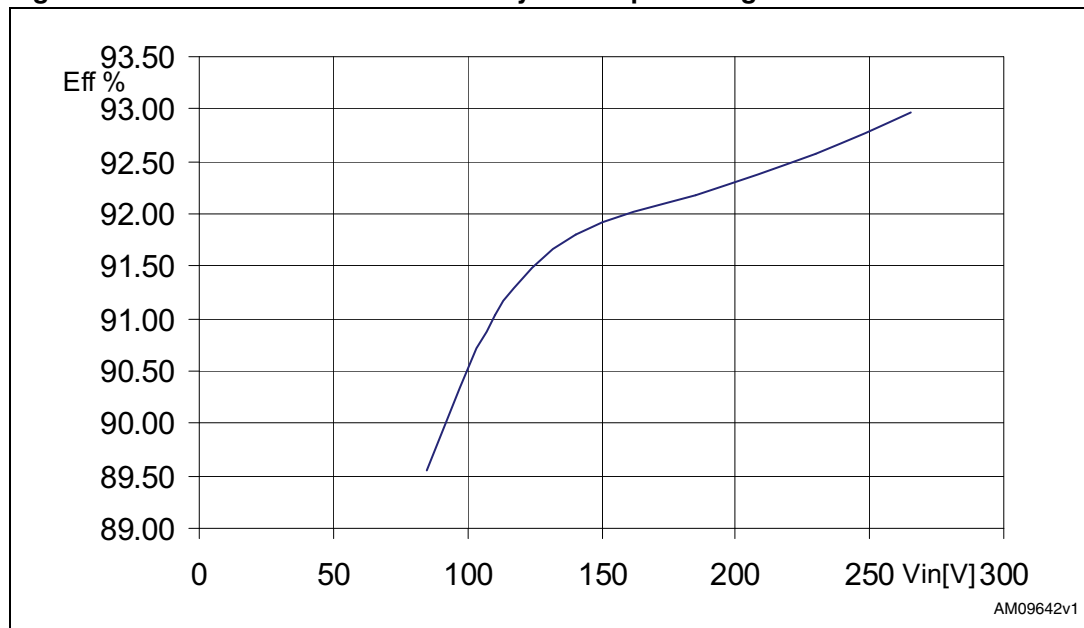

Figure 24. STEVAL-ILH004V1: efficiency% vs. input voltage



As can be seen, the board has a good efficiency and power factor, the THD is good at 110 V input range but exceeds 10% at 230 V. It is possible to reduce this value reducing the PFC input capacitor and increasing the output voltage. In any case, the board globally offers good performance in this condition.

12.3 Conducted emission pre-compliance tests

Tests have been performed in order to evaluate the electromagnetic compatibility and the disturbance of the STEVAL-ILH004V1. The measurements have been performed in the line wires, using a peak detector and considering average and quasi peak limits according to EN 55015 standards. The tests have been performed at 230 Vac input voltage. Results show that emission levels are below the limits.

Figure 25. STEVAL-ILH004V1: peak measurement

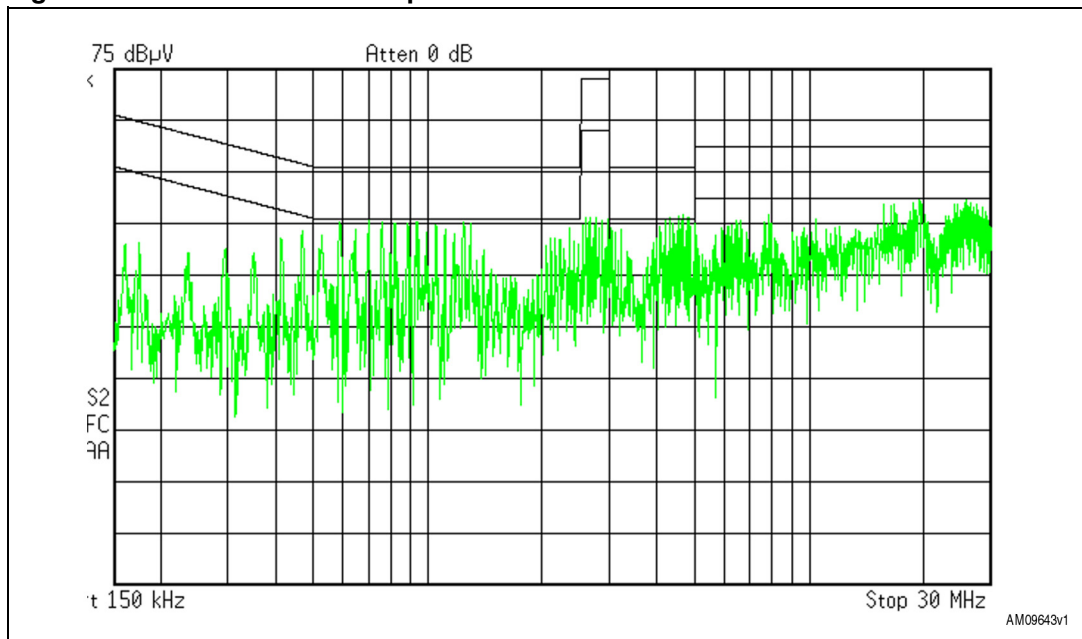

13 Conclusion

Several tests on HID ballast have been performed. Using the proposed setting the ballast works properly according to all the lamp specifications. The system shows very good efficiency.

14 Reference

1. AN2747 application note
2. L6382D5 datasheet
3. ST7LITE49K2

15 Revision history

Table 2. Document revision history

| Date | Revision | Changes |
|-------------|----------|------------------|
| 09-Jan-2013 | 1 | Initial release. |

Please Read Carefully:

Information in this document is provided solely in connection with ST products. STMicroelectronics NV and its subsidiaries ("ST") reserve the right to make changes, corrections, modifications or improvements, to this document, and the products and services described herein at any time, without notice.

All ST products are sold pursuant to ST's terms and conditions of sale.

Purchasers are solely responsible for the choice, selection and use of the ST products and services described herein, and ST assumes no liability whatsoever relating to the choice, selection or use of the ST products and services described herein.

No license, express or implied, by estoppel or otherwise, to any intellectual property rights is granted under this document. If any part of this document refers to any third party products or services it shall not be deemed a license grant by ST for the use of such third party products or services, or any intellectual property contained therein or considered as a warranty covering the use in any manner whatsoever of such third party products or services or any intellectual property contained therein.

UNLESS OTHERWISE SET FORTH IN ST'S TERMS AND CONDITIONS OF SALE ST DISCLAIMS ANY EXPRESS OR IMPLIED WARRANTY WITH RESPECT TO THE USE AND/OR SALE OF ST PRODUCTS INCLUDING WITHOUT LIMITATION IMPLIED WARRANTIES OF MERCHANTABILITY, FITNESS FOR A PARTICULAR PURPOSE (AND THEIR EQUIVALENTS UNDER THE LAWS OF ANY JURISDICTION), OR INFRINGEMENT OF ANY PATENT, COPYRIGHT OR OTHER INTELLECTUAL PROPERTY RIGHT.

UNLESS EXPRESSLY APPROVED IN WRITING BY TWO AUTHORIZED ST REPRESENTATIVES, ST PRODUCTS ARE NOT RECOMMENDED, AUTHORIZED OR WARRANTED FOR USE IN MILITARY, AIR CRAFT, SPACE, LIFE SAVING, OR LIFE SUSTAINING APPLICATIONS, NOR IN PRODUCTS OR SYSTEMS WHERE FAILURE OR MALFUNCTION MAY RESULT IN PERSONAL INJURY, DEATH, OR SEVERE PROPERTY OR ENVIRONMENTAL DAMAGE. ST PRODUCTS WHICH ARE NOT SPECIFIED AS "AUTOMOTIVE GRADE" MAY ONLY BE USED IN AUTOMOTIVE APPLICATIONS AT USER'S OWN RISK.

Resale of ST products with provisions different from the statements and/or technical features set forth in this document shall immediately void any warranty granted by ST for the ST product or service described herein and shall not create or extend in any manner whatsoever, any liability of ST.

ST and the ST logo are trademarks or registered trademarks of ST in various countries.

Information in this document supersedes and replaces all information previously supplied.

The ST logo is a registered trademark of STMicroelectronics. All other names are the property of their respective owners.

© 2013 STMicroelectronics - All rights reserved

STMicroelectronics group of companies

Australia - Belgium - Brazil - Canada - China - Czech Republic - Finland - France - Germany - Hong Kong - India - Israel - Italy - Japan - Malaysia - Malta - Morocco - Philippines - Singapore - Spain - Sweden - Switzerland - United Kingdom - United States of America

www.st.com

