TVS devices for power line communication applications

Introduction

All communication applications are bound to comply with electro-magnetic compatibility (EMC) standards, whose requirements depend on the application environment.

This Application Note aims at explaining how to use transient voltage suppressor (TVS) devices to protect power line communication (PLC) circuits against electrical over-Stress (EOS) and specifically against surge events as defined by IEC 61000-4-5 and EN50065-2-3 international standards.

Even though 4 kV test level is required as maximum withstand level by the aforementioned application standards, for this Application Note a PLC circuit has been tested against 6 kV surges; this higher level is often required by customers for higher confidence or specific applications. Tests performed and results will be presented, focusing in the end on an optimized PLC protection solution.

Application description

Power line communication can be used in various applications such as smart metering, home automation, street lighting, solar inverters and so on.

In all cases, the PLC circuit will be coupled to a power line (AC or DC) with high probability of high-energy transients, potentially causing EOS events that could damage the application.

The application conditions described above create the need for specific protection devices to be included in the power line coupling circuit.

Tests on adequate protection devices have been performed using the ST demonstration kit EVALKITST7580-1. Built around the ST7580 power line networking system-on-chip, this demonstration kit embeds all the functions required for a “turn-key” power line communication network: the PLC node based on the ST7580, the AC power supply (based on the ALTAIR4-900 chip) and the STM32 microcontroller, to either control the system as a standalone application or to connect the EVALKITST7580-1 to an external host.

For all EVALKITST7580-1 documentation, including Application Note, schematics, and PCB layout, please go to ST PLC products webpage or EVALKITST7580-1 webpage.

Figure 1. EVALKITST7580-1 functional block diagram

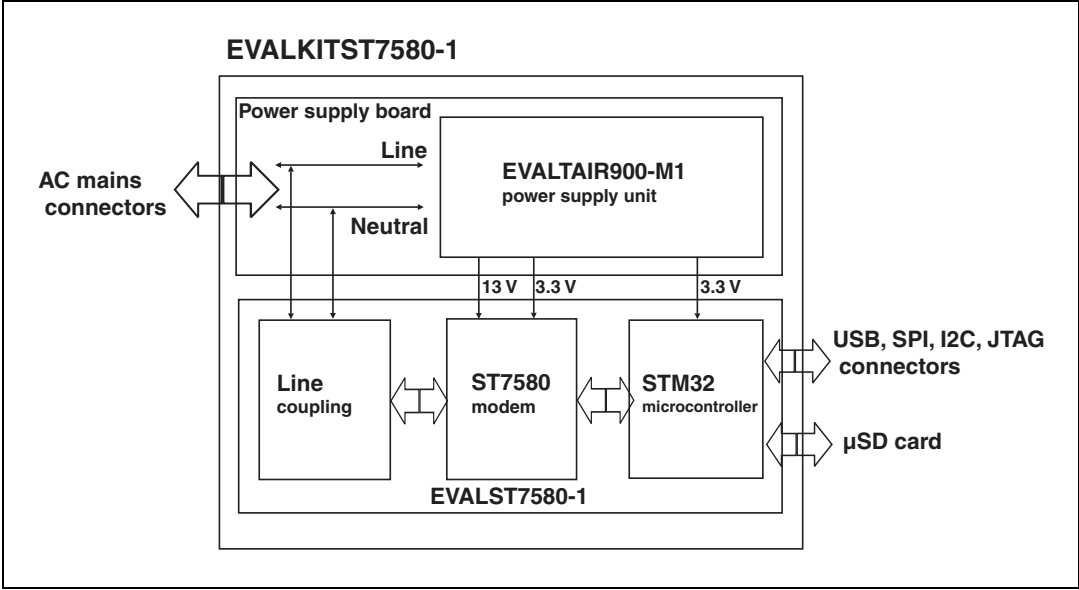

1 Transient voltage suppressor devices

The working principle of a TVS is the following: Once the voltage at TVS node exceeds the breakdown voltage V_{BR} , the TVS will clamp the voltage across it, reaching a clamping level V_{CL} that depends on the current flowing through the TVS

Two kinds of TVS can be used: unidirectional or bidirectional.

Unidirectional

A unidirectional TVS clamps the voltage differently depending on the direction ($V > 0$ or $V < 0$).

For $V > 0$, it will act as a diode in forward conduction, with a clamping voltage below 1 V, generally around 0.7 V.

For $V < 0$, the voltage will be able to vary from 0 V to $-V_{BR}$ but will be clamped to $-V_{CL}$ if a surge tries to force it lower.

Figure 2. Unidirectional TVS behavior

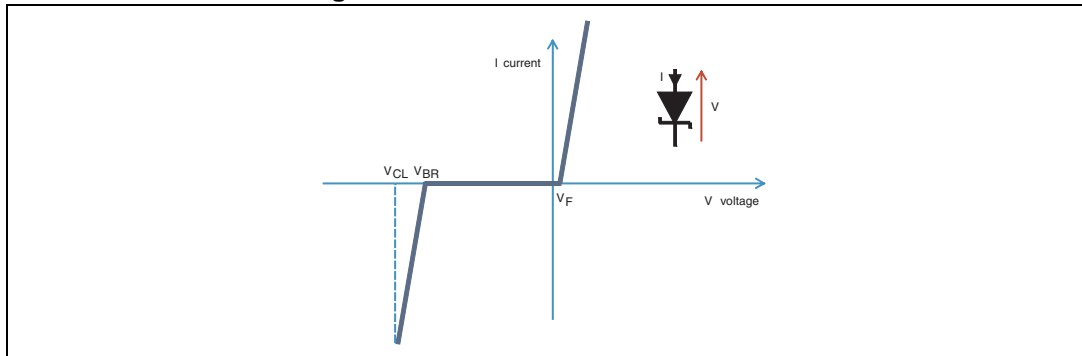

Bidirectional

A bidirectional TVS clamps the voltage in the same way whatever the direction ($V > 0$ or $V < 0$).

The voltage will be able to vary from $-V_{BR}$ to $+V_{BR}$ but will be clamped to $-V_{CL}$ or V_{CL} if a surge tries to push voltage out of boundaries.

Figure 3. Bidirectional TVS behavior

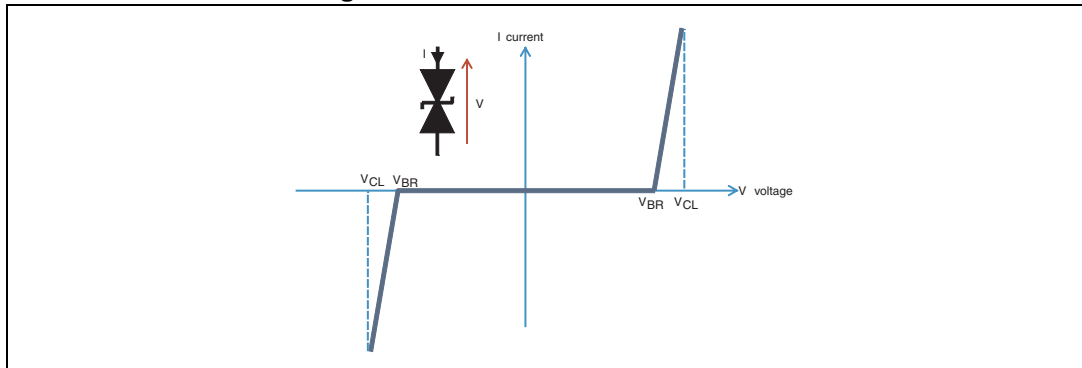

2 Description of the EMC standards for surge tests

Surge waveforms and levels are defined in the IEC 61000-4-5 standard. The standard defines the surge waveforms and the test levels separately: the surge voltage and current waveforms have always the same shape and timings, while the voltage and current levels depend on the test and the application specifications.

2.1 Voltage and current waveforms

The surge generator is specified in terms of open circuit voltage and short circuit current in order to have the correct waveform.

Figure 4. EC61000-4-5 voltage setup circuit and waveform (1.2/50 μ s)

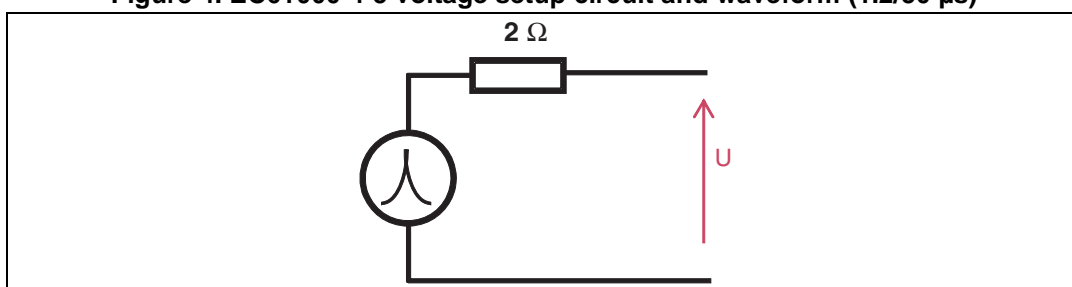
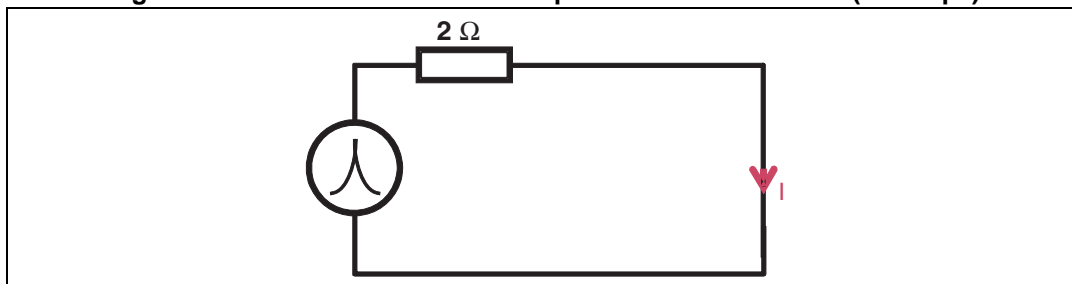

Figure 5. IEC61000-4-5 current setup circuit and waveform (1.2/50 μ s)



2.2 Power line communication EMC standards

In Europe, the requirements to be satisfied by PLC applications are stated in the EN50065 2-x documents, all referring to IEC61000-4-5 standard for surge definition:

EN50065-2-1: for residential, commercial and light industrial environment (i.e. Home Automation and similar)

EN50065-2-2: for industrial environments (i.e. industrial command & control)

EN50065-2-3: for use by electricity suppliers and distributors (i.e. AMR/AMI)

The most stringent requirements are set by the EN50065-2-3 part and ask for ± 4 kV 1.2/50 μ s (8/20 μ s) withstanding in both differential and common-mode surge coupling.

However, to match higher requirements set by some applications and customers, ± 6 kV level has been applied.

2.3 Surge test levels

Surge levels should be selected according to application environment. [Table 1](#) below provides the different voltage levels and environment description according to IEC61000 4 5:

Table 1. Voltage levels and environment description according to IEC61000-4-5

Class	Environment	Voltage level
0	Well protected environment, often in a special room	25 V
1	Partially protected environment	500 V
2	Electrical environment where the cables are well separated, even at short runs	1 kV
3	Electrical environment where power and signal cables run in parallel	2 kV
4	Electrical environment where the interconnections include outdoor cables along with the power cable, and cables are used for both electronics and electric circuits	4 kV
5	Electrical environment for electronic equipment connected to telecommunication cables and overhead power lines in a non-densely populated area	Same as class 4

Series resistance of the surge generator depends on the surge application mode:

- When the surge is applied in differential mode (i.e. surge applied between lines), the series resistance is $2\ \Omega$
- When the surge is applied in common mode (i.e. between a line and the ground), series resistance is $12\ \Omega$ ($2\ \Omega + 10\ \Omega$).

As the surge current impacts on the power rating of the protection devices, the table below shows the maximum peak current values depending on voltage level and series resistance.

Table 2. Surge current vs. source impedance and surge level

	Class 0 25 V	Class 1 500 V	Class 2 1 kV	Class 3 2 kV	Class 4 4 kV
$R = 12\ \Omega$	2.1 A	42 A	84 A	167 A	334 A
$R = 2\ \Omega$	12.5 A	250 A	500 A	1000 A	2000 A

[Figure 6](#) shows how the surge is applied to the EUT in both differential and common-mode configurations.

Figure 6. IEC61000-4-5 surge application to EUT

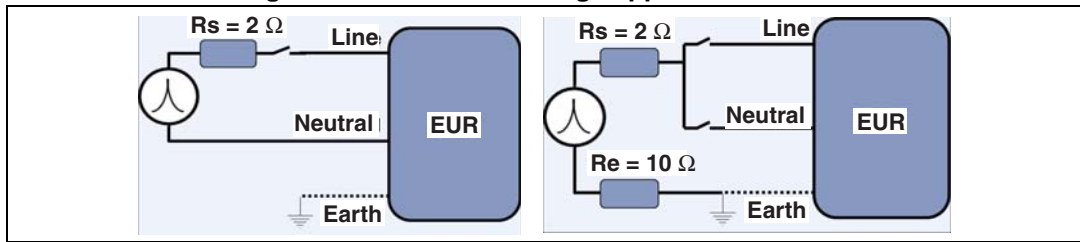

3 Surge tests

3.1 Test setup

The setup described below and used for the tests reported in this document is in accordance with EN50065-2-3.

The equipment under test (one EVALKITST7580-1 as EUT, receiving PLC frames) and a corresponding device (another EVALKITST7580-1 as stimulus, transmitting PLC frames) are used to establish that, after applying the surge test, communication between the two devices is still possible.

The boards are supplied via two separated Isolation Transformers (IT) plus two Line Impedance Stabilization Networks (LISN) named A and B. LISNs are built according to EN50065-1 specifications. Measurement ports of the LISNs are terminated in 50 to maintain the network characteristics.

Two 660 μH inductors are connected between each of the two conductors of the LISN output, used to provide a controlled signal coupling between the EUT and the stimulus.

The surge generator is connected in parallel with the EUT through the appropriate Coupling / Decoupling Network (CDN).

Figure 7. Test setup block diagram

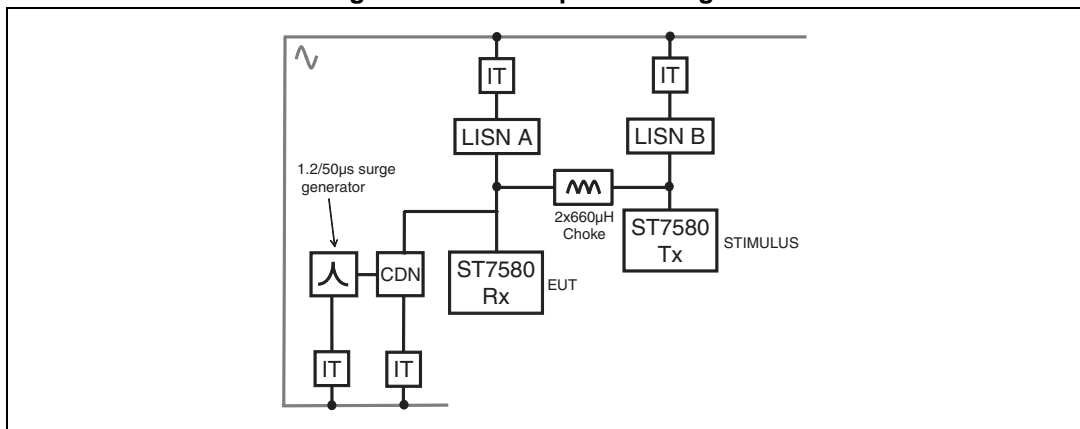

3.2 PLC circuit description

The PLC coupling circuit comprises three levels of protection, exploiting different protection devices:

Direct power line protection: a Metal Oxide Varistor (MOV) is used as a first-line protection to clamp most of the surge energy. The part number for the EVALKITST7580-1 is S14K320.

Line coupling primary side protection: it is implemented through a bidirectional TVS diode put within the L-C series resonance. This position, thanks to the resonance, gives best protection while limiting the current flowing through the TVS.

Secondary side protection at pin level: two pins of the PLC device are directly connected to the line coupling:

- PA_OUT: it is the line driver output of the PLC device forcing the transmission signal to the power line. This is the most sensitive point to be protected. Two Schottky diodes are used to clamp any residual disturbance exceeding VCC or going below ground. The part number for the EVALKITST7580-1 is STPS1L30A.
- RX_IN: it is the high-impedance receiving input of the PLC device. It is protected by a bidirectional TVS diode put just before the dc-decoupling capacitor connected in series with the pin.

The following tests and analysis will focus on the two TVS diodes included in the PLC circuit.

Figure 8. PLC circuit schematic

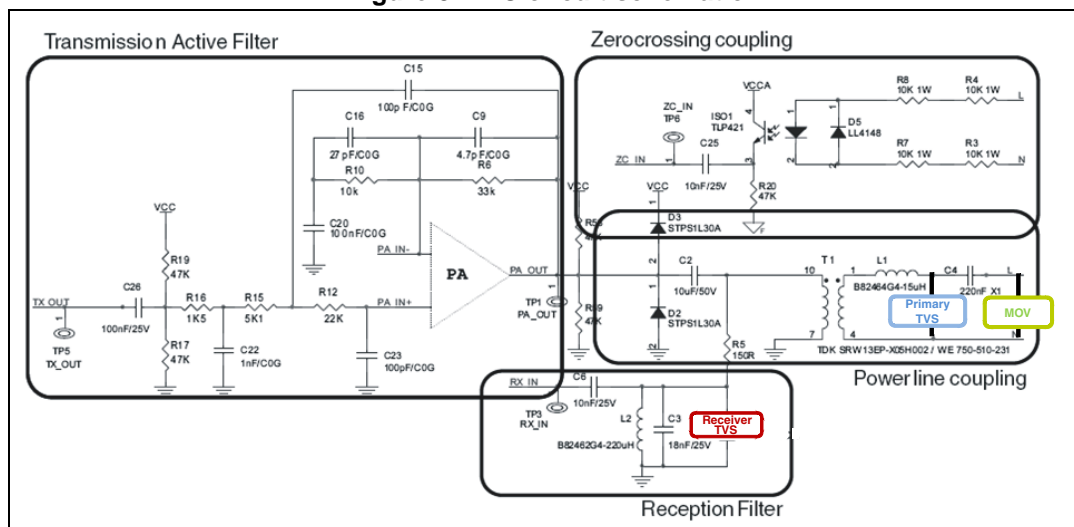

Figure 8 shows PLC circuit used for the tests, based on the ST7580 power line modem TVS and MOV highlighted.

3.3 Test results

Tests results given in this chapter should be understood as follows:

Table 3. Surge test result definition

Results	Details
OK	The EUT is still operating and able to communicate after the surge test, as required by EN50065-2-x.
KO	The EUT is NOT operating and/or able to communicate after the surge test.

The results, listed by TVS type used and surge level applied, are reported in the following table.

Table 4. Surge test report

TVS		Test results	
Primary side	Receiver side	±4 kV level	±6 kV level
SM6T15CA ⁽¹⁾	SM6T6V8CA ⁽¹⁾	OK	OK
SMA6J13CA	SMAJ5.0CA	OK	OK
SMAJ13CA	SMAJ5.0CA	OK	OK

1. EVALKITST7580-1 original configuration

Based on EN50065-2-3 requirement, it appears that all tested products can protect the PLM circuitry.

Note that all primary side and receiver side TVS have been chosen to provide the same actual clamp voltage as in the original EVALKITST7580-1 configuration. This is evident by comparing the datasheet values.

The following oscilloscope screenshots show a comparison of residual disturbance level and duration on the two most sensitive points of the PLC coupling circuit, i.e. the transmitted signal output (PA_OUT) and the received signal input (RX_IN), using both original TVS and alternative TVS part numbers.

The measurements prove that all the TVS types give equivalent protection to the PLC device.

Figure 9. PA_OUT waveform with SM6T15CA

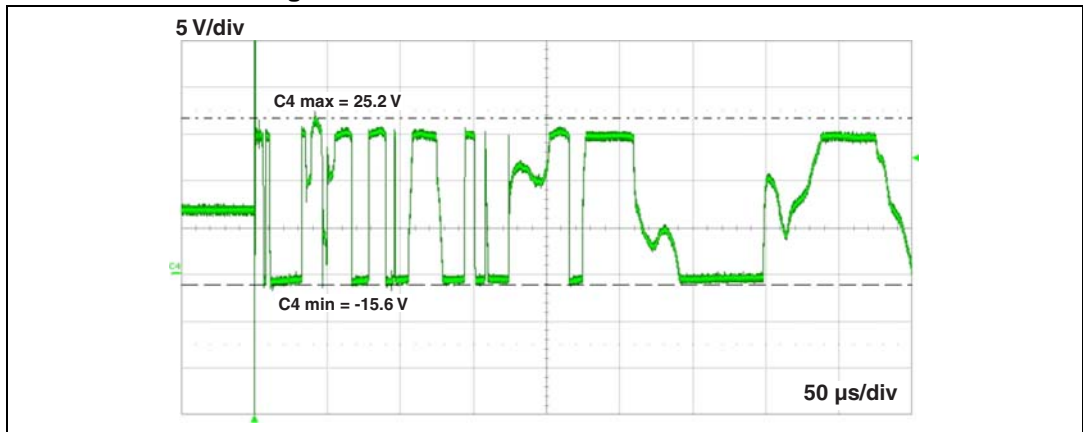

Figure 10. PA_OUT waveform with SMAJ13CA

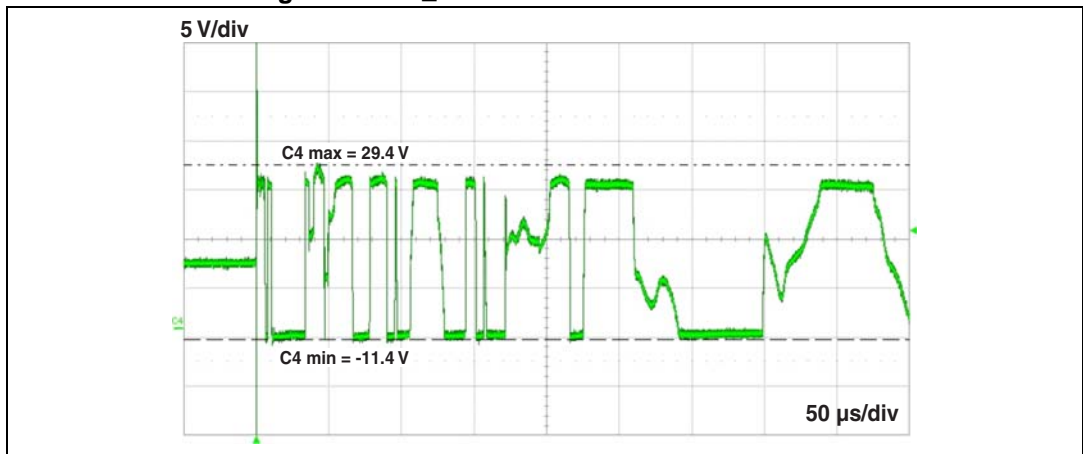

Figure 11. RX_IN waveform with SM6T6V8CA

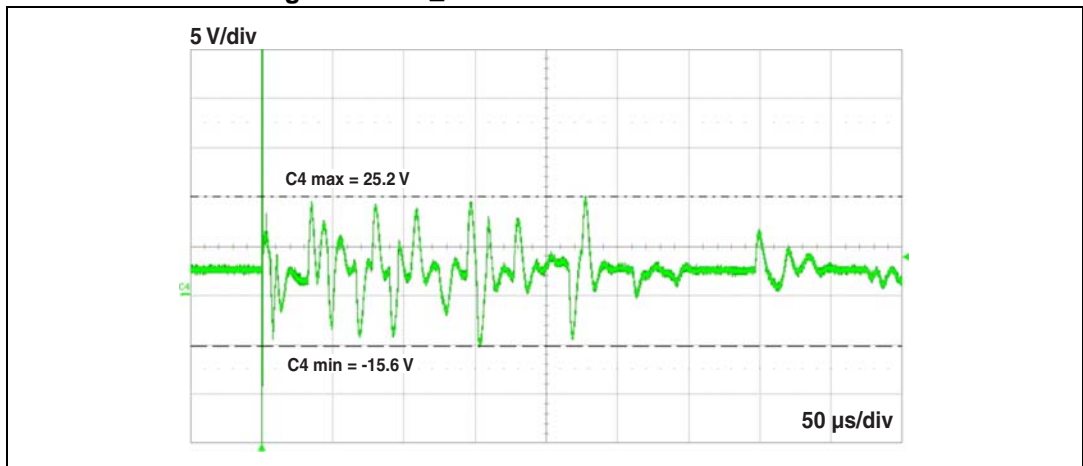
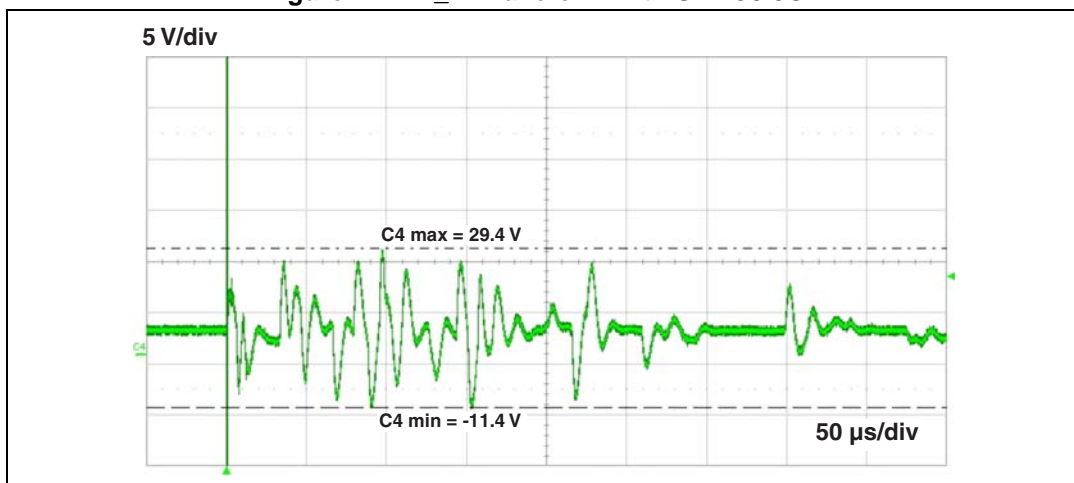

Figure 12. RX_IN waveform with SMAJ5.0CA



4 Primary side TVS validation through power rating

In order to guarantee reliability of the primary side protection TVS, an additional verification should be performed. Current as well as voltage across the protection device during surge should be measured and compared against the datasheet specifications.

In order to verify the exact power to be managed by the TVS, measured voltage and current across the TVS during differential surge are reported.

Figure 13. Measured current across the primary TVS during differential surge (1 V = 1 A)

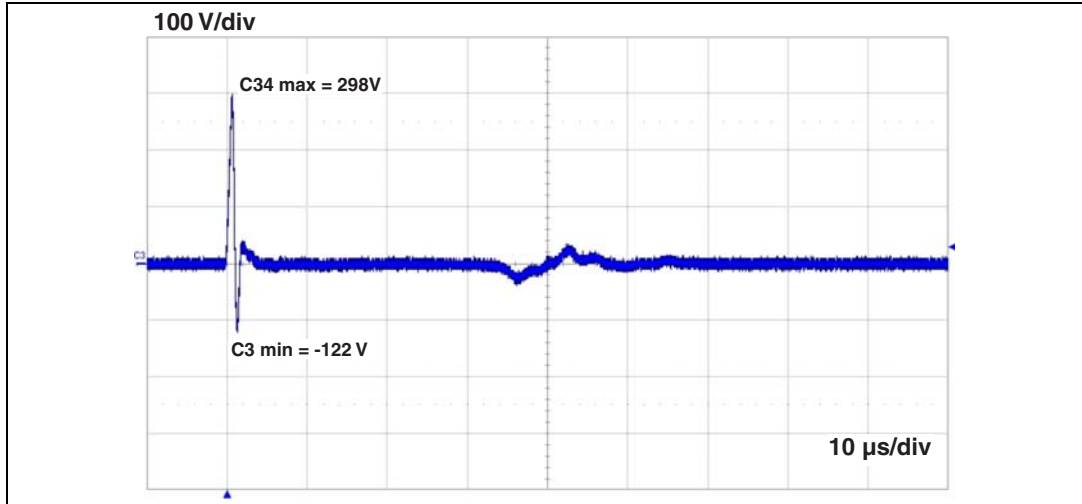
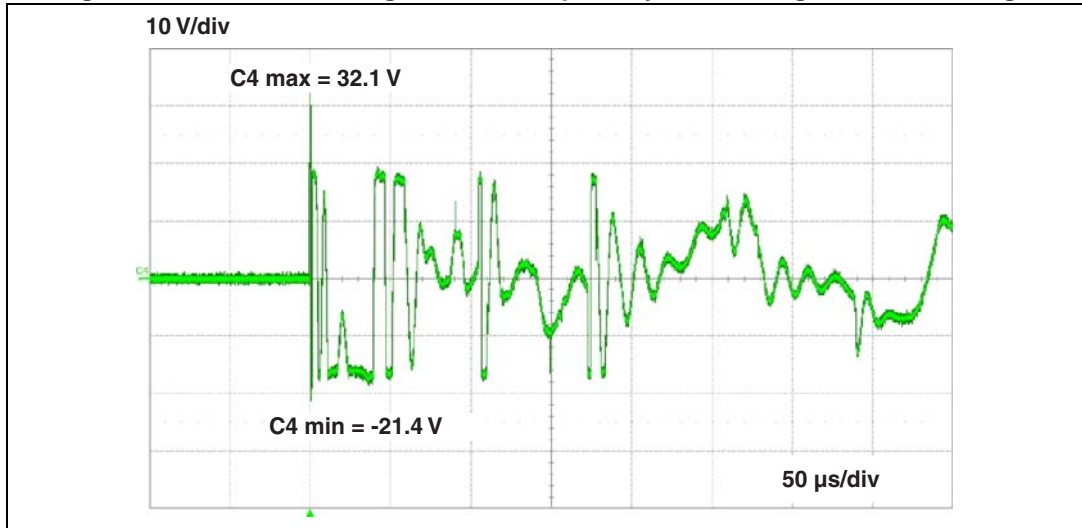

Figure 14. Measured voltage across the primary TVS during differential surge



Indeed, most of the power is already absorbed by the MOV as first-stage protection.

The residual surge left after the MOV has a peak current I_{PEAK} around 300 A and lasts about 1 μ s. The measured peak voltage V_{PEAK} is above 32 V. Therefore, the peak power across the TVS during the surge can be estimated as $P_{PEAK} = 32 \text{ V} \times 300 \text{ A} = 9.6 \text{ kW}$.

Now that the residual surge has been defined, it can be compared with the various TVS part number datasheets.

4.1 **SMAJ13CA**

In the SMAJ13CA datasheet, the Peak Pulse Power versus exponential pulse duration is provided. According to this parameter, a pulse lasting 1 μ s can be withstood if its power is lower than 9 kW.

This limit is exceeded by the previously measured PPEAK. Therefore, the SMAJ13CA TVS could be considered suitable for 4 kV level compliance only.

4.2 **SMA6J13CA**

In the SMA6J13CA datasheet, the Peak Pulse Power versus exponential pulse duration is provided. According to this parameter, a pulse lasting 1 μ s can be withstood if its power is lower than 11 kW.

This power capability is higher than the requirement set by the measurements above. Therefore, it is safe to use SMA6J13CA TVS up to 6 kV surge level.

4.3 **SM6T15CA**

The SM6T15CA TVS has the same power rating as the SMA6J13CA, so the same conclusions described above shall apply.

5 Conclusions

A detailed description of surge test setup, measurements, and results has been provided to verify compliance to international EMC standards.

The analyzed coupling circuit topology proved well devised to protect the PLC device. The right TVS part numbers were found and accurately tested.

Following these criteria to develop a PLC application will ensure reliability of the solution.

6 Revision history

Table 5. Document revision history

Date	Revision	Changes
15-Jan-2013	1	Initial release.
30-Jun-2014	2	Updated Figure 2 , Figure 3 and Chapter 4.2 .

Please Read Carefully:

Information in this document is provided solely in connection with ST products. STMicroelectronics NV and its subsidiaries ("ST") reserve the right to make changes, corrections, modifications or improvements, to this document, and the products and services described herein at any time, without notice.

All ST products are sold pursuant to ST's terms and conditions of sale.

Purchasers are solely responsible for the choice, selection and use of the ST products and services described herein, and ST assumes no liability whatsoever relating to the choice, selection or use of the ST products and services described herein.

No license, express or implied, by estoppel or otherwise, to any intellectual property rights is granted under this document. If any part of this document refers to any third party products or services it shall not be deemed a license grant by ST for the use of such third party products or services, or any intellectual property contained therein or considered as a warranty covering the use in any manner whatsoever of such third party products or services or any intellectual property contained therein.

UNLESS OTHERWISE SET FORTH IN ST'S TERMS AND CONDITIONS OF SALE ST DISCLAIMS ANY EXPRESS OR IMPLIED WARRANTY WITH RESPECT TO THE USE AND/OR SALE OF ST PRODUCTS INCLUDING WITHOUT LIMITATION IMPLIED WARRANTIES OF MERCHANTABILITY, FITNESS FOR A PARTICULAR PURPOSE (AND THEIR EQUIVALENTS UNDER THE LAWS OF ANY JURISDICTION), OR INFRINGEMENT OF ANY PATENT, COPYRIGHT OR OTHER INTELLECTUAL PROPERTY RIGHT.

ST PRODUCTS ARE NOT DESIGNED OR AUTHORIZED FOR USE IN: (A) SAFETY CRITICAL APPLICATIONS SUCH AS LIFE SUPPORTING, ACTIVE IMPLANTED DEVICES OR SYSTEMS WITH PRODUCT FUNCTIONAL SAFETY REQUIREMENTS; (B) AERONAUTIC APPLICATIONS; (C) AUTOMOTIVE APPLICATIONS OR ENVIRONMENTS, AND/OR (D) AEROSPACE APPLICATIONS OR ENVIRONMENTS. WHERE ST PRODUCTS ARE NOT DESIGNED FOR SUCH USE, THE PURCHASER SHALL USE PRODUCTS AT PURCHASER'S SOLE RISK, EVEN IF ST HAS BEEN INFORMED IN WRITING OF SUCH USAGE, UNLESS A PRODUCT IS EXPRESSLY DESIGNATED BY ST AS BEING INTENDED FOR "AUTOMOTIVE, AUTOMOTIVE SAFETY OR MEDICAL" INDUSTRY DOMAINS ACCORDING TO ST PRODUCT DESIGN SPECIFICATIONS. PRODUCTS FORMALLY ESCC, QML OR JAN QUALIFIED ARE DEEMED SUITABLE FOR USE IN AEROSPACE BY THE CORRESPONDING GOVERNMENTAL AGENCY.

Resale of ST products with provisions different from the statements and/or technical features set forth in this document shall immediately void any warranty granted by ST for the ST product or service described herein and shall not create or extend in any manner whatsoever, any liability of ST.

ST and the ST logo are trademarks or registered trademarks of ST in various countries.

Information in this document supersedes and replaces all information previously supplied.

The ST logo is a registered trademark of STMicroelectronics. All other names are the property of their respective owners.

© 2014 STMicroelectronics - All rights reserved

STMicroelectronics group of companies

Australia - Belgium - Brazil - Canada - China - Czech Republic - Finland - France - Germany - Hong Kong - India - Israel - Italy - Japan - Malaysia - Malta - Morocco - Philippines - Singapore - Spain - Sweden - Switzerland - United Kingdom - United States of America

www.st.com