**Guidelines for designing touch sensing applications
with projected sensors**

Introduction

This application note describes the layout and mechanical design guidelines used for touch sensing applications with projected sensors.

This document describes only what is specifically related to projected sensors, designed using STM8L52/L53 microcontrollers. To have general tips and tricks for designing touch application, please refer to AN4312.

Table 1 lists the microcontrollers concerned by this application note.

Table 1. Applicable products

Type	Applicable products
Microcontrollers	STM8TL52/L53 lines

Contents

- 1 Technology Overview 4**
- 2 Projected sensor design 5**
 - 2.1 Touchkey sensor 5
 - 2.1.1 Diamond type sensor 5
 - 2.1.2 H sensor single layer 6
 - 2.1.3 H type sensor two layers 7
 - 2.2 Linear sensor 8
 - 2.3 Rotary sensor 9
 - 2.4 Specific recommendations 10
 - 2.4.1 PCB and layout 10
- 3 Conclusion 13**
- 4 Revision history 14**

List of figures

Figure 1. Electric field between 2 surface electrodes 5
Figure 2. Diamond implementation 6
Figure 3. H sensor (single layer) 7
Figure 4. Two-layer implementation. 8
Figure 5. Normal linear sensor. 9
Figure 6. Small linear sensor 9
Figure 7. Rotary sensor made of 5 parcels 10
Figure 8. Ground floods around Tx 11
Figure 9. Potential false key detection 12

1 Technology Overview

STMicroelectronics offers capacitive sensing technology. This technology is based on:

- The projected acquisition principle with STM8TL5x microcontrollers.

An overview of how it works: a capacitor is modified when the finger gets close to a sensor. The finger changes the dielectric properties.

The sensor consists of two electrodes:

- Tx driven by a port in output mode,
- Rx in the return path to a dedicated port in read mode.

There is a sampling capacitor which stores the charges coming from the electrodes which form a coupling capacitor with less capacitance than the sample one. When a finger approaches, the dielectric (between the two electrodes) is modified and so the capacitance decreases. As a consequence, the time taken to load the sample capacitor will increase and this difference is used to detect if a finger is present or not.

2 Projected sensor design

2.1 Touchkey sensor

The touchkey sensor can be of any shape, however it is recommended to use a square as this shape is the simplest. The touch sensing library and ProxSense™ IP automatically compensate for capacitance differences, but the acquisition time and processing parameters can be optimized if the sensors have a similar capacitance. For this reason, it is recommended to use the same shape for all sensors.

The physical principle for a touchkey, linear or rotary sensor is that an electric field surrounds the Tx and Rx electrodes (see [Figure 1](#)). This field is dependent on the permittivity ϵ_R of both the front panel and the PCB. It should not be dependent on air bubbles or moisture which can be trapped between them, because they must be sufficiently well bonded by the adhesive.

Figure 1. Electric field between 2 surface electrodes

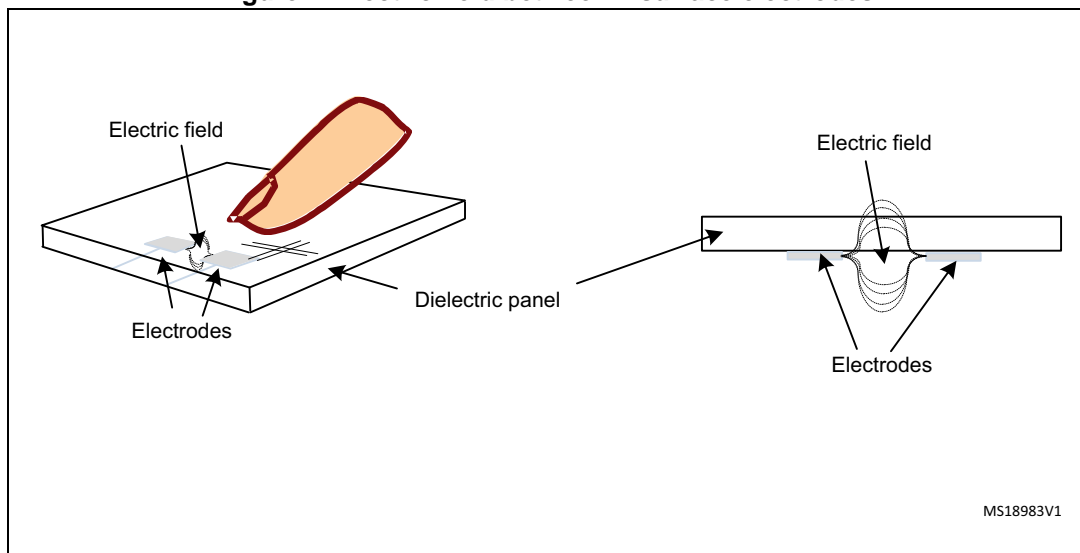

1. The above figure only shows a simplified representation of the sensor; for specification details, refer to [Figure 2](#) to [Figure 4](#).

Hence, the sensitivity is dependent on known materials and is optimized. This will ensure that the disturbance caused by the user's finger is detected and measured with accuracy.

It is recommended to define the sensor size in relation to the panel thickness (d) and vice-versa. The following formula helps the designer to define the external size of touchkey sensors (L), and also for linear touch sensor and rotary touch sensor parcels:

$$L \text{ (mm)} = 3 + (1.75 * d)$$

For example, a typical 10*10 mm touchkey should be used with a 4 mm Plexiglas panel.

2.1.1 Diamond type sensor

In this "diamond type" implementation, the Tx and Rx electrodes form a diamond shape where the two electrodes are on the same layer, using a bridge (see [Figure 2](#)).

Note: This symmetrical implementation allows swapping Rx & Tx.

Figure 2. Diamond implementation

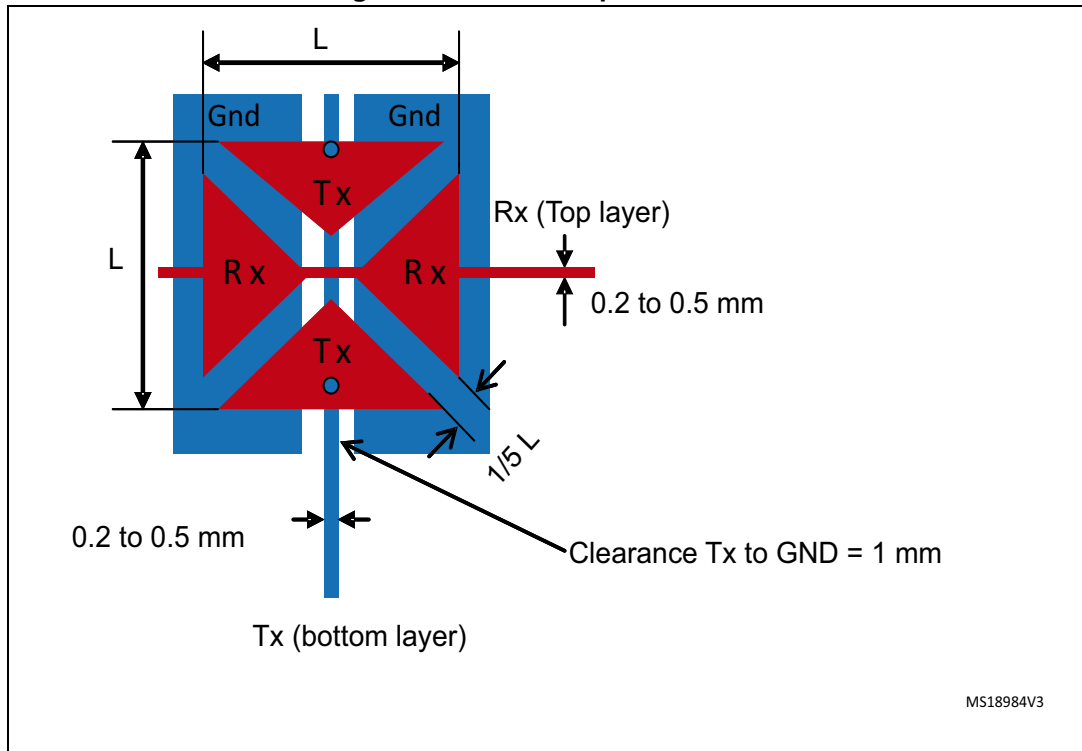

MS18984V3

2.1.2 H sensor single layer

In this implementation, Tx is on the top layer and forms two rectangles face to face with a gap between them. The Rx electrode is a wire on the top layer, in the middle of the Tx gap (see [Figure 3](#)).

Figure 3. H sensor (single layer)

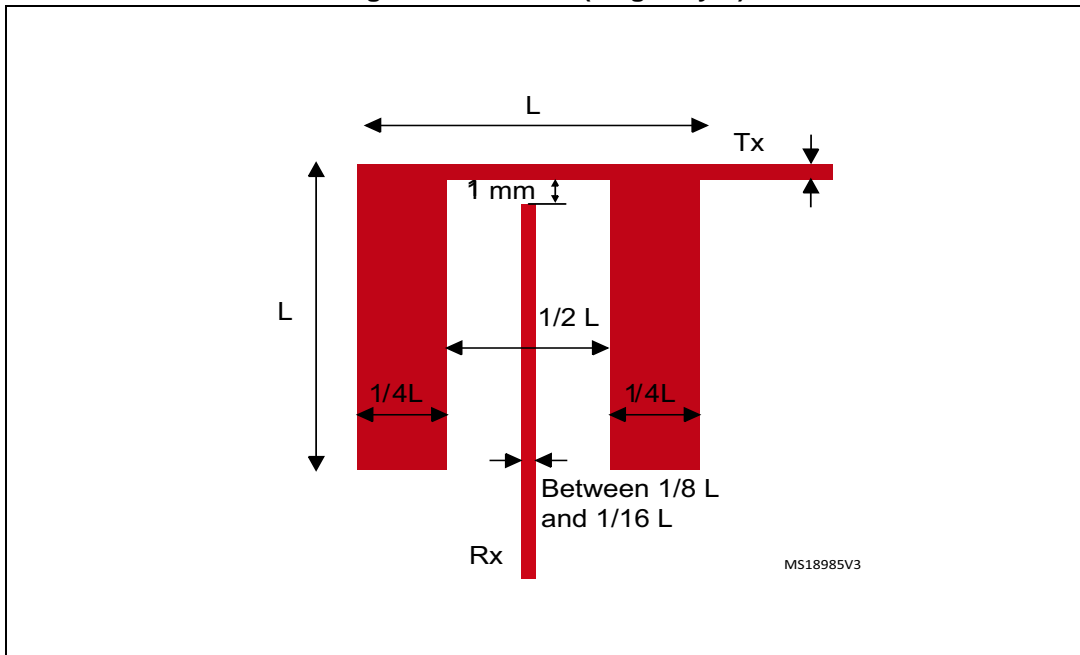

2.1.3 H type sensor two layers

In this implementation, the Tx electrode forms an H, and the Rx electrode is a wire which lies on the Tx square. There is an isolating material between them, and Tx square electrode is hollow under the Rx electrode (see [Figure 4](#)). Obviously, this kind of touchkey is made of two layers.

Figure 4. Two-layer implementation

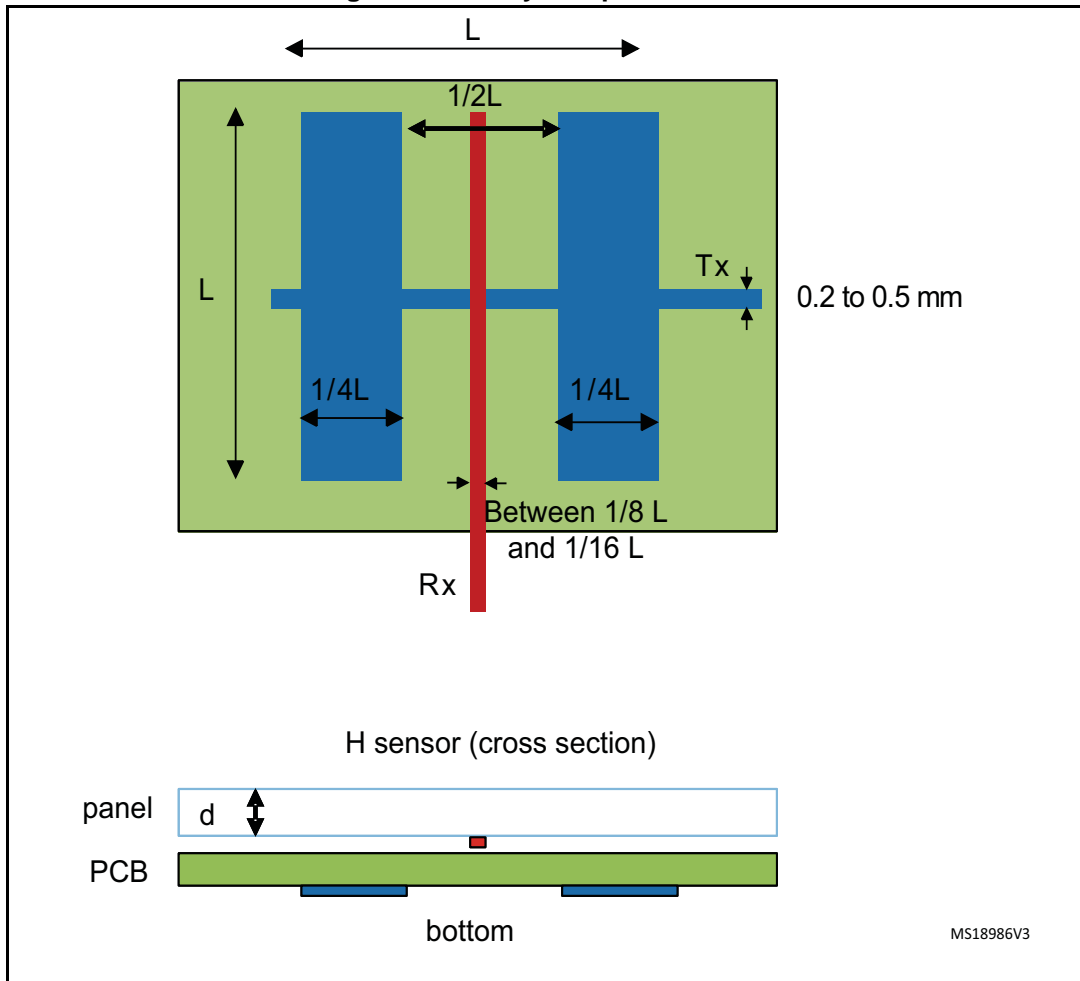

2.2 Linear sensor

An example of a linear sensor with five parcels is described in [Figure 5](#). This kind of linear touch sensor is fine when each parcel is about 6 mm to 10 mm and it could have N parcels. So, for an overall length L, you can calculate the parcel number: $N = L / \text{parcel size}$ (adjust the parcel size to obtain N as an integer).

Figure 5. Normal linear sensor

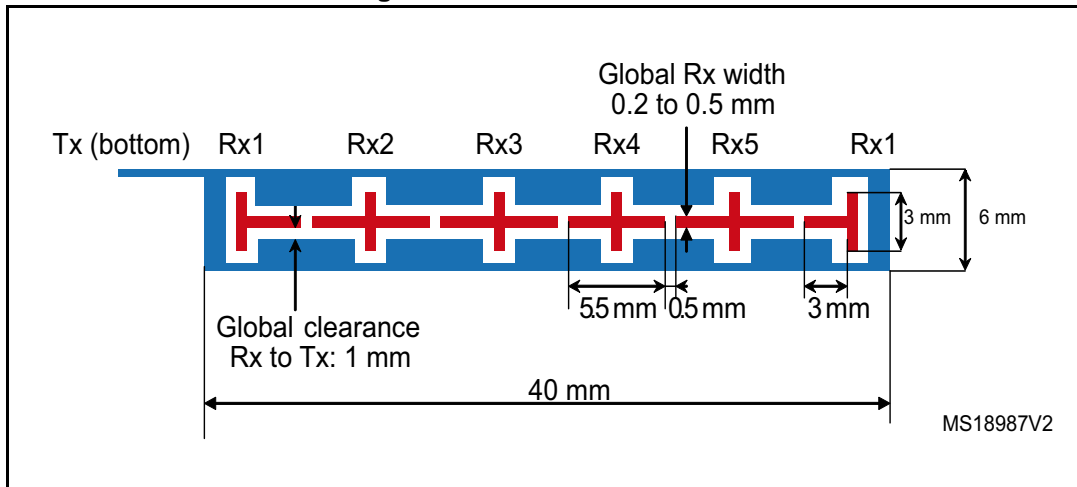

For smaller linear touch sensors under 6 mm, you can use an H sensor placed side by side (with same size rules as H touchkey) (see [Figure 6](#)).

Figure 6. Small linear sensor

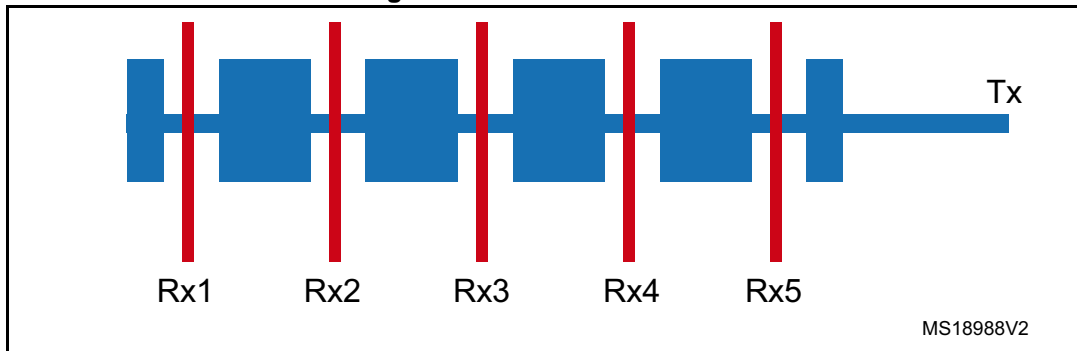

2.3 Rotary sensor

The design of rotary sensor with the projected technology is very similar to a linear sensor one, so the recommended sizes for a parcel are the same (see [Figure 7](#)). You can design rotary sensors with a diameter of 12 mm to 30 mm having a minimum of 5 parcels.

Figure 7. Rotary sensor made of 5 parcels

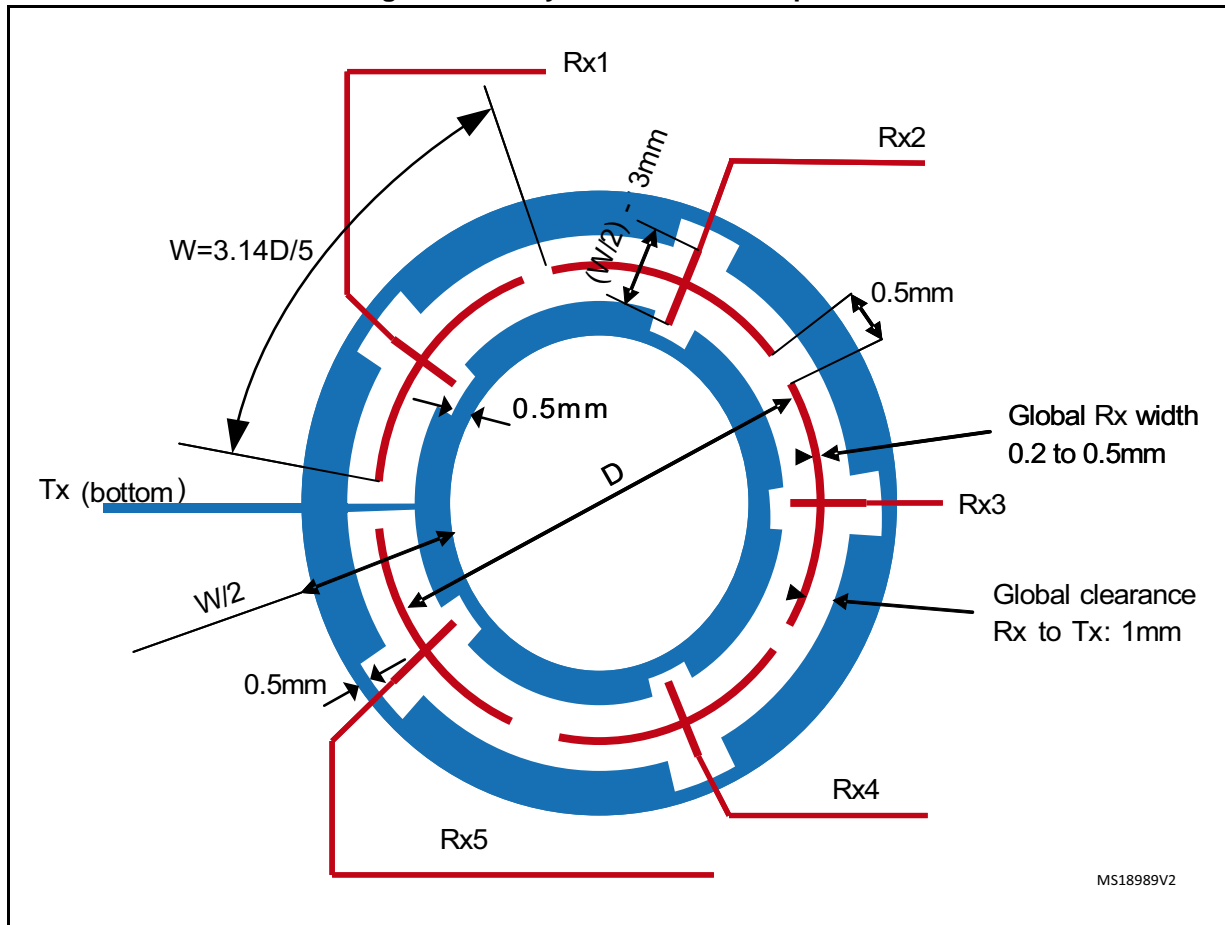

To design the rotary sensor:

1. Define the diameter (D) of the rotary sensor (12 mm to 30 mm) and the number of parcels (N minimum = 5)
2. Verify the outer arc (W) of each parcel in the rotary sensor; it should be from 6 to 10 mm
3. If necessary, adjust the parcel number by using the following formula: $N = 3.14 * D / W$ (with W chosen between 6 and 10 mm to obtain N as an integer)

2.4 Specific recommendations

2.4.1 PCB and layout

Ground considerations

One of the advantages of a projected sensor compared to a surface sensor is that its Tx and Rx signals are less sensitive to the external environment than the ones used with the surface sensor because they are coupled together. Rx is impacted by the ground in any case (but less than the surface sensor); on the other hand, Tx is shielded by the ground. So the sensor can be flooded as shown in [Figure 8](#).

Figure 8. Ground floods around Tx

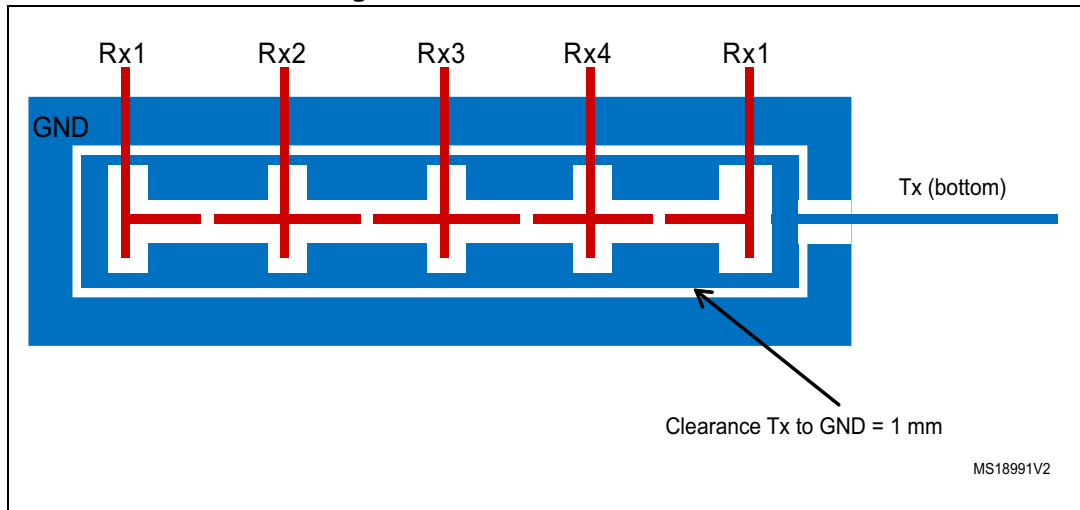

Ground plane at the bottom is recommended to:

- prevent false detection from the back side
- shield Rx track from Tx one
- increase the sensitivity
- improve the directivity

For water immunity, avoid ground plane at top layer, and reduce it at the bottom by using hatched plane.

Tx routing

To route the Tx signal efficiently, the most important thing to respect and almost the only one is the RC time constant rule. But keep in mind that signals which switch rapidly (more than tens of kHz) such as high speed communication signals, LCD or LED drive signals must be routed far away from Tx.

The Tx track is less sensitive than the Rx track so it can be put on any layer of the PCB but Rx tracks should be considered when routing it to ensure a good design.

Rx routing

On the other hand, the Rx track is very sensitive due to the capacitance of the sensor. A false detection may occur if some guidelines are not followed. The most obvious is to route it far from the sensor itself, e.g. on another layer.

Another one is to avoid placing ground near the Rx track which reduces the sensitivity.

Then, when Rx and Tx are very close (about less than 10 mm), an electric field is also generated and a finger which roams here can generate a false touchkey detection (see [Figure 9](#)).

Figure 9. Potential false key detection

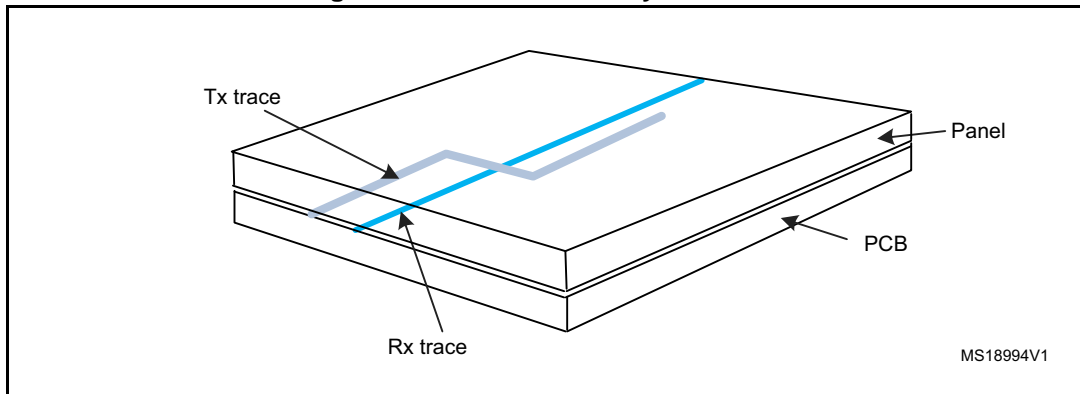

Avoiding false detection

Follow these recommendations to avoid false touchkey detection:

- The Tx and Rx tracks should never cross each other; but if they do, it must be at a right angle.
- When the Rx and Tx tracks go in the same direction and to places that are close together, it is better to separate them with a ground which has to be more than twice the width of each signal track.
- To further reduce the coupling between the Tx and Rx tracks, the Tx signal can run under the ground, in this case even if Rx is near the ground, coupling should not happen.
- If the Rx track is behind the Tx track from a user point of view, the user cannot modify the electrical field. Obviously, if Rx and Tx signals are too far apart, there will be no interaction.

Furthermore, you can consider these general guidelines:

- The Tx and Rx tracks must be as thin as possible.
- The Rx tracks must be as far as possible from the touchkey.
- When there are several touchkeys, it is better to keep all the Tx tracks together and all the Rx tracks together, which greatly reduces any false touchkey detection.

3 Conclusion

The projected sensors can be used for designing touch sensing application and great cares must be given to the design guideline described in this document such as reduce the ground coupling or track dimensions. In other cases, issues can remain so only to test deeply can validate the system.

4 Revision history

Table 2. Document revision history

Date	Revision	Changes
27-Nov-2013	1	Initial release.

Please Read Carefully:

Information in this document is provided solely in connection with ST products. STMicroelectronics NV and its subsidiaries ("ST") reserve the right to make changes, corrections, modifications or improvements, to this document, and the products and services described herein at any time, without notice.

All ST products are sold pursuant to ST's terms and conditions of sale.

Purchasers are solely responsible for the choice, selection and use of the ST products and services described herein, and ST assumes no liability whatsoever relating to the choice, selection or use of the ST products and services described herein.

No license, express or implied, by estoppel or otherwise, to any intellectual property rights is granted under this document. If any part of this document refers to any third party products or services it shall not be deemed a license grant by ST for the use of such third party products or services, or any intellectual property contained therein or considered as a warranty covering the use in any manner whatsoever of such third party products or services or any intellectual property contained therein.

UNLESS OTHERWISE SET FORTH IN ST'S TERMS AND CONDITIONS OF SALE ST DISCLAIMS ANY EXPRESS OR IMPLIED WARRANTY WITH RESPECT TO THE USE AND/OR SALE OF ST PRODUCTS INCLUDING WITHOUT LIMITATION IMPLIED WARRANTIES OF MERCHANTABILITY, FITNESS FOR A PARTICULAR PURPOSE (AND THEIR EQUIVALENTS UNDER THE LAWS OF ANY JURISDICTION), OR INFRINGEMENT OF ANY PATENT, COPYRIGHT OR OTHER INTELLECTUAL PROPERTY RIGHT.

ST PRODUCTS ARE NOT AUTHORIZED FOR USE IN WEAPONS. NOR ARE ST PRODUCTS DESIGNED OR AUTHORIZED FOR USE IN: (A) SAFETY CRITICAL APPLICATIONS SUCH AS LIFE SUPPORTING, ACTIVE IMPLANTED DEVICES OR SYSTEMS WITH PRODUCT FUNCTIONAL SAFETY REQUIREMENTS; (B) AERONAUTIC APPLICATIONS; (C) AUTOMOTIVE APPLICATIONS OR ENVIRONMENTS, AND/OR (D) AEROSPACE APPLICATIONS OR ENVIRONMENTS. WHERE ST PRODUCTS ARE NOT DESIGNED FOR SUCH USE, THE PURCHASER SHALL USE PRODUCTS AT PURCHASER'S SOLE RISK, EVEN IF ST HAS BEEN INFORMED IN WRITING OF SUCH USAGE, UNLESS A PRODUCT IS EXPRESSLY DESIGNATED BY ST AS BEING INTENDED FOR "AUTOMOTIVE, AUTOMOTIVE SAFETY OR MEDICAL" INDUSTRY DOMAINS ACCORDING TO ST PRODUCT DESIGN SPECIFICATIONS. PRODUCTS FORMALLY ESCC, QML OR JAN QUALIFIED ARE DEEMED SUITABLE FOR USE IN AEROSPACE BY THE CORRESPONDING GOVERNMENTAL AGENCY.

Resale of ST products with provisions different from the statements and/or technical features set forth in this document shall immediately void any warranty granted by ST for the ST product or service described herein and shall not create or extend in any manner whatsoever, any liability of ST.

ST and the ST logo are trademarks or registered trademarks of ST in various countries.

Information in this document supersedes and replaces all information previously supplied.

The ST logo is a registered trademark of STMicroelectronics. All other names are the property of their respective owners.

© 2013 STMicroelectronics - All rights reserved

STMicroelectronics group of companies

Australia - Belgium - Brazil - Canada - China - Czech Republic - Finland - France - Germany - Hong Kong - India - Israel - Italy - Japan - Malaysia - Malta - Morocco - Philippines - Singapore - Spain - Sweden - Switzerland - United Kingdom - United States of America

www.st.com

