



---

## Introduction to USB hardware and PCB guidelines using STM32 MCUs

### Introduction

STM32 microcontrollers include a group of products embedding a USB (universal serial bus) peripheral (see the table below for applicable products). Full-speed and high-speed operations are provided through embedded and/or external PHYs (physical layers of the open system interconnection model).

This application note gives an overview of the USB peripherals implemented on STM32 MCUs. It also provides hardware guidelines for PCB design, to ensure electrical compliance with the USB standards.

For more details, refer to the USB or OTG sections in the product reference manual.

**Table 1. Applicable products**

Type	Series, lines, part numbers <sup>(1)</sup>
Microcontrollers	STM32F2 series
	STM32F4 series <sup>(2)</sup>
	STM32F7 series
	STM32H5 series
	STM32H7 series
	STM32F0 series <sup>(3)</sup>
	STM32F1 series <sup>(4)</sup>
	STM32F302 line
	STM32F303xD/xE/xB/xC products
	STM32F373 line
	STM32G0B0xx products
	STM32G0C1xx products
	STM32G4 series
	STM32C071 line
	STM32L0 series <sup>(5)</sup>
	STM32L1 series
	STM32L4 series <sup>(6)</sup>
	STM32L4+ series
	STM32L5 series
	STM32U073 line
	STM32U083 line
	STM32U5 series
	STM32U3 series
	STM32WBA2x line
	STM32WBA6x line
STM32WB35xx products	
STM32WB55xx products	
STM32N6 series	

1. Check the product datasheet for supported part numbers.
2. STM32F410 is not supported.
3. STM32F030, STM32F0x1, STM32F038, STM32F098, and STM32F058 are not supported.
4. STM32F100 and STM32F101 are not supported.
5. STM32L0x0 is not supported.
6. STM32L4x1 is not supported.

## 1 General information

This document applies to STM32 microcontrollers which are based on Arm® cores.



*Note: Arm is a registered trademark of Arm Limited (or its subsidiaries or affiliates) in the US and/or elsewhere. The Arm word and logo are trademarks of Arm Limited (or its subsidiaries) in the US and/or elsewhere. All rights reserved.*

**Table 2. Abbreviations and acronyms**

Acronym	Description
ADP	Attach detection protocol
BCD	Battery charging detection
EMI	Electromagnetic interference
ESD	Electrostatic discharge
FS	Full-speed
HBM	Human body model
HS	High-speed
IEC	International electrotechnical commission
LPM	Link power management
LS	Low-speed
MCU	Microcontroller unit or microcontroller
OTG	On-the-go
PCB	Printed circuit board
PHY	Physical layer
SOF	Start of frame
ULPI	UTMI + low-pin interface
USB	Universal Serial Bus
UTMI	USB 2.0 transceiver macrocell interface

### References

- System Level ESD-expanded, JEDEC, September 2013.
- Improve System ESD Protection While Lowering On-Chip ESD Protection, [www.mobiledevdesign.com](http://www.mobiledevdesign.com), February 2009.
- USB 2.0 specification, revision 2.0, April 2000, available at [www.usb.org](http://www.usb.org).
- On The Go and Embedded Host Supplement to the USB revision 2.0 specification, revision 2.0, July 2012 available at [www.usb.org](http://www.usb.org).
- High Speed USB Platform Design Guidelines, available at [www.usb.org](http://www.usb.org).

## 2 USB on STM32 products

### 2.1 USB implementation on STM32 products

**Table 3. USB implementation on STM32 mainstream products**

Feature <sup>(1)</sup>	STM32F070x6/B	STM32F072 STM32F078 STM32F04x	STM32F102 STM32F103	STM32F105/107	STM32F302xB/C STM32F303xB/C STM32F373	STM32F302x6/8 STM32F302xD/E STM32F303xD/E	STM32C071	STM32G0B0xx STM32G0C1xx	STM32G4
	USB 2.0 FS device interface			USB OTG_FS	USB 2.0 FS device interface		USB 2.0 FS host/device interface		USB 2.0 FS device interface
Crystal-less USB	-	X	-	-	-		Supported in device mode	-	X
Bidirectional endpoints (including EP0)	8			4	8		8	8	8
Host mode channels	-			8	-		8	8	-
Size of dedicated packet buffer SRAM	1 Kbyte <sup>(2)</sup>		512 bytes <sup>(3)</sup>	1.25 Kbytes <sup>(4)</sup>	512 bytes <sup>(4)</sup>	1 Kbyte <sup>(2)</sup>	2 Kbytes	2 Kbytes	1 Kbyte
Integrated PHY	FS <sup>(5)</sup>		FS <sup>(5)</sup>	FS <sup>(5)</sup>	FS <sup>(5)</sup>		FS <sup>(5)</sup>	FS <sup>(5)</sup>	FS <sup>(5)</sup>
Pull-up resistor on USB_DP line	Embedded		1.5 kΩ resistor must be added	Embedded	1.5 kΩ resistor must be added		Embedded	Embedded	Embedded
LPM	X	-			X		Supported in device mode	Supported in device mode	X
BCD	X	-			-		Supported in device mode	Supported in device mode	X
ADP	-			-		-		-	X

1. X: supported.
2. When the CAN peripheral is used, only the first 768 bytes are available to the USB. The last 256 bytes are used by the CAN.
3. The USB and CAN share a dedicated 512 bytes SRAM. They can then be used in the same application but not at the same time.
4. The dedicated SRAM is used exclusively by the USB endpoints (not shared with any other peripheral).
5. Internal FS OTG PHY support.



Table 4. USB implementation on STM32 high-performance products

Feature <sup>(1)</sup>	STM32F401 STM32F411		STM32F2x5 STM32F2x7 STM32F405 STM32F415 STM32F407 STM32F417 STM32F427 STM32F437 STM32F429 STM32F439		STM32F412 STM32F413 STM32F423		STM32F446 STM32F469 STM32F479 STM32F74x STM32F756 STM32F76x STM32F77x STM32F7x2 STM32F730R/V STM32F750		STM32F7x3 STM32F730Z/I		STM32H742 STM32H743 STM32H753 STM32H750 STM32H745 STM32H755 STM32H747 STM32H757		STM32H7A3 STM32H7B3 STM32H7B0 STM32H723 STM32H733 STM32H735 STM32H730		STM32H5F/E STM32H7R3x8 /R7x8 STM32H7S3x8/ S7x8 STM32H7S3x8/ S7x8 STM32H7R3x8 /R7x8		STM32C562 STM32H503 STM32H563 STM32H573 STM32H562		STM32N6
	OTG_FS	OTG_HS	OTG_FS	OTG_HS	OTG_FS	OTG_HS	OTG_FS	OTG_HS	OTG_FS	OTG_HS	OTG_FS	OTG_HS	OTG_HS	OTG_FS	OTG_HS	USB 2.0 FS host/device interface	OTG_HS		
Crystal-less USB	-	-	-	-	-	-	-	-	-	-	X	X	X	X	X	-	-		
Bidirectional endpoints (including EP0)	4	6	4	6	6	9	6	9	6	9	6	9	9	6	9	8	9		
Host mode channels	8	12	8	12	12	16	12	16	12	16	12	16	16	12	16	8 <sup>(2)</sup>	16		
Size of dedicated packet buffer SRAM (Kbytes) <sup>(3)</sup>	1.25	-	1.25	4	1.25	-	1.25	4	1.25	4	1.25	4	4	1.25	4	2	4		
Integrated PHY	FS <sup>(4)</sup>	FS <sup>(4)</sup>	FS <sup>(4)</sup>	FS <sup>(4)</sup>	FS <sup>(4)</sup>	FS <sup>(4)</sup>	FS <sup>(4)</sup>	FS <sup>(4)</sup>	FS <sup>(4)</sup>	HS <sup>(5)</sup>	FS <sup>(4)</sup>	FS <sup>(4)</sup>	FS <sup>(4)</sup>	FS <sup>(4)</sup>	HS <sup>(5)</sup>	FS <sup>(4)</sup>	HS <sup>(5)</sup>		
ULPI available to primary I/Os via multiplexing	-	-	-	X	-	-	-	X	-	-	-	-	-	-	-	-	-		
Dedicated VDDUSB	NO		YES		YES		YES		YES		YES		YES		YES		YES		
LPM	-	-	-	-	X	-	X	X	X	X	X	X	X	X	X	X	X		
BCD	-	-	-	-	X	-	-	-	X	-	X	X	X	X	X	X	X		
ADP	-	-	-	-	-	-	-	-	-	-	-	-	-	-	-	-	-		

1. X: supported.

2. Bi-directional (including EP0)

3. The dedicated SRAM is used exclusively by the USB endpoints (not shared with any other peripheral).

4. Internal FS OTG PHY support.
5. Internal HS OTG PHY support.

**Table 5. USB implementation on STM32 ultra-low-power products**

Feature <sup>(1)</sup>	STM32L0x2 STM32L0x3	STM32L1xx	STM32L4x2 STM32L4x3	STM32L4x5 STM32L4x6 STM32L4Rx STM32L4Sx	STM32L5	STM32U3	STM32U575 STM32U585	STM32U535 STM32U545	STM32U59x STM32U5Ax STM32U5Gx STM32U5Fx	STM32U073x8/B/ C STM32U083xC
	USB 2.0 FS device interface			USB OTG_FS	USB 2.0 FS device interface	USB 2.0 FS host/device interface	USB OTG_FS	USB 2.0 FS host/device interface	USB 2.0 OTG_HS	USB 2.0 FS device interface
Crystal-less USB	X	-	X	X <sup>(2)</sup>	X	X	X	X	X	X
Bidirectional endpoints (including EP0)	8			6	8	8	6	8	9	8
Host mode channels	-			12	-	8 <sup>(3)</sup>	12	8 <sup>(3)</sup>	16	-
Size of dedicated packet buffer SRAM <sup>(4)</sup>	1 Kbyte			1.25 Kbytes (with advanced FIFO control)	1 Kbyte	2 Kbytes	1.25 Kbytes	2 Kbytes	4 Kbytes	1 Kbyte
Integrated PHY	FS <sup>(5)</sup>			FS <sup>(5)</sup>	FS	FS	FS <sup>(5)</sup>	FS <sup>(5)</sup>	HS <sup>(5)</sup>	FS <sup>(5)</sup>
Pull up resistor on USB_DP line	X			X	X	X	X	X	X	X
Dedicated VDDUSB	YES	NO	YES	YES	YES	YES	YES	YES	YES	YES
LPM	X			X	X	X	X	X	X	X
BCD	X			X	X	X	X	X	X	X
ADP	-			X	-	-	-	-	-	-

1. X: supported.
2. Except for STM32L47x/L48x devices.
3. Bi-directional (including EP0)
4. The dedicated SRAM is used exclusively by the USB endpoints (not shared with any other peripheral).
5. Internal FS OTG PHY support.

**Table 6. USB implementation on STM32 wireless products**

Feature	STM32WB35xx/ STM32WB55xx	STM32WBA2x	STM32WBA6x
	USB 2.0 FS device interface	USB 2.0 FS host/device interface	USB 2.0 HS host/device interface
Crystal-less USB	X	-	-
Number of endpoints	8	8	9
Host mode channels	12	16	16
Size of dedicated packet buffer SRAM	1.25 Kbytes	2 Kbytes	4 Kbytes
Integrated PHY	FS	FS	HS
Pull up resistor on USB_DP line	X	X	X
LPM	X	X	X
BCD	X	X	X
ADP	-	-	-

## 2.2 Supported USB speeds

In Host mode, the USB OTG\_FS supports full- and low-speed transfers, while in device mode it only supports full-speed transfers.

**Table 7. Supported OTG\_FS speeds**

Mode <sup>(1)</sup>	FS (12 Mbit/s)	LS (1.5 Mbit/s)
Host	X	X
Device	X	-

1. X: supported.

In Host mode, the USB OTG\_HS supports high-, full-, and low-speed transfers, while in device mode, it only supports high- and full-speed transfers.

**Table 8. Supported OTG\_FS speeds**

Mode <sup>(1)</sup>	HS (480 Mbit/s)	FS (12 Mbit/s)	LS (1.5 Mbit/s)
Host	X	X	X
Device	X	X	-

1. X: supported.

## 2.3 Protection against ESD and EMI

Protection against ESD and EMI is needed. The system must comply with both the JESD22-A114D (also known as HBM) and the IEC 61000-4-2 standards.

The HBM requires that the USB pins of the component device be tolerant up to 2 kV discharge, this is the case for STM32 MCUs. Refer to the figure and the table below for JESD22-A114D standard test waveform and class levels. For more details, refer to the document *System Level ESD-expanded* available at [www.jedec.org](http://www.jedec.org).

**Figure 1. JESD22-A114D standard test waveform**

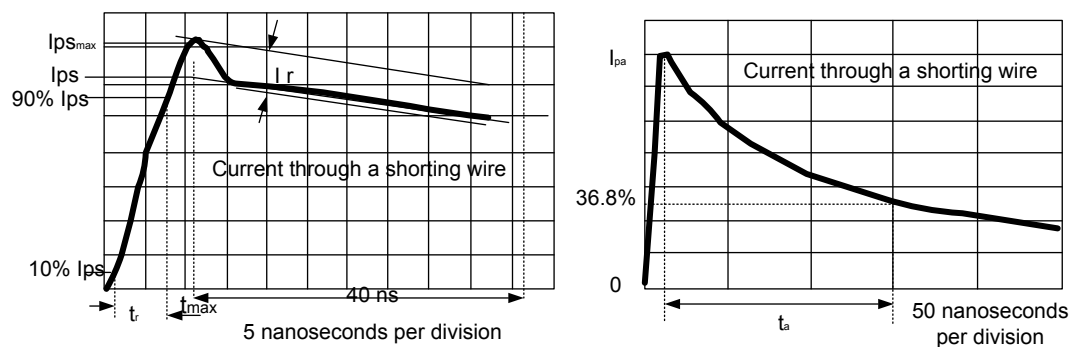
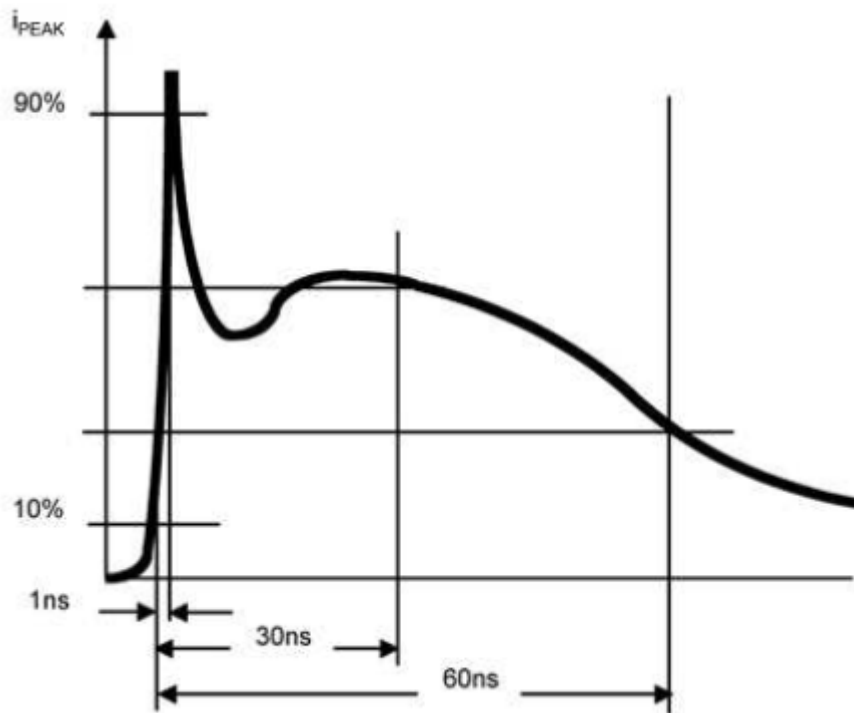

**Table 9. JESD22-A114D standard class levels**

Class	Voltage range	Current range
Class 0	$V < 250 \text{ V}$	$I < 0.17 \text{ A}$
Class 1A	$250 \text{ V} < V < 500 \text{ V}$	$0.17 \text{ A} < I < 0.33 \text{ A}$
Class 1B	$500 \text{ V} < V < 1000 \text{ V}$	$0.33 \text{ A} < I < 0.67 \text{ A}$
Class 1C	$1 \text{ kV} < V < 2 \text{ kV}$	$0.67 \text{ A} < I < 1.33 \text{ A}$
Class 2	$2 \text{ kV} < V < 4 \text{ kV}$	$1.33 \text{ A} < I < 2.67 \text{ A}$
Class 3A	$1 \text{ kV} < V < 8 \text{ kV}$	$2.67 \text{ A} < I < 5.33 \text{ A}$
Class 3B	$V > 8 \text{ kV}$	$I > 5.33 \text{ A}$

The system must also comply with the IEC 61000-4-2 standard on USB lines when they are connected to a receptacle. This standard is fairly different from the HBM standard. Refer to the image and the table below for IEC 61000-4-2 standard test waveform and class levels.

**Figure 2. IEC 61000-4-2 standard waveform**



**Table 10. IEC 61000-4-2 standard class levels**

Level	Contact	Air	Peak current (A)
	Indicated voltage (kV)		
1	2	3	7.5
2	4	4	15
3	6	8	22.5
4	8	15	30

To see the difference between the current pulses applied in the two tests, compare the two figures presented above.

To improve the protection against high ESD surges (and then to meet the conditions requested by the standards), dedicated components have to be placed as close as possible to the receptacle (see the table below).

**Table 11. ESD protection**

Interface	Protection	
	Low price	Low area on PCB
USB FS	USBLC6-2SC6 (+ ESDA7P60-1U1M for VBUS)	USBLC6-2P6 (+ ESDA7P60-1U1M for VBUS)
USB FS OTG	USBLC6-4SC6	DSILC6-4P6
USB HS	ECMF02-2AMX6 (+ ESDA7P60-1U1M for 5 V VBUS)	
USB HS OTG ECMF02	ECMF02-2AMX6 (+ ESDA7P60-1U1M for 5 V VBUS + ESDALC6V1-1U2 for ID)	

## 2.4 Clock

The FS USB device/OTG requires a precise 48 MHz clock. This frequency can be generated from the internal main PLL, or by the internal 48 MHz oscillator.

In the first case, the clock source must use an HSE crystal oscillator, in the second case, the synchronization for the oscillator can be taken from:

- The USB data stream itself (SOF signalization), no external resonator/ crystal is needed (this feature is only available for devices embedding a crystal-less USB 2.0 FS device interface), or
- The internal 48 MHz oscillator trimmed on LSE (not accurate enough for a USB host).
- MSI and LSE only for STM32L47x/L48x devices.

If HS operation is required, the OTG PHY is connected to the microcontroller ULPI port through 12 signals. It can be clocked using the 60 MHz output (provided from the HS PHY: HSE is not mandatory in this case).

As stated on the following figure, for STM32F7x3xx devices the USB HS PHY includes two embedded PLLs:

- PLL1: has as clock source the HSE clock. The supported values are: 12, 12.5, 16, 24 and 25 MHz. The PLL1 outputs the 60 MHz used as input for the PLL2.
- PLL2: outputs the high speed (480 MHz) clock.

**Figure 3. HS PHY PLLs on STM32F7x3 devices**

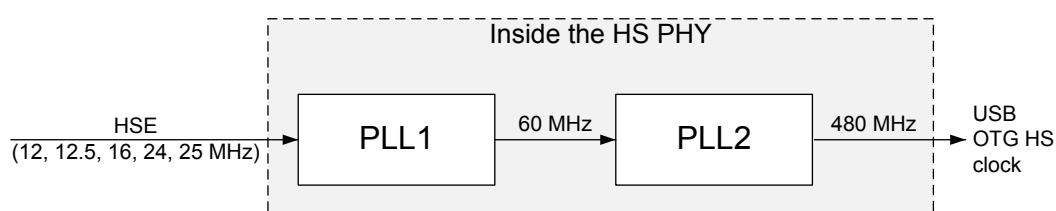

*Note:* The AHB frequency has to be higher than 14.2 MHz to guarantee a correct operation for the USB OTG\_FS peripheral, and higher than 30 MHz for the USB OTG\_HS peripheral.

## 2.5 Power

For USB transceivers, the operating voltage ranges between 3.0 and 3.6 V. This voltage is obtained from one of the following:

- $V_{DD}$ : standard external power supply for the STM32MCU I/Os
- $V_{DDUSB}$ : a dedicated independent power supply for USB. This power supply can be connected either to  $V_{DD}$  or to an external independent power supply for USB transceivers.

Consequently, the microcontroller can be powered with the minimum specified supply voltage, while an independent power supply 3.3 V can be connected to  $V_{DDUSB}$ .

When the  $V_{DDUSB}$  is connected to a separated power supply, it is independent from  $V_{DD}$  or  $V_{DDA}$ , but it must be the last supply to be provided and the first to be removed.

Some important points to notice are listed below:

- The USB full-speed transceiver functionality is ensured down to 2.7 V. The USB full-speed electrical characteristics are degraded when  $V_{DD}$  ranges between 2.7 and 3.0 V
- $V_{DDUSB}$  is not available on all STM32 devices. Refer to the "Dedicated VDDUSB" column in [Section 2: USB on STM32 products](#) to check whether this feature is available on a specific MCU.
- The  $V_{DDUSB}$  pin must be connected to two external decoupling capacitors (100 nF ceramic + 1  $\mu$ F tantalum or ceramic)
- Some devices, when in high-pin-count packages, feature a dedicated VDDUSB pin. When assembled in low-pin-count packages, these devices have only the VDD pin to ensure the USB functionality.
- On STM32F7x3xx devices, the USB HS PHY subsystem uses an additional power supply pin: VDD12OTGHS pin is the output of the HS PHY regulator (1.2 V). An external capacitor (2.2  $\mu$ F) must be connected to the VDD12OTGHS pin.
- On STM32H7x3 devices,  $V_{DD50USB}$  can be supplied through the USB cable to generate the  $V_{DD33USB}$  via a USB internal regulator. This is used to support a  $V_{DD}$  supply different from 3.3 V. The USB regulator can be bypassed to supply  $V_{DD33USB}$  directly when  $V_{DD} = 3.3$  V.

*Note:* Refer to AN5419, 'Getting Started with STM32H723/733, STM32H725/735, and STM32H730 Value Line Hardware Development,' for more details about the STM32H7 power supply configuration in USB.

## 2.6 VBUS sensing detection

Based on the USB specification, a USB device must use VBUS sensing detection. When the device detects the host presence, it connects its pull-up resistor to either a D+ or D- data signal. This allows the host to detect the device presence on the bus.

There are two cases:

- The USB device is bus-powered. VBUS sensing is not mandatory (USB is always connected when the device is powered)
- The device is self-powered. VBUS sensing is mandatory.

Pin PA9, a five volt-tolerant pin, which includes an additional function natively dedicated to VBUS sensing. The absolute maximum ratings table of the datasheet indicates that the five volt-tolerant pin voltage cannot exceed  $V_{DD} + 4$  V. The user must avoid the situation when the MCU is not powered, and a 5 V VBUS is connected to PA9: this violates the condition on absolute maximum ratings, and can result in permanent damage to the device. For this purpose, it is mandatory to reduce the voltage on PA9 below 4 V.

For a reliable and safe VBUS detection, the use of a voltage divider is recommended to guarantee absolute maximum ratings.

### 2.6.1 Simple resistor divider

To minimize the DC current, the total resistance between VBUS and GND must be high. The basic GPIO input levels ( $V_{IL}$ ,  $V_{IH}$ ) can now be used with the resistor divider. As this method uses the regular GPIO functionality, the VBUS sensing function (OTG\_GCCFG.VBDEN), embedded in PA9, should not be enabled.

The GPIOs available in STM32 families exhibit varying maximum operating conditions at their inputs. These conditions are typically restricted to a value that depends on certain VDDs. For instance, the expression  $\min(V_{DD}, V_{DDA}, V_{DD3V3\_USB}, V_{BAT}) + 3.9$  represents one such example. To detect VBUS through GPIOs, it is imperative to adhere to these tolerances even in the absence of VDDs. In the worst-case scenario (that is, absence of all VDDs), the aforementioned expression would yield a value of 3.9 V. This higher tolerance enables easier detection. However, if the guaranteed input tolerance is less than 3.6 V, a different approach is required.

*Note:* For the  $V_{IL}/V_{IH}$  calculation, all GPIOs are powered by the main I/O supply  $V_{DD}$ . The  $V_{DDUSB}$  is dedicated in some MCUs to the USB signals.

The recommended resistor divider values for VBUS detection are the following:

- For  $V_{DD}$  in the 3.0-3.6 V range: 82 k $\Omega$  (to GND), 33 k $\Omega$  (to VBUS).
- For  $V_{DD}$  in the 1.65-2.0 V range: 68 k $\Omega$  (to GND), 82 k $\Omega$  (to VBUS).

Resistor values have been assessed assuming a  $\pm 1\%$  tolerance. They are checked against  $V_{IL}/V_{IH}$  across the different STM32 families, to guarantee switching when  $V_{BUS}$  is between 0.8 and 3.67 V.

Note: This solution works well as long as GPIO maximum operating conditions are  $\geq VDD + 3.6 V$

Figure 4. Simple resistor divider

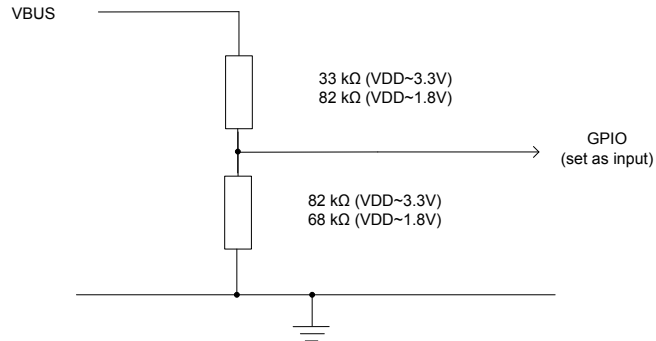

DTT75003V1

It is also possible to use only three resistors with a solder bridge as shown in Figure 5.

Figure 5. Resistor divider supporting both 1.8 and 3.3V ranges

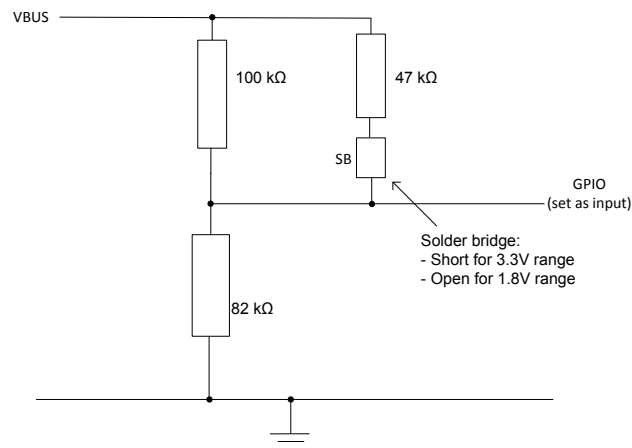

DTT75004V2

### 2.6.2 MOSFET detector

When the GPIO input tolerance is lower, a simple resistor divider is no longer electrically compatible. A simple and cheap way to detect VBUS presence in this case is to resort to an N-channel MOSFET, the recommended device is a 2N7002. Note that this scheme inverts the detection compared with a resistor divider (low level when VBUS is present). See Figure 6 below.

Note: This solution is recommended when GPIO maximum operating conditions are  $< VDD + 3.6 V$

Figure 6. VBUS detection when GPIO max

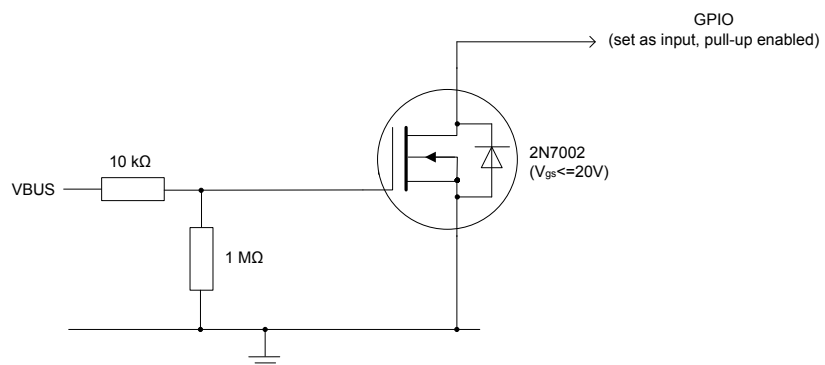

DTT75008V1

## 3 Hardware guidelines for USB implementation

This section describes the hardware requirements for correct operation of the USB peripheral.

### 3.1 USB FS upstream port

In peripheral mode, the  $V_{BUS}$  power is always provided through the cable. The USB FS impedance driver is always managed internally to avoid the need to add external serial resistors on the data line path.

According to the USB specification, there are two main use cases:

- Self-powered applications: platforms providing their own power supply and acting as an upstream port on the cable insertion. Not allowed, under any condition, to draw any current from the USB interface.
- Bus-powered applications: a platform supplied only through VBUS and acting as an upstream port.

#### 3.1.1 USB FS upstream port in self-powered applications

To optimize the power consumption on self-powered platforms, only a USB PHY and a controller must be started on the VBUS detection.

It is recommended to implement a resistor bridge (refer to [Section 2.6](#) for more details). It is also recommended to use an ESD protection device and to place it as close as possible to the USB connector.

To be compliant with the USB 2.0 full-speed electrical specification, the USB\_DP (D+) pin must be pulled up with a 1.5 k $\Omega$  resistor to a voltage in the 3.0 to 3.6 V range.

In several STM32 MCUs, the pull-up resistor is already implemented. The user must add this resistor in other STM32 MCUs (refer to the 'Embedded pull-up resistor on USB\_DP line' column in [Section 2](#)).

*Note:*

*Since OTG\_HS PHY hardware internally behaves similarly for VBUS sensing, the same external resistor approach applies. The difference between FS and HS PHY is basically in data signaling speed, not in VBUS detection logic.*

**Figure 7. USB FS upstream port with embedded pull-up resistor in self-powered applications**

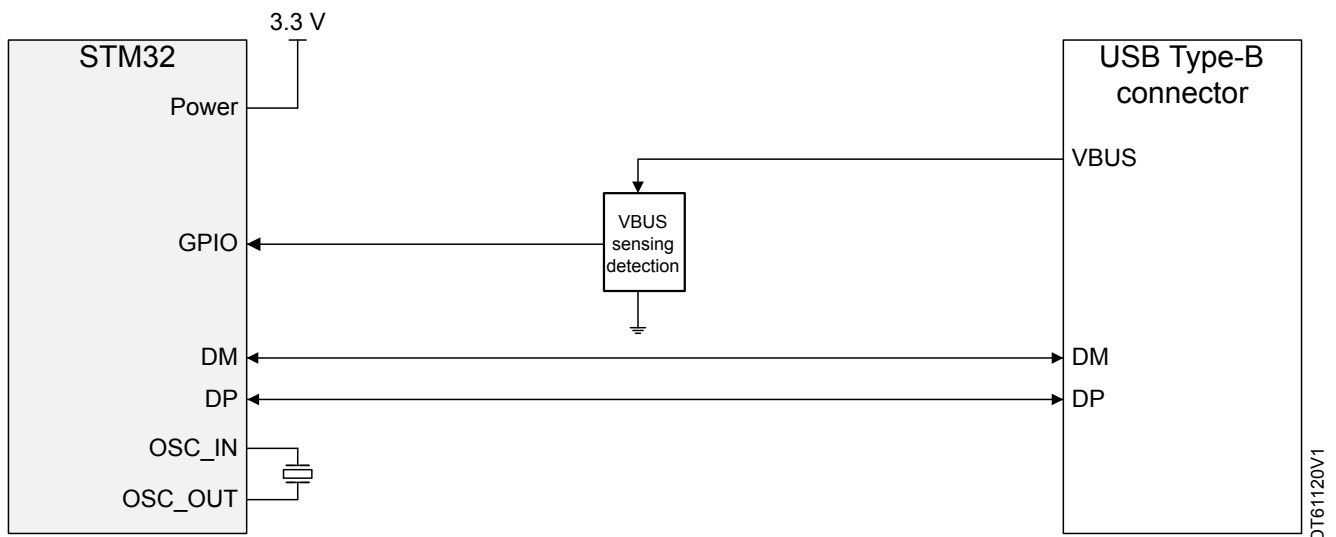

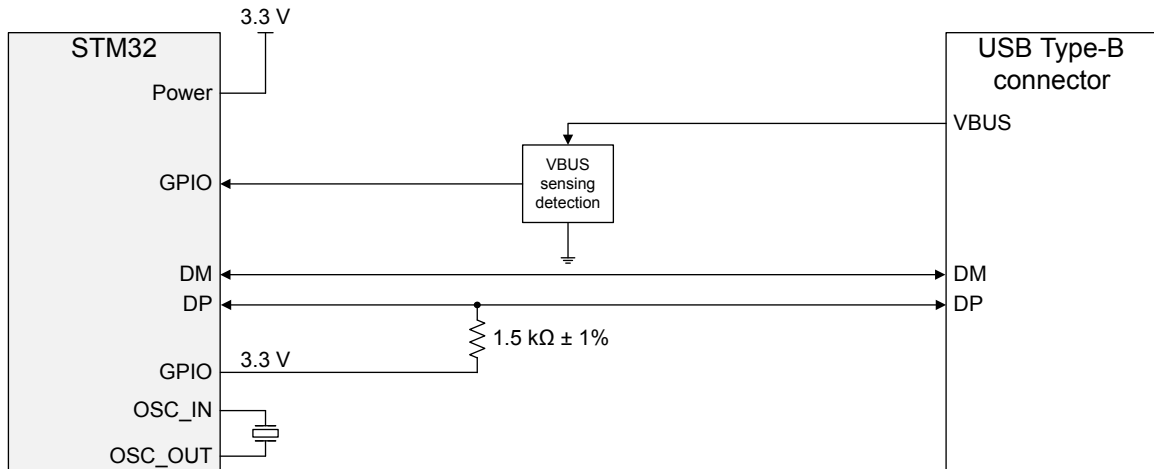
**Figure 8. USB FS upstream port without embedded pull-up resistor in self-powered applications**

DT61121V3

A DP pull-up must be connected only when VBUS is plugged. A GPIO from the MCU is used to drive it after the VBUS detection.

### 3.1.2 USB FS upstream port in bus-powered applications

A bus-powered application is an application where the supply comes exclusively from VBUS. In order to keep the host alive and the VBUS available, both the PHY and the controller must always be active.

It is recommended to use an external low-dropout regulator (LDO) to lower the input supply of the MCU (LDO39050PU33R or an equivalent component can be used), and to place the ESD protection chip (if used) as close as possible to the USB connector.

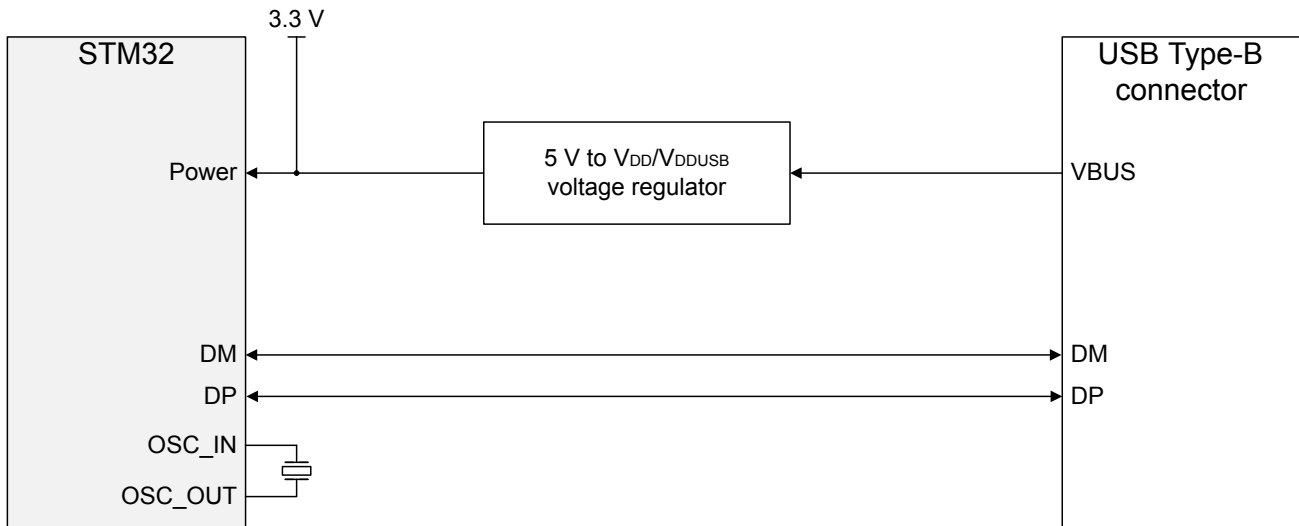
**Figure 9. USB FS upstream port with embedded pull-up resistor in bus-powered applications**

DT61122V1

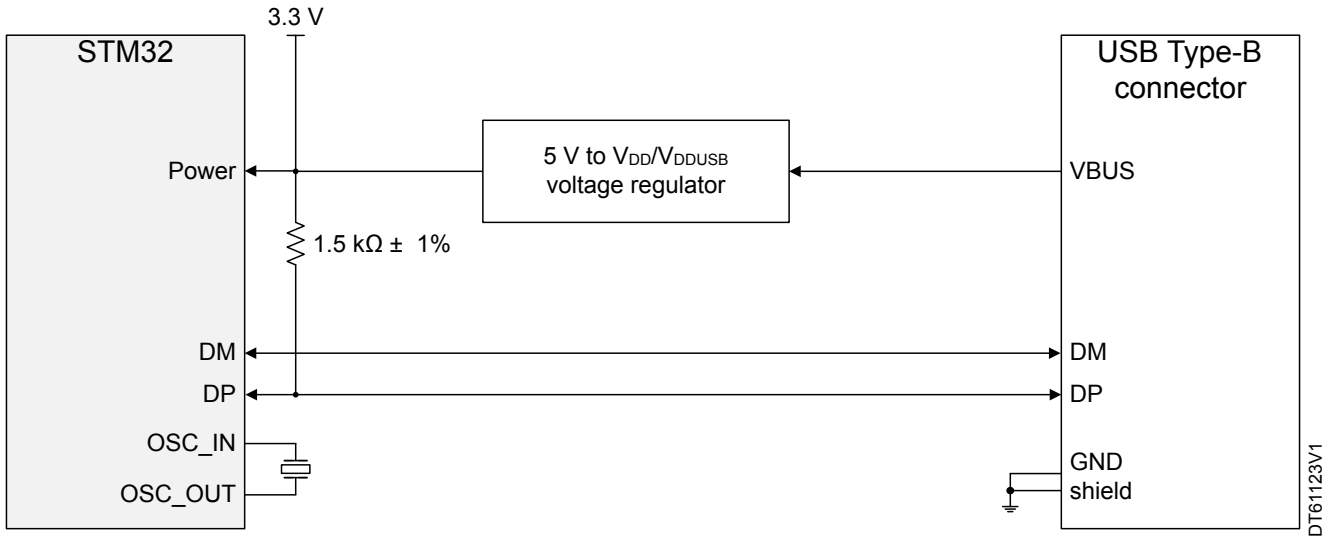
**Figure 10. USB FS upstream port without embedded pull-up resistor in bus-powered applications**

### 3.2 USB FS downstream port

This section describes the implementation for the USB FS downstream port, available on all the STM32 microcontrollers supporting host connection.

As required by the USB specification, if a VBUS overload occurs, it must be indicated to the user. The information regarding a VBUS overload is provided to the STM32 device via a switch with overcurrent protection (STMP2151STR or equivalent), as shown in the figure below.

The ESD protection chip, if used, has to be placed as close as possible to the USB connector.

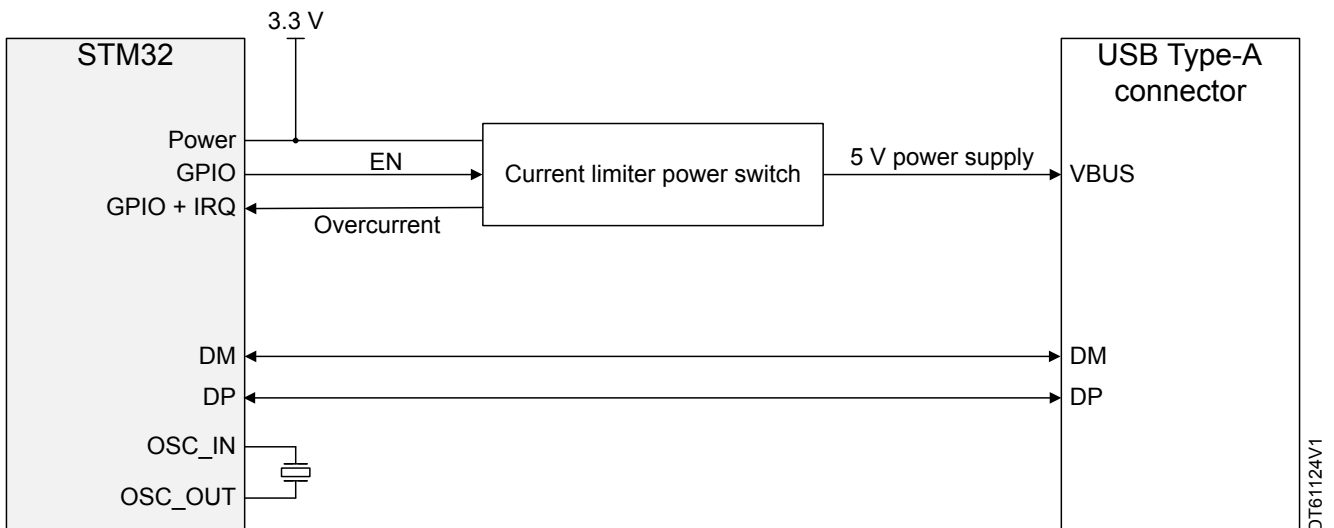
**Figure 11. USB FS downstream implementation**

### 3.3 OTG applications through embedded PHY

The USB OTG products address scenarios that allow portable devices and non-PC hosts to have the following enhancements:

- targeted host capability to communicate with a list of selected USB peripherals
- support for direct connections between OTG devices
- power saving features to preserve battery life
- a new pin on a connector, named ID, identifies the USB power role

Consequently, the OTG platforms must include:

- an STM32 MCU supporting the OTG feature
- a Micro-AB connector: the USB role is identified through the ID pin
- a VBUS generation when the OTG device acts as a downstream facing port
- a VBUS current overflow, both monitoring and acting as a downstream facing port

Regarding the figure that is presented below:

- The OTG specification requires the use of a capacitor (maximum value 4.7  $\mu$ F) on VBUS.
- The ESD protection chip, if used, must be placed as close as possible to the USB connector.
- A power switch (such as STMPS2151STR) is required.
- When an overcurrent is detected, the information is sent to the STM32 software, which alerts the user about the issue (it is recommended to route VBUS far from DP/DM).
- The STM32 must always be supplied when the platform is connected as device to a host (in case of dead battery support, the voltage on PA9 must be reduced as explained in [Section 2.6](#)).

**Figure 12. OTG schematic implementation (dual-mode)**

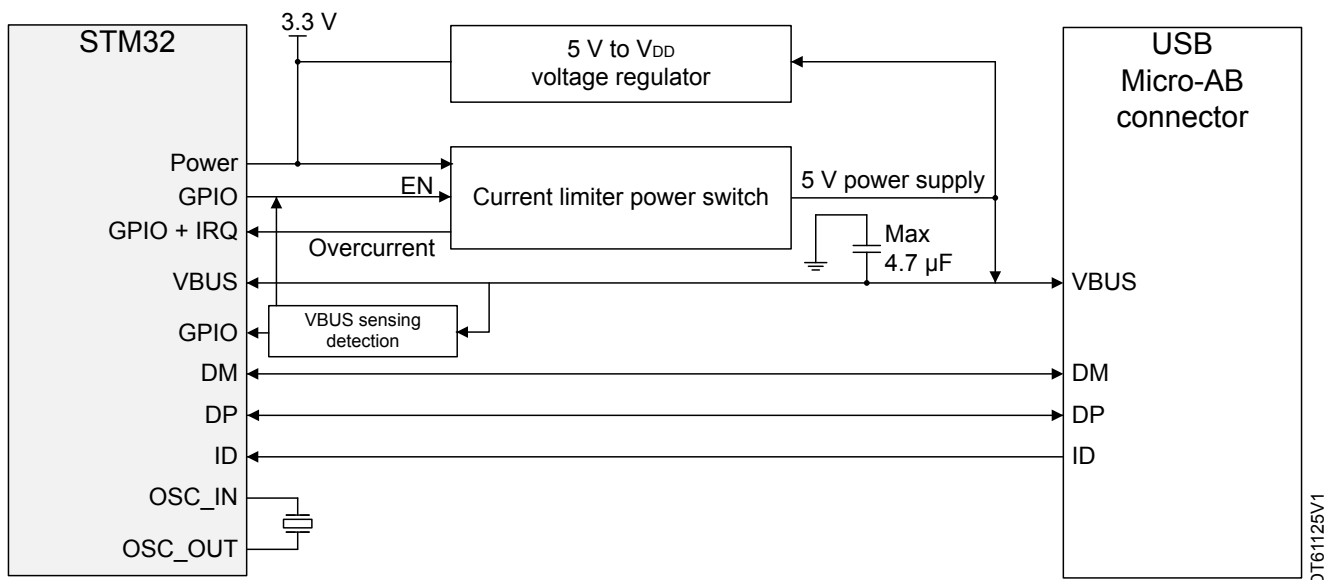

Additional considerations:

- An external voltage regulator is only needed when building a VBUS powered device.
- The current limiter is required only if the application has to support a VBUS powered device. A basic power switch can be used if 5 V supply is available on the application board.
- The ID pin is required in dual role only.
- The same application can be developed using the OTG\_HS in FS mode to achieve enhanced performance thanks to the large Rx/Tx FIFO and to a dedicated DMA controller.

### 3.4 OTG\_HS PHY connected through ULPI

The USB standards propose routing guidelines for high-speed USB platforms in the *High Speed USB Platform Design Guidelines* document available on the USB-IF website.

**Note:** For a full-speed driver that is part of a high-speed driver, the impedance is  $45 \Omega \pm 10\%$ .

**Recommendations:**

- Because the ULPI PHY is the controller of an ULPI CLK, a crystal oscillator is required to guarantee clock precision for the ULPI sampling and for the USB HS data sampling.
- The OTG specification requires a capacitor (maximum value 4.7  $\mu$ F) on VBUS.
- The ESD protection chip, if used, has to be placed as close as possible to the USB connector.

*Note:* The ULPI protocol allows automatic communication of system events, for example detection of Vbus presence. The OTG\_HS controller has a bit to indicate a new session (SRQINT = 1).

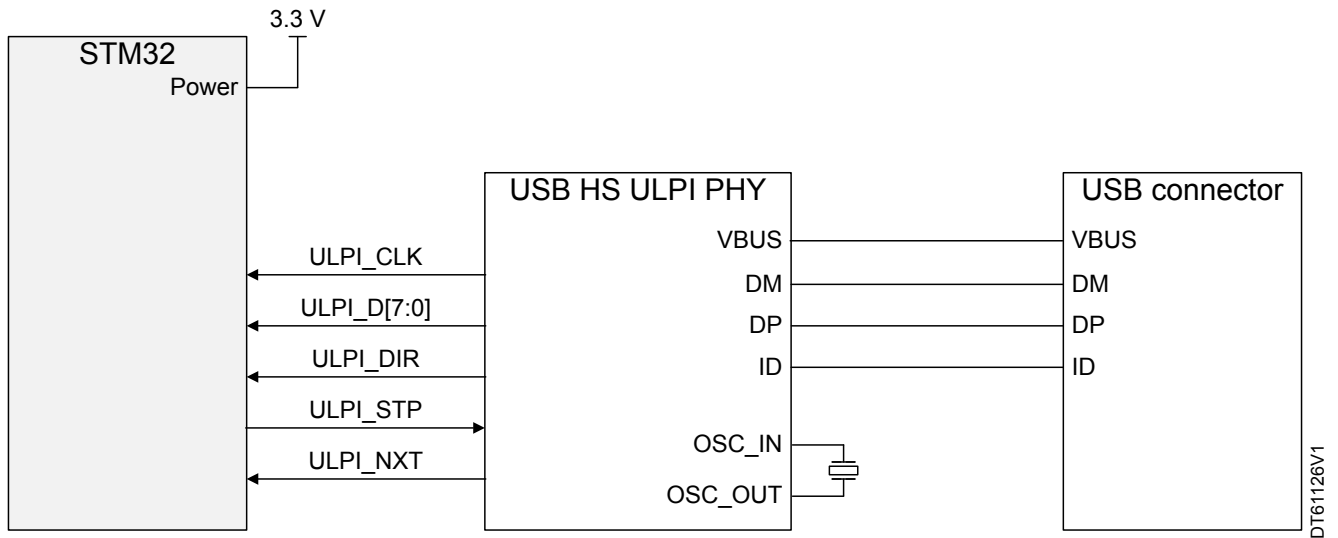
**Figure 13. USB HS via ULPI interface**

### 3.4.1 External USB HS PHYs compatible via ULPI interface

The following table lists some external USB HS PHYs compatible through the ULPI interface.

**Table 12. Compatible USB HS PHY**

USB HS PHY	Tested on	
	Board	MCU
ISP1705AET	STM3240G-EVAL	STM32F407
	STM3241G-Eval	STM32F417
	STM3221G-Eval	STM32F207
	STM3220G-EVAL	STM32F217
USB3300-EZK	STM32779I-Eval	STM32F777
	STM32769I-Eval	STM32F769
	STM32756G-EVAL	STM32F756
	STM32746G-Eval	STM32F746
	STM32479I-Eval	STM32F479
	STM32F446E-Eval	STM32F446
	STM32F439I-Eval	STM32F439
	STM32F429I-Eval	STM32F429
USB3320C-EZK	STM32H753I-EVAL	STM32H753
	STM32H743I-EVAL	STM32H743
	STM32F769I-DISCO	STM32F769
	STM32F746G-DISCO	STM32F746

### 3.5 USB applications through the embedded OTG\_HS PHY

To operate USB HS on STM32F7x3 devices there is no need to connect an external HS PHY via ULPI, as they already include an internal HS USB PHY.

There are some other recommendations in addition to those detailed for the embedded USB FS PHY:

- An external capacitor of 2.2  $\mu$ F must be connected on the VDD12OTGHS pin.
- The HS PHY has an OTG\_HS\_REXT pin needed for calibration. This pin must be connected to GND via an external precision resistor (3 K $\Omega$   $\pm$  1%).

### 3.6 STM32 on USB-IF integrators list

The list of the STM32 devices with certified USB peripherals is available on [www.usb.org](http://www.usb.org). The table below summarizes the certified USB peripherals by STM32 device.

**Table 13. Certified USB peripherals**

STM32 device	Certified category	Speed(s)	TID
STM32F072	Peripheral	LS/FS	40001561
STM32F103	Peripheral	LS/FS	40000455
STM32F105	Peripheral	LS/FS	40001571
STM32F205/7	Peripheral	LS/FS	40001366
STM32F205/7	Peripheral	HS	40001365
STM32F207	Embedded host	FS	120000252
STM32F207	Embedded host	HS	120000251
STM32F303	Peripheral	LS/FS	40001494
STM32F373	Peripheral	LS/FS	40001496
STM32F405/7	Peripheral	HS	40001393
STM32F405/7	Peripheral	LS/FS	40001394
STM32F407	Embedded host	HS	120000253
STM32F407	Embedded host	FS	120000256
STM32F723	Peripheral	HS	40001777
STM32F723	Embedded host	FS	120000703
STM32F723	Embedded host	HS	120000702
STM32F723	Peripheral	LS/FS	40001776
STM32L053	Peripheral	LS/FS	40001612
STM32L152	Peripheral	LS/FS	10730015
STM32L476, STM32L476ZGT6U	Peripheral	LS/FS	40001658
STM32L476, STM32L476ZGT6U	Embedded host	FS	120000348

STM32 Device	Certified category	Speed(s)	TID
STM32F723IE	Embedded host	HS	120000702
STM32F723IE	Embedded host	FS	120000703
STM32F723IE	Embedded host	HS	40001777
STM32F769	Peripheral Silicon > Other	FS	8725
STM32F769	Embedded Host Silicon	HS	10646
STM32L496	Embedded host	FS	120000831
STM32L496AG	Peripheral	LS/FS	40001802
STM32L4P5	Embedded Host Silicon	FS	7861
STM32L4R9	Embedded Host	FS	7862
STM32L4R9	Peripheral Silicon > Other	FS	7840
STM32L562	Peripheral	FS	6562
STM32H7B3	Peripheral Silicon > Other	HS	8741
STM32H7B3	Embedded Host Silicon	HS	8724
STM32H7A3	Embedded Host Silicon	FS	8709
STM32H7S	Embedded Host Silicon	HS	10643
STM32H7S	Peripheral Silicon > Other	FS	10644
STM32H503	Peripheral Silicon > Other	HS	9721
STM32H563	Peripheral Silicon > Other	HS	9717
STM32U585	Peripheral	FS	7189
STM32U545	Peripheral Silicon > Other	HS	9722
STM32U599	Peripheral Silicon > Other	FS	10645
STM32G0C	Peripheral	FS	7046
STM32G491	Peripheral	FS	6563
STM32G474	Peripheral	FS	6561
STM32WB55	Peripheral	FS	2196
STM32MP13	Dual Role Device Silicon	HS	8088
STM32G0	Embedded Host Silicon		
STM32MP15	Peripheral	HS	1735
STM32MP15	Embedded host	HS	2111

## 4 FAQs (frequently asked questions)

**Q:** What is the minimum operating voltage for USB?

**A:** The USB, including its internal transceiver, is functional only for  $V_{DD}/V_{DDUSB} \geq 2.7$ -V. However, to be compliant with the USB specification, a minimum of 3.0 V is needed. Below 2.7-V, the functionality of the internal transceiver is not ensured over the whole temperature range.

**Q:** The datasheet says that the USB transceiver functionality is ensured down to 2.7 V, but the full-speed electrical characteristics are degraded in 2.7 to 3.0 V voltage range. What is the meaning of this sentence?

**A:** When the USB operating voltage is below 3.0 V, STMicroelectronics guarantees that the PLL generates correctly the 48 MHz, and that the analog transceivers are functional: the USB is correctly operating.

However, the electrical signals are not compliant with the USB2.0 full-speed specification, and, consequently, some tests needed to get the USB certification (such as the eye diagram test) do not pass. In other words, the USB is operational, but the customer cannot get the USB certification.

Refer to [www.usb.org](http://www.usb.org) for more details about the electrical requirements needed to be compliant with the USB specification.

**Q:** The pull-up resistor on a D+ line must always be added for the STM32 acting as a full speed device?

**A:** A full-speed device uses a pull-up resistor attached to D+ to specify itself as a full-speed device (and to indicate its speed). The pull-up resistor at the device end is also used by the host or hub to detect the presence of a device connected to its port. Without a pull-up resistor, the USB assumes that there is nothing connected to the bus.

On some STM32 microcontrollers, the pull-up resistor is already embedded. Otherwise, the customer needs to add it. Refer to *Embedded pull-up resistor on USB\_DP* line in [Section 2](#) to know if this resistor is integrated on the used STM32 MCU.

**Q:** In order to manage the VBUS sensing for USB device, are there any recommendations for the resistor bridge values?

**A:** Resistor bridge values must be chosen with respect to the following conditions:

- Voltage must be lower than 4 V.
- Voltage must be higher than  $0.7 \times V_{DD}$ .
- A 200  $\mu$ A typical current consumption is tolerated.

Refer to "*Management of VBUS sensing for USB device design*" shared on <http://community.st.com>.

**Q:** Can the external clock source (HSE bypass mode) be used for the USB clock source?

**A:** Yes, this is possible. HSE ON with an external crystal or HSE in bypass mode are required, but HSI cannot be used.

**Q:** Can we use two USB ports simultaneously (when they are available)?

**A:** Yes, this is feasible.

**Q:** Is it possible to connect more than one device to the same USB port configured as a host?

**A:** No, hub operation is not supported.

**Q:** Can the STM32 USB FS peripheral be used to make a USB LS device?

**A:** No, only full-speed transfers are supported in device mode. Refer to [Section 2.2](#) for more details.

**Q:** According to the USB specification (FS driver characteristics), when the full-speed driver is/is not part of a high-speed capable transceiver, the impedance of each of the drivers must be in the range 40.5 to 49.5  $\Omega$ /28 to 44  $\Omega$ , respectively. Are the STM32 devices embedding these matching resistors?

**A:** Yes. On the internal USB PHYs, the matching output impedance is already embedded in the pad transceiver and is in line with the USB specification. No external resistors are needed.

**Q:** Is it possible to use the USB peripheral when the operating voltage  $V_{DD}$  on the MCU is below 2.7 V?

**A:** This is possible only if a  $V_{DDUSB}$  pin is available to power the USB block. In this case, the microcontroller can be powered with the minimum specified supply voltage, while an independent 3.3 V power supply can be connected to  $V_{DDUSB}$ .

## 5 Conclusion

---

This application note helps STM32 MCUs users to correctly design their USB applications.

All aspects described inside this document, and specifically the requirements described in [Section 3](#), are mandatory for correct operation of the USB peripheral on STM32 MCUs, and for ensuring its electrical compliance with the USB standard.

## Revision history

**Table 14. Document revision history**

Date	Version	Changes
10-Aug-2016	1	Initial release.
24-Nov-2016	2	Document classification updated from public to ST Restricted.
27-Apr-2018	3	<ul style="list-style-type: none"> <li>Document classification changed from ST Restricted to Public.</li> <li>Scope extended to all STM32 microcontrollers.</li> <li>Updated Introduction and Section 3: Hardware guidelines for USB implementation and its subsections.</li> <li>Added Section 1: List of abbreviations and acronyms, Section 2: USB on STM32 products and its subsections, Section 4: FAQs and Section 6: Conclusion.</li> <li>Updated all figures in Section 3: Hardware guidelines for USB implementation.</li> <li>Removed former Table 1: Applicable products, Section 1: Layout guidelines for USB FS devices, Section 1.1: PCB track impedance and routing on FS data lines, Section 4: Hardware guideline for OTG product implementation and Section 5: OTG USB high speed PHY connected to STM32 through the ULPI link.</li> </ul>
18-Dec-2018	4	<p>Added Table 1. Applicable products</p> <p>Updated:</p> <ul style="list-style-type: none"> <li>Section 1 General information</li> <li>Table 3. USB implementation in STM32 devices</li> <li>Section 2.1 USB implementation on STM32 products and all its tables</li> <li>Section 2.4 Clock</li> <li>Section 3.1.1 USB FS upstream port in self-powered applications</li> <li>Section 3.1.2 USB FS upstream port in bus-powered applications</li> <li>Section 3.2 USB FS downstream port</li> <li>Section 4 FAQs (frequently asked questions)</li> <li>Section 6 Conclusion</li> <li>All figures in the document</li> </ul>
30-May-2022	5	<p>Updated:</p> <ul style="list-style-type: none"> <li><a href="#">Section 2.6: VBUS sensing detection</a></li> <li><a href="#">STM32F105/107 in Table 3. USB implementation on STM32 mainstream products</a></li> <li><a href="#">Figure 7. USB FS upstream port with embedded pull-up resistor in self-powered applications</a></li> <li><a href="#">Figure 12. OTG schematic implementation (dual-mode)</a></li> <li><a href="#">References integrated in Section 1: General information</a></li> </ul>
17-Apr-2023	6	<p>Updated:</p> <ul style="list-style-type: none"> <li><a href="#">Section 2: USB on STM32 products</a></li> <li><a href="#">Section 2.6: VBUS sensing detection</a></li> <li><a href="#">Figure 8. USB FS upstream port without embedded pull-up resistor in self-powered applications</a></li> <li><a href="#">Table 1. Applicable products</a></li> <li><a href="#">Section 2: USB on STM32 products</a></li> <li><a href="#">Table 4. USB implementation on STM32 high-performance products</a></li> <li><a href="#">Table 5. USB implementation on STM32 ultra-low-power products</a></li> </ul>
06-May-2024	7	Updated:

Date	Version	Changes
		<ul style="list-style-type: none"> <li>• Section 2.6: VBUS sensing detection</li> <li>• Section 3.3: OTG applications through embedded PHY</li> <li>• Section 3.1.1: USB FS upstream port in self-powered applications</li> <li>• Table 1. Applicable products</li> <li>• Section 2: USB on STM32 products</li> <li>• Table 3. USB implementation on STM32 mainstream products</li> <li>• Table 4. USB implementation on STM32 high-performance products</li> <li>• Table 5. USB implementation on STM32 ultra-low-power products</li> <li>• Table 13. Certified USB peripherals</li> <li>• Figure 13. USB HS via ULPI interface</li> <li>• Figure 12. OTG schematic implementation (dual-mode)</li> <li>• Figure 11. USB FS downstream implementation</li> <li>• Figure 9. USB FS upstream port with embedded pull-up resistor in bus-powered applications</li> <li>• Figure 10. USB FS upstream port without embedded pull-up resistor in bus-powered applications</li> <li>• Figure 7. USB FS upstream port with embedded pull-up resistor in self-powered applications</li> <li>• Figure 8. USB FS upstream port without embedded pull-up resistor in self-powered applications</li> </ul> <p>Added:</p> <ul style="list-style-type: none"> <li>• Section 2.6.2: MOSFET detector</li> <li>• Section 2.6.1: Simple resistor divider</li> </ul>
26-Sep-2024	8	<p>Updated:</p> <ul style="list-style-type: none"> <li>• Section 2: USB on STM32 products</li> <li>• Section 3.4: OTG_HS PHY connected through ULPI</li> <li>• Section 2: USB on STM32 products</li> <li>• Table 3. USB implementation on STM32 mainstream products</li> <li>• Table 13. Certified USB peripherals</li> </ul>
20-Nov-2024	9	<p>Updated:</p> <ul style="list-style-type: none"> <li>• Table 1. Applicable products</li> <li>• Section 2: USB on STM32 products</li> <li>• Table 4. USB implementation on STM32 high-performance products</li> <li>• Table 5. USB implementation on STM32 ultra-low-power products</li> <li>• Section 2.5: Power</li> </ul> <p>Added:</p> <ul style="list-style-type: none"> <li>• Table 6. USB implementation on STM32 wireless products</li> </ul>
29-Jan-2025	10	<p>Updated:</p> <ul style="list-style-type: none"> <li>• Table 1. Applicable products</li> <li>• Section 2: USB on STM32 products</li> <li>• Table 4. USB implementation on STM32 high-performance products</li> <li>• Table 5. USB implementation on STM32 ultra-low-power products</li> </ul>
09-Mar-2026	11	<p>Updated:</p> <ul style="list-style-type: none"> <li>• Table 1. Applicable products</li> <li>• Section 2: USB on STM32 products</li> <li>• Section 3.1.1: USB FS upstream port in self-powered applications</li> </ul>

## Contents

<b>1</b>	<b>General information</b>	<b>3</b>
<b>2</b>	<b>USB on STM32 products</b>	<b>4</b>
2.1	USB implementation on STM32 products	4
2.2	Supported USB speeds	8
2.3	Protection against ESD and EMI	8
2.4	Clock	10
2.5	Power	10
2.6	VBUS sensing detection	11
2.6.1	Simple resistor divider	11
2.6.2	MOSFET detector	12
<b>3</b>	<b>Hardware guidelines for USB implementation</b>	<b>13</b>
3.1	USB FS upstream port	13
3.1.1	USB FS upstream port in self-powered applications	13
3.1.2	USB FS upstream port in bus-powered applications	14
3.2	USB FS downstream port	15
3.3	OTG applications through embedded PHY	15
3.4	OTG_HS PHY connected through ULPI	16
3.4.1	External USB HS PHYs compatible via ULPI interface	18
3.5	USB applications through the embedded OTG_HS PHY	18
3.6	STM32 on USB-IF integrators list	19
<b>4</b>	<b>FAQs (frequently asked questions)</b>	<b>21</b>
<b>5</b>	<b>Conclusion</b>	<b>23</b>
	<b>Revision history</b>	<b>24</b>
	<b>List of tables</b>	<b>27</b>
	<b>List of figures</b>	<b>28</b>

## List of tables

<b>Table 1.</b>	Applicable products . . . . .	2
<b>Table 2.</b>	Abbreviations and acronyms . . . . .	3
<b>Table 3.</b>	USB implementation on STM32 mainstream products. . . . .	4
<b>Table 4.</b>	USB implementation on STM32 high-performance products . . . . .	5
<b>Table 5.</b>	USB implementation on STM32 ultra-low-power products . . . . .	6
<b>Table 6.</b>	USB implementation on STM32 wireless products . . . . .	7
<b>Table 7.</b>	Supported OTG_FS speeds . . . . .	8
<b>Table 8.</b>	Supported OTG_FS speeds . . . . .	8
<b>Table 9.</b>	JESD22-A114D standard class levels . . . . .	9
<b>Table 10.</b>	IEC 61000-4-2 standard class levels . . . . .	9
<b>Table 11.</b>	ESD protection . . . . .	10
<b>Table 12.</b>	Compatible USB HS PHY . . . . .	18
<b>Table 13.</b>	Certified USB peripherals . . . . .	19
<b>Table 14.</b>	Document revision history . . . . .	24

## List of figures

<b>Figure 1.</b>	JESD22-A114D standard test waveform . . . . .	8
<b>Figure 2.</b>	IEC 61000-4-2 standard waveform . . . . .	9
<b>Figure 3.</b>	HS PHY PLLs on STM32F7x3 devices . . . . .	10
<b>Figure 4.</b>	Simple resistor divider . . . . .	12
<b>Figure 5.</b>	Resistor divider supporting both 1.8 and 3.3V ranges . . . . .	12
<b>Figure 6.</b>	VBUS detection when GPIO max . . . . .	12
<b>Figure 7.</b>	USB FS upstream port with embedded pull-up resistor in self-powered applications . . . . .	13
<b>Figure 8.</b>	USB FS upstream port without embedded pull-up resistor in self-powered applications . . . . .	14
<b>Figure 9.</b>	USB FS upstream port with embedded pull-up resistor in bus-powered applications . . . . .	14
<b>Figure 10.</b>	USB FS upstream port without embedded pull-up resistor in bus-powered applications . . . . .	15
<b>Figure 11.</b>	USB FS downstream implementation . . . . .	15
<b>Figure 12.</b>	OTG schematic implementation (dual-mode) . . . . .	16
<b>Figure 13.</b>	USB HS via ULPI interface . . . . .	17

**IMPORTANT NOTICE – READ CAREFULLY**

STMicroelectronics NV and its subsidiaries (“ST”) reserve the right to make changes, corrections, enhancements, modifications, and improvements to ST products and/or to this document at any time without notice.

In the event of any conflict between the provisions of this document and the provisions of any contractual arrangement in force between the purchasers and ST, the provisions of such contractual arrangement shall prevail.

The purchasers should obtain the latest relevant information on ST products before placing orders. ST products are sold pursuant to ST’s terms and conditions of sale in place at the time of order acknowledgment.

The purchasers are solely responsible for the choice, selection, and use of ST products and ST assumes no liability for application assistance or the design of the purchasers’ products.

No license, express or implied, to any intellectual property right is granted by ST herein.

Resale of ST products with provisions different from the information set forth herein shall void any warranty granted by ST for such product.

If the purchasers identify an ST product that meets their functional and performance requirements but that is not designated for the purchasers’ market segment, the purchasers shall contact ST for more information.

ST and the ST logo are trademarks of ST. For additional information about ST trademarks, refer to [www.st.com/trademarks](http://www.st.com/trademarks). All other product or service names are the property of their respective owners.

Information in this document supersedes and replaces information previously supplied in any prior versions of this document.

© 2026 STMicroelectronics – All rights reserved