LIS2MDL: ultralow-power, high-performance 3-axis magnetometer

Introduction

This document provides usage information and application hints related to ST's LIS2MDL magnetic sensor.

The LIS2MDL is a 3-axis digital magnetometer system-in-package with a digital I²C and 3-wire / 4-wire SPI serial interface standard output, performing at 200 μ A in high-resolution mode and no more than 50 μ A in low-power mode (at 20 Hz output data rate). Thanks to the ultralow noise performance of the magnetometer, the device combines always-on, low-power features with superior sensing precision for an optimal motion experience for the consumer.

The device has a magnetic field dynamic range of ± 50 gauss.

The LIS2MDL can be configured to generate an interrupt signal for magnetic field detection and to automatically compensate for hard-iron offsets provided from the higher application layer.

ST software support available for the LIS2MDL includes drivers, a tilt-compensated electronic compass, dynamic magnetometer calibration, and 6-axis or 9-axis sensor fusion.

1 Pin description

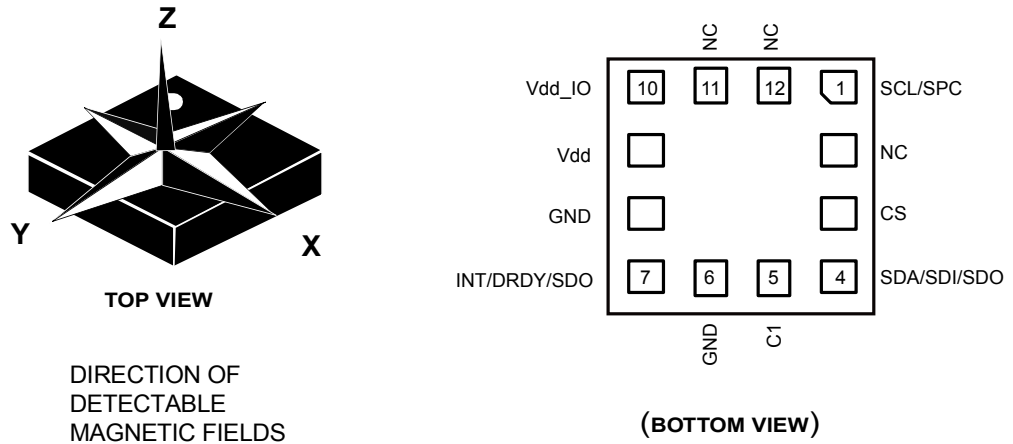
Figure 1. Pin connections

Table 1. Pin description

Pin#	Name	Function	Pin status
1	SCL SPC	I ² C serial clock (SCL) SPI serial port clock (SPC)	Default: input without pull-up
2	NC ⁽¹⁾		Internally not connected
3	CS	Enable SPI I ² C/SPI mode selection 1: SPI idle mode / I ² C communication enabled; 0: SPI communication mode / I ² C disabled	Default: input without pull-up
4	SDA SDI SDO	I ² C serial data (SDA) SPI serial data input (SDI) SPI 3-wire interface serial data output (SDO)	Default: (SDA) input without pull-up
5	C1	Capacitor connection (C1 = 220 nF)	External capacitor, voltage forced by the device
6	GND	0 V	
7	INT DRDY SDO	Interrupt signal (INT) Data-ready signal (DRDY) SPI 4-wire serial data output (SDO)	Default: input without pull-up
8	GND	0 V	
9	Vdd	Power supply	
10	Vdd_IO	Power supply for I/O pins	
11	NC ⁽¹⁾		Internally not connected
12	NC ⁽¹⁾		Internally not connected

1. This pin can be tied to Vdd, Vdd_IO, or GND.

1.1 INT/DRDY/SDO pin configuration

The INT/DRDY/SDO pin can be configured to have three different functions:

- Act as a hardware signal to determine when an interrupt event occurs (INT)
- Act as a hardware signal to determine when a new set of measurements is available to be read (DRDY)
- Act as SPI 4-wire serial interface output (SDO)

The INT signal in the INT_SOURCE_REG register can be driven to the INT/DRDY/SDO pin by setting the INT_on_PIN bit in CFG_REG_C to 1 (see [Section 10: Interrupt generation](#) for further details).

The Zyxda data-ready signal in the STATUS_REG register can be driven to the INT/DRDY/SDO pin by setting the DRDY_on_PIN bit in the CFG_REG_C register to 1 (see [Section 6.3: Using the data-ready signal](#) for further details).

The INT/DRDY/SDO pin can be configured to act as the SPI 4-wire serial interface output (SDO) by setting the 4WSPI bit in the CFG_REG_C register to 1.

Note:

The INT/DRDY/SDO pin can be configured to have only one functionality.

The available configurations for the INT_on_PIN, DRDY_on_PIN, and 4WSPI bits of the CFG_REG_C register are summarized in the table below.

Other configurations are forbidden.

Table 2. INT/DRDY/SDO pin configuration

INT_on_PIN	DRDY_on_PIN	4WSPI	INT/DRDY/SDO pin status	INT/DRDY/SDO pin function
0	0	0	Input without pull-up	None ⁽¹⁾
1	0	0	Push-pull output	INT signal routed
0	1	0	Push-pull output	DRDY (Zyxda) signal routed
0	0	1	Push-pull output	SDO (SPI 4-wire serial data output)

1. If this configuration is used, it is necessary to polarize the INT/DRDY/SDO pin to Vdd_IO or GND in order to avoid additional power consumption.

2 Registers

Table 3. Registers

Register name	Address	Bit7	Bit6	Bit5	Bit4	Bit3	Bit2	Bit1	Bit0
OFFSET_X_REG_L	45h	Offset_X_7	Offset_X_6	Offset_X_5	Offset_X_4	Offset_X_3	Offset_X_2	Offset_X_1	Offset_X_0
OFFSET_X_REG_H	46h	Offset_X_15	Offset_X_14	Offset_X_13	Offset_X_12	Offset_X_11	Offset_X_10	Offset_X_9	Offset_X_8
OFFSET_Y_REG_L	47h	Offset_Y_7	Offset_Y_6	Offset_Y_5	Offset_Y_4	Offset_Y_3	Offset_Y_2	Offset_Y_1	Offset_Y_0
OFFSET_Y_REG_H	48h	Offset_Y_15	Offset_Y_14	Offset_Y_13	Offset_Y_12	Offset_Y_11	Offset_Y_10	Offset_Y_9	Offset_Y_8
OFFSET_Z_REG_L	49h	Offset_Z_7	Offset_Z_6	Offset_Z_5	Offset_Z_4	Offset_Z_3	Offset_Z_2	Offset_Z_1	Offset_Z_0
OFFSET_Z_REG_H	4Ah	Offset_Z_15	Offset_Z_14	Offset_Z_13	Offset_Z_12	Offset_Z_11	Offset_Z_10	Offset_Z_9	Offset_Z_8
WHO_AM_I	4Fh	0	1	0	0	0	0	0	0
CFG_REG_A	60h	COMP_TEMP_EN	REBOOT	SOFT_RST	LP	ODR1	ODR0	MD1	MD0
CFG_REG_B	61h	0	0	0	OFF_CANC_ONE_SHOT	INT_on_DataOFF	Set_FREQ	OFF_CANC	LPF
CFG_REG_C	62h	0	INT_on_PIN	I2C_DIS	BDU	BLE	4WSPI	Self_test	DRDY_on_PIN
INT_CTRL_REG	63h	XIEN	YIEN	ZIEN	0	0	IEA	IEL	IEN
INT_SOURCE_REG	64h	P_TH_S_X	P_TH_S_Y	P_TH_S_Z	N_TH_S_X	N_TH_S_Y	N_TH_S_Z	MROI	INT
INT_THS_L_REG	65h	TH7	TH6	TH5	TH4	TH3	TH2	TH1	TH0
INT_THS_H_REG	66h	TH15	TH14	TH13	TH12	TH11	TH10	TH9	TH8
STATUS_REG	67h	Zyxor	zor	yor	xor	Zyxda	zda	yda	xda
OUTX_L_REG	68h	D7	D6	D5	D4	D3	D2	D1	D0
OUTX_H_REG	69h	D15	D14	D13	D12	D11	D10	D9	D8
OUTY_L_REG	6Ah	D7	D6	D5	D4	D3	D2	D1	D0
OUTY_H_REG	6Bh	D15	D14	D13	D12	D11	D10	D9	D8
OUTZ_L_REG	6Ch	D7	D6	D5	D4	D3	D2	D1	D0
OUTZ_H_REG	6Dh	D15	D14	D13	D12	D11	D10	D9	D8
TEMP_OUT_L_REG	6Eh	Temp7	Temp6	Temp5	Temp4	Temp3	Temp2	Temp1	Temp0
TEMP_OUT_H_REG	6Fh	Temp15	Temp14	Temp13	Temp12	Temp11	Temp10	Temp9	Temp8



3 Operating modes

The LIS2MDL provides three operating modes:

- Idle mode
- Continuous mode
- Single mode

After the power supply is applied, the LIS2MDL performs a 20 ms boot procedure to load the trimming parameters. After the boot is completed, the magnetometer is automatically configured in idle mode.

The device offers a wide V_{dd} and V_{dd}_IO voltage range from 1.71 V to 3.6 V.

In order to avoid potential conflicts, during the power-on sequence it is recommended to set the lines connected to the device IO pins to a high-impedance state on the host side. Furthermore, to guarantee proper power-off of the device it is recommended to maintain the duration of the V_{dd} line to GND for at least 100 μs.

The operating modes of the device can be set through the MD[1:0] bits of CFG_REG_A as shown in the table below.

Table 4. Operative modes

MD1	MD0	Mode
0	0	Continuous mode
0	1	Single mode
1	0	Idle mode
1	1	Idle mode

In all three operating modes, the typical value of the magnetic dynamic range is 50 gauss, which applies when the magnetic field is fully aligned to one of the sensitive axes. In the presence of a stray field in the cross-axis direction, the magnetic dynamic range can decrease down to 25 gauss (in the worst case).

3.1 Idle mode

When the magnetometer is in idle mode, almost all internal blocks of the device are switched off to minimize power consumption. Digital interfaces (I²C and SPI) are still active to allow communication with the device. The content of the configuration registers is preserved and the output data registers are not updated, keeping the last data sampled in memory before going into idle mode.

3.2 Continuous mode

Continuous mode can be enabled by writing the MD[1:0] bits to 00 in the CFG_REG_A register.

In continuous mode, the device continuously performs measurements and places the results in the output data registers. Either high-resolution or low-power mode can be selected by configuring the LP bit in CFG_REG_A (refer to [Section 4: Power modes](#)).

In continuous mode, the output data rate can be selected using the ODR[1:0] bits of the CFG_REG_A register as shown in the table below.

Table 5. Output data rate configuration

ODR1	ODR0	ODR (Hz)
0	0	10 (default)
0	1	20
1	0	50
1	1	100

3.3 Single mode

The LIS2MDL offers single mode in both high-resolution and low-power modes (refer to [Section 4: Power modes](#)).

Single mode configuration allows performing a single acquisition upon request; the acquisition is triggered by writing the MD[1:0] bits to 01 in the CFG_REG_A register. Once the measurement has been performed, the Zyxda, zda, yda, xda bits of the STATUS_REG register are asserted, data are available in the output registers and the LIS2MDL is automatically configured in idle mode by setting the MD[1:0] bits to 11.

Single mode is independent of the programmed ODR: it depends on the frequency at which the MD[1:0] bits are written by the microcontroller/application processor. The maximum ODR frequency achievable in single mode is given in the following table and strictly depends on the power mode selected (refer to [Section 4: Power modes](#)).

Table 6. Maximum ODR in single mode

Power mode (LP bit of CFG_REG_A register)	Maximum ODR [Hz]
High-resolution (LP = 0)	100
Low-power (LP = 1)	150

In single mode, the typical time needed for the generation of the new data corresponds to the turn-on time indicated in [Table 8. Operating mode and turn-on time](#).

4 Power modes

The LIS2MDL provides two power modes, operating with the device configured either in continuous or single mode:

- High-resolution mode
- Low-power mode

The device power mode can be selected by configuring the LP bit of the CFG_REG_A register. If the LP bit is asserted, the device operates in low-power mode, otherwise it operates in high-resolution mode (default configuration).

In both low-power mode and high-resolution mode, the magnetometer circuitry is periodically turned on/off with a duty cycle that is a function of the selected ODR and data interrupt generation is active.

The difference distinguishing the two modes is in the number of samples used to generate each output sample, which is four times less in low-power mode than the number used in high-resolution mode, thus ensuring a lower power consumption.

The table below summarizes the supply current of the two power modes with offset cancellation disabled/enabled (the sensor offset cancellation feature can be configured using the OFF_CANC bit of CFG_REG_B register - refer to [Section 8: Magnetometer offset cancellation](#)).

Table 7. Supply current in continuous mode

ODR [Hz]	Supply current	Supply current	Supply current	Supply current
	(LP = 0 and OFF_CANC = 0) [uA]	(LP = 1 and OFF_CANC = 0) [uA]	(LP = 0 and OFF_CANC = 1) [uA]	(LP = 1 and OFF_CANC = 1) [uA]
10	100	25	120	50
20	200	50	235	100
50	475	125	575	235
100	950	250	1130	460

The following table summarizes the turn-on time of the device in the two different power modes with the offset cancellation function enabled or disabled (see [Section 8: Magnetometer offset cancellation](#)).

Table 8. Operating mode and turn-on time

Operating mode	Turn-on time	
	CFG_REG_A[OFF_CANC = 0]	CFG_REG_A[OFF_CANC = 1]
0 (high-resolution)	9.4 ms	9.4 ms + 1/ODR
1 (low-power)	6.4 ms	6.4 ms + 1/ODR

5 Magnetometer low-pass filter

The LIS2MDL device embeds a digital low-pass filter in order to reduce noise. The filter can be enabled by setting the LPF bit in CFG_REG_B.

Figure 2. Magnetometer filtering chain

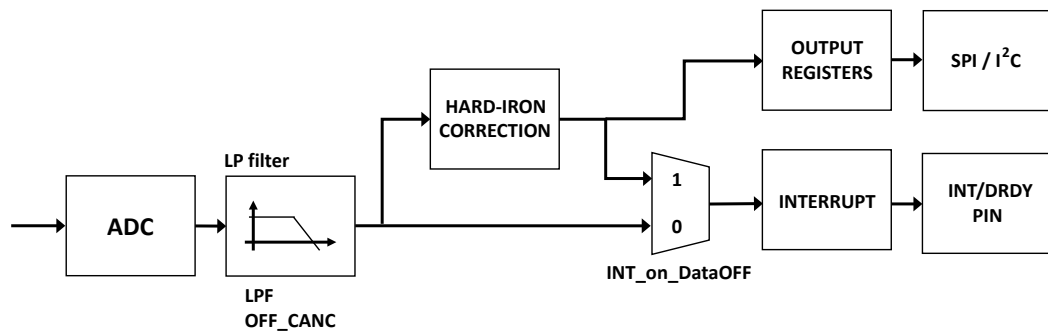

The table below summarizes the bandwidth and RMS noise values in different device configurations.

When the low-pass filter is enabled, the bandwidth is reduced while noise performance is improved without any increase in power consumption.

Note:

The offset cancellation feature (refer to [Section 8: Magnetometer offset cancellation](#)) works as a two-level moving average filter, thus giving the same bandwidth and noise performance as with the LPF filter enabled.

Table 9. RMS noise of operating modes

LPF or OFF_CANC	LP = 0		LP = 1	
	BW [Hz]	Noise RMS [mg]	BW [Hz]	Noise RMS [mg]
0 (disable)	ODR/2	4.5	ODR/2	9
1 (enable)	ODR/4	3	ODR/4	6

6 Reading output data

6.1 Startup sequence

Once the device is powered up, it automatically downloads the calibration coefficients from the embedded flash to the internal registers. When the boot procedure is completed (it takes 20 ms), the magnetometer automatically enters idle mode.

To turn on the magnetometer and gather magnetic data, it is necessary to select one of the operating modes through the CFG_REG_A register.

The following general-purpose sequence can be used to configure the magnetometer:

1. Write CFG_REG_A = 80h // Temperature compensation enabled
 // ODR = 10 Hz
 // Continuous and high-resolution modes
2. Write CFG_REG_C = 01h // Configure INT/DRDY/SDO pin as digital output by routing data-ready signal

Writing 81h in CFG_REG_A instead of 80h sets the device to operate in single mode instead of continuous mode.

6.2 Using the status register

The device is provided with a STATUS_REG register that should be polled to check when a new set of data is available (Zyxda = 1).

The reads should be performed as follows:

1. Read STATUS_REG.
2. If Zyxda = 0, then go to 1.
3. Read OUTX_L_REG.
4. Read OUTX_H_REG.
5. Read OUTY_L_REG.
6. Read OUTY_H_REG.
7. Read OUTZ_L_REG.
8. Read OUTZ_H_REG.
9. Data processing
10. Go to 1.

If the device is configured in single mode instead of continuous mode, the routine will be stuck at step 1 after one execution, since the device performs a single measurement, sets the Zyxda bit high, and returns to idle mode. Note that the MD bits automatically return to idle mode values. It is possible to trigger another single read by setting the MD bits to 01.

6.3 Using the data-ready signal

The device can be configured to have a hardware signal to determine when a new set of measurement data is available to be read.

The data-ready signal (DRDY) is represented by the Zyxda bit of the STATUS_REG register. This signal can be driven to the INT/DRDY/SDO pin by setting the DRDY_on_PIN bit of the CFG_REG_C register to 1.

The data-ready signal rises to 1 when a new set of data has been generated and it is available to be read. The signal is reset when the higher byte of one axis has been read (OUTX_H_REG, OUTY_H_REG, and OUTZ_H_REG registers).

6.4 Using the block data update (BDU) feature

If reading the magnetometer data is not synchronized with either the Zyxda event bit in the STATUS_REG register or with the data-ready signal driven to the INT/DRDY/SDO pin, it is strongly recommended to set the BDU (block data update) bit to 1 in the CFG_REG_C register.

This feature avoids reading values (most significant and least significant bytes of output data) related to different samples. In particular, when the BDU is activated, the data registers related to each axis always contain the most recent output data produced by the device, but, in case the read of a given pair (that is, OUTX_H_REG and OUTX_L_REG, OUTY_H_REG and OUTY_L_REG, OUTZ_H_REG and OUTZ_L_REG) is initiated, the refresh for that pair is blocked until both the MSB and LSB of the data are read.

Note: BDU only guarantees that the LSB and MSB have been sampled at the same moment. For example, if the reading speed is too slow, X and Y can be read at T1 and Z sampled at T2.

6.5 Understanding output data

The measured magnetic data are sent to the OUTX_H_REG, OUTX_L_REG, OUTY_H_REG, OUTY_L_REG, OUTZ_H_REG, and OUTZ_L_REG registers. These registers contain, respectively, the most significant byte and the least significant byte of the magnetic signals acting on the X, Y, and Z axes.

The complete output data for the X, Y, Z channels is given by the concatenation OUTX_H_REG & OUTX_L_REG, OUTY_H_REG & OUTY_L_REG, OUTZ_H_REG & OUTZ_L_REG and it is expressed as a two's complement number.

Magnetic data is represented as 16-bit numbers, called LSB. It must be multiplied by the proper sensitivity parameter, $M_So = 1.5 \text{ mG} / \text{LSB}$, in order to obtain the corresponding value in mG.

6.5.1 Example of output data

Hereafter is a simple example of how to use the LSB data and transform it into mG.

Get raw data from the sensor:

```
OUTX_L_REG: 21h
OUTX_H_REG: 00h
OUTY_L_REG: 1Dh
OUTY_H_REG: FFh
OUTZ_L_REG: CBh
OUTZ_H_REG: FEh
```

Do registers concatenation:

```
OUTX_H_REG & OUTX_L_REG: 0021h
OUTY_H_REG & OUTY_L_REG: FF1Dh
OUTZ_H_REG & OUTZ_L_REG: FECBh
```

Calculate signed decimal value (two's complement format):

```
X: +33
Y: -227
Z: -309
```

Apply sensitivity:

```
X: +33 * 1.5 = +49.5 mG
Y: -227 * 1.5 = -340.5 mG
Z: -309 * 1.5 = -463.5 mG
```

6.5.2 Big-little endian selection

The LIS2MDL allows swapping the content of the LIS2 and the upper byte of the output data registers (that is, OUTX_H_REG with OUTX_L_REG, and TEMP_OUT_H_REG with TEMP_OUT_L_REG) in order to be compliant with both little-endian and big-endian data representations.

“Little endian” means that the low-order byte of the number is stored in memory at the lowest address, and the high-order byte at the highest address. This mode corresponds to the BLE bit of the CFG_REG_C register set to 0 (default configuration).

On the contrary, “Big endian” means that the high-order byte of the number is stored in memory at the lowest address, and the low-order byte at the highest address. This mode corresponds to the BLE bit of the CFG_REG_C register set to 1.

7 Reboot and software reset

After the device is powered up, the LIS2MDL performs a 20 ms boot procedure to load the trimming parameters. After the boot is completed, the magnetometer is automatically configured in idle mode.

During the boot time, the registers are not accessible.

After power-up, the trimming parameters can be reloaded by setting the REBOOT bit of the CFG_REG_A register to 1.

No toggle of the device power lines is required; after the reboot is completed, the device enters idle mode (regardless of the selected operating mode) after performing one measurement.

If the reset to the default value of the control registers is required, it can be performed by setting the SOFT_RST bit of the CFG_REG_A register to 1. The software reset procedure can take 5 μ s; the status of the reset is signaled by the status of the SOFT_RST bit of the CFG_REG_A register: once the reset is completed, this bit is automatically set low.

In order to avoid conflicts, the reboot and the software reset must not be executed at the same time (do not set to 1 at the same time both the REBOOT bit and SOFT_RST bit of the CFG_REG_A register).

The flow must be performed serially as shown in the example below:

1. Set the SOFT_RST bit of the CFG_REG_A register to 1.
2. Wait 5 μ s (or wait until the SOFT_RST bit of the CFG_REG_A register returns to 0).
3. Set the REBOOT bit of the CFG_REG_A register to 1.
4. Wait 20 ms.

8 Magnetometer offset cancellation

The LIS2MDL is based on AMR technology: a set pulse is needed to set an initial operating condition.

Offset cancellation is the result of performing a set and reset pulse in the magnetic sensor to realign the magnetic dipoles, and it can be enabled to remove the intrinsic sensor offset.

The offset cancellation technique is defined as follows:

$$H_{out} = \frac{H_n + H_{n-1}}{2}$$

where H_n and H_{n-1} are two consecutive magnetic field measurements, one after a set pulse, the other after a reset pulse.

Note: When the offset cancellation is disabled, only the set pulses are performed, whereas the reset pulses are never issued. This is valid for both continuous mode and single mode.

Considering a magnetic offset (H_{off}), the two magnetic field measurements are:

- Set: $H_n = H + H_{off}$
- Reset: $H_{n-1} = H - H_{off}$

The offset is cancelled according to the offset cancellation technique:

$$H_{out} = \frac{H_n + H_{n-1}}{2} = \frac{2H + H_{off} - H_{off}}{2} = H$$

If the device is operating in continuous mode, the offset cancellation is enabled by setting the OFF_CANC bit to 1 in CFG_REG_B. In this case, the configuration of the Set_FREQ bit is ignored and the set/reset pulses are continuously performed; a set pulse is applied to one measurement, a reset pulse is applied to the next measurement. If the offset cancellation is disabled (OFF_CANC = 0) and continuous mode is selected, the set pulse frequency can be configured by setting the Set_FREQ bit in CFG_REG_B. If Set_FREQ is set to 0, the set pulse is released every 64 ODR, otherwise if Set_FREQ is set to 1, the set pulse is released only at power-on from idle mode (a set of the magnetic sensor is performed anyway, even if the offset cancellation is disabled).

If the device is operating in single mode, in order to enable the offset cancellation, both OFF_CANC and OFF_CANC_ONE_SHOT bits must be set to 1 in CFG_REG_B. Enabling these bits, the impulse polarity is inverted between a single read and the next one. While offset cancellation is automatically managed by the device in continuous mode, if this feature is enabled in single mode, the user has to remove the offset manually using the formula below:

$$H_{out} = \frac{H_n + H_{n-1}}{2}$$

Offset cancellation using single reads is effective only if the reads are close in time, thus ensuring the offset does not drift between two consecutive reads.

If the offset cancellation is disabled (OFF_CANC = 0 and OFF_CANC_ONE_SHOT = 0) and single mode is selected, the set pulse is performed at every single measurement (that is, the set pulse frequency cannot be configured through the Set_FREQ bit of the CFG_REG_B register as for continuous mode). Consequently, if single mode measurements are triggered at a constant pace, the magnetometer power consumption is greater than that of the corresponding ODR in continuous mode.

9 Magnetometer hard-iron compensation

Hard-iron distortion occurs when a magnetic object is placed near the magnetometer and appears as a permanent bias in the sensor outputs. The hard-iron correction consists of compensating magnetic data from hard-iron distortion.

The operation is defined as follows:

$$H_{out} = H_{read} - H_{HI}$$

where:

- H_{read} is the generic uncompensated magnetic field data, as read by the sensor.
- H_{HI} is the hard-iron distortion field.
- H_{out} is the compensated magnetic data.

The computation of the hard-iron distortion field should be performed by an external processor. After the computation of the hard iron-distortion field has been performed, the measured magnetic data can be compensated.

The device offers the possibility of storing hard-iron data inside six dedicated registers from address 45h to 4Ah. Each register contains eight bits so that the hard-iron data can be expressed as a 16-bit two's complement number. The `OFFSET_X_REG_H`, `OFFSET_Y_REG_H`, and `OFFSET_Z_REG_H` registers should contain the MSBs of the hard-iron distortion field estimated along the X, Y, and Z axes respectively. The `OFFSET_X_REG_L`, `OFFSET_Y_REG_L`, and `OFFSET_Z_REG_L` registers should contain the LSBs of the hard-iron distortion field estimated along the X, Y, and Z axes respectively. Hard-iron data have the same format and sensitivity of the magnetic output data. The hard-iron values stored in dedicated registers are automatically subtracted from the output data.

10 Interrupt generation

In the LIS2MDL, the magnetometer interrupt signal generation is based on the comparison between the magnetometer output data and the programmable threshold.

To enable the interrupt function, the IEN bit in INT_CTRL_REG must be set to 1. In the LIS2MDL the interrupt function can be selectively enabled on each axis. In order to do this, the XIEN, YIEN, and ZIEN bits in INT_CTRL_REG need be set properly.

The threshold value can be programmed by setting the INT_THS_L_REG and INT_THS_H_REG registers.

The threshold is expressed in absolute value as a 15-bit unsigned number. The threshold has the same sensitivity as the magnetic data.

When magnetic data exceeds the positive or the negative threshold, an interrupt signal is generated and the INT bit in the INT_SOURCE_REG register goes high. Information about which axis has triggered the wake-up event is also available in the INT_SOURCE_REG register; in particular, when magnetic data exceeds the positive threshold the P_TH_S_[X, Y, Z] bit is set to 1, while if data exceeds the negative threshold the N_TH_S_[X, Y, Z] bit is set to 1. If magnetic data lay between the positive and the negative thresholds, no interrupt signal is generated.

Figure 3. Interrupt function

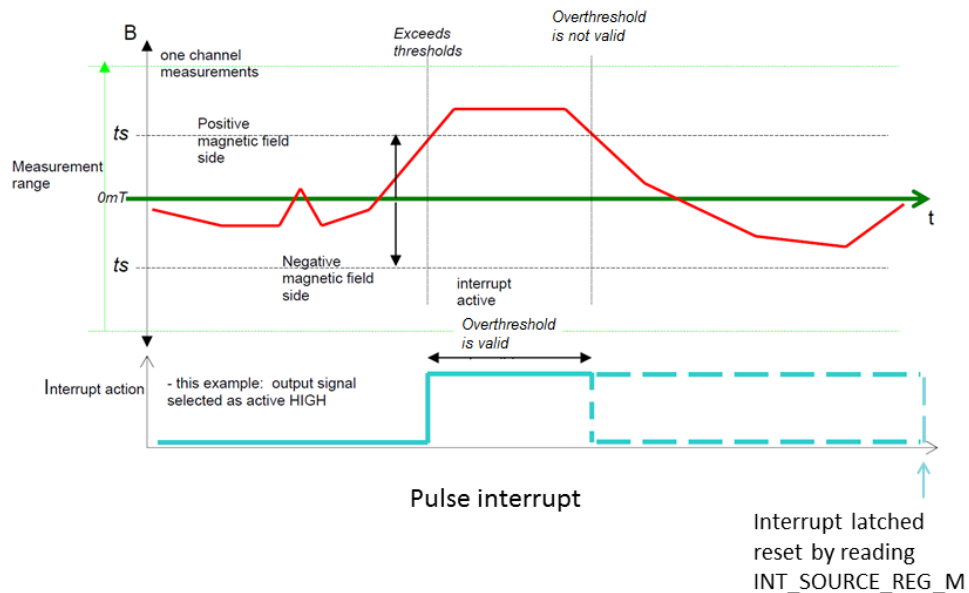

Two different approaches for the interrupt function are available:

- Typical: comparison is between magnetic data read by the sensor and the programmable threshold.
- Advanced: comparison is made between magnetic data after hard-iron correction and the programmable threshold.

These approaches are configurable by setting the INT_on_DataOFF bit in CFG_REG_B.

If INT_on_DataOFF is set to 0, the typical approach is selected, otherwise, if it is set to 1, the advanced approach is selected.

The hardware interrupt signal can be either pulsed or latched:

- Pulsed interrupt signal: it goes to active level when the magnetic data exceeds one of the two thresholds and goes low when the magnetic data are between the two thresholds (positive or negative). This kind of interrupt is selected by setting the IEL bit in the INT_CTRL_REG register to 0.
- Latched interrupt signal: it goes to active level when the data exceed one of the two thresholds but is reset only once the source register is read and not when the magnetic data returns between the two thresholds. This kind of interrupt is selected by setting the IEL bit in the INT_CTRL_REG register to 1.

The interrupt signal polarity can be set using the IEA bit in INT_CTRL_REG.

If IEA is set to 1, then the interrupt signal is active high, while if it is set to 0, the interrupt signal is active low.

10.1 Interrupt configuration example

A basic software routine for threshold event recognition is given below.

1. Write 80h in CFG_REG_A // Temperature compensation enabled
// ODR = 10 Hz
// Continuous mode and high-resolution
2. Write 40h in CFG_REG_C // Configure INT/DRDY/SDO pin as digital output by routing interrupt signal
3. Write 80h in INT_THS_L_REG // Set a threshold equal to 128 (expressed in LSB)
4. Write E7h in INT_CTRL_REG // Enable a latched active-high interrupt on the three axes

The sample code exploits a threshold set to 192 mG ($128 \text{ LSB} * 1.5 \text{ mG} / \text{LSB}$) and the event is notified by hardware through the INT/DRDY/SDO pin

10.2 Overflow interrupt

The MROI bit in INT_SOURCE_REG alerts the user if a measurement range overflow has occurred at the internal ADC level. This function is enabled only if the interrupt generator is active (IEN bit = 1). MROI behavior is always latched: once the internal measurement range overflow has occurred, the MROI bit is reset by reading INT_SOURCE_REG.

11 Temperature sensor

The LIS2MDL is provided with an internal temperature sensor.

The temperature sensor has to be enabled by setting the COMP_TEMP_EN bit in the CFG_REG_A register to 1.

Note: For proper operation of the magnetometer sensor, the COMP_TEMP_EN bit must be set to 1 by the user.

If the device is configured in continuous mode, the temperature sensor ODR is the same as the ODR of the magnetometer sensor, selected through the ODR[1:0] bits in the CFG_REG_A register. Otherwise, if the device is configured in single mode, the temperature sensor output data is generated upon user request together with the magnetometer sensor output data.

The temperature data is given by the concatenation of the TEMP_OUT_H_REG and TEMP_OUT_L_REG registers and it is represented as a number of 16 bits in two's complement format with a sensitivity of 8 LSB/°C. Typically, the output zero level corresponds to 25°C.

The LIS2MDL allows swapping, by setting the BLE bit of the CFG_REG_B register to 1, the content of the lower and the upper byte of the temperature output data registers.

12 Magnetometer self-test

The embedded self-test function allows checking device functionality without moving it. When the magnetometer self-test is enabled, a current is forced into a coil inside the device. This current generates a magnetic field that produces a variation of the magnetometer output signals. If the output signals change within the amplitude limits, then the sensor is working properly and the parameters of the magnetometer are within the defined specifications.

The magnetometer self-test function is off when the `Self_test` bit of the `CFG_REG_C` register is disabled; setting the `Self_test` bit to 1 enables the self-test.

When the magnetometer self-test is activated, the sensor output level is given by the algebraic sum of the signals produced by the magnetic field acting on the sensor and by the current forced.

The procedure consists of:

1. Enabling the magnetometer
2. Averaging fifty samples before enabling the self-test
3. Averaging fifty samples after enabling the self-test
4. Computing the difference in the module for each axis and verifying that it falls in the given range: the min and max values are provided in the datasheet

The complete magnetometer self-test procedure is indicated in [Figure 4](#).

Note: *Keep the device still during the self-test procedure.*

Figure 4. Magnetometer self-test procedure

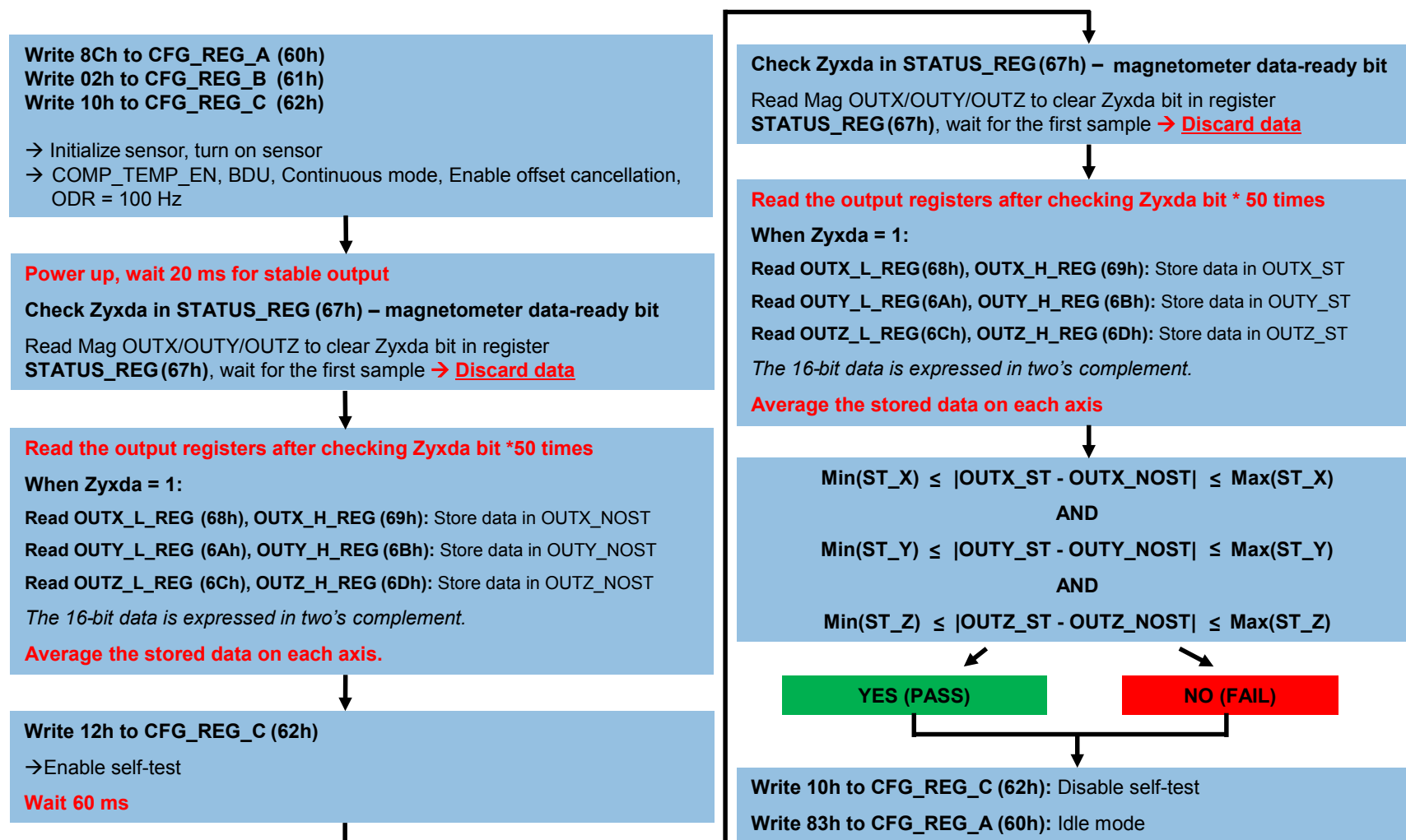

Revision history

Table 10. Document revision history

Date	Version	Changes
14-Sep-2017	1	Initial release
08-Jan-2018	2	Updated Section 8: Magnetometer offset cancellation
27-Oct-2020	3	Updated Section 1: Pin description and Section 1.1: INT/DRDY/SDO pin configuration Updated bit2 of register 62h in Table 3: Registers Updated Section 8: Magnetometer offset cancellation Minor textual updates
11-Nov-2024	4	Updated Section 8: Magnetometer offset cancellation Minor textual updates

Contents

1	Pin description	2
1.1	INT/DRDY/SDO pin configuration	3
2	Registers	4
3	Operating modes	5
3.1	Idle mode	5
3.2	Continuous mode	5
3.3	Single mode	6
4	Power modes	7
5	Magnetometer low-pass filter	8
6	Reading output data	9
6.1	Startup sequence	9
6.2	Using the status register	9
6.3	Using the data-ready signal	9
6.4	Using the block data update (BDU) feature	10
6.5	Understanding output data	10
6.5.1	Example of output data	10
6.5.2	Big-little endian selection	10
7	Reboot and software reset	11
8	Magnetometer offset cancellation	12
9	Magnetometer hard-iron compensation	13
10	Interrupt generation	14
10.1	Interrupt configuration example	15
10.2	Overflow interrupt	15
11	Temperature sensor	16
12	Magnetometer self-test	17
	Revision history	19
	List of tables	21
	List of figures	22

List of tables

Table 1.	Pin description	2
Table 2.	INT/DRDY/SDO pin configuration	3
Table 3.	Registers	4
Table 4.	Operative modes	5
Table 5.	Output data rate configuration	5
Table 6.	Maximum ODR in single mode	6
Table 7.	Supply current in continuous mode	7
Table 8.	Operating mode and turn-on time	7
Table 9.	RMS noise of operating modes	8
Table 10.	Document revision history	19

List of figures

Figure 1.	Pin connections	2
Figure 2.	Magnetometer filtering chain	8
Figure 3.	Interrupt function.	14
Figure 4.	Magnetometer self-test procedure.	18

IMPORTANT NOTICE – READ CAREFULLY

STMicroelectronics NV and its subsidiaries (“ST”) reserve the right to make changes, corrections, enhancements, modifications, and improvements to ST products and/or to this document at any time without notice. Purchasers should obtain the latest relevant information on ST products before placing orders. ST products are sold pursuant to ST’s terms and conditions of sale in place at the time of order acknowledgment.

Purchasers are solely responsible for the choice, selection, and use of ST products and ST assumes no liability for application assistance or the design of purchasers’ products.

No license, express or implied, to any intellectual property right is granted by ST herein.

Resale of ST products with provisions different from the information set forth herein shall void any warranty granted by ST for such product.

ST and the ST logo are trademarks of ST. For additional information about ST trademarks, refer to www.st.com/trademarks. All other product or service names are the property of their respective owners.

Information in this document supersedes and replaces information previously supplied in any prior versions of this document.

© 2024 STMicroelectronics – All rights reserved