

## How to use STPMIC25 to develop a wall adapter powered application on STM32MP25 MPUs

### Introduction

This application note applies to the STM32MP25x MPU devices as detailed in the table below. The devices are referred to as STM32MP25x in the rest of the document. It is powered by the STPMIC25 power management IC companion chip, which is fully featured to supply complete applications.

This document provides an example of a hardware reference design based on a STM32MP25x device. The STM32MP25x is powered by an external 5 V power supply via the STPMIC25 power management IC. The STPMIC25APQR and STPMIC25DPQR are suited for running I/O peripherals at 3.3 V.

This document is intended for product architects and designers who require information about the power management, and STPMIC25APQR and STPMIC25DPQR settings. This document focuses on:

- Reference design block diagram
- Power distribution topology
- Power on/off and low power management
- User reset and crash recovery management
- Safety management and PMIC tuning.

**Table 1. Applicable products**

Reference	Applicable products
STM32MP25x	STM32MP251, STM32MP253, STM32MP255, STM32MP257
STPMIC25	STPMIC25APQR, STPMIC25DPQR

## 1 General information

This document applies to STM32MP25x Arm® Cortex®-based MPUs and STPMIC25 power management IC.



Note:

*Arm and Cortex are registered trademarks of Arm Limited (or its subsidiaries or affiliates) in the US and/or elsewhere.*

*The Arm word and logo are trademarks of Arm Limited (or its subsidiaries) in the US and/or elsewhere. All rights reserved.*

## 2 Overview

This application note describes the interaction between the STM32MP25x, and the STPMIC25APQR and STPMIC25DPQR including the management of the following peripherals:

- DC input power source from main power supply: 5 V typical (4.1 V to 5.5 V).
- DDR4 memory.
- Peripheral I/O interface voltage ( $V_{DDIO}$ ) at 3.3 V powered by the STPMIC25.
- USB 3.0 superspeed port supporting power delivery to supply a USB device.
- eMMC flash memory (HS200) as boot device.
- SD-Card (UHS-I) which is not used as a boot device in this reference design.

*Note:* If boot over SD-Card (UHS-I) is required, the STPMIC25APQR can be replaced by the dedicated STPMIC25DPQR reference (see Section 4.1.8: SD-Card power domains ( $V_{DD\_SDCARD}$ ,  $V_{DDIO\_SDCARD}$ ))

Not covered in this application note:

- DDR3L and lpDDR4
- Peripheral interface with I/O voltage ( $V_{DDIO}$ ) of 1.8 V

In this document, MPU terminology refers to the STM32MP25x. The PMIC terminology refers to the STPMIC25 generic devices. The STPMIC25A and STPMIC25D references are used to highlight specific behaviors predefined in STPMIC25APQR NVM and STPMIC25DPQR NVM.

### 2.1 Reference documents

**Table 2. Reference documents**

-	Reference	Title
		STMicroelectronics document <sup>(1)</sup>
[1]	AN5489	Getting started with STM32MP25x MPUs hardware development
[2]	DS14278	Highly integrated power management IC for microprocessor units
[3]	RM0457	STM32MP25x advanced Arm®-based 32/64-bit MPUs
[4]	AN5726	How to implement low-power modes on the STM32MP2 MPUs
[5]	DS14284	Arm® based dual Cortex®-A35 1.5 GHz + Cortex®-M33 MPU with AI, 3D GPU, video encoder/decoder, TFT/DSI/LVDS, USB 3.0, PCIe®, crypto

1. Refer to [www.st.com](http://www.st.com)

### 3 Glossary

Table 3. Glossary

Term	Meaning
BUCK	Step down regulator
GPU	Graphics processing unit
LDO	Low drop out linear regulator
MPU	Microprocessor unit
NVM	Nonvolatile memory
PMIC	Power management integrated circuit
SMPS	Switching mode power supply
SW	Software

## 4 5 V power supply application reference design

---

This reference design targets an application powered by a 5 V power supply with 2 x DDR4, an eMMC, and an SD-Card that supports UHS-I mode.

The boot flash memory is on the eMMC. Other peripherals such as audio and display functions, are added to illustrate the application. A reference design with a USB 2.0/3.0 HS/FS with Type C supporting USB PD (power deliver) is available in [1].

The main peripheral interfaces function with an I/O voltage of 3V3. The overall system is illustrated in Figure 1.

*Note:* *STPMIC25Dis a dedicated reference for applications requiring the boot flash memory on SD-Card (UHS-I). See Section 4.1.8: SD-Card power domains ( $V_{DD\_SDCARD}$ ,  $V_{DDIO\_SDCARD}$ )*

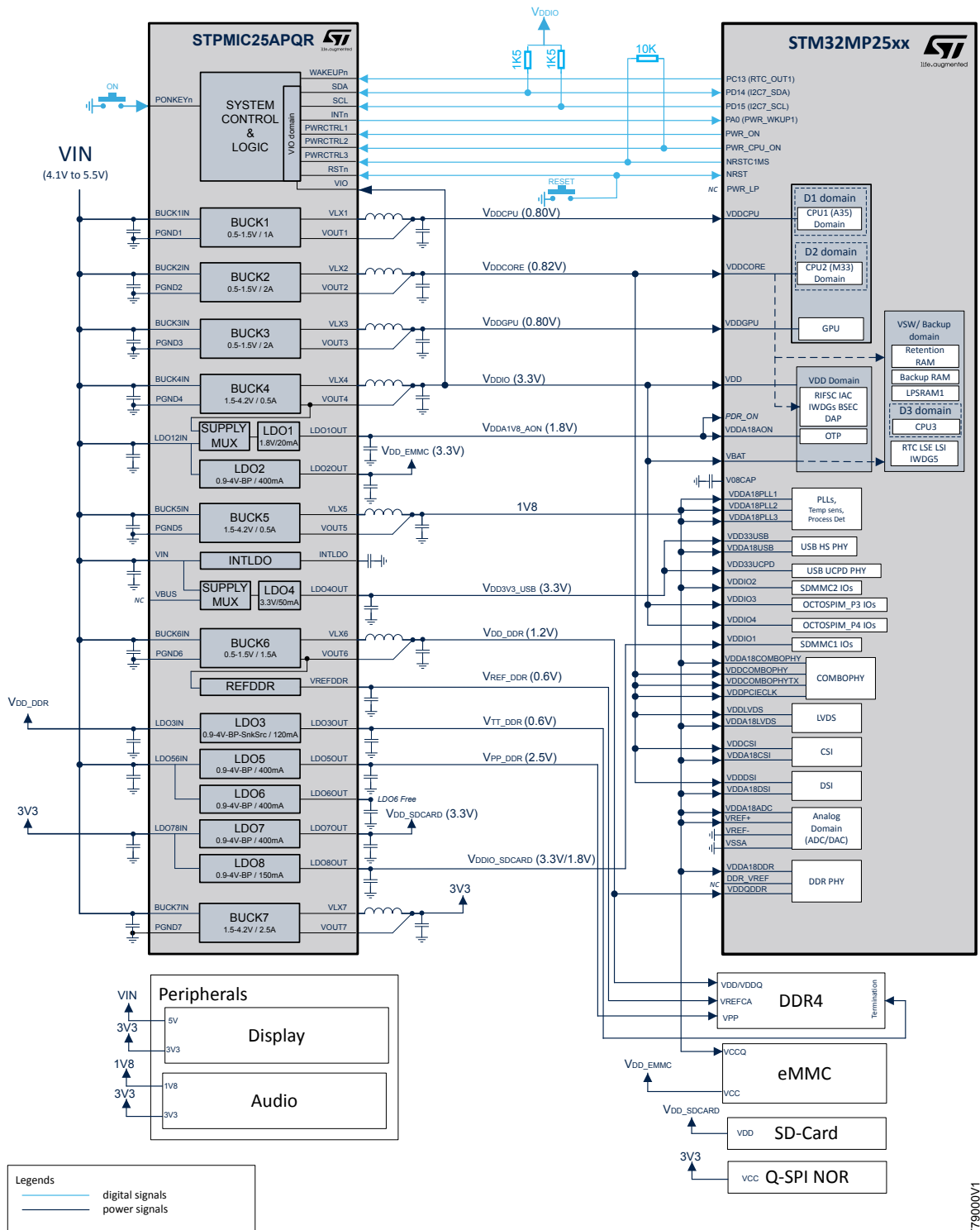
**Figure 1. STM32MP25x and STPMIC25A with 2xDDR4, eMMC, SD-card**

Note: The following are not shown in the diagram:

- STM32MP25x decoupling scheme (see [1])
- STPMIC25A discrete components value (see [2])
- $V_{IN}$  source and related protection, such as ESD, EMI filtering, overvoltage.

## 4.1 Power distribution

The PMIC integrates the regulators that supply:

- The STM32MP25x power domains
- The application peripherals.

### 4.1.1 V<sub>DDCPU</sub> power domain (800 mV/910 mV)

V<sub>DDCPU</sub> supplies the dual Arm® Cortex®-A35 platform (CPU1), called the D1 domain.

V<sub>DDCPU</sub> is powered from the PMIC BUCK1 step-down SMPS. The SMPS has an excellent load transient response across all operating conditions.

At power-up, the V<sub>DDCPU</sub> is automatically enabled by the PMIC at 800 mV, which corresponds to the “nominal mode” voltage. (See [Section 5.2.1: Power-up triggered by main supply \(V<sub>IN</sub>\) plugin/power-down by software shutdown](#)).

V<sub>DDCPU</sub> is enabled in:

- Run1 mode
- Low power LP-Stop1 mode
- Low power LPLV-Stop1 mode.

V<sub>DDCPU</sub> is disabled in:

- Run2 mode
- Low power LP-Stop2 mode
- Low power LPLV-Stop2 mode
- Low power Standby mode
- V<sub>BAT</sub> mode and OFF mode.

In low-power modes, the PWR\_CPU\_ON output of the MPU manages the PMIC V<sub>DDCPU</sub> regulator. The PWR\_CPU\_ON is connected to the PWRCTRL2 input of the PMIC.

At runtime, the CPU1 can operate in *nominal mode* or in *overdrive mode*. The V<sub>DDCPU</sub> voltage is then adjusted to the chosen mode. The MPU manages the transition between *nominal mode* voltage and *overdrive mode* voltage by sending I<sup>2</sup>C commands to the PMIC. The V<sub>DDCPU</sub> voltage is increased to the “overdrive mode” voltage value (910 mV) when the CPU1 frequency (Fcpu1\_overdrive) operates above 1200 MHz. When the CPU1 operates in “nominal mode” at 1200 MHz or below, the V<sub>DDCPU</sub> must be set back to “nominal mode” voltage value (800 mV).

### 4.1.2 V<sub>DDCORE</sub> power domain (670 mV / 820 mV)

V<sub>DDCORE</sub> is the main STM32MP25x digital power domain, and is called the D2 domain.

V<sub>DDCORE</sub> supplies all the digital circuits, which include:

- The Arm® Cortex®-M33 platform (CPU2)
- Some analog IP of the MPU such as:
  - COMBOPHY
  - LVDS
  - CSI
  - DSI, and so on.

V<sub>DDCORE</sub> is powered from the PMIC BUCK2 step-down SMPS. This SMPS has an excellent load transient response across operating conditions.

At power-up, V<sub>DDCORE</sub> is automatically enabled by the PMIC at 820 mV. (See [Section 5.2.1: Power-up triggered by main supply \(V<sub>IN</sub>\) plugin/power-down by software shutdown](#))

V<sub>DDCORE</sub> is enabled in:

- Run1 mode
- Run2 mode
- Low power LP-Stop1 mode
- Low power LP-Stop2 mode.

The voltage is lowered to 670 mV in:

- Low power LPLV-Stop1 mode
- Low power LPLV-Stop2 mode.

V<sub>DDCORE</sub> is disabled in:

- Low power Standby mode
- V<sub>BAT</sub> mode
- OFF mode.

In low power mode, the PWR\_ON output of the MPU manages the PMIC V<sub>DDCORE</sub> regulator. The PWR\_ON output is connected to the PWRCTRL1 input of the PMIC. V<sub>DDCORE</sub> also supplies the D3 backup domain and the retention domain in Run1 and Run2, and Stop1 and Stop 2 modes. (See [Section 4.1.10: MPU backup domain and retention domain](#)).

*Note:* D3 domain integrates all peripherals that must be functional in low power mode.

### 4.1.3 V<sub>DDGPU</sub> power domain (800 mV / 900 mV)

V<sub>DDGPU</sub> supplies the graphic processing unit (GPU) and neural processing unit (NPU).

V<sub>DDGPU</sub> is powered from the PMIC BUCK3 step-down SMPS. This SMPS has an excellent load transient response across operating conditions.

At power-up, V<sub>DDGPU</sub> is not automatically enabled by the PMIC.

At runtime, the MPU manages the V<sub>DDGPU</sub> regulator by sending I<sup>2</sup>C commands to the PMIC. By default, the V<sub>DDGPU</sub> regulator is set at 800 mV in “nominal mode” when the GPU frequency operates at 800 MHz or below. V<sub>DDGPU</sub> regulator is set at 900 mV to run in “overdrive mode” when the GPU frequency (f<sub>gpu\_overdrive</sub>) operates above 800 MHz. The V<sub>DDGPU</sub> regulator is disabled during low power modes.

### 4.1.4 V<sub>DDIO</sub> and V<sub>DDA1V8\_AON</sub> power domains

V<sub>DDIO</sub> is the power supply for the following independent MPU I/Os:

- V<sub>DD</sub>
- V<sub>DDIO1</sub>
- V<sub>DDIO2</sub>
- V<sub>DDIO3</sub>
- V<sub>DDIO4</sub>

V<sub>DDIO</sub> is also the power supply of the MPU V<sub>DD</sub> for the retention domain (see [Section 4.1.10: MPU backup domain and retention domain](#) for more details). These separate/dedicated I/O supplies can be set to different voltages or be shut down independently.

V<sub>DDA1V8\_AON</sub> domain supplies the MPU V<sub>DDA1V8\_AON</sub> system analog such as:

- Reset block
- Power management (POR/PDR)
- Oscillators (HSE, HSI)
- OTP controller (BSEC)

V<sub>DDIO</sub> is powered from the PMIC BUCK4 step-down SMPS, which is dedicated to the supply of sensitive powers domains and has a low output voltage ripple across all operating conditions. V<sub>DDA1V8\_AON</sub> is powered by the dedicated PMIC LDO1 linear regulator, which has a very low quiescent current to reduce power consumption during low power mode.

At power-up, V<sub>DDIO</sub> and V<sub>DDA1V8\_AON</sub> are automatically enabled to 3.3 V and 1.8 V respectively by the PMIC. They are the first regulators switched on at power-up (see [Section 5.2.1: Power-up triggered by main supply \(V<sub>IN</sub>\) plugin/power-down by software shutdown](#)).

The PMIC **LDO1** ( $V_{DDA1V8\_AON}$ ) has a built-in power supply multiplexor, which is either powered by **LDO12IN** (connected to  $V_{IN}$  supply at application level) or by the PMIC **BUCK4** output (**VOOUT4**). By default, when the PMIC is powered-up, the **LDO12IN** is selected as the **LDO1** power source. Once the MPU is powered on and initialized, the software switches the **LDO1** input source from **LDO12IN** to **BUCK4** output (**VOOUT4**) via an I<sup>2</sup>C command to the PMIC. This improves the power efficiency of the **LDO1** from 36%, when the **LDO1** input source is at 5 V from the **LDO12IN**, to 54%, when the **LDO1** input source is at 3.3 V from the **BUCK4** **VOOUT4**.

**Note:** *To set **LDO1** input source from **LDO12IN** to **VOOUT4**, the MPU software reprograms the PMIC **LDO1\_MAIN\_CR[INPUT\_SRC]** and **LDO1\_ALT\_CR[INPUT\_SRC]** registers bit to 1 via an I<sup>2</sup>C commands (see document [2] for details).*

In **Standby mode**, the **BUCK4** step-down SMPS is set to low power mode. The MPU sets the PMIC to **Standby mode** via the **PWR\_ON** output connected to the **PWRCTRL1** input of the PMIC (see document [2] for details). **VDDIO** and **VDDA1V8\_AON** are ON in all modes except in **OFF** or **VBAT** mode; when the main power source ( $V_{IN}$ ) of the application is removed (see Section 4.1.10: MPU backup domain and retention domain for details).

#### 4.1.5 **V<sub>DD3V3\_USB</sub> power domain**

**V<sub>DD3V3\_USB</sub>** power domain supplies the USB2 HS PHY (**V<sub>DD3V3\_USB</sub>**) and the USB PD (power delivery) PHY (**V<sub>DD33UCPD</sub>**) of the MPU.

**Note:** *Examples of USB implementations with the STM32MP25x are provided in the document [1].*

**V<sub>DD3V3\_USB</sub>** is powered from the dedicated PMIC **LDO4** with a fixed output voltage of 3.3 V.

**Note:** *The PMIC **LDO4** has a built-in power supply multiplexor powered either from **STPMIC25**  $V_{IN}$  pin or  $V_{BUS}$  pin, which automatically selects the highest input voltage. It is designed specifically for battery-powered applications to keep both the MPU USB PHY and PD PHY working when the battery is discharged. This feature is not applicable to this application note and the PMIC  $V_{BUS}$  pin must be left floating (unconnected).*

At power-up, the **V<sub>DD3V3\_USB</sub>** regulator is automatically enabled to 3.3 V by the PMIC (See Section 5.2.1: Power-up triggered by main supply ( $V_{IN}$ ) plugin/power-down by software shutdown).

If a USB peripheral is connected to the application, **V<sub>DD3V3\_USB</sub>** can be kept enabled in the following modes:

- **Run1 mode**
- **Run2 mode**
- **Low power LP-Stop1 mode**
- **Low power LP-Stop2 mode**
- **Low power LPLV-Stop1 mode**
- **Low power LPLV-Stop2 mode.**

**V<sub>DD3V3\_USB</sub>** is disabled in **Standby** and **OFF** mode. In this mode, the USB protection device (TCPP0x) must be shut down, so the USB CC lines are disconnected. In low power mode, MPU software controls the **V<sub>DD3V3\_USB</sub>** using I<sup>2</sup>C controls and it can be either switched ON/OFF.

#### 4.1.6 **DDR power domain (V<sub>DD\_DDR</sub>, V<sub>TT\_DDR</sub>, V<sub>PP\_DDR</sub>, V<sub>REF\_DDR</sub>)**

Several power domains are dedicated to supplying the DDR types supported by the MPU: **DDR3L**, **DDR4**, and **lpDDR4**.

This application focuses on **DDR4** topology.

**V<sub>DD\_DDR</sub>** (1.2 V) is powered from the PMIC **BUCK6** step-down SMPS to power the **DDR4** memory ICs (**V<sub>DDR</sub>** and **V<sub>DDQ</sub>**) and MPU **DDR PHY** (**V<sub>DDQDDR</sub>**) domains.

**V<sub>REF\_DDR</sub>** (0.6 V) is powered from the **STPMIC25** **REFDDR** sink source LDO. The supply source of the **REFDDR** LDO is internally connected to the **BUCK6** output (**VOOUT6**) and provides a voltage equal to  $V_{OUT6}/2$  to power the **DDR4** memory **V<sub>REFCA</sub>**.

**Note:**

- *The MPU **DDR\_VREF** must remain unconnected.*
- *If **BUCK6** is disabled but **REFDDR** is enabled, **V<sub>REF\_DDR</sub>** follows the output voltage of **BUCK6** with an output voltage equal to  $V_{OUT6}/2$ .*

**V<sub>TT\_DDR</sub>** (0.6 V) is powered from the PMIC multipurpose **LDO3**. When set in sink-source mode, the **LDO3** provides voltage equal to **V<sub>REF\_DDR</sub>** (implicitly  $V_{OUT6} / 2$ ). The **LDO3** sink-source mode is dedicated to power the **DDR4** memory bus terminations.

**Note:** When used in sink-source mode, the **BUCK6** output (**VDD\_DDR**) must supply the **LDO3** (**LDO3IN**). **VPP\_DDR** (2.5 V) is powered from the PMIC general purpose **LDO5** to power the DDR4 memory **VPP**. At power-up, the PMIC does not automatically start the following regulators:

- **VDD\_DDR**
- **VTT\_DDR**
- **VPP\_DDR**
- **VREF\_DDR**

The regulators are powered up sequentially by the software bootloader by sending I<sup>2</sup>C commands to the PMIC. This is detailed in the following section and in [Section 5.2.1: Power-up triggered by main supply \(V<sub>IN</sub>\) plugin/ power-down by software shutdown](#).

At runtime, the **PWR\_ON** output of the MPU, connected to the **PWRCTRL1** input of the PMIC, manages the DDR4 power domains as follows:

- **VTT\_DDR** (**LDO3**) is switched OFF, and the DDR4 is set in self-refresh in the following modes:
  - Low power LP-Stop1 mode
  - Low power LP-Stop2 mode
  - Low power LPLV-Stop1 mode
  - Low power LPLV-Stop2 mode.
- In **Standby mode**, there are two possible scenarios:
  - DDR4 in self-refresh: similarly to low power modes, is detailed in [Section 5.3.4: Standby mode \(DDR4 in self-refresh\)](#).
  - DDR4 OFF: all DDR regulators are powered OFF and detailed in [Section 5.3.5: Standby mode \(DDR4 OFF\)](#).

At power down, and before the software turns OFF the PMIC, a power-down sequence must be applied on DDR4 power domains to comply with the JEDEC DDR4 specification (see details in [Section 4.1.7: VDD\\_eMMC power domain \(3.3 V\)](#)).

**Note:** The PMIC embeds configurable pull-down discharge resistors on each of the regulator outputs that allow all of regulator output voltages to discharge in less than 1.5 ms. For BUCK regulators, two pull-down values are configurable in NVM with one of the following discharge delays:

- Slow pull-down set to 1.5 ms
- Fast pull-down set to 0.3 ms.

The “fast pull-down” configuration is used to switch off a power supply quickly than another one. The configuration is used on the DDR uncontrolled power down sequence.

#### Software DDR4 power-up sequence:

1. Power-on event (or standby DDR-OFF mode exit): PMIC power up (or standby DDR-OFF mode recovery)
2. The software bootloader executes DDR4 initialization.
3. The software bootloader sets the PMIC internal pull-down for each DDR regulator as described in the note below:
  - a. **LDO5** (**VPP\_DDR**) pull down is disabled when **LDO5** is disabled:  
LDOS\_PD\_CR1[LDO5\_PD] = 0
  - b. **BUCK6** (**VDD\_DDR**) fast pull down is activated when **BUCK6** is disabled:  
BUCKS\_PD\_CR2[BUCK6\_PD]=10
  - c. **REFDDR** (**VREF\_DDR**) pull down is activated when **REFDDR** is disabled:  
LDOS\_PD\_CR2[REFDDR\_PD] = 1
  - d. **LDO3** (**VTT\_DDR**) pull down is activated when **LDO3** is disabled:  
LDOS\_PD\_CR1[LDO3\_PD] = 1

**Note:** It is necessary to set this pull-down every time the MPU is powered up to prevent a “DDR4 uncontrolled power OFF sequence” (see [DDR4 uncontrolled power off sequence](#).)

4. The software bootloader enables the DDR regulators:
  - a. Enable **LDO5** ( $V_{PP\_DDR}$ ) at 2.5 V
  - b. Wait 1 ms tempo
  - c. Enable **LDO3** in sink-source mode ( $V_{TT\_DDR}$ )
  - d. Enable **REFDDR** ( $V_{REF\_DDR}$ )
  - e. Enable **BUCK6** ( $V_{DD\_DDR}$ ) at 1.2 V:  $V_{REF\_DDR}$  voltage and  $V_{TT\_DDR}$  voltage follow  $V_{DD\_DDR}$  ramp up.
  - f. Wait 1 ms tempo
5. Software initializes the MPU DDR4 memory controller and DDR4 devices.

*Note:* The above sequence aims to fulfill the JEDEC DDR4 where  $V_{PP\_DDR}$  must ramp at the same time or before  $V_{DD\_DDR}$ , and  $V_{PP\_DDR}$  must always be equal to or higher than  $V_{DD\_DDR}$ . Refer to the latest JEDEC DDR4 specification for more details.

#### Software DDR4 power down sequence:

1. Software receives an event to enter OFF mode or standby DDR-OFF mode.
2. Assert DDR CKE low
3. Disable **BUCK6** ( $V_{DD\_DDR}$ ):  $V_{REF\_DDR}$  voltage and  $V_{TT\_DDR}$  voltage follow  $V_{DD\_DDR}$  ramp down.
4. Wait 1 ms tempo
5. Disable  $V_{REF\_DDR}$
6. Disable **LDO3** ( $V_{TT\_DDR}$ )
7. Disable **LDO5** ( $V_{PP\_DDR}$ )

*Note:*  $V_{PP\_DDR}$  voltage falls slowly as **LDO5** pull-down discharge is disabled.

#### DDR4 uncontrolled power off sequence:

An uncontrolled power off sequence occurs typically when the main power supply voltage is removed or when a reset occurs.

In this case, the PMIC manages the power off sequence:

*Note:* To ensure this uncontrolled power down sequence, the PMIC pull-down settings are set at software boot (see [Software DDR4 power-up sequence](#)).

1.  $V_{IN}$  is removed.
2.  $V_{IN}$  falls below the **VINOK\_fall** threshold: PMIC triggers a *turn off* condition.
3. The PMIC starts the power off sequence.
  - a. The PMIC asserts the NRST signal: STM32MP25x stops the DDRPHYC especially the DRAM differential clocks (DDRA\_CKP/N and DDRB\_CKP/N)
  - b. The PMIC disables RANK0 regulators:
    - **LDO5** ( $V_{PP\_DDR}$ )
    - **BUCK6** ( $V_{DD\_DDR}$ )
    - **LDO3** ( $V_{TT\_DDR}$ )
    - $V_{REF\_DDR}$
4. The voltages of the following regulators are discharged through their respective regulator pull-down resistors:
  - **BUCK6** ( $V_{DD\_DDR}$ )
  - **LDO3** ( $V_{TT\_DDR}$ )
  - $V_{REF\_DDR}$ .
5. **LDO5** ( $V_{PP\_DDR}$ ) falls slowly as its discharge pull-down resistor is disabled.

#### 4.1.7 V<sub>DD\_eMMC</sub> power domain (3.3 V)

V<sub>DD\_eMMC</sub> supplies the *eMMC flash memory IC core domain* (V<sub>CC</sub>). The eMMC interface (V<sub>CCQ</sub>) with the related MPU interface (V<sub>DDIO2</sub>) are powered by the 1V8 power domain to work in high speed mode (HS200).

V<sub>DD\_eMMC</sub> is powered from the PMIC LDO2 general purpose linear regulator.

At power-up, the V<sub>DD\_eMMC</sub> regulator is enabled automatically by the PMIC to 3.3 V (see [Section 5.2.1: Power-up triggered by main supply \(V<sub>IN</sub>\) plugin/power-down by software shutdown](#)), enabling the MPU to access the eMMC as boot device peripheral.

V<sub>DD\_eMMC</sub> is enabled in the following modes:

- Run1 mode
- Low power LP-Stop1 mode
- Low power LPLV-Stop1 mode.

*Note:* When no read/write access is expected, the MPU software can disable V<sub>DD\_eMMC</sub>.

V<sub>DD\_eMMC</sub> is disabled in the following modes:

- Run2 mode
- Low power LP-Stop2 mode
- Low power LPLV-Stop2 mode
- Low power Standby mode
- OFF mode.

The PMIC embeds an advanced feature allowing to manage an independent reset of the regulator (the LDO2 in this application) that supplies the boot flash peripheral IC (the eMMC in this application). It allows especially to manage the MPU CPU1 independent reboot in case of a CPU1 crash in addition to manage the [Standby mode](#) exit. See [PMIC power control management independent reset source](#) section for more details.

To control this feature, the MPU NRSTC1MS output is connected to the PWRCTRL3 input of the PMIC. See [PWRCTRL1, PWRCTRL2, PWRCTRL3](#) section for more details.

#### 4.1.8 SD-Card power domains ( $V_{DD\_SDCARD}$ , $V_{DDIO\_SDCARD}$ )

$V_{DD\_SDCARD}$  supplies the SD-Card memory device ( $V_{DD}$ ). The  $V_{DDIO\_SDCARD}$  is dedicated to power the built-in MPU level shifter ( $V_{DDIO1}$ ) and consequently to support SD-Card UHS-I mode.

$V_{DD\_SDCARD}$  (3.3 V) is powered from the PMIC BUCK7 step-down SMPS (3V3 node) via the PMIC LDO7 acting as a power switch (bypass mode).

$V_{DDIO\_SDCARD}$  (3.3 V/1.8 V) is powered from the BUCK7 step-down SMPS (3V3 node) via the PMIC LDO8 settings in:

- Bypass mode, where the LDO8 bypass input voltage (3.3 V) to output voltage.
- LDO mode, where the LDO8 is set at 1.8 V output voltage.

*Note:* The PMIC LDO7 and LDO8 input (LDO78IN) are powered from BUCK7 output (3V3 node). LDO7 or LDO8 are set in bypass mode when  $V_{DD\_SDCARD}$  or  $V_{DDIO\_SDCARD}$  respectively are enabled. They are set in OFF mode when  $V_{DD\_SDCARD}$  or  $V_{DDIO\_SDCARD}$  respectively are disabled. The PMIC bypass mode feature allows excellent power efficiency operation (close to 100%), compared to LDO mode where power efficiency reaches 66% at best ( $V_{OUT}/V_{IN} = 3.3 \text{ V}/5 \text{ V}$ ).

At power-up,  $V_{DD\_SDCARD}$  and  $V_{DDIO\_SDCARD}$  regulators are not started automatically by the STPMIC25A.

*Note:* If the SD-Card is a boot flash peripheral, then the dedicated STPMIC25D reference must be used instead of the STPMIC25A. The STPMIC25D starts LDO7 and LDO8 automatically in bypass mode at power up.

The voltage of the SD-Card data interface ( $V_{DDIO\_SDCARD}$ ) is changed at runtime depending on the speed settings of the SD-Card bus:

- Default bus speed ( $V_{DDIO\_SDCARD} = 3.3 \text{ V}$ ):
  - $V_{DD\_SDCARD}$  is powered by LDO7 set in bypass mode (3.3 V)
  - $V_{DDIO\_SDCARD}$  is powered by LDO8 set in bypass mode (3.3 V)
- UHS-I bus speed ( $V_{DDIO\_SDCARD} = 1.8 \text{ V}$ ):
  - $V_{DD\_SDCARD}$  is powered by LDO7 set in bypass mode (3.3 V)
  - $V_{DDIO\_SDCARD}$  is powered by LDO8 set in LDO mode (1.8 V)

#### SD UHS-I as boot device

As already mentioned in this section, the STPMIC25D is a dedicated reference to automatically starts the LDO7 and the LDO8 in bypass mode at power-up in RANK4. In addition, as eMMC boot flash, the signal NRSTC1MS connected to PWRCTRL3 is used to power cycle the SD-Card regulators (LDO7 and LDO8) to ensure a CPU1 reboot in case of D1 standby exit or a D1 crash. The NRSTC1MS output is connected to the PWRCTRL3 input of the PMIC (see PWRCTRL1, PWRCTRL2, PWRCTRL3 section for details).

*Note:* Alternatively, if the SD-Card device requires to be a boot flash peripheral, the production test software (used in mass production to test and to tune the end-product) must reprogram the STPMIC25A NVM to start LDO7 and LDO8 automatically at power-up in RANK4 (see document [2] for details).

#### 4.1.9 1V8 power domain

1V8 is an analog power supply domain for the MPU, which are:

- PLLs ( $V_{DDA18PLLx}$ )
- USB2 PHY ( $V_{DDA18USB}$ )
- COMBOPHY ( $V_{DDA18COMBOPHY}$ )
- LVDS ( $V_{DDA18LVDS}$ )
- CSI ( $V_{DDA18CSI}$ )
- DSI ( $V_{DDA18DSI}$ )
- ADC/DAC ( $V_{DDA18ADC}$ )
- DDR PHY ( $V_{DDA18DDR}$ ).

The 1V8 power domain is also used to supply power to peripherals such as eMMC ( $V_{CCQ}$ ).

The 1V8 power domain is powered from the PMIC [BUCK5](#) step-down SMPS, which has reduced output voltage ripple across operating conditions.

At power-up, the 1V8 regulator is automatically enabled by the PMIC (See [Section 5.2.1: Power-up triggered by main supply \( \$V\_{IN}\$ \) plugin/power-down by software shutdown](#)).

1V8 is enabled in following modes:

- [Run1 mode](#)
- [Run2 mode](#)
- [Low power LP-Stop1 mode](#)
- [Low power LP-Stop2 mode](#)
- [Low power LPLV-Stop1 mode](#)
- [Low power LPLV-Stop2 mode](#)

1V8 is disabled in the following modes:

- [Low power Standby mode](#)
- $V_{BAT}/OFF$  modes.

#### 4.1.10 MPU backup domain and retention domain

The MPU has two internal power domains to keep critical data and security data in memory (see Figure 2):

- The backup domain supplies:
  - RTC
  - Watchdogs
  - LSE
  - LSI
  - LPSRAM1
  - Retention RAM
  - Backup RAM
  - D3 domain.

They must be retained when  $V_{DDIO}$  is turned off to keep critical data or security. The backup domain is powered in all operating modes, including  $V_{BAT}$  mode where  $V_{BAT}$  is typically powered from a coin cell backup battery.

- The retention domain supplies:
  - Boot
  - Security
  - OTP controller (BSEC)
  - Independent watchdog (IWDG)
  - Resource isolation framework controller (RIFSC and IAC)
  - Debug access port (DAP).

The retention domain is powered in all operating modes, excluding  $V_{BAT}$  mode.

These two domains are powered by either:  $V_{DDCORE}$ ,  $V_{DD}$ , or  $V_{BAT}$  depending on which supply is available and the operating mode of the MPU:

- The backup domain and the retention domain are powered from the  $V_{DDCORE}$  supply in the following modes:
  - Run1 mode
  - Run2 mode
  - Low power LP-Stop1 mode
  - Low power LP-Stop2 mode.
- The backup domain and the retention domain are powered from the  $V_{DD}$  supply via the internal backup regulator (decoupling capacitor on V08CAP pin) in the following modes:
  - Low power LPLV-Stop1 mode
  - Low power LPLV-Stop2 mode
  - Low power Standby mode
- In  $V_{BAT}$  mode, where  $V_{BAT}$  is powered from a backup battery, the internal backup domain is powered from the  $V_{BAT}$  supply via the backup regulator.

*Note:* The retention domain is not powered in  $V_{BAT}$  mode.

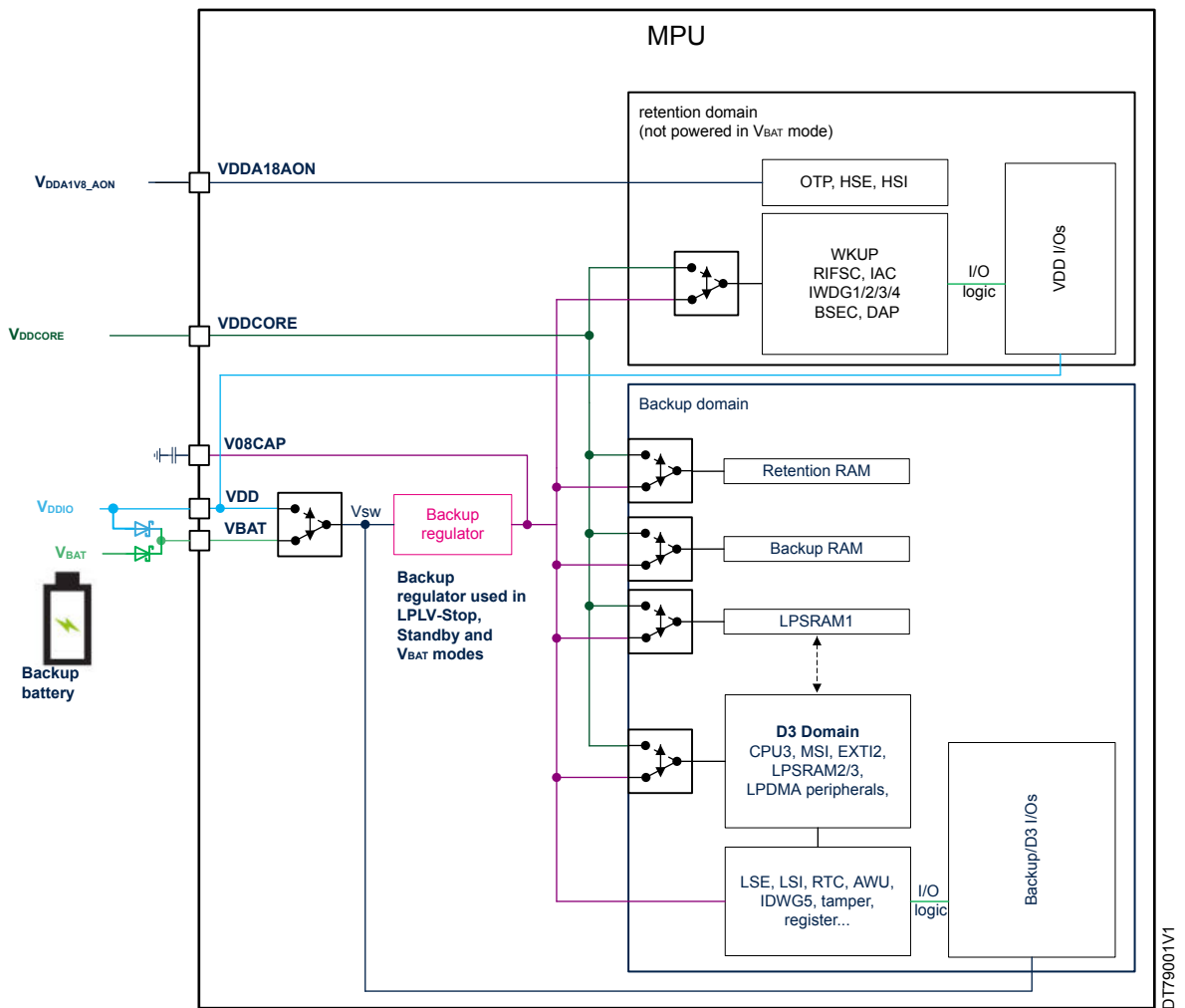
**Figure 2. Backup and retention domain**

For more details on the constraints on  $V_{BAT}$  rise time, refer to the document [5].

#### 4.1.11 3V3 external peripherals power domain

The 3V3 power domain is used to power peripherals around the MPU, such as the display, audio, and so on. It is also used to supply the STPMIC25 LDO7 and LDO8 set in bypass mode in this application to power the SD-Card. 3V3 is powered from the STPMIC25 BUCK7 step-down general purpose SMPS. This regulator is designed to operate up to 2.5 A.

### 4.2 Control signals between STPMIC25 and STM32MP25x

This section outlines the way the STM32MP25x microprocessor communicates with the STPMIC25 device. Several interfaces are available depending on the application requirements.

#### 4.2.1 STPMIC25A and STPMIC25D default behavior with STM32MP25x

The STPMIC25A and STPMIC25D NVM settings are configured to boot the MPU application from flash memory such as eMMC or to boot the MPU from the USB interface. In production, booting from the USB interface is suitable for flashing and then executing the production software and/or the final application software. The default NVM configuration is available in [2] and summarized in the following table.

**Table 4. Default STPMIC25A NVM configuration**

Regulator	Name	Rank	Default output voltage	Default configuration
BUCK1	V <sub>DDCPU</sub>	RANK3	0.8 V	ON_HP
BUCK2	V <sub>DDCORE</sub>	RANK2	0.82 V	ON_HP
BUCK3	V <sub>DDGPU</sub>	RANK0	N/A	OFF
BUCK4	V <sub>DDIO</sub>	RANK1	3.3 V	ON_HP
BUCK5	1V8	RANK3	1.8 V	ON_HP
BUCK6	V <sub>DD_DDR</sub>	RANK0	N/A	OFF
BUCK7	3V3	RANK4	3.3 V	ON_HP
LDO1	V <sub>DDA1V8_AON</sub>	RANK1	1.8 V	ON
LDO2	V <sub>DD_eMMC</sub>	RANK4	3.3 V	ON
LDO3	V <sub>TT_DDR</sub>	RANK0	N/A	OFF
LDO4	V <sub>DD3V3_USB</sub>	RANK5	3.3 V	ON
LDO5	V <sub>PP_DDR</sub>	RANK0	N/A	OFF
LDO6	Free (not used)	RANK0	N/A	OFF
LDO7	V <sub>DD_SDCARD</sub>	RANK0 <sup>(1)</sup>	N/A <sup>(1)</sup>	OFF <sup>(1)</sup>
LDO8	V <sub>DDIO_SDCARD</sub>	RANK0 <sup>(1)</sup>	N/A <sup>(1)</sup>	OFF <sup>(1)</sup>
REFDDR	V <sub>REF_DDR</sub>	RANK0	N/A	OFF

1. For STPMIC25D: RANK4 / bypass mode / ON

In order to start the application, the PMIC regulator start up is spread across five ranks. This is to comply with the MPU power-up sequence constraints and to avoid current peaks on the main power supply. The voltage value of each regulator is defined to fit with the MPU optimum voltage requirements.

#### For safety management

The STPMIC25A and STPMIC25D safety management is set by default in NVM to systematically restarts the application. When a hard fault is detected, the STPMIC25A and STPMIC25D performs a power cycle in the following sequence:

1. reset assertion
2. power down-sequence
3. power-up sequence
4. reset de-assertion to restart the application

Refer to [Section 6: Safety management](#) for more details.

#### PMIC tuning (optional)

The STPMIC25A and STPMIC25D NVM can be reprogrammed by the customer to tune the regulator settings, and the safety management behavior to fit with the MPU based application requirements. This action can be done with the STM32CubeProgrammer.

### 4.2.2 PMIC digital control interface

The PMIC integrates an I<sup>2</sup>C interface, five digital input control pins: PONKEYn, PWRCTRL1/2/3, WAKEUPn, a digital output interrupt pin (INTn), and a bidirectional digital reset pin (RSTn).

#### I<sup>2</sup>C interface

The MPU controls the PMIC via the I<sup>2</sup>C interface to:

- Enable/disable, set the voltage, and operating mode of the regulators.
- Dynamic voltage scaling to switch the MPU in nominal or overdrive modes.
- Set regulators external control for low power mechanisms (PWRCTRLx).
- Set the interrupt controller or read interrupt status.
- Set the protection for the watchdog, overcurrent, undervoltage, or read protection status.
- Tune the PMIC NVM default configuration for the end-product (power-up sequence, safety management).

### **PONKEYn pin (optional)**

The PMIC PONKEYn pin is a digital active low input signal. It is usually connected to a user push button “ON/INT” to power on the application. Thanks to the PMIC built-in pull-up resistor, there is no need for a discrete pull-up resistor on this signal.

The PONKEYn signal allows the following operations:

- Turns on the PMIC (from PMIC OFF state)
- Wakes up the application from a [low-power mode](#) (typically from [Standby mode](#)).
- Forces a switch-off or a power cycling condition with a long press. This duration is programmable as described in [Section 5.1.1: Application turn-on/turn-off conditions](#) .

*Note:* The use of a push “ON/INT” button connected to the PONKEYn is optional as the STPMIC25A and STPMIC25D are automatically turned on when the application is powered.

### **RSTn pin**

The PMIC RSTn pin must be connected to the MPU NRST pin. It can also be connected to a “RESET” user push button. This pin has built-in pull-up resistor ; so no additional discrete pull-up resistor is needed on this signal. Nevertheless, a 10 nF capacitor to GND is required to be placed as close as possible to the MPU NRST pin. This is specifically required to avoid EMI/ESD coupling as there is no debounce circuitry in neither the MPU, nor the PMIC.

The PMIC RSTn pin is a digital active low bidirectional signal with a built-in pull-up resistor:

- When PMIC asserts an RSTn (such as during the power-up or the power-down sequence), it drives the MPU NRST signal low (open drain). The MPU is forced into a system reset until the PMIC releases the RSTn.
- When the MPU asserts an NRST signal such as an MPU watchdog event, or by pressing the “RESET” button, the PMIC immediately asserts the RSTn pin and performs a noninterruptible power cycle. The PMIC performs a power down sequence, followed by a power-up sequence and releases the RSTn.

At the end of the power-cycle sequence, the PMIC waits for the MPU NRST signal to go high before rearming the reset detection mechanism to avoid infinite loop reset.

### **INTn signal**

The PMIC INTn pin is a digital output (open drain) active low interrupt line connected to the MPU PA0 input pin. This pin has built-in pull-up resistor. Therefore, no additional discrete pull-up resistor is needed on this signal

PA0 has both interrupt and wake-up capability:

- To manage an interrupt from the PMIC when the MPU operates in either [Run1](#), [Run2](#) mode or a [low power mode](#) (except [Standby mode](#)).
- To wake up the MPU when it operates in [Standby mode](#).

### **PWRCTRL1, PWRCTRL2, PWRCTRL3**

The PMIC has three power control digital input signals connected to dedicated MPU control signals.

Each PMIC regulator is controlled from a single PWRCTRL signal typically:

- To switch ON or OFF
- To change the output of a regulator depending on the PWRCTRL signal state.

Alternatively, a PWRCTRL signal can be set to reset a regulator at a value defined in STPMIC25A NVM (see document [\[2\]](#) for details)

MPU power control connection to PMIC:

- The MPU `PWR_ON` output pin controls the PMIC `PWRCTRL1` input pin. Figure 1 illustrates how the MPU `PWR_ON` output pin controls the PMIC `PWRCTRL1` input pin. The MPU `PWR_ON` pin is internally multiplexed between either `PWR_ON` or `PWR_LP` signal. This means that `PWR_D2CR[LPCFG_D2]` must be set to 1 by the software after a system reset:
  - `PWR_ON` pin is multiplexed with `PWR_LP` signal to manage LP-Stop1/LP-Stop2 or LPLV-Stop1/LPLV-Stop2 modes
  - `PWR_ON` pin is multiplexed with `PWR_ON` signal (default) to manage Standby mode
- The MPU `PWR_CPU_ON` output pin controls the PMIC `PWRCTRL2` pin. In the application illustrated in Figure 1, the MPU `PWR_CPU_ON` controls the MPU D1 domain ( $V_{DDCPU}$ ) when this domain is in DStandby (see [3] for more details) set in Run2, LP-Stop2 mode, LPLV-Stop2 mode and Standby mode. The internal MPU `pwr_cpu_on` signal can also be multiplexed with the internal MPU `pwr_cpu_lp` signal. To do this, the `PWR_D1CR[LPCFG_D1]` must be set to 0 by the software after a system reset. This keeps the `PWR_CPU_ON = 1` in LP-Stop1 mode and LPLV-Stop1 mode.
- The MPU `NRSTC1MS` pin controls the PMIC `PWRCTRL3` pin. `NRSTC1MS` pin is used to control the power supplies of the external flash. This power is required to carry out the first level boot of CPU1. To ensure the platform is rebooted, a full power cycle must be applied to the mass storage boot flash memory such as eMMC or SD-Card when used as boot flash memory with the STPMIC25D. The `NRSTC1MS` pin is activated when a system reset, or D1 reset (D1 Standby mode exit) is generated. In this application, the `NRSTC1MS` is linked to MPU `PWR_CPU_ON` by a 10 k $\Omega$  pull-up resistor. This is illustrated in Figure 1.

See Section 5.1.2: PMIC power control management (`PWRCTRLx`) for more details about PMIC `PWRCTRL` settings.

#### WAKEUPn (optional)

The `WAKEUPn` signal is driven by the MPU PC13 (`RTC_OUT1`) pin to control the PMIC `WAKEUPn` pin. It allows the MPU to trigger a PMIC turn-on condition, from PMIC OFF state, or in MPU  $V_{BAT}$  mode, typically when the real-time clock timer elapses.

This is done by using the PMIC built-in pull-up resistor, therefore a discrete pull-up resistor is not required on this signal.

## 5 Power management

### 5.1 Operating modes

The application can switch to different operating modes depending on the system activity. The MPU manages the operating modes and they control the power management as detailed in [4]. The operating modes are described in the table below.

**Table 5. Operating modes**

Operating mode	PMIC state	PWR_ON	PWR_CPU_ON	NRSTC1MS <sup>(1)</sup>	Description	Notes
Run1	POWER_ON	1	1	1	VDDIO power on	The difference between Run1/2 and Stop1/2 mode is only based on the STM32MP25x clock management and they have no impact on power management.
					VDDCORE power on	
					VDDCPU power on (in normal or overdrive voltage)	
					VDDGPU controlled by software	
					System clock on	
					Peripherals power on/off	
DDR4 active						
Run2	POWER_ON	1	0	0	VDDIO power on	
					VDDCORE power on	
					VDDCPU power off	
					VDDGPU power off by software	
					System clock on	
					Peripherals power on/off	
DDR4 active						
LP-Stop1 mode	POWER_ON	0	1	1	VDDIO power on	-
					VDDCORE power on	
					VDDCPU power on (in normal voltage)	
					VDDGPU controlled by software	
					System clock off	
					Peripherals power on/off	

Operating mode	PMIC state	PWR_ON	PWR_CPU_ON	NRSTC1MS <sup>(1)</sup>	Description	Notes
LP-Stop1 mode	POWER_ON	0	1	1	DDR4 self-refresh with V <sub>TT_DDR</sub> power off	-
LP-Stop2 mode	POWER_ON	0	0	0	V <sub>DDIO</sub> power on V <sub>DDCORE</sub> power on V <sub>DDCPU</sub> power off V <sub>DDGPU</sub> power off by software System clock off Peripherals power on/off DDR4 self-refresh with V <sub>TT_DDR</sub> power off	-
LPLV-Stop1 mode	POWER_ON	0	1	1	V <sub>DDIO</sub> power on V <sub>DDCORE</sub> power on at lower voltage. V <sub>DDCPU</sub> power on in nominal voltage V <sub>DDGPU</sub> controlled by software System clock off Peripherals power on/off DDR4 self-refresh with V <sub>TT_DDR</sub> power off	In the application specified in Figure 1, the MPU PWR_ON signal is internally muxed with the MPU PWR_LP signals so PWR_ON is low in: <ul style="list-style-type: none"> <li>• LPLV-Stop1 mode</li> <li>• LPLV-Stop2 mode</li> <li>• Standby mode</li> </ul> If this multiplexing does not occur, the PWR_ON signal is
LPLV-Stop2 mode	POWER_ON	0	0	0	V <sub>DDIO</sub> power on V <sub>DDCORE</sub> power on at lower voltage. V <sub>DDCPU</sub> power off V <sub>DDGPU</sub> power off by software System clock off Peripherals power on/off DDR4 self-refresh with V <sub>TT_DDR</sub> power off	<ul style="list-style-type: none"> <li>• high in:               <ul style="list-style-type: none"> <li>– LPLV-Stop1 mode</li> <li>– LPLV-Stop2 mode</li> </ul> </li> <li>• low only in Standby mode.</li> </ul>
Standby mode	POWER_ON	0	0	0	V <sub>DDIO</sub> power on	-

Operating mode	PMIC state	PWR_ON	PWR_CPU_ON	NRSTC1MS <sup>(1)</sup>	Description	Notes
(Standby mode (DDR4 in self-refresh) Standby mode (DDR4 OFF))	POWER_ON	0	0	0	V <sub>DDCORE</sub> power off	-
					V <sub>DDCPU</sub> power off	
					V <sub>DDGPU</sub> power off by software	
					System clock off	
					Peripheral power off	
					DDR4 self-refresh or off with V <sub>TT_DDR</sub> power off	
V <sub>BAT</sub>	NO_SUPPLY	-	-	-	Backup domain powered from backup battery	-
OFF	OFF	-	-	-	All regulators are powered off Backup domain powered from backup battery if present	-

1. In this application, the NRSTC1MS is linked to MPU PWR\_CPU\_ON by a pull-up. When the MPU PWR\_CPU\_ON is low, the NRSTC1MS is also low.

### 5.1.1 Application turn-on/turn-off conditions

The PMIC autonomously manages the power-up and the power-down sequence when respectively a turn-on or a turn-off condition occurs.

The STPMIC25A and STPMIC25D automatically powers up when the application is powered from a valid power source: When V<sub>IN</sub> rises above the V<sub>INOK\_rise</sub>, it triggers a PMIC turn-on condition as the “AUTO turn-on” bit is set by default in the STPMIC25A and STPMIC25D NVM. The V<sub>INOK\_rise</sub> is the PMIC internal threshold (see [2] for the values).

#### Turn-on conditions

When the application is in OFF mode (PMIC in the OFF state with V<sub>IN</sub> present), a turn-on condition is required to power up the PMIC, and then to run the application. Similarly, if the application needs to go into power-off mode, a turn-off condition is required to power-down the PMIC.

If the PMIC is in OFF state, it is powered up by one of the three triggers described in the table below:

**Table 6. PMIC turn-on conditions**

Condition	Trigger	Description
AUTO turn-on	Internal	The STPMIC25 starts automatically when V <sub>IN</sub> rises above V <sub>INOK_rise</sub> . This feature is set by default in the STPMIC25A and STPMIC25D NVM. (see “AUTO turn-ON” section in [2] for details)
PONKEY user button	External	PONKEYn pin voltage falling edge
Wake-up events from the STM32MP25x to PMIC WAKEUPn pin	External	WAKEUPn pin voltage falling edge

After a turn-on condition, the PMIC carries out a transitional power-up sequence as described in Section 5.2: Application Power-up/Power-down sequence.

### Turn-off conditions

A turn-off condition leads the PMIC to perform a power-down sequence to go into one of the following states:

- The **OFF** state
- The **FAIL\_SAFE\_LOCK** state (see [2] for the definition).
- Automatic restart (power cycle).

This depends on whether the source is a software switch-off or a hard fault that has triggered the turn-off condition (see detailed about hard fault is [Section 6: Safety management](#)). The turn-off conditions are described in the table below.

**Table 7. PMIC turn off conditions**

Condition	Hard fault	Description
Software switch OFF	NO	I <sup>2</sup> C commands "SWOFF" sent by the MPU to the PMIC <sup>(1)</sup>
PONKEY user button	YES	PONKEYn signal is asserted for 10 s (See <a href="#">Section 6.2.5: PKEY: power on key user button long press</a> )
V <sub>IN</sub> undervoltage	YES	V <sub>IN</sub> voltage falls below the PMIC V <sub>INOK_fall</sub> threshold. <sup>(2)</sup> (See <a href="#">Section 6.2.2: V<sub>IN</sub> undervoltage protection (V<sub>IN</sub> &lt; V<sub>INOK_Fall</sub>)</a> )
Thermal shutdown	YES	PMIC temperature rises above T <sub>SHDN_Rise</sub> threshold <sup>(3)</sup> (See <a href="#">Section 6.2.3: TSHDN: thermal shutdown protection</a> )
Overcurrent protection	YES	Overcurrent or short-circuit on predefined regulators (See <a href="#">Section 6.2.1: OCP overcurrent protection</a> )
Watchdog	YES	PMIC watchdog timer elapsed <sup>(4)</sup> (See <a href="#">Section 6.2.4: WDG: watchdog timer expiration</a> )

1. The PMIC goes in a transitional power-down state. It then goes and stays in OFF state until a turn-on condition is met. If the restart request bit (RREQ\_EN) is set with the SWOFF bit, the PMIC restarts automatically
2. If restart conditions are met, the PMIC waits for the V<sub>IN</sub> voltage to rise above the V<sub>INOK\_rise</sub> threshold before powering up.
3. If restart conditions are met, the PMIC waits for the temperature to decrease below T<sub>SHDN\_Fall</sub> before powering up.
4. The watchdog timer is not enabled by default.

**Note:** The PMIC restarts automatically after a turn-off condition is triggered by a hard fault source (behavior programmed by default in the STPMIC25A and STPMIC25D NVM).

### 5.1.2 PMIC power control management (PWRCTRLx)

The PMIC PWRCTRLx signals are dedicated to managing MPU power modes or special regulator reset features. These signals must be correctly configured, and this before entering into low power mode, to ensure proper MPU low power mode entry and exit transitions.

The PMIC PWRCTRLx signals are all independently controlled and each signal controls a PMIC regulator by setting the appropriate registers as described in [2]. As such, it is possible to define:

- The control source selection of the regulator (PWRCTRL1/2/3)
- The polarity of the respective PWRCTRLx signals, which are used to define if the signals are active low or active high.

**Note:** One of these power controls can be used to switch the PMIC state machine from *Run1* or *Run2* to *Standby mode* and another one can be used to suspend the PMIC watchdog, such as when the application is in low power mode.

A PMIC PWRCTRL signal aims to switch between two regulator control registers xxxx\_MAIN\_CR and xxxx\_ALT\_CR.

Typically, when a PWRCTRL signal goes to a low state, the PMIC internally switches from the main control register (MAIN) content to the alternate (ALT) control register content and vice versa.

### PMIC power control management for Standby mode

When the [Standby mode](#) is requested, the PMIC state machine must switch to STANDBY state to reach the minimum quiescent current consumption. For this operation, the PMIC uses the PWRCTRL, which is dedicated to ensure the state machine transition from PMIC STANDBY to RUN state and vice versa. The STANDBY\_PWRCTRL\_SEL[1:0] bit sets the PWRCTRL selection.

When the MPU runs in [Standby mode](#), the consumption must be drastically reduced. The BUCK4 ( $V_{DDIO}$ ) must be set to low power mode (LP) instead of the high power mode (HP) (see [2] for details). When this feature is set to a BUCK step down regulator, its performance is reduced, meaning the accepted BUCK rated output current is lowered, and clock synchronization is internally disabled.

Else in other MPU low power modes, the BUCK step down regulator works in high power mode (HP mode). See [2] for details.

### PMIC power control management independent reset source

The PWRCTRL\_RST bit is used to enable the regulator independent reset source. When this bit is set, it behaves in either of the conditions below:

- If PWRCTRL is deasserted, the regulator operates according to xxxx\_MAIN\_CR .
- If PWRCTRL is asserted, the regulator is disabled and the xxxx\_MAIN\_CR and xxxx\_ALT\_CR are reset to the default value defined in the NVM. On PWRCTRL deassertion , the regulator operates according to xxxx\_MAIN\_CR NVM reset content.

This feature is specifically suitable to reset application with flash memories in case of D1 crash (see [Section 5.4.2: CPU1 crash recovery management](#) ). In this application, the regulator independent reset source is activated by the PWRCTRL3 (MPU NRSTC1MS) and mapped to:

- LDO2 ( $V_{DD\_eMMC}$ ): STPMIC25A and STPMIC25D
- LDO7 ( $V_{DD\_SDCARD}$ ): STPMIC25D
- LDO8 ( $V_{DDIO\_SDCARD}$ ): STPMIC25D

### 5.1.3 PMIC mask-reset option

If the application needs to have one or several PMIC regulators enabled while the PMIC performs a reset sequence, the MPU bootloader software must program the PMIC mask reset option by setting:

- The PMIC BUCKS\_MRST\_CR register to target BUCK converters
- The PMIC LDOS\_MRST\_CR register to target LDO regulators

A reset sequence is triggered after the PMIC RSTn signal asserted by the MPU or the user reset push button. Refer to [2] for details on the PMIC mask-reset option.

This is typically the case for the BUCK4 powering the MPU  $V_{DDIO}$  power domains and the LDO1 powering the MPU  $V_{DDA1V8\_AON}$  power domain. The power cycle on  $V_{DDIO}$  and on  $V_{DDA1V8\_AON}$  must be masked by setting these two PMIC registers:

- BUCKS\_MRST\_CR [3] = 1
- LDOS\_MRST\_CR [0] = 1

This prevents losing the content in:

- The MPU backup RAM
- The MPU retention RAM
- The MPU backup register content
- The JTAG debug interface included in the OTP controller, see [Figure 2](#)

*Note:* The MPU software bootloader must program these settings using I<sup>2</sup>C commands to the PMIC, following each application power-up. The content of BUCKS\_MRST\_CR, and LDOS\_MRST\_CR is reset at the end of a PMIC reset cycle.

## 5.2 Application Power-up/Power-down sequence

The power up sequence is the transition managed by the STPMIC25A from application power-off to application Run mode.

The power down sequence is the transition managed by the STPMIC25A from application Run mode to application power-off.

The application power-up and power-down sequence shown in [Figure 3](#) is based on the reference designed in [Figure 1](#).

### 5.2.1 Power-up triggered by main supply ( $V_{IN}$ ) plugin/power-down by software shutdown

When the application is connected to an external power supply, the PMIC powers-up automatically when  $V_{IN}$  rises above the STPMIC25A  $V_{INOK\_rise}$  threshold. When the power-up ends, the PMIC release the NRST signal.

*Note:* The STPMIC25A has the `AUTO_TURN_ON` enabled by default in NVM settings.

Once the NRST signal is released, the MPU boots (including the DDR4 initialization by the MPU software). The MPU reaches system Run mode.

*Note:* When the PMIC is powered-up, the `PWRCTRLx` signals have no effect, they are not initialized.

When the MPU software sends the "SWOFF" command to the PMIC, a turn-off condition occurs, the PMIC enters power-down, and then goes into the OFF mode.

The above sequence is detailed below and illustrated in [Figure 3](#):

1. The application has no power or the MPU is powered by the onboard coin cell  $V_{BAT}$ . The  $V_{BAT}$  supplies the MPU backup domain.
2. A power supply is connected to the application.  $V_{IN}$  voltage rises.
3. Once  $V_{IN}$  voltage is above  $V_{INPOR\_Rise}$  (STPMIC25A  $V_{INPOR\_Rise} = 2.3$  V typ.) threshold:
  - a. The PMIC goes to the `INIT&LOAD` transitional state to preload its NVM contents and checks its integrity.
  - b. If the PMIC NVM integrity is valid, the STPMIC25A initializes, and its state machine goes directly in the `CHECK&LOAD` state as the `AUTO_TURN_ON` bit is set in the NVM. This is defined in the [Turn-on conditions](#) section.

*Note:* The PMIC `INIT&LOAD` and `CHECK&LOAD` have a typical duration of approximately 6 ms.

4. Once the `CHECK&LOAD` states ends and the  $V_{IN}$  supply rises above  $V_{INOK\_rise}$ <sup>(1)</sup>, the PMIC starts a power-up sequence. The STPMIC25A regulators follow the power-up sequence predefined in the NVM:
  - a. RANK1 (1.5 ms): The `BUCK4` ( $V_{DDIO}$ ) is enabled at 3.3 V and the `LDO1` ( $V_{DDA1V8\_AON}$ ) is enabled at 1.8 V. Once  $V_{DDIO}$  voltage rises above MPU  $V_{POR}$  threshold (1.67 V), and  $V_{DDA1V8\_AON}$  voltage rises above MPU  $V_{POR\_ANA}$  threshold (1.67 V), the MPU  $t_{RSTTEMPO}$  (440  $\mu$ s typ.) delay is applied. Once  $t_{RSTTEMPO}$  elapses, the MPU enters in system reset. After approximately 230  $\mu$ s needed to ensure internal initialization, the MPU releases the internal `nrst_por`. The MPU then goes into system reset and the `PWR_ON` signal goes high.

*Note:* NRST signal is kept low as the PMIC asserts the NRST signal until the end of the power-up sequence.

- b. RANK2 (1.5 ms): The `BUCK2` ( $V_{DDCORE}$ ) is enabled at 0.82 V. Once  $V_{DDCORE}$  voltage rises above MPU  $V_{RDY\_VDDCORE}$  threshold (0.66 V), an MPU  $T_{delay\_VDDCORE}$  (400  $\mu$ s typ.) delay is started to allow  $V_{DDCORE}$  voltage to reach minimum operating voltage. Once  $T_{delay\_VDDCORE}$  elapses, the MPU starts hardware initialization, such as starting the HSI oscillator and so on. The `PWR_CPU_ON` signal goes high.
  - c. RANK3 (1.5 ms): The `BUCK1` ( $V_{DDCPU}$ ) is enabled at 0.80 V and the `BUCK5` (1V8) is enabled at 1.8 V. Once  $V_{DDCPU}$  voltage rises above MPU  $V_{RDY\_VDDCPU}$  threshold (0.66 V), a MPU  $T_{delay\_VDDCPU}$  (400  $\mu$ s typ.) delay is started to allow  $V_{DDCPU}$  voltage to reach minimum operating voltage. Once  $T_{delay\_VDDCPU}$  elapses, the MPU is ready to boot, and is keeps in reset until the PMIC releases the NRST signal.
  - d. RANK4 (1.5 ms): The `BUCK7` (3V3) and `LDO2` ( $V_{DD\_eMMC}$ ) are enabled at 3.3 V.

*Note:* The STPMIC25D enables the `LDO7` ( $V_{DD\_SDCARD}$ ) and the `LDO8` ( $V_{DDIO\_SDCARD}$ ) in bypass mode allowing to boot over SD-Card UHS-I. See [Section 4.1.8: SD-Card power domains](#) ( $V_{DD\_SDCARD}$ ,  $V_{DDIO\_SDCARD}$ ).

- e. RANK5 (1.5 ms): `LDO4` ( $V_{DD3V3\_USB}$ ) is enabled at 3.3 V.
  - f. Once RANK5 is ended, the PMIC releases the `RSTn` that releases MPU NRST.
5. Once the NRST is released, the MPU enters in Run mode:
  - a. The MPU releases the `NRSTC1MS` signal.
  - b. The D1 CPU starts to execute the boot ROM: The `EADLY` timer starts. Refer to [STM32MP25x internal timer for low power mode management](#) for more information.
  - c. Once the `EADLY` timer elapses, the boot ROM reads, verifies, and executes the bootloader from the external flash memory (eMMC).

6. The bootloader software performs all the initializations, then loads and executes the application software:
  - a. The software enables LDO5 ( $V_{PP\_DDR}$ ) at 2.5 V.
  - b. The software waits for 1 ms.
  - c. The software enables the following once the delay has elapsed:
    - i. REFDDR ( $V_{REF\_DDR}$ )
    - ii. LDO3 ( $V_{TT\_DDR}$ ) in sink-source mode
    - iii. BUCK6 ( $V_{DD\_DDR}$ ) at 1.2 V.
  - d. The software waits for 1 ms.
  - e. The MPU software initializes the DDR4 controller and DDR memory ICs.
  - f. The bootloader loads the application software into DDR4 and executes it and the kernel initializes.
  - g. The system is now running. The application software can enable the GPU on BUCK3 ( $V_{DDGPU}$ ) and the SD-Card on the LDO7 ( $V_{DD\_SDCARD}$ ) and the LDO8 ( $V_{DDIO\_SDCARD}$ )
7. When a shutdown request occurs, the software prepares to power-off properly:
  - a. The software shuts down the DDR4 regulators in the following sequence:
    - i. Disable in sequence:
      1. BUCK6 ( $V_{DD\_DDR}$ )
      2. LDO3 ( $V_{TT\_DDR}$ )
      3. REFDDR ( $V_{REF\_DDR}$ ).
    - ii. The software waits 1 ms.
    - iii. Disable LDO5 ( $V_{PP\_DDR}$ ).
  - b. The software sends the *SWOFF* command to the PMIC by I<sup>2</sup>C to trigger a turn-off condition .
8. The PMIC performs a power-down sequence:
  - a. The PMIC asserts the RSTn, asserting the MPU NRST signal.
  - b. RANK0 (1.5 ms): BUCK3 ( $V_{DDGPU}$ ), LDO7 ( $V_{DD\_SDCARD}$ ), LDO8 ( $V_{DDIO\_SDCARD}$ ) are disabled. If not disabled by software, BUCK6 ( $V_{DD\_DDR}$ ), LDO3 ( $V_{TT\_DDR}$ ), REFDDR ( $V_{REF\_DDR}$ ), and LDO5 ( $V_{PP\_DDR}$ ) are disabled.
  - c. RANK5 (1.5 ms): LDO4 ( $V_{DD3V3\_USB}$ ) is disabled.
  - d. RANK4 (1.5 ms): BUCK7 (3V3) and LDO2 ( $V_{DD\_eMMC}$ ) are disabled.
  - e. RANK3 (1.5 ms): BUCK1 ( $V_{DDCPU}$ ), and BUCK5 (1V8) are disabled.
  - f. RANK2 (1.5 ms): BUCK2 ( $V_{DDCORE}$ ) is disabled. Once the  $V_{DDCORE}$  voltage drops below MPU  $V_{RDY\_VDDCORE}$  falling threshold, the MPU PWR\_CPU\_ON signals go low.
  - g. RANK1 (1.5 ms): BUCK4 ( $V_{DDIO}$ ) and LDO1 ( $V_{DDA1V8\_AON}$ ) are disabled . Once the  $V_{DDIO}$  drops below the MPU  $V_{PDR}$  threshold or the  $V_{DDA1V8\_AON}$  drops below  $V_{PDR\_ANA}$  threshold, the MPU enters in power-on reset mode. The PWR\_ON and the PWR\_CPU\_ON I/Os go in high-Z pull-down.
9. The PMIC is now in OFF mode: the application is powered off.
  1. For the STPMIC25A the  $V_{INOK\_rise}$  is typically 4 V.



### PWR\_ON and PWR\_CPU\_ON signals behavior during the power-up sequence

During the power-up sequence, the PMIC **PWRCTRL1/2** internal pull-up resistors, and the MPU **PWR\_ON** and the MPU **PWR\_CPU\_ON** internal pull-down resistors induce a particular artifact on the **PWR\_ON** and **PWR\_CPU\_ON** signals of the application. See [Figure 4](#) for details.

This artifact has no impact on the system behavior as **PWRCTRLx** signals are only probed by PMIC once the application software is initialized and the PMIC **PWRCTRLx** signals are allocated to regulators.

*Note:* The following sequence is to be read with [Figure 4](#). The numbers in the list correspond to the number in [Figure 4](#)

1. The PMIC **PWRCTRL1** and **PWRCTRL2** internal pull-ups (80 kΩ typical) are active until the  $V_{DDIO}$  and  $V_{DDA1V8\_AON}$  start.
2. After few micro seconds, the MPU **PWR\_ON/PWR\_CPU\_ON** I/Os are in high-Z and internal pull-down resistor (40 kΩ typical) is activated on both signals. A resistor divider is formed by the two 80 kΩ pull-up resistors in the PMIC and 40 kΩ pull-down in the MPU. This resistor divider applies to the **PWR\_ON** and **PWR\_CPU\_ON** application signals respectively. Both voltages follow the  $V_{DDIO}$  rising voltage driven by PMIC **PWRCTRLx** pull-up resistors.
3. During approximately 800 μs ( $V_{DDIO}$  rise time, together with  $t_{RSTTEMPO}$  and internal MPU initialization), the MPU internal pull-down and the PMIC internal pull-up are still active, so the  $V_{DDIO}$  voltage is divided by the resistor divider ratio.
4. The MPU internal resistors on **PWR\_ON** and **PWR\_CPU\_ON** are deactivated and MPU **PWR\_ON** and **PWR\_CPU\_ON** pads are internally set in push-pull mode. **PWR\_ON** and **PWR\_CPU\_ON** signals are immediately driven by the MPU to the expected level: **PWR\_ON** goes high and **PWR\_CPU\_ON** is kept low until the  $V_{DDCORE}$  raises.

*Note:* PMIC **PWRCTRLx** pull-up resistors remain active and must be disabled by the bootloader software, after each the application powered-up to avoid extra power consumption in low power mode. This is when the **PWR\_ON** and/or **PWR\_CPU\_ON** level is low.

**Figure 4. Application PWR\_ON and PWR\_CPU\_ON behavior during the power-up sequence**

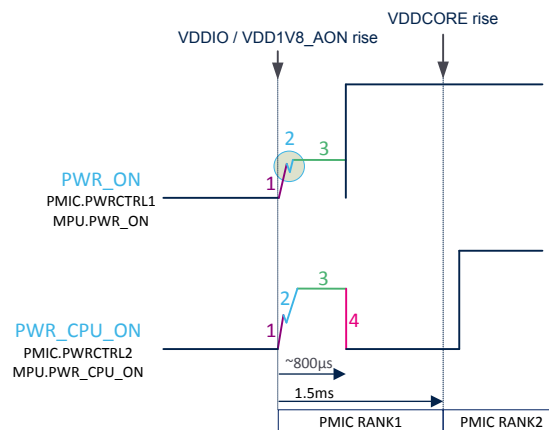

DT79903V1

### PWRCTRLs behavior during the power down sequence

During the power down sequence, the PMIC **PWRCTRL1/2** internal pull-up resistor and the MPU **PWR\_ON** and **PWR\_CPU\_ON** internal pull-down resistors induce a particular artifact on the **PWR\_ON** and **PWR\_CPU\_ON** signals of the application. The whole process is illustrated in [Figure 5](#).

*Note:* This artifact has no impact on the system behavior as **PWRCTRLx** signals are not probed by PMIC until the application software initializes and allocates the PMIC **PWRCTRLx** signals to regulators.

The following sequence is to be read with [Figure 5](#). The numbers in the list correspond to the number in [Figure 5](#).

1. Once the  $V_{DDCORE}$  voltage drops below  $V_{RDY\_VDDCORE}$  falling threshold, the MPU **PWR\_CPU\_ON** is deactivated and the MPU **PWR\_ON** remains active. MPU **PWR\_ON** and **PWR\_CPU\_ON** pads are kept in push-pull mode.

2. Once  $V_{DDIO}$  drops below the  $V_{PDR}$  threshold, or  $V_{DDA1V8\_AON}$  drops below the  $V_{PDR\_ANA}$  threshold, the MPU  $PWR\_ON$  and  $PWR\_CPU\_ON$  I/O pads go in Hi-Z driven with internal pull-down resistor (40 k $\Omega$  typ.). The PMIC  $PWRCTRL1$  and  $PWRCTRL2$  pad internal pull-up resistors (80 k $\Omega$  typ) are still present. A resistor divider is formed of two 80 k $\Omega$  pull-up resistors in the PMIC and 40 k $\Omega$  pull-down in the MPU and applies to the respective  $PWR\_ON$  and  $PWR\_CPU\_ON$  application signals. Both voltages follow  $V_{DDIO}$  falling voltage driven by the PMIC  $PWRCTRLx$  pull-up resistors.
3. In this state, the PMIC pull-up resistors are still present, but the MPU pull-down resistors are deactivated. Both  $PWR\_ON$  and  $PWR\_CPU\_ON$  voltages follow  $V_{DDIO}$  falling voltage driven by PMIC  $PWRCTRLx$  pull-up resistors.

**Figure 5. Application  $PWR\_ON$  and  $PWR\_CPU\_ON$  behavior during power down sequence**

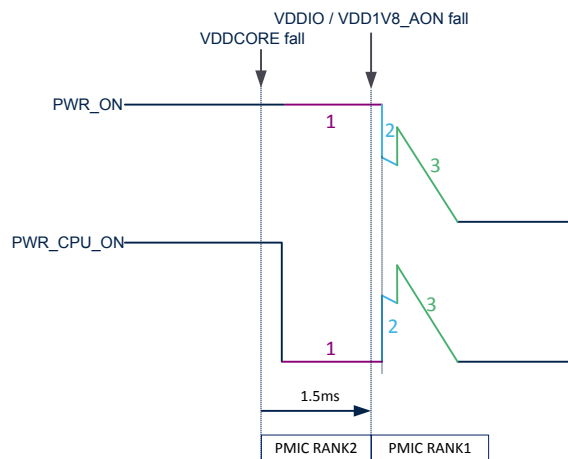

DT79904V1

### 5.2.2 Power-down triggered by fast $V_{IN}$ drop

The application in Figure 1 is initially running as illustrated in step 6 of Figure 3. The main supply voltage  $V_{IN}$  is removed, causing a drop in  $V_{IN}$ . The drop in  $V_{IN}$  triggers a PMIC turn off condition ( $V_{INOK\_fall}$ ), as a result the PMIC starts a power-down sequence. Then  $V_{IN}$  voltage goes below PMIC  $V_{INPOR\_fall}$  threshold. As the PMIC is in internal reset, all power supplies drop down in an uncontrolled sequence. Then the main supply voltage is connected back restarting the system once again.

The above sequence is detailed below and illustrated in Figure 6:

1. The application is initially running with a valid main supply voltage ( $V_{IN}$ )
2. The main supply is removed and  $V_{IN}$  starts to drop
3. Once the  $V_{IN}$  voltage is below PMIC  $V_{INOK\_fall}$  threshold (STPMIC25A  $V_{INOK\_fall} = 3.5V$ ), a turn-off condition occurs and the PMIC starts the power-down sequence:
  - a. The PMIC asserts the  $RSTn$ , asserting the MPU  $NRST$  signal.
  - b. RANK0 (1.5 ms): The following regulators are disabled:
    - BUCK3 ( $V_{DDGPU}$ )
    - LDO7 ( $V_{DD\_SDCARD}$ )
    - LDO8 ( $V_{DDIO\_SDCARD}$ )
    - LDO5 ( $V_{PP\_DDR}$ )
    - BUCK6 ( $V_{DD\_DDR}$ )
    - LDO3 ( $V_{TT\_DDR}$ )
    - REFDDR ( $V_{REF\_DDR}$ )
  - c. RANK5 (1.5 ms): LDO4 ( $V_{DD3V3\_USB}$ ) is disabled

4. Once the  $V_{IN}$  voltage drops below PMIC  $V_{INPOR\_Fall}$  threshold (STPMIC25A  $V_{INPOR\_Fall} = 2.1\text{ V}$ ), the PMIC enters internal reset. The power-down sequence is stopped, all regulators are disabled with all regulators output discharge disabled, and the PMIC releases the NRST signal. The system enters in an uncontrolled power-down sequence. All power domains voltages drop with uncontrolled slew rate (depends on load and decoupling capacitors on related power domain):
  - a. Once the PMIC releases the NRST signal, the NRST signal rises following VDDIO voltage as both VDDIO and VDDA1V8\_AON voltage are above respectively MPU  $V_{PDR}$  and  $V_{PDR\_ANA}$  falling thresholds.
  - b. The NRSTC1MS signal follows NRST signal.
  - c. Once the VDDCORE voltage is below MPU  $V_{RDY\_VDDCORE}$  falling threshold, the MPU PWR\_CPU\_ON signal goes low and the MPU NRSTC1MS follows the MPU PWR\_CPU\_ON signal.
  - d. Once the VDDIO voltage is below MPU  $V_{PDR}$  threshold or the VDDA1V8\_AON is below  $V_{PDR\_ANA}$  threshold, the MPU enters in power-on reset mode:
    - The MPU assert the NRST signal and the NRST signal goes low
    - The NRSTC1MS goes floating
    - The PWR\_ON and the PWR\_CPU\_ON I/Os go in high-Z pull-down. The PWR\_ON signal goes low and the NRSTC1MS is tied by voltage divider between internal pull down and external pull resistor connected to PWR\_CPU\_ON signal.
    - Once VDDIO is below approximately 1 V, the MPU NRST, NRSTC1MS, PWR\_ON, PWR\_CPU\_ON have uncontrolled voltage.
5. As soon as a power supply is connected to the application, the  $V_{IN}$  voltage rises. Once  $V_{IN}$  voltage is above  $V_{INPOR\_Rise}$  (STPMIC25A  $V_{INPOR\_Rise} = 2.3\text{V typ.}$ ) threshold:
  - a. The PMIC goes to the INIT&LOAD transitional state to preload its NVM content and checks its integrity.
  - b. If the PMIC NVM integrity is valid, the PMIC goes into the CHECK&LOAD state, as the AUTO\_TURN\_ON bit is set in the STPMIC25A NVM.
  - c. Once the PMIC enters in the CHECK&LOAD state, output discharge is enabled on all regulators. This allows the discharge of any remaining voltage on all regulators output before the PMIC starts the power-up sequence.

*Note:* The PMIC INIT&LOAD and CHECK&LOAD have a typical duration of approximately 6 ms.

6. Once the *CHECK&LOAD* state ends and the  $V_{IN}$  supply rises above  $V_{INOK\_rise}$  (STPMIC25A  $V_{INOK\_rise} = 4\text{ V}$  typ.), the PMIC starts a power-up sequence. The PMIC regulators follow the power-up sequence predefined in its NVM:

a. RANK1 (1.5 ms): The following regulators are enabled:

- BUCK4 (VDDIO) is enabled at 3.3 V
- LDO1 (VDDA1V8\_AON) is enabled at 1.8 V.

A MPU  $t_{RSTTEMPO}$  (440  $\mu\text{s}$  typ.) delay is starts once the following voltages are reached:

- VDDIO voltage is above MPU  $V_{POR}$  threshold (1.67 V)
- VDDA1V8\_AON voltage is above MPU  $V_{POR\_ANA}$  threshold (1.67 V).

Once  $t_{RSTTEMPO}$  elapses, the MPU enters in system reset. After approximately 230 $\mu\text{s}$  of internal initialization, the MPU release internal  $nrst\_por$ , goes in system reset and the PWR\_ON signal goes high.

*Note:* NRST signal is kept low as the PMIC asserts the NRST signal until the end of the power-up sequence

b. RANK2 (1.5 ms): BUCK2 (VDDCORE) is enabled at 0.82 V. Once VDDCORE voltage rises above MPU  $V_{RDY\_VDDCORE}$  threshold (0.66 V), an MPU  $T_{delay\_VDDCORE}$  (400  $\mu\text{s}$  typ.) delay is started to allow VDDCORE voltage to reach minimum operating voltage. Once  $T_{delay\_VDDCORE}$  elapses, the MPU starts hardware initialization (such as starting the HSI oscillator, and so on). The PWR\_CPU\_ON signal goes high.

c. RANK3 (1.5 ms): The following regulators are enabled:

- BUCK1 (VDDCPU) is enabled at 0.80 V
- BUCK5 (1V8) is enabled at 1.8 V.

Once VDDCPU voltage is above MPU  $V_{RDY\_VDDCPU}$  threshold (0.66 V), a MPU  $T_{delay\_VDDCPU}$  (400  $\mu\text{s}$  typ.) delay is started to allow VDDCPU voltage to reach its minimum operating voltage. Once  $T_{delay\_VDDCPU}$  elapses, the MPU is ready to boot but it remains in reset until the PMIC releases the NRST signal.

d. RANK4 (1.5 ms): The following regulators are enabled a 3.3 V:

- BUCK7 (3V3)
- LDO2 (VDD\_eMMC).

*Note:* The STPMIC25D enables the LDO7 (VDD\_SDCARD) and the LDO8 (VDDIO\_SDCARD) in bypass mode enabling a boot over SD-Card UHS-I. See Section 4.1.8: SD-Card power domains ( $V_{DD\_SDCARD}$ ,  $V_{DDIO\_SDCARD}$ ).

e. RANK5 (1.5 ms): LDO4 (VDD3V3\_USB) is enabled.

f. Once RANK5 is ended, the PMIC releases the NRST signal, which releases the MPU NRST.

7. Once the NRST is released, the MPU enters in Run mode:

- a. The MPU releases the NRSTC1MS signal.
- b. The D1 CPU starts to execute the boot ROM: EADLY timer starts. Refer to EADLY timer for more information.
- c. Once the EADLY timer elapses, the boot ROM reads, verifies, and executes the bootloader from the external flash memory (eMMC).

8. The bootloader software performs all the initializations, then loads and executes the application software:
  - a. The software enable LDO5 (VPP\_DDR) at 2.5 V.
  - b. The software waits for 1 ms.
  - c. The software enables the following once the delay has elapsed:
    - REFDDR (V<sub>REF\_DDR</sub>)
    - LDO3 (V<sub>TT\_DDR</sub>) in sink-source mode
    - BUCK6 (V<sub>DD\_DDR</sub>) at 1.2 V
  - d. The software waits for 1 ms.
  - e. The MPU software initializes the DDR4 controller and DDR memory ICs.
  - f. The bootloader loads the application software into DDR4 and executes it. The kernel initializes.
  - g. The system is now running. The application software can enable the following regulators:
    - BUCK3 (VDDGPU) for the GPU
    - LDO7 (VDD\_SDCARD) and LDO8 (VDDIO\_SDCARD) for the SD-Card

Figure 6. Uncontrolled power down sequence

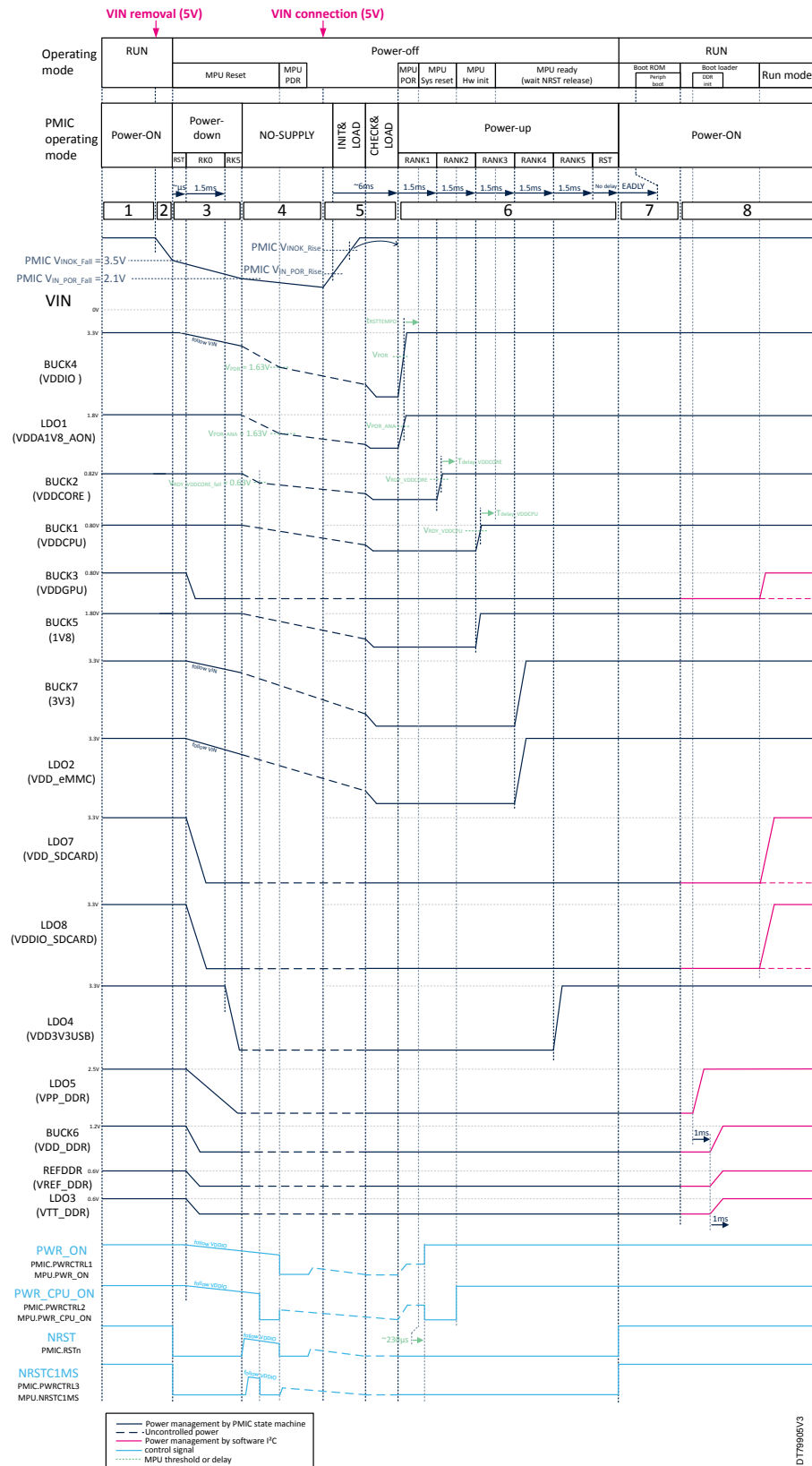

### 5.3 Low power mode management

The MPU supports several low-power modes to reduce power consumption as detailed in [4]. These are described in [Section 5.1: Operating modes](#). The modes supported by the application and their advantages/disadvantages are presented in the table below:

**Table 8. Low power mode supported by the application**

Power mode	Advantages	Disadvantages
LP-Stop1 mode	DDR termination (VTT) is shut down to reduce power consumption Very fast recovery from LP-Stop1 mode to Run mode	Low power consumption gain
LP-Stop2 mode	V <sub>DDCPU</sub> (D1) is OFF, so power consumption due to D1 current-leakage is saved. Lower power consumption than LP-Stop1 mode.	Longer exit recovery duration than LP-Stop1 mode.
LPLV-Stop1 mode	V <sub>DDCORE</sub> (D2) voltage is lowered. The D2 domain consumption is reduced.	Few EXTI wake-up sources are available to exit this mode. To exit this mode, more time is needed to restore the lowered supply to its nominal values.
LPLV-Stop2 mode	V <sub>DDCORE</sub> voltage is lowered and V <sub>DDCPU</sub> is shut down, the D2 domain consumption is reduced, and the D1 domain current leakage power consumption is saved.	Few EXTI wake-up sources are available to exit this mode. Longer exit recovery duration than LPLV-Stop1 mode.
Standby mode (DDR4 in self-refresh)	Very-low power consumption All MPU power domains are powered off except V <sub>DDIO</sub> and V <sub>DDA1V8_AON</sub> . DDR is maintained in self-refresh (suspend to RAM).	Few EXTI wake-up sources are available to exit this mode. Longer exit recovery duration than LPLV-Stop2 mode.
Standby mode (DDR4 OFF)	Lowest power consumption All MPU power domains are powered off except V <sub>DDIO</sub> and V <sub>DDA1V8_AON</sub> . DDR is powered off (suspend to flash)	Few EXTI wake-up sources are available to exit this mode. Longer exit recovery duration than Standby mode (DDR4 in self-refresh).

The MPU manages the low-power modes. As described in [PWRCTRL1](#), [PWRCTRL2](#), [PWRCTRL3](#), the power control signals are connected as defined in the table below.

**Table 9. Power control signal connection**

MPU output	PMIC input
PWR_ON	PWRCTRL1
PWR_CPU_ON	PWRCTRL2
NRSTC1MS	PWRCTRL3

These signals control the regulators directly from the MPU state machine. This is because, in low power mode, no software is running and the PMIC regulators cannot be controlled by any I<sup>2</sup>C command from software (see [Table 5](#)).

Before entering into low-power mode, the MPU software must prepare the PMIC to enter any of these power modes by setting:

- The PMIC xxxx\_MAIN\_CR registers with the Run mode behavior.
- The PMIC xxxx\_ALT\_CR registers with the targeted low-power mode behavior.

*Note:* The term "xxxx" corresponds to the targeted regulator.

The MPU software must also set some internal delays used in the following low power modes:

- LP-Stop1 mode
- LP-Stop2 mode
- LPLV-Stop1 mode
- LPLV-Stop2 mode
- Standby mode

The delays are described in the following section.

### 5.3.1 STM32MP25x internal timer for low power mode management

#### EADLY timer

The EADLY timer is a programmable timer used to produce a sufficient delay to ensure that external flash is available for the boot ROM to read the content (eMMC, FMC-NAND, OCTOSPI, SD-Card). This ensures that the boot ROM can reliably read the boot software from the flash boot memory. The EADLY timer duration is set to 5 ms by default after a system reset. It is recommended to keep this default value.

#### POPL timers

POPL timers are programmable timers used to force the MPU into low-power mode for a minimum duration. When entering in low-power mode, `PWR_ON` and/or `PWR_CPU_ON` signals go low for minimum POPL duration forcing peripheral power supply voltages to drop before low power mode exit. This is to ensure MPU peripherals to restart properly if a wake-up event occurs just after MPU enters low power mode. The MPU embeds two POPL timers:

- `POPL_D1` linked to the `PWR_CPU_ON` signal of the MPU. The `POPL_D1` defines the minimum duration of `PWR_CPU_ON` low pulse in the following low power mode:
  - Run2
  - LP-Stop2 mode
  - LPLV-Stop2 mode
  - Standby mode
- `POPL_D2` linked to the `PWR_ON` signal of the MPU. The `POPL_D2` defines the minimum duration of `PWR_ON` low pulse in `Standby mode`. This delay is not reset by: wake-up from `Standby mode`, nor MPU reset (NRST, watchdog).

The software sets the POPL timers prior to low power mode entry. Recommended values are proposed in the next sections depending on the low power mode needed.

#### PODH\_D2 timer

The `PODH_D2` is a programmable timer used to force the `PWR_ON` signal high while the `PWR_CPU_ON` goes low; when entering `Standby mode` to switch off `VDDCPU` before `VDDCORE`. The `PODH_D2` timer setting is not reset by wake-up from `Standby mode`, nor the MPU reset (NRST, watchdog).

The software must set the `PODH_D2` timer prior to entering `Standby mode`. Recommended values are proposed in [Section 5.3.4: Standby mode \(DDR4 in self-refresh\)](#) and [Section 5.3.5: Standby mode \(DDR4 OFF\)](#).

*Note:* The `PODH_D2` timer must override the `POPL_D1` timer.

#### LPLVDLY\_D2 timer

The `LPLVDLY_D2` is a programmable timer used at `LPLV-Stop1 mode` and `LPLV-Stop2 mode` exit to wait for the `VDDCORE` voltage to recover from the retention voltage (670 mV) to the nominal operating voltage (820 mV).

In `LPLV-Stop1 mode`, the `VDDCORE` is lowered to 670 mV, the `LPLVDLY_D2` is used to wait for `VDDCORE` to reach the operating supply level in Run mode (820 mV).

In `LPLV-Stop2 mode`, the `VDDCORE` is lowered to 670 mV and the `VDDCPU` is turned OFF, the `LPLVDLY_D2` is used to wait for `VDDCORE` to reach the operating supply level in Run mode (820 mV). Once this delay is elapsed, `VDDCPU` and the dedicated `PWRCTRL` (`PWR_CPU_ON`) starts to rise.

The LPLVDLY\_D2 timer must be set once by the software at 187  $\mu$ s ( $PWR\_D2CR[LPLVDLY\_D2]=0$ ). This value is defined as follows:

- PMIC internal 20  $\mu$ s delay between **PWRCTRL1** rise and  $V_{DDCORE}$  regulators state change
- A 150  $\mu$ s worst case delay of  $V_{DDCORE}$  voltage recovery from retention (670 mV) to nominal (820 mV).

So, in worst case, there is a 170  $\mu$ s total delay from **PWRCTRL1** signal rising to  $V_{DDCORE}$  recovered at 820 mV.

#### **Tdelay\_VDDCPU**

Tdelay\_VDDCPU is an internal and fixed delay (value defined in [5]). When  $V_{DDCPU}$  regulator is enabled and has reached the  $V_{RDY\_VDDCPU}$  threshold, the Tdelay\_VDDCPU is started to wait for  $V_{DDCPU}$  to reach the Run mode operating supply voltage level. Once Tdelay\_VDDCPU elapsed, the CPU1 (D1 domain) is released from reset and the CPU1 starts to run.

As long as  $V_{DDCPU}$  is below  $V_{RDY\_VDDCPU}$  the CPU remains in reset.

The Tdelay\_VDDCPU is used at power-up or when the system exits from **LP-Stop2 mode**, **LPLV-Stop2 mode**, or **Standby mode**.

#### **Tdelay\_VDDCORE**

Tdelay\_VDDCORE is an internal and fixed delay (value defined in [5]). When  $V_{DDCORE}$  regulator is enabled and has reached the  $V_{RDY\_VDDCORE}$  threshold, the Tdelay\_VDDCORE is started to wait for  $V_{DDCORE}$  to reach the Run mode operating supply voltage level. Once Tdelay\_VDDCORE elapsed, the core domain (D2 domain) is released from reset to run. As long as  $V_{DDCORE}$  is below  $V_{RDY\_VDDCORE}$  the core domain remains in reset.

The Tdelay\_VDDCORE is used at power-up or when the system exits from low-power **Standby mode**.

#### **PWRLP\_TEMPO timer**

The PWRLP\_TEMPO is a delay between the time when the system exits the **LP-Stop1 mode** and the moment when it is allowed to enable the PLLs. It is then able to provide a clock to CPU1 and CPU2, and enters in Run mode. This delay is linked to the D2 power domain ( $V_{DDCORE}$ ) and must be set in the **RCC\_PWRLPDLYCR[PWRLP\_DLY[21:0]]** register bitfield prior to entering low power mode.

The software must set the PWRLP\_DLY timer prior to entering low power mode. Recommended values are proposed in the next section.

#### **C1MSRD timer**

The CPU1 mass storage reset device (C1MSRD) is a programmable timer defining the minimum pulse duration of the NRSTC1MS signal when the system exits D1 **Standby mode**. Typically when the system exit from:

- **LP-Stop2 mode to Run1**
- **LPLV-Stop2 mode to Run1**
- **Run2 to Run1.**

This timer is also used in case of a D1 independent reset, typically to recover from a D1 crash to reboot the domain without rebooting the complete system. See [Section 4.1.7:  \$V\_{DD\\_eMMC}\$  power domain \(3.3 V\)](#) and [Section 4.1.8: SD-Card power domains \( \$V\_{DD\\_SDCARD}\$ ,  \$V\_{DDIO\\_SDCARD}\$ \) and \*\*PWRCTRL1\*\*, \*\*PWRCTRL2\*\*, \*\*PWRCTRL3\*\* section.](#)

The C1MSRD timer must be set by software at cold boot (boot loader). The recommended value for the C1MSRD is 2 ms as the PMIC has built in regulator discharge circuitry to drop regulator output voltage in less than 1.5 ms after the regulator has been turned off.

#### **MRD timer**

The MRD is a programmable timer defining the minimum pulse duration of the NRST system reset signal. This timer is useful when the supply is provided by a discrete power component, so it can be set to 0 with a PMIC.

### 5.3.2 LP-Stop1/LPLV-Stop1 mode

The LP-Stop1 and the LPLV-Stop1 low power modes produce similar regulator behaviors:

- In LPLV-Stop1, the DDR4 termination resistors supply ( $V_{TT\_DDR}$ ) is turned OFF and the  $V_{DDCORE}$  voltage is reduced
- In LP-Stop1, the DDR4 termination resistors supply ( $V_{TT\_DDR}$ ) is turned OFF and the  $V_{DDCORE}$  is kept at nominal value.

The LPLV-Stop1 mode has lower power consumption than the LP-Stop1 mode, but it requires additional delay to go from LPLV-Stop1 to Run1 mode to wait for  $V_{DDCORE}$  nominal voltage to stabilize.

The following section covers both LP-Stop1 and LPLV-Stop1 mode.

#### LP-Stop1 mode

The LP-Stop1 mode is described below and is shown in [Figure 7](#) based on to the implementation shown in [Figure 1](#).

1. The application is powered up and is running in Run1 operating mode; all  $PWR\_ON$  and  $PWR\_CPU\_ON$  are in high state. In this mode, the  $PWR\_LP$  signal is internally multiplexed with the  $PWR\_ON$  pin.
2. When the LP-Stop1 mode is requested, the software prepares to enter LP-Stop1 mode:
  - a. The MPU configures the PMIC as defined in [Table 10](#).
  - b. The MPU performs internal settings such as:
    - i. Set  $PWRLP\_TEMPO$  timer to 100  $\mu s$  (in  $RCC\_PWRLPDLYCR$  register).
    - ii. Stop all system clocks that are not required.
    - iii. Set the DDR4 to self-refresh.
  - c. The MPU may disable the GPU with the  $VDDGPU$  regulator
  - d. The MPU  $PWR\_CPU2CR[LPDS\_D2]$  and  $PWR\_CPU1CR[LPDS\_D1]$  bits are enabled. This allows the system to enter LP-Stop1 low power mode.
3. Once the system is in LP-Stop1:
  - a. The MPU  $PWR\_ON$  output is deasserted. The PMIC  $PWRCTRL1$  goes low
4. After 20  $\mu s$  internal PMIC delay, the PMIC regulators, which is connected to the  $PWR\_ON$  (linked to the  $PWRCTRL1$ ) takes the configuration set in the  $xxxx\_ALT\_CR$  registers (see [Table 10](#)): the  $V_{TT\_DDR}$  regulator turns OFF.
5. On a wake-up event, the MPU leaves the LP-Stop1 mode:
  - a. The MPU  $PWR\_ON$  output signal is asserted, driving the PMIC  $PWRCTRL1$  signal high.
  - b. After 20  $\mu s$  internal PMIC delay, the PMIC regulators, which is connected to the  $PWR\_ON$  takes the configuration set in the  $xxxx\_MAIN\_CR$  registers (see [Table 10](#)):
    - i. The  $V_{TT\_DDR}$  regulator turns ON
    - ii. The  $V_{TT\_DDR}$  voltage rises in 40  $\mu s$ .
  - c. Clocks are enabled and the software executes the  $PWRLP\_TEMPO$  timer (100  $\mu s$ ). This delay ensures that the  $V_{TT\_DDR}$  as reaches its nominal value before:
    - i. The system enters in Run1
    - ii. The software moves the DDR4 out of self-refresh mode.
6. Once the  $PWRLP\_TEMPO$  timer has elapsed, the application goes into Run1 mode. The software resumes LP-Stop1: DDR4 exit from self-refresh.

**Table 10. PMIC configuration for LP-Stop1 mode**

Regulator	PWRCTRLx affectionation	Register xxxx_MAIN_CR		Register xxxx_ALT_CR	
		Configuration	VOUT	Configuration	VOUT
BUCK1 (V <sub>DDCPU</sub> )	PWR_CPU_ON	ON HP	0.80	OFF	-
BUCK2 (V <sub>DDCORE</sub> )	PWR_ON	ON HP	0.82	ON HP	0.82
BUCK3 (V <sub>DDGPU</sub> )	-	ON/OFF HP	0.80	-	-
BUCK4 (V <sub>DDIO</sub> )	PWR_ON	ON HP	3.3	ON_HP	3.3
LDO1 (V <sub>DDA1V8_AON</sub> )	-	ON	N/A	-	N/A
BUCK5 (1V8)	PWR_ON	ON HP	1.8	ON HP	1.8
BUCK6 (V <sub>DD_DDR</sub> )	PWR_ON	ON HP	1.2	ON HP	1.2
BUCK7 (3V3)	PWR_ON	ON HP	3.3	ON HP	3.3
V <sub>REF_DDR</sub>	PWR_ON	ON	N/A	ON	N/A
LDO5 (V <sub>PP_DDR</sub> )	PWR_ON	ON	2.5	ON	2.5
LDO2 (V <sub>DD_eMMC</sub> )	NRSTC1MS <sup>(1)</sup>	ON/OFF	3.3	-	-
LDO3 (V <sub>TT_DDR</sub> )	PWR_ON	SINK SOURCE	-	OFF	-
LDO4 (V <sub>DD3V3_USB</sub> )	-	ON/OFF	N/A	-	N/A

1. The LDO2 is controlled from PWRCTRL3 in reset mode (PMIC PWRCTRL\_RST bit set for LDO2)

**Note:** If SD-Card (UHS-I) is the boot flash memory, use the STPMIC25D (see Section 4.1.8: SD-Card power domains (V<sub>DD\_SDCARD</sub>, V<sub>DDIO\_SDCARD</sub>). In that case LDO7 (V<sub>DD\_SDCARD</sub>) and LDO8 (V<sub>DDIO\_SDCARD</sub>) must be assigned to NRSTC1MS (PWRCTRL3) as the LDO2 on the Table 10 by setting their respective PWRCTRL\_RST bit.

Figure 7. LP-Stop1 sequence

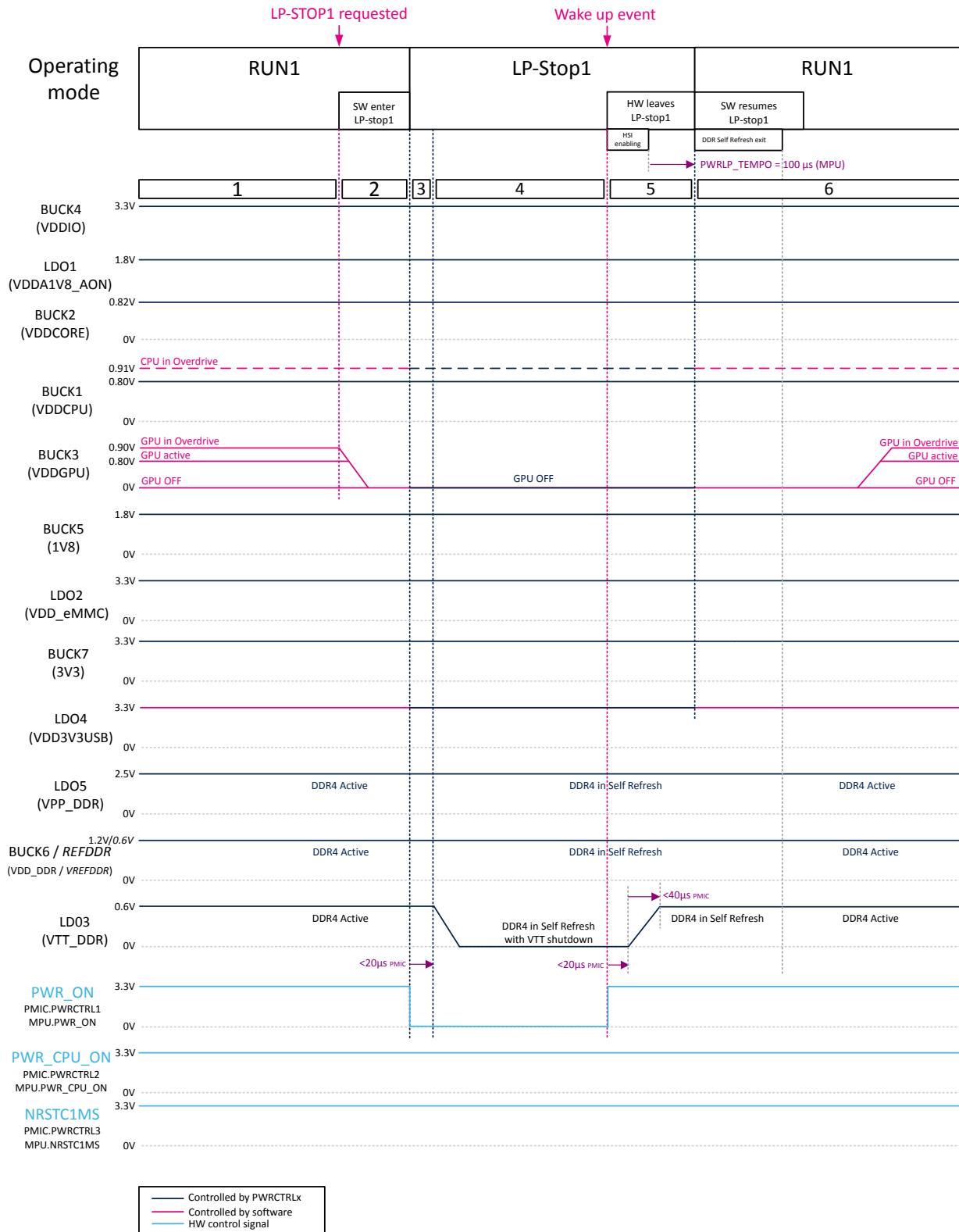

### LPLV-Stop1 mode

The LPLV-Stop1 mode is described below and is illustrated in the [Figure 8](#) based on to the implementation shown in [Figure 1](#).

1. The application is powered up and is operating in Run1 mode, all `PWR_ON` and `PWR_CPU_ON` are in high state. In this mode, the `PWR_LP` signal is internally multiplexed with the `PWR_ON` pin.
2. When the LPLV-Stop1 mode is requested, the software prepares to enter LPLV-Stop1 mode:
  - a. The MPU configures the PMIC as defined in [Table 11](#).
  - b. If CPU1 is in overdrive mode, the software sets CPU1 to nominal mode and sets `VDDCPU` to nominal voltage (from 0.91 V to 0.8 V).
  - c. The MPU configures the internal settings such as:
    - i. Disable the `PWRLP_TEMPO` timer (set `RCC_PWRLPDLYCR[PWRLP_DLY[21:0]]=0`).
    - ii. Set `LPLVDLY_D2` timer to 187  $\mu$ s. This is done by setting `PWR_D2CR[LPLVDLY_D2[2:0]]=0`.
    - iii. Stop all system clocks that are not required.
    - iv. Set the DDR into self-refresh.
  - d. The MPU may disable the GPU with the `VDDGPU` regulator.
  - e. The MPU `PWR_CPU2CR[LPDS_D2]` and `PWR_CPU2CR[LVDS_D2]` bit are enabled. This allows the system to enter LPLV-Stop1 low power mode.
3. Once the system is in LPLV-Stop1:
  - a. The MPU `PWR_ON` output is deasserted, and the PMIC `PWRCTRL1` goes low.
4. After 20  $\mu$ s internal PMIC delay, the PMIC regulators assigned to `PWR_ON` (linked to the `PWRCTRL1`) takes on the configuration set in the `xxxx_ALT_CR` registers, which is defined in [Table 11](#):
  - a. `VTT_DDR` regulator is turned OFF.
  - b. `VDDCORE` regulator output decreases to retention voltage (from 820 mV to 670 mV).
5. On a wake-up event, the MPU leaves the LPLV-Stop1 mode:
  - a. The MPU `PWR_ON` output signal is asserted, driving the PMIC `PWRCTRL1` signal high and the MPU executes the `LPLVDLY_D2` timer to allow the `VDDCORE` to switch from retention voltage (670 mV) to the minimum operating voltage (765 mV).
  - b. After 20  $\mu$ s internal PMIC delay, the PMIC regulators assigned to `PWR_ON` take on the configuration set in the `xxxx_MAIN_CR` registers (see [Table 11](#)):
    - i. The `VTT_DDR` regulator is turned ON (`VTT_DDR` voltage rise in 40  $\mu$ s)
    - ii. The `VDDCORE` regulator switches from retention voltage (670 mV) to minimum operating voltage (765 mV) in 95  $\mu$ s. Then it converges to nominal voltage (820 mV).
  - c. Once the `LPLVDLY_D2` timer elapsed, clocks are enabled.
  - d. Once clocks are stable, the MPU goes immediately in Run1 mode (as `PWRLP_TEMPO` timer is bypassed).
6. The software resumes from LPLV-Stop1, exits DDR4 from self-refresh.

**Table 11. PMIC configuration for LPLV-Stop1 mode**

Regulator	PWRCTRLx assignment	Register xxxx_MAIN_CR		Register xxxx_ALT_CR	
		Configuration	VOUT	Configuration	VOUT
BUCK1 (V <sub>DDCPU</sub> )	PWR_CPU_ON	ON HP	0.80	OFF	-
BUCK2 (V <sub>DDCORE</sub> )	PWR_ON	ON HP	0.82	ON HP	0.67
BUCK3 (V <sub>DDGPU</sub> )	-	ON/OFF HP	0.80	-	-
BUCK4 (V <sub>DDIO</sub> )	PWR_ON	ON HP	3.3	ON_HP	3.3
LDO1 (V <sub>DDA1V8_AON</sub> )	-	ON	N/A	-	N/A
BUCK5 (1V8)	PWR_ON	ON HP	1.8	ON HP	1.8
BUCK6 (V <sub>DD_DDR</sub> )	PWR_ON	ON HP	1.2	ON HP	1.2
BUCK7 (3V3)	PWR_ON	ON HP	3.3	ON HP	3.3
V <sub>REF_DDR</sub>	PWR_ON	ON	N/A	ON	N/A
LDO5 (V <sub>PP_DDR</sub> )	PWR_ON	ON	2.5	ON	2.5
LDO2 (V <sub>DD_eMMC</sub> )	NRSTC1MS <sup>(1)</sup>	ON/OFF	3.3	-	-
LDO3 (V <sub>TT_DDR</sub> )	PWR_ON	SINK SOURCE	-	OFF	-
LDO4 (V <sub>DD3V3_USB</sub> )	-	ON/OFF	N/A	-	N/A

1. The LDO2 is controlled from PWRCTRL3 in reset mode (PMIC PWRCTRL\_RST bit set for LDO2)

**Note:** If SD-Card (UHS-I) is the boot flash memory, use the STPMIC25D (see Section 4.1.8: SD-Card power domains (V<sub>DD\_SDCARD</sub>, V<sub>DDIO\_SDCARD</sub>). In that case LDO7 (V<sub>DD\_SDCARD</sub>) and LDO8 (V<sub>DDIO\_SDCARD</sub>) must be assigned to NRSTC1MS (PWRCTRL3) as the LDO2 on the Table 11 by setting their respective PWRCTRL\_RST bit.

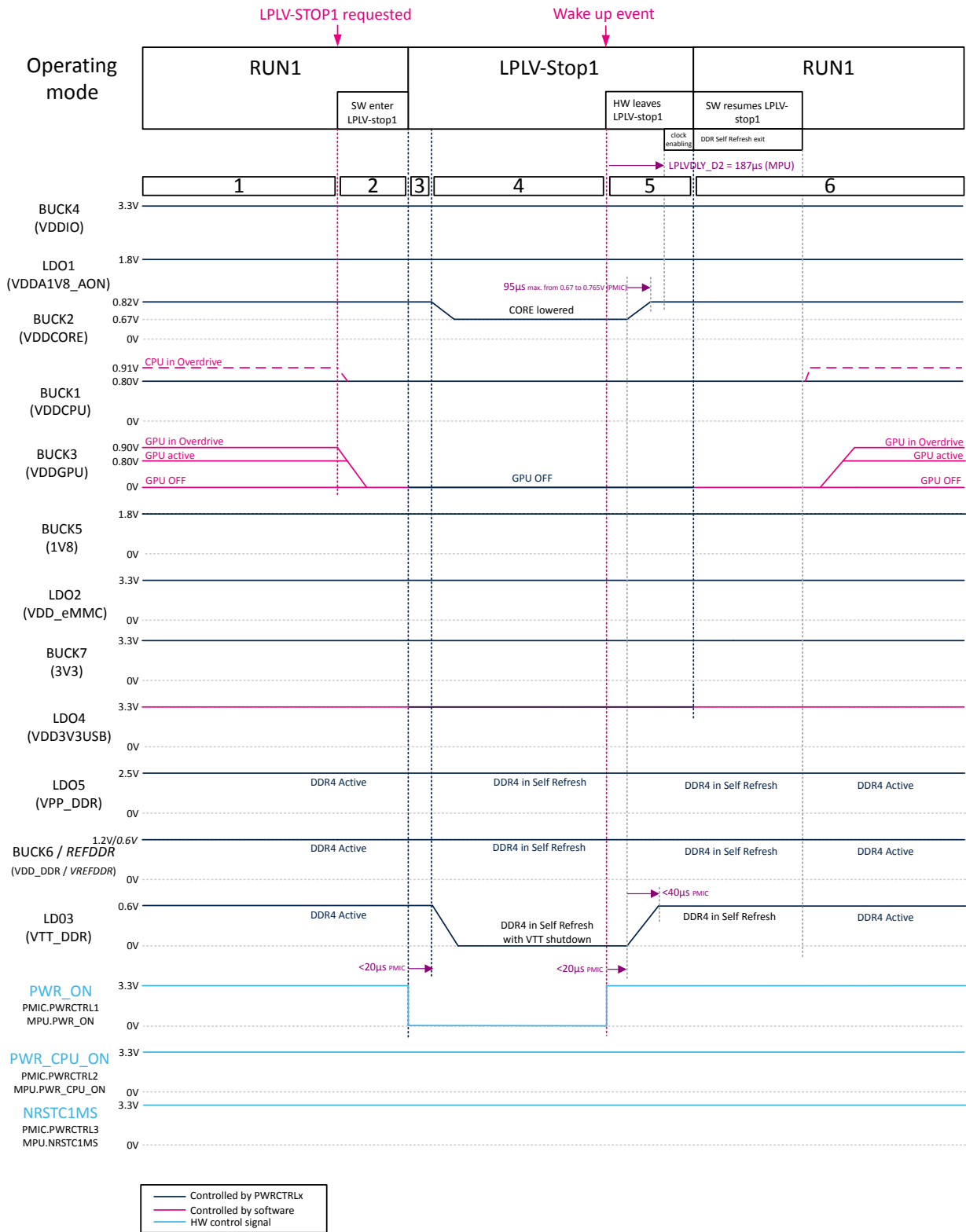
**Figure 8. LPLV-Stop1 sequence**

### 5.3.3 LP-Stop2/LPLV-Stop2 mode

The regulator behavior of both LP-Stop2 mode and LPLV-Stop2 low power modes are similar:

- In LPLV-Stop2, the  $V_{DDCPU}$  is shut down and the  $V_{DDCORE}$  voltage is reduced.
- In LP-Stop2, the  $V_{DDCPU}$  is shut down and the  $V_{DDCORE}$  is kept at nominal value.

The LPLV-Stop2 has lower power consumption than the LP-Stop2, but it requires additional time for the device to resume Run1 mode from LPLV-Stop2. This is to allow for  $V_{DDCORE}$  to reach its nominal stabilized voltage.

#### LP-Stop2 mode

The LP-Stop2 mode is described below and is shown in the [Figure 9](#) based on to the implementation shown in [Figure 1](#).

1. The application is powered up and operating in Run1 mode; all `PWR_ON` and `PWR_CPU_ON` are in high state. In this mode, the `PWR_LP` signal is internally multiplexed with the `PWR_ON` pin.
2. When LP-Stop2 mode is requested, the software prepares to enter LP-Stop2 mode:
  - a. The MPU configures the PMIC as described in [Table 12](#).
  - b. If CPU1 is in overdrive mode, the software sets CPU1 to nominal mode and sets  $V_{DDCPU}$  to nominal voltage (from 0.91 V to 0.8 V).
  - c. The MPU configures the internal settings such as:
    - i. Set `PWR_D1CR[POPL_D1]` = 3 ms timer, to define a minimum pulse duration of `PWR_CPU_ON`. This ensures the full discharge of the  $V_{DDCPU}$  voltage before restarting.
    - ii. Disable the `PWRLP_TEMPO` timer (set `RCC_PWRLPDLYCR[PWRLP_DLY[21:0]]`=0).
    - iii. Stop all system clocks that are not required.
    - iv. Set the DDR to self-refresh.
  - d. The MPU may disable the GPU with the  $V_{DDGPU}$  regulator
  - e. The `PWR_CPU2CR[LPDS_D2]` bit is enabled. This allows the system to enter LP-Stop2 low power mode.
  - f. The `PWR_CPU1CR[PDDS_D1]` bit is enabled. This allows the D1 domain to enter in DStandby, with  $V_{DDCPU}$  switched OFF.
3. Once the system is in LP-Stop2:
  - a. The MPU `PWR_ON` is deasserted and the PMIC `PWRCTRL1` goes low.
  - b. The MPU `PWR_CPU_ON` is deasserted and the PMIC `PWRCTRL2` goes low.
  - c. The `NRSTC1MS` signal follows the `PWR_CPU_ON` signal (PMIC `PWRCTRL3` goes low).
  - d. The MPU `POPL_D1` timer is started to keep the D1 domain powered off until the `POPL_D1` timer has elapsed. The wake-up event is shifted until `POPL_D1` has elapsed.
4. After 20  $\mu$ s internal PMIC delay, the PMIC regulators assigned to `PWR_ON` (linked to the `PWRCTRL1`) and `PWR_CPU_ON` (linked to the `PWRCTRL2`) and `NRSTC1MS` (linked to the `PWRCTRL3`) takes the configuration set in the `xxxx_ALT_CR` registers (see [Table 12](#)):
  - a.  $V_{TT\_DDR}$  regulator is turned OFF
  - b.  $V_{DDCPU}$  regulator is turned OFF
  - c.  $V_{DD\_eMMC}$  regulator is turned OFF.

5. On a wake-up event, the MPU leaves the LP-Stop2 mode:
  - a. The MPU `PWR_ON` signal is asserted (PMIC `PWRCTRL1` goes high) and the clock are enabled.
  - b. After a 20  $\mu$ s internal PMIC delay, the PMIC regulators assigned to the `PWR_ON` takes the configuration set in the `xxxx_MAIN_CR` registers (see Table 12):
    - i. The `VTT_DDR` regulator is turned ON
    - ii. The `VTT_DDR` voltage rises in 40  $\mu$ s
  - c. Once the clocks are stable, the MPU `PWR_CPU_ON` is immediately asserted as the `PWRLP_TEMPO` is bypassed. The PMIC `PWRCTRL2` follows the `PWR_CPU_ON`.
  - d. The `NRSTC1MS` signal follows `PWR_CPU_ON` and the PMIC `PWRCTRL3` goes high.
  - e. Following a further 20  $\mu$ s internal PMIC delay, the PMIC regulators assigned to the `PWR_CPU_ON` and `NRSTC1MS` take on the configuration set in the `xxxx_MAIN_CR` registers (see Table 12):
    - `VDDCPU` regulator is turned ON
    - `VDD_eMMC` regulator is turned ON.
  - f. Once the `VDDCPU` voltage reaches the `VRDY_VDDCPU` threshold, the internal `Tdelay_VDDCPU` is started to wait for `VDDCPU` to reach its minimum operating voltage.
6. Once the `Tdelay_VDDCPU` has elapsed, the CPU1 releases the clock domain to enter in `Run1` mode and the system resumes from LP-Stop2. In this case, the Cortex<sup>®</sup>-A35 (CPU1) is set as master and the Cortex<sup>®</sup>-M33 (CPU2) follows the Cortex<sup>®</sup>-A35:
  - a. A CPU1 reset occurs, then CPU1 reboots from the boot ROM, which jumps in software present in `SYSRAM`.
  - b. DDR exits from self-refresh by software running in `SYSRAM` (secure monitor).

*Note:* The system enters in `Run1` mode only once the CPU1 clocks is released. The Cortex<sup>®</sup>-M33 is running once the DDR4 exits from self-refresh.

**Table 12. PMIC configuration for LP-Stop2**

Regulator	PWRCTRLx assignment	Register xxxx_MAIN_CR		Register xxxx_ALT_CR	
		Configuration	VOUT	Configuration	VOUT
BUCK1 (V <sub>DDCPU</sub> )	PWR_CPU_ON	ON HP	0.8	OFF	-
BUCK2 (V <sub>DDCORE</sub> )	PWR_ON	ON HP	0.82	ON HP	0.82
BUCK3 (V <sub>DDGPU</sub> )	-	ON/OFF HP	0.8	N/A	-
BUCK4 (V <sub>DDIO</sub> )	PWR_ON	ON HP	3.3	ON HP	3.3
LDO1 (V <sub>DDA1V8_AON</sub> )	-	ON	N/A	-	N/A
BUCK5 (1V8)	PWR_ON	ON HP	1.8	ON HP	1.8
BUCK6 (V <sub>DD_DDR</sub> )	PWR_ON	ON HP	1.2	ON HP	1.2
BUCK7 (3V3)	PWR_ON	ON HP	3.3	ON HP	3.3
V <sub>REF_DDR</sub>	PWR_ON	ON	N/A	ON	N/A
LDO5 (V <sub>PP_DDR</sub> )	PWR_ON	ON	2.5	ON	2.5
LDO2 (V <sub>DD_eMMC</sub> )	NRSTC1MS <sup>(1)</sup>	ON	3.3	-	-
LDO3 (V <sub>TT_DDR</sub> )	PWR_ON	SINK SOURCE	-	OFF	-
LDO4 (V <sub>DD3V3_USB</sub> )	-	ON/OFF	N/A	-	N/A

1. The LDO2 is controlled from PWRCTRL3 in reset mode (PMIC PWRCTRL\_RST bit set for LDO2)

**Note:** If SD-Card (UHS-I) is the boot flash memory, use the STPMIC25D (see Section 4.1.8: SD-Card power domains (V<sub>DD\_SDCARD</sub>, V<sub>DDIO\_SDCARD</sub>). In that case LDO7 (V<sub>DD\_SDCARD</sub>) and LDO8 (V<sub>DDIO\_SDCARD</sub>) must be assigned to NRSTC1MS (PWRCTRL3) as the LDO2 on the Table 12 by setting their respective PWRCTRL\_RST bit.

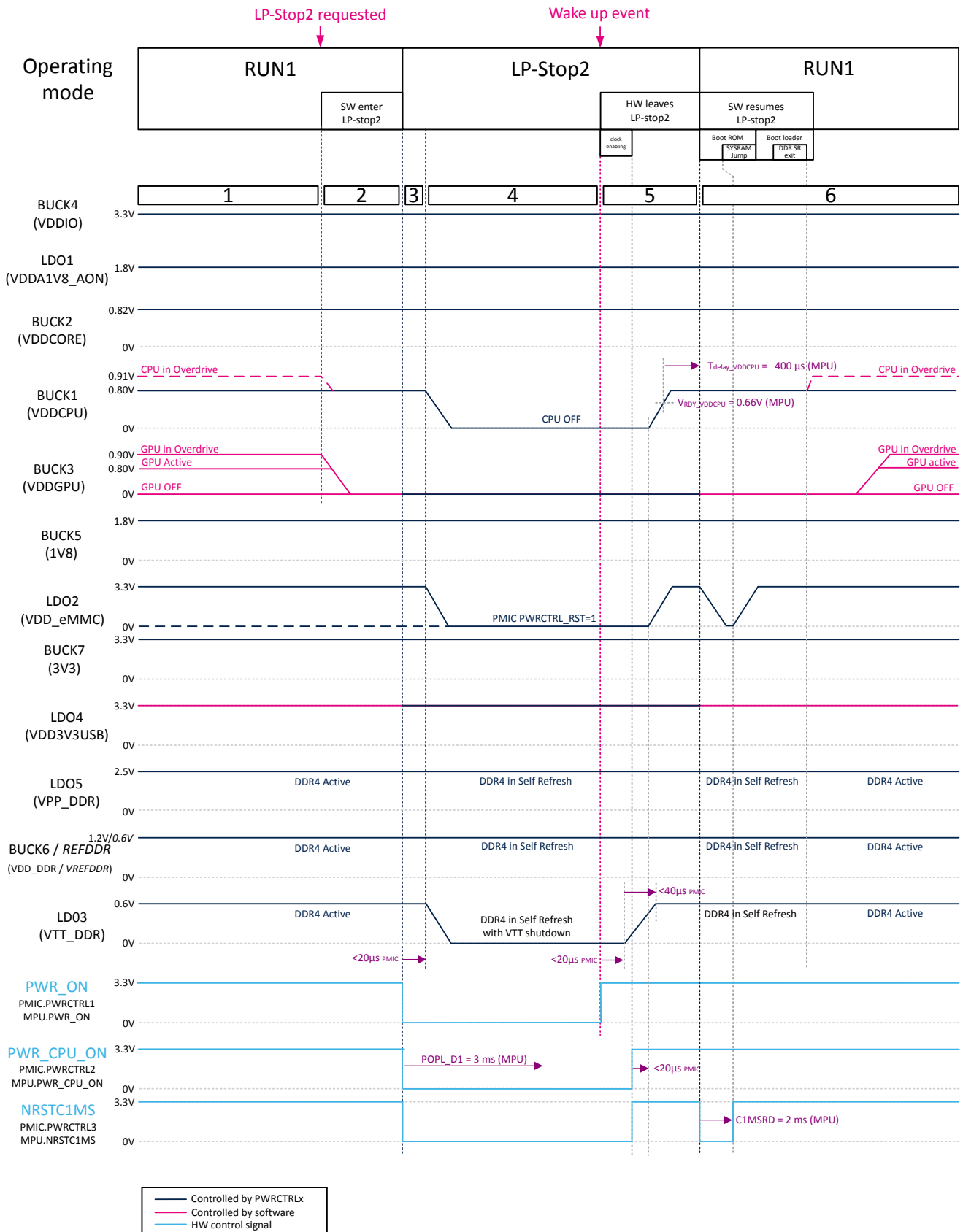
**Figure 9. LP-Stop2 sequence**

### LPLV-Stop2 mode

This section focuses on LPLV-Stop2 mode. The LPLV-Stop2 mode is shown in the [Figure 10](#) based on to the implementation shown in [Figure 1](#).

1. The application is powered up and operates in Run1 mode; all `PWR_ON` and `PWR_CPU_ON` are in high state. In this mode, the `PWR_LP` signal is internally multiplexed with the `PWR_ON` pin.
2. When LPLV-Stop2 mode is requested, the software prepares to enter LPLV-Stop2 mode:
  - a. The MPU configures the PMIC as described in [Table 13](#).
  - b. If CPU1 is in overdrive mode, the software sets CPU1 to nominal mode and sets `VDDCPU` to nominal voltage (from 0.91 V to 0.8 V).
  - c. The MPU performs internal settings such as:
    - i. Set `PWR_D1CR[POPL_D1]` = 3 ms timer, to define a minimum pulse duration of `PWR_CPU_ON` ensuring full discharge of the `VDDCPU` voltage before restarting.
    - ii. Set the `LPLVDLY_D2` timer to 187  $\mu$ s (set `PWR_D2CR[LPLVDLY_D2[2:0]]`=0).
    - iii. Disable `PWRLP_TEMPO` timer (set `RCC_PWRLPDLYCR[PWRLP_DLY]`=0).
    - iv. Stop all system clocks that are not required.
    - v. Set the DDR to self-refresh.
  - d. The MPU may disable the GPU with the `VDDGPU` regulator.
  - e. The `PWR_CPU2CR[LPDS_D2]` and `PWR_CPU2CR[LVDS_D2]` bits are enabled. This allows the system to enter into the LPLV-Stop2 low power mode.
  - f. The `PWR_CPU1CR[PDDS_D1]` bit is enabled. This allows the D1 domain to enter in DStandby (`VDDCPU` switched OFF).
3. Once the system is in LPLV-Stop2:
  - a. The MPU `PWR_ON` is deasserted, and the PMIC `PWRCTRL1` signal goes low.
  - b. The MPU `PWR_CPU_ON` is deasserted, and the PMIC `PWRCTRL2` signal goes low.
  - c. The `NRSTC1MS` signal follows the `PWR_CPU_ON` signal, and the PMIC `PWRCTRL3` goes low.
  - d. The `POPL_D1` delay is started to keep the D1 domain powered off until the `POPL_D1` timer has elapsed. This means, the wake-up event is shifted until `POPL_D1` has elapsed.
4. After 20  $\mu$ s internal PMIC delay, the PMIC regulators assigned to `PWR_ON` (linked to the `PWRCTRL1`) and `PWR_CPU_ON` (linked to the `PWRCTRL2`) and `NRSTC1MS` (linked to the `PWRCTRL3`) takes the configuration set in the `xxxx_ALT_CR` registers (see [Table 13](#)):
  - a. `VTT_DDR` regulator is turned OFF.
  - b. `VDDCORE` regulator output decreases to retention voltage (from 820 mV to 670 mV).
  - c. `VDDCPU` regulator is turned OFF.
  - d. `VDD_eMMC` regulator is turned OFF.
5. On a wake-up event, the MPU leaves the LPLV-Stop2:
  - a. The MPU `PWR_ON` output signal is asserted driving the PMIC `PWRCTRL1` signal high and the MPU executes the `LPLVDLY_D2` timer to wait for the `VDDCORE` to switch from retention voltage (670 mV) to minimum operating voltage (765 mV).
  - b. After a 20  $\mu$ s internal PMIC delay, the PMIC regulators assigned to the `PWR_ON` takes the configuration set in the `xxxx_MAIN_CR` registers (see [Table 13](#)):
    - i. The `VTT_DDR` regulator is turned ON (`VTT_DDR` voltage rise in 40  $\mu$ s)
    - ii. The `VDDCORE` regulator switches from retention voltage (670 mV) to the minimum operating voltage (765 mV) in 95  $\mu$ s maximum. Then, it converges to nominal voltage (820 mV).
  - c. Once the `LPLVDLY_D2` timer elapsed, clocks are enabled.
  - d. After a further 20  $\mu$ s internal PMIC delay, the PMIC regulators assigned to the `PWR_CPU_ON` and `NRSTC1MS` take on the configuration set in the `xxxx_MAIN_CR` registers (see [Table 13](#)):
    - i. `VDD_eMMC` regulator is turned ON.
    - ii. `VDDCPU` regulator is turned ON.
  - e. Once the `VDDCPU` voltage reaches the `VRDY_VDDCPU` threshold, the `Tdelay_VDDCPU` delay is triggered to ensure `VDDCPU` reaches its minimum operating voltage.

6. Once  $T_{delay\_V_{DDCPU}}$  is elapsed, CPU1 releases the clock domain to enter Run1 mode, the system resumes from LPLV-Stop2. In this case, the Cortex<sup>®</sup>-A35 (CPU1) is set as master and the Cortex<sup>®</sup>-M33 (CPU2) follows the Cortex<sup>®</sup>-A35:
  - a. A CPU1 reset occurs, then CPU1 reboots from the boot ROM, which jumps in software present in SYSRAM.
  - b. DDR exits from self-refresh by software running in SYSRAM (secure monitor).

**Note:** *The system enters in Run1 once the CPU1 clocks are released. The Cortex<sup>®</sup>-M33 is running once the DDR4 exits from self-refresh.*

**Table 13. PMIC configuration for LPLV-Stop2**

Regulator	PWRCTRLx assignment	Register xxxx_MAIN_CR		Register xxxx_ALT_CR	
		Configuration	VOUT	Configuration	VOUT
BUCK1 (V <sub>DDCPU</sub> )	PWR_CPU_ON	ON HP	0.8	OFF	-
BUCK2 (V <sub>DDCORE</sub> )	PWR_ON	ON HP	0.82	ON HP	0.67
BUCK3 (V <sub>DDGPU</sub> )	-	ON/OFF HP	0.8	-	-
BUCK4 (V <sub>DDIO</sub> )	PWR_ON	ON HP	3.3	ON HP	3.3
LDO1 (V <sub>DDA1V8_AON</sub> )	-	ON	N/A	-	N/A
BUCK5 (1V8)	PWR_ON	ON HP	1.8	ON HP	1.8
BUCK6 (V <sub>DD_DDR</sub> )	PWR_ON	ON HP	1.2	ON HP	1.2
BUCK7 (3V3)	PWR_ON	ON HP	3.3	ON HP	3.3
V <sub>REF_DDR</sub>	PWR_ON	ON	N/A	ON	N/A
LDO5 (V <sub>PP_DDR</sub> )	PWR_ON	ON	2.5	ON	2.5
LDO2 (V <sub>DD_eMMC</sub> )	NRSTC1MS <sup>(1)</sup>	ON/OFF	3.3	-	-
LDO3 (V <sub>TT_DDR</sub> )	PWR_ON	SINK SOURCE	-	OFF	-
LDO4 (V <sub>DD3V3_USB</sub> )	-	ON/OFF	N/A	-	N/A

1. *The LDO2 is controlled from PWRCTRL3 in reset mode (PMIC PWRCTRL\_RST bit set for LDO2)*

**Note:** *If SD-Card (UHS-I) is the boot flash memory, use the STPMIC25D (see Section 4.1.8: SD-Card power domains (V<sub>DD\_SDCARD</sub>, V<sub>DDIO\_SDCARD</sub>). In that case LDO7 (V<sub>DD\_SDCARD</sub>) and LDO8 (V<sub>DDIO\_SDCARD</sub>) must be assigned to NRSTC1MS (PWRCTRL3) as the LDO2 on the Table 13 by setting their respective PWRCTRL\_RST bit.*

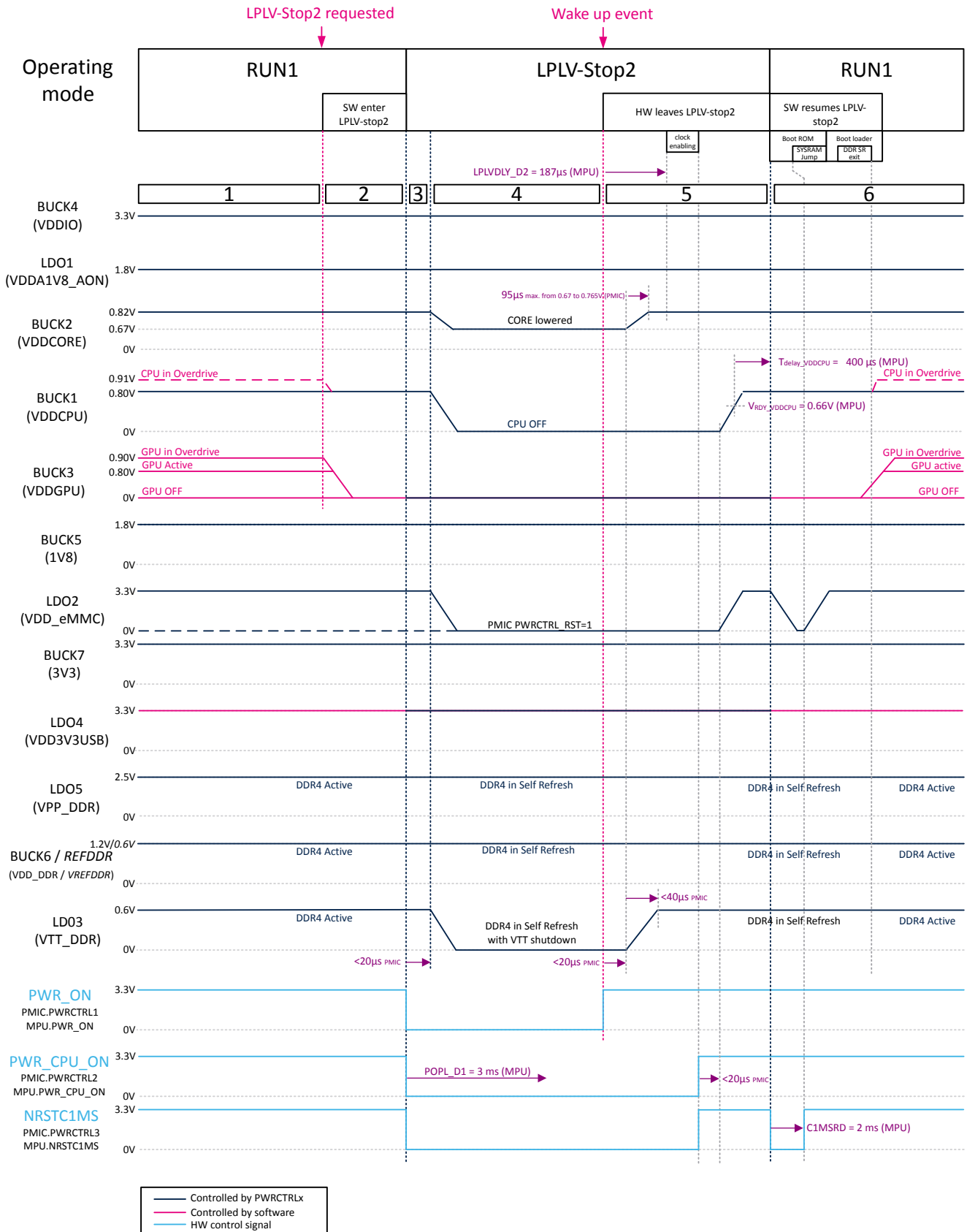
**Figure 10. LPLV-Stop2 sequence**

**Note:** *If the wake-up event is generated from one of the WKUP pins or EXTI2, the PWR\_CPU\_ON and the PWR\_ON rise at the same time: the V<sub>DDCORE</sub> recovers at the same time as the V<sub>DDCPU</sub> rise. So, the LPLVDLY\_D2 timer run in parallel with the T<sub>delay\_VDDCPU</sub> once V<sub>DDCPU</sub> is higher than V<sub>RDY\_VDDCPU</sub>.*

### 5.3.4 Standby mode (DDR4 in self-refresh)

The **Standby mode** is used when a very-low power consumption is required. In this mode, the MPU PWRCTRLx signals are pulled low. Most of the PMIC regulators are switched off. The content of MPU registers and memories are lost except for the backup and retentions domains (V<sub>DDIO</sub> and V<sub>DDA1V8\_AON</sub> are kept enabled). The DDR4 is set in self-refresh (V<sub>DD\_DDR</sub>, V<sub>REF\_DDR</sub> and V<sub>PP\_DDR</sub> are kept enabled) to maintain the system in “suspend to RAM state.”

This section focuses on **Standby mode** with DDR4 in self-refresh. This mode is shown in [Figure 11](#) based on the implementation shown in [Figure 1](#).

1. The application is powered up and operates in **Run1** mode. All PWR\_ON and PWR\_CPU\_ON are in high state.
2. When the **Standby mode** is requested, the software prepares to enter **Standby mode**:
  - a. The MPU configures the PMIC as described in [Table 14](#).
  - b. If CPU1 is in overdrive mode, the software sets CPU1 to nominal mode and sets V<sub>DDCPU</sub> to nominal voltage (from 0.91 V to 0.8 V).
  - c. The MPU disables the GPU then turns OFF the V<sub>DDGPU</sub> regulator
  - d. The MPU disables the USB then turns OFF the V<sub>DD3V3\_USB</sub> regulator
  - e. The MPU performs internal settings such as:
    - i. Set the PWR\_D1CR[POPL\_D1] = 3 ms timer, to define a minimum pulse duration of PWR\_CPU\_ON ensuring full discharge of the V<sub>DDCPU</sub> voltage before restarting.
    - ii. Set the PWR\_D2CR[PODH\_D2] = 1 ms timer, to turn off V<sub>DDCPU</sub> before V<sub>DDCORE</sub>.
    - iii. Set the PWR\_D2CR[POPL\_D2] = 2 ms, to define a minimum pulse duration of PWR\_ON ensuring V<sub>DDCORE</sub> voltage is fully discharged before restarting.
    - iv. Stop all system clocks that are not required.
    - v. Set the DDR to self-refresh.
  - f. The PWR\_CPU2CR[PDDS\_D2] bit is enabled. **Standby mode** is allowed when CPU2 goes OFF.
  - g. The PWR\_CPU1CR[PDDS\_D1] and PWR\_CPU1CR[PDDS\_D2] bit are enabled. This allows the D1 domain to enter in DStandby (V<sub>DDCPU</sub> switched OFF) and the **Standby mode** is allowed when CPU1 goes OFF.
3. Once the system is in **Standby mode**:
  - a. The MPU PWR\_CPU\_ON is deasserted. The PMIC PWRCTRL2 goes low.
  - b. The NRSTC1MS signal follows the PWR\_CPU\_ON signal (PMIC PWRCTRL3 goes low)
  - c. The POPL\_D1 timer is started to keep the D1 domain powered off until the POPL\_D1 timer has elapsed. The wake-up event is shifted until POPL\_D1 has elapsed.
  - d. The PODH\_D2 timer is started to keep V<sub>DDCORE</sub> enabled (PWR\_ON keeps high) waiting for the V<sub>DDCPU</sub> voltage to be powered off before V<sub>DDCORE</sub>.
4. After a 20 μs internal PMIC delay, the PMIC regulators assigned to PWR\_CPU\_ON (linked to PWRCTRL2) and NRSTC1MS (linked to PWRCTRL3) take on the configuration set in the xxxx\_ALT\_CR registers (see [Table 14](#)):
  - a. V<sub>DDCPU</sub> regulator is turned OFF
  - b. V<sub>DD\_eMMC</sub> regulator is turned OFF
5. Once PODH\_D2 timer has elapsed:
  - a. The MPU PWR\_ON is deasserted. The PMIC PWRCTRL1 signal goes low.
  - b. The POPL\_D2 timer is started to keep the D2 domain powered off until POPL\_D2 has elapsed. The wakeup event is shifted until POPL\_D2 has elapsed.

6. After a 20  $\mu$ s internal PMIC delay has elapsed, the PMIC regulators assigned to **PWR\_ON** (linked to **PWRCTRL1**) take on the configuration set in the **xxxx\_ALT\_CR** registers (see [Table 14](#)):
  - a. **VDDCORE** regulator is turned OFF
  - b. **1V8** regulator is turned OFF
  - c. **3V3** regulator is turned OFF
  - d. **VTT\_DDR** regulator is turned OFF
7. On a wake-up event, the MPU leaves the **Standby mode**:
  - a. The MPU **PWR\_ON** signal is asserted (PMIC **PWRCTRL1** goes high).
  - b. After a 20  $\mu$ s internal PMIC delay, the PMIC regulators assigned to **PWR\_ON** takes on the configuration set in the **xxxx\_MAIN\_CR** registers (see [Table 14](#)):
    - i. **VTT\_DDR** regulator is turned ON.
    - ii. **3V3** regulator is turned ON.
    - iii. **1V8** regulator is turned ON.
    - iv. **VDDCORE** regulator is turned ON.
  - c. Once the **VDDCORE** voltage reaches the **V<sub>RDY\_VDDCORE</sub>** threshold, the **T<sub>delay\_VDDCORE</sub>** internal delay is started. This ensures **VDDCORE** reaches its minimum operating voltage value.
  - d. Once the **T<sub>delay\_VDDCORE</sub>** delay has elapsed, the clocks are enabled and the MPU **PWR\_CPU\_ON** is asserted.
  - e. The **NRSTC1MS** signal follows **PWR\_CPU\_ON**.
  - f. After 20  $\mu$ s internal PMIC delay, the PMIC regulators assigned to **PWR\_CPU\_ON** and **NRSTC1MS** take the configuration set in the **xxxx\_MAIN\_CR** registers (see [Table 14](#)):
    - i. **VDD\_eMMC** regulator is turned ON.
    - ii. **VDDCPU** is turned ON.
  - g. Once the **VDDCPU** voltage reaches the **V<sub>RDY\_VDDCPU</sub>** threshold, the **T<sub>delay\_VDDCPU</sub>** internal delay is started. This is to ensure that **VDDCPU** reaches its minimum operating voltage value.
8. Once **T<sub>delay\_VDDCPU</sub>** has elapsed, CPU1 releases the clock domain to enter in **Run1** mode and the system resumes from the **Standby mode**. In this case, the Cortex<sup>®</sup>-A35 (CPU1) is set as master and the Cortex<sup>®</sup>-M33 (CPU2) follows the Cortex<sup>®</sup>-A35:
  - a. A CPU1 reset occurs, then CPU1 reboots from the boot ROM which jumps to the software present in the **SYSRAM**.
  - b. **DDR** exits from self-refresh by software running in **SYSRAM** (secure monitor).

**Note:** *The system enters in **Run1** once the CPU1 clocks are released. The Cortex<sup>®</sup>-M33 is running once the **DDR4** exits from self-refresh.*

**Table 14. PMIC configuration for standby DDR in self-refresh**

Regulator	PWRCTRLx assignment	Register xxxx_MAIN_CR		Register xxxx_ALT_CR	
		Configuration	VOUT	Configuration	VOUT
BUCK1 (V <sub>DDCPU</sub> )	PWR_CPU_ON	ON HP	0.8	OFF	-
BUCK2 (V <sub>DDCORE</sub> )	PWR_ON	ON HP	0.82	OFF	-
BUCK3 (V <sub>DDGPU</sub> )	-	ON/OFF HP <sup>(1)</sup>	-	-	-
BUCK4 (V <sub>DDIO</sub> )	PWR_ON	ON HP	3.3	ON HP	3.3
LDO1 (V <sub>DDA1V8_AON</sub> )	-	ON	N/A	-	N/A
BUCK5 (1V8)	PWR_ON	ON HP	1.8	OFF	-
BUCK6 (V <sub>DD_DDR</sub> )	PWR_ON	ON HP	1.2	ON HP	1.2
BUCK7 (3V3)	PWR_ON	ON HP	3.3	OFF	-
REFDDR	PWR_ON	ON	N/A	ON	N/A
LDO5 (V <sub>PP_DDR</sub> )	PWR_ON	ON	2.5	ON	2.5
LDO2 (V <sub>DD_eMMC</sub> )	NRSTC1MS <sup>(2)</sup>	ON	3.3	-	-
LDO3 (V <sub>TT_DDR</sub> )	PWR_ON	SINK SOURCE	-	OFF	-
LDO4 (V <sub>DD3V3_USB</sub> )	-	ON/OFF <sup>(3)</sup>	N/A	-	N/A

1. V<sub>DDGPU</sub> must be turned OFF before V<sub>DDCORE</sub> is turned OFF
2. The LDO2 is controlled from PWRCTRL3 in reset mode (PMIC PWRCTRL\_RST bit set for LDO2)
3. V<sub>DD3V3\_USB</sub> must be turned OFF before V<sub>DDCORE</sub> is turned OFF

**Note:** If SD-Card (UHS-I) is the boot flash memory, use the STPMIC25D (see Section 4.1.8: SD-Card power domains (V<sub>DD\_SDCARD</sub>, V<sub>DDIO\_SDCARD</sub>)). In that case LDO7 (V<sub>DD\_SDCARD</sub>) and LDO8 (V<sub>DDIO\_SDCARD</sub>) must be assigned to NRSTC1MS (PWRCTRL3) as the LDO2 on the Table 14 by setting their respective PWRCTRL\_RST bit.

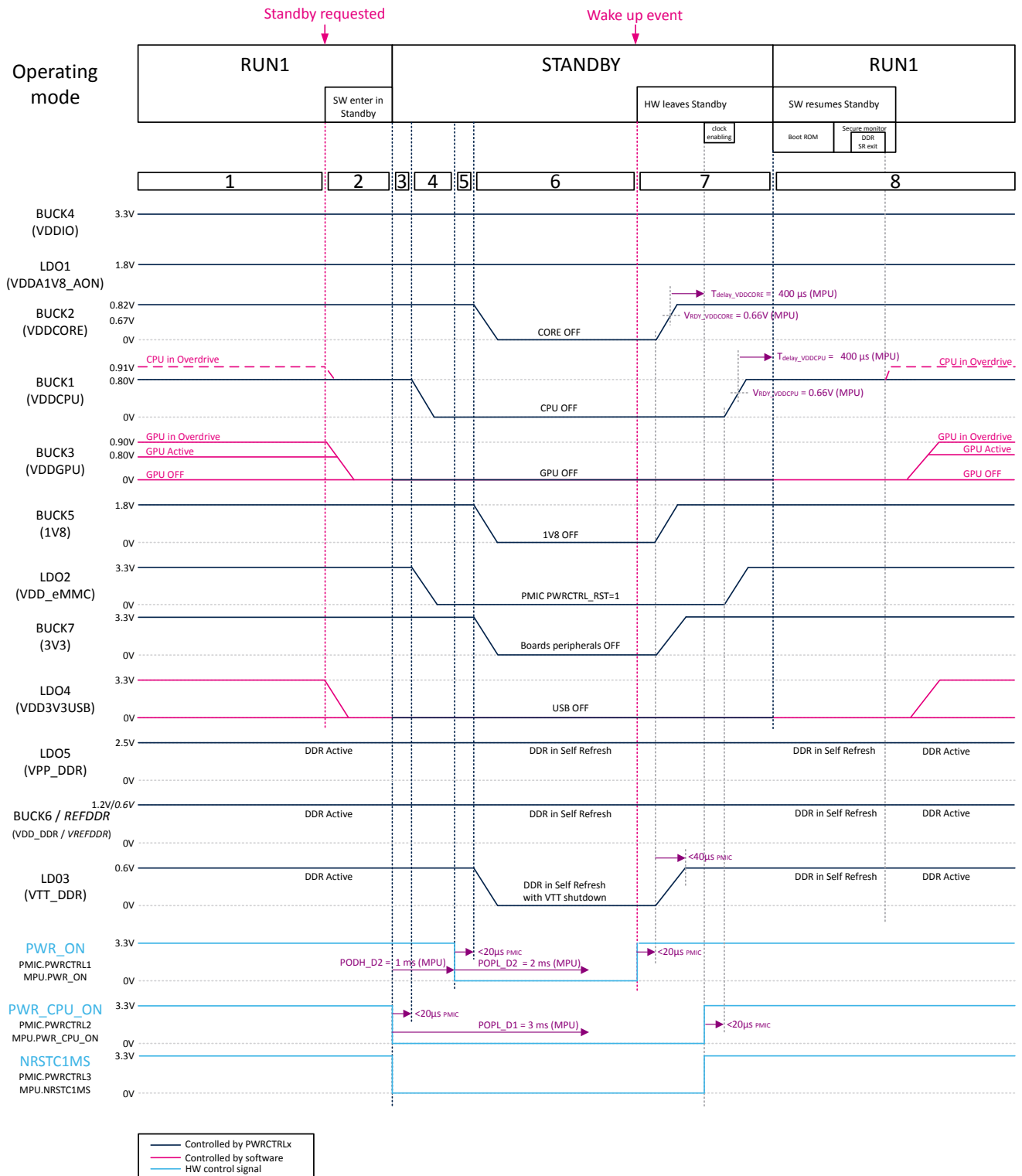
**Figure 11. Standby (DDR in self-refresh) sequence**

### 5.3.5 Standby mode (DDR4 OFF)

The **Standby mode** is used when a very-low power consumption is required. In this mode, the PMIC PWRCTRLx signals are set low. Most of the PMIC regulators are switched off. The content of MPU registers and memories are lost except for the backup and the retention domain ( $V_{DDIO}$  and  $V_{DDA1V8\_AON}$  are kept enabled). The DDR4 is powered off to maintain the system in “suspend to flash state.”

On the PMIC side, the **PWRCTRL1** is used to switch the state machine from RUN to STANDBY state (see details in [2]) in addition to switch OFF regulators linked to D2 domain (**PWR\_ON**).

This section focuses on the **Standby mode** with DDR4 OFF. This mode is described below and is shown in **Figure 12** based on the implementation shown in **Figure 1**.

1. The application is powered up and operating in **Run1** mode. All **PWR\_ON** and **PWR\_CPU\_ON** are in high state.
2. When the **Standby mode** is requested, the software prepares to enter **Standby mode**:
  - a. The MPU configures the PMIC as described in **Table 15**.
  - b. If CPU1 is in overdrive mode, the software sets CPU1 to nominal mode and sets **VDDCPU** to nominal voltage (from 0.91 V to 0.8 V).
  - c. The MPU disables the GPU then turns OFF the **VDDGPU** regulator.
  - d. The MPU disables the USB then turns OFF the **VDD3V3\_USB** regulator.
  - e. The MPU performs internal settings such as:
    - i. Set the **PWR\_D1CR[POPL\_D1]** = 3 ms timer, to define a minimum pulse duration of **PWR\_CPU\_ON** ensuring full discharge of the **VDDCPU** voltage before restarting.
    - ii. Set the **PWR\_D2CR[PODH\_D2]** = 1 ms timer, to turn off **VDDCPU** before **VDDCORE**.
    - iii. Set the **PWR\_D2CR[POPL\_D2]** = 2 ms timer, to define a minimum pulse duration of **PWR\_ON** ensuring full discharge of the **VDDCORE** voltage before restarting.
    - iv. Stop all system clocks that are not required.
    - v. Disable DDR.
  - f. Turns OFF the DDR regulators according to the power down sequence defined in **Section 4.1.6: DDR power domain** (**VDD\_DDR**, **VTT\_DDR**, **VPP\_DDR**, **VREF\_DDR**).
  - g. The **PWR\_CPU2CR[PDDS\_D2]** bit is enabled. **Standby mode** is allowed when CPU2 goes OFF.
  - h. The **PWR\_CPU1CR[PDDS\_D1]** and **PWR\_CPU1CR[PDDS\_D2]** bit are enabled. This allows the D1 domain to enter in DStandby (**VDDCPU** switched OFF), and the **Standby mode** is allowed when CPU1 is turned off.
3. Once the system is in **Standby mode**
  - a. The MPU **PWR\_CPU\_ON** is de-asserted, the PMIC **PWRCTRL2** goes low.
  - b. The **NRSTC1MS** signal follows the **PWR\_CPU\_ON** signal (PMIC **PWRCTRL3** goes low)
  - c. The **POPL\_D1** timer is started to keep the D1 domain powered off until **POPL\_D1** timer has elapsed (wake-up event is shifted until **POPL\_D1** has elapsed).
  - d. The **PODH\_D2** timer is started to keep **VDDCORE** enabled (**PWR\_ON** keeps high) waiting for **VDDCPU** voltage to be powered off before **VDDCORE**.
4. After 20  $\mu$ s internal PMIC delay, the PMIC regulators assigned to **PWR\_CPU\_ON** (linked to **PWRCTRL2**) and **NRSTC1MS** (linked to **PWRCTRL3**) takes the configuration set in the **xxxx\_ALT\_CR** registers (see **Table 15**).
  - a. **VDDCPU** regulator is turned OFF
  - b. **VDD\_eMMC** regulator is turned OFF
5. Once the **PODH\_D2** timer has elapsed
  - a. The MPU **PWR\_ON** is deasserted (PMIC **PWRCTRL1** goes low)
  - b. The **POPL\_D2** delay is started to keep the D2 domain powered off until the **POPL\_D2** timer has elapsed. The wake-up event is shifted until **POPL\_D2** has elapsed.
6. After 20  $\mu$ s internal PMIC delay, the PMIC regulators assigned to **PWR\_ON** (linked to **PWRCTRL1**) takes the configuration set in the **xxxx\_ALT\_CR** registers (see **Table 15**).
  - a. **VDDCORE** regulator is turned OFF.
  - b. **1V8** regulator is turned OFF.
  - c. **Section 4.1.11: 3V3** regulator is turned OFF.

7. On a wake-up event, the MPU leaves the low power mode:
  - a. The MPU `PWR_ON` signal is asserted (PMIC `PWRCTRL1` goes high).
  - b. After 20  $\mu$ s internal PMIC delay, the PMIC regulators assigned to `PWR_ON` takes on the configuration set in the `xxxx_MAIN_CR` registers (see [Table 15](#)):
    - [Section 4.1.11: 3V3](#) regulator is turned ON.
    - [1V8](#) regulator is turned ON.
    - `VDDCORE` regulator is turned ON.
  - c. Once the `VDDCORE` voltage reaches the `VRDY_VDDCORE` threshold, the `Tdelay_VDDCORE` internal delay starts to allow the `VDDCORE` to reach its minimum operating voltage value.
  - d. Once the `Tdelay_VDDCORE` delay is elapsed, the clocks are enabled and the MPU `PWR_CPU_ON` is asserted. The `NRSTC1MS` signal follows `PWR_CPU_ON`.
  - e. After 20  $\mu$ s internal PMIC delay, the PMIC regulators assigned to `PWR_CPU_ON` and `NRSTC1MS` takes the configuration set in the `xxxx_MAIN_CR` registers (see [Table 15](#)):
    - i. `VDD_eMMC` regulator is turned ON.
    - ii. `VDDCPU` regulator is turned ON.
  - f. Once the `VDDCPU` voltage reaches the `VRDY_VDDCPU` threshold, the `Tdelay_VDDCPU` internal delay starts to allow the `VDDCPU` to reach its nominal minimum operating voltage value.
8. Once `Tdelay_VDDCPU` is elapsed, CPU1 releases the clock domain to enter in `Run1` mode and the system resumes from `Standby mode`.
  - a. The D1 CPU starts to execute the boot ROM, and the `EADLY` timer starts.
  - b. Once the `EADLY` timer elapses, the boot ROM reads, verifies, and executes the bootloader from the external flash memory (eMMC).
9. The bootloader software performs initializations, then loads and executes the application software:
  - a. The bootloader software turns ON the DDR regulators according to the power up sequence defined in [Section 4.1.6: DDR power domain \(`VDD\_DDR`, `VTT\_DDR`, `VPP\_DDR`, `VREF\_DDR`\)](#).
  - b. The bootloader software initializes the DDR4 controller and DDR memory ICs.
  - c. The bootloader software resumes `Standby mode` by loading the application software from eMMC into DDR4 and executes it. The application is resumed, and the system is running.

**Table 15. PMIC configuration standby DDR OFF**

Regulator	PWRCTRLx assignment	Register xxxx_MAIN_CR		Register xxxx_ALT_CR	
		Configuration	VOUT	Configuration	VOUT
BUCK1 (V <sub>DDCPU</sub> )	PWR_CPU_ON	ON HP	0.8	OFF	-
BUCK2 (V <sub>DDCORE</sub> )	PWR_ON	ON HP	0.82	OFF	-
BUCK3 (V <sub>DDGPU</sub> )	-	ON/OFF HP <sup>(1)</sup>	0.8	-	-
BUCK4 (V <sub>DDIO</sub> )	PWR_ON	ON HP	3.3	ON LP	3.3
LDO1 (V <sub>DDA1V8_AON</sub> )	-	ON	N/A	-	N/A
BUCK5 (1V8)	PWR_ON	ON HP	1.8	OFF	-
BUCK6 (V <sub>DD_DDR</sub> )	PWR_ON	ON HP <sup>(2)</sup>	1.2	OFF	-
BUCK7 (3V3)	PWR_ON	ON HP	3.3	OFF	-
VREF_DDR	PWR_ON	ON <sup>(2)</sup>	N/A	OFF	-
LDO5 (V <sub>PP_DDR</sub> )	PWR_ON	ON <sup>(2)</sup>	2.5	OFF	-
LDO2 (V <sub>DD_eMMC</sub> )	NRSTC1MS <sup>(3)</sup>	ON/OFF	3.3	-	-
LDO3 (V <sub>TT_DDR</sub> )	PWR_ON	SINK SOURCE <sup>(2)</sup>	-	OFF	-
LDO4 (V <sub>DD3V3_USB</sub> )	-	ON/OFF <sup>(4)</sup>	N/A	-	N/A

1. V<sub>DDGPU</sub> must be turned OFF before V<sub>DDCORE</sub> is turned OFF
2. DDR4 regulators are turned OFF by software prior Standby mode entry
3. The LDO2 is controlled from PWRCTRL3 in reset mode (PMIC PWRCTRL\_RST bit set for LDO2)
4. V<sub>DD3V3\_USB</sub> must be turned OFF before V<sub>DDCORE</sub> is turned OFF

**Note:** If SD-Card (UHS-I) is the boot flash memory, use the STPMIC25D (see Section 4.1.8: SD-Card power domains (V<sub>DD\_SDCARD</sub>, V<sub>DDIO\_SDCARD</sub>). In that case LDO7 (V<sub>DD\_SDCARD</sub>) and LDO8 (V<sub>DDIO\_SDCARD</sub>) must be assigned to NRSTC1MS (PWRCTRL3) as the LDO2 on the Table 15 by setting their respective PWRCTRL\_RST bit.

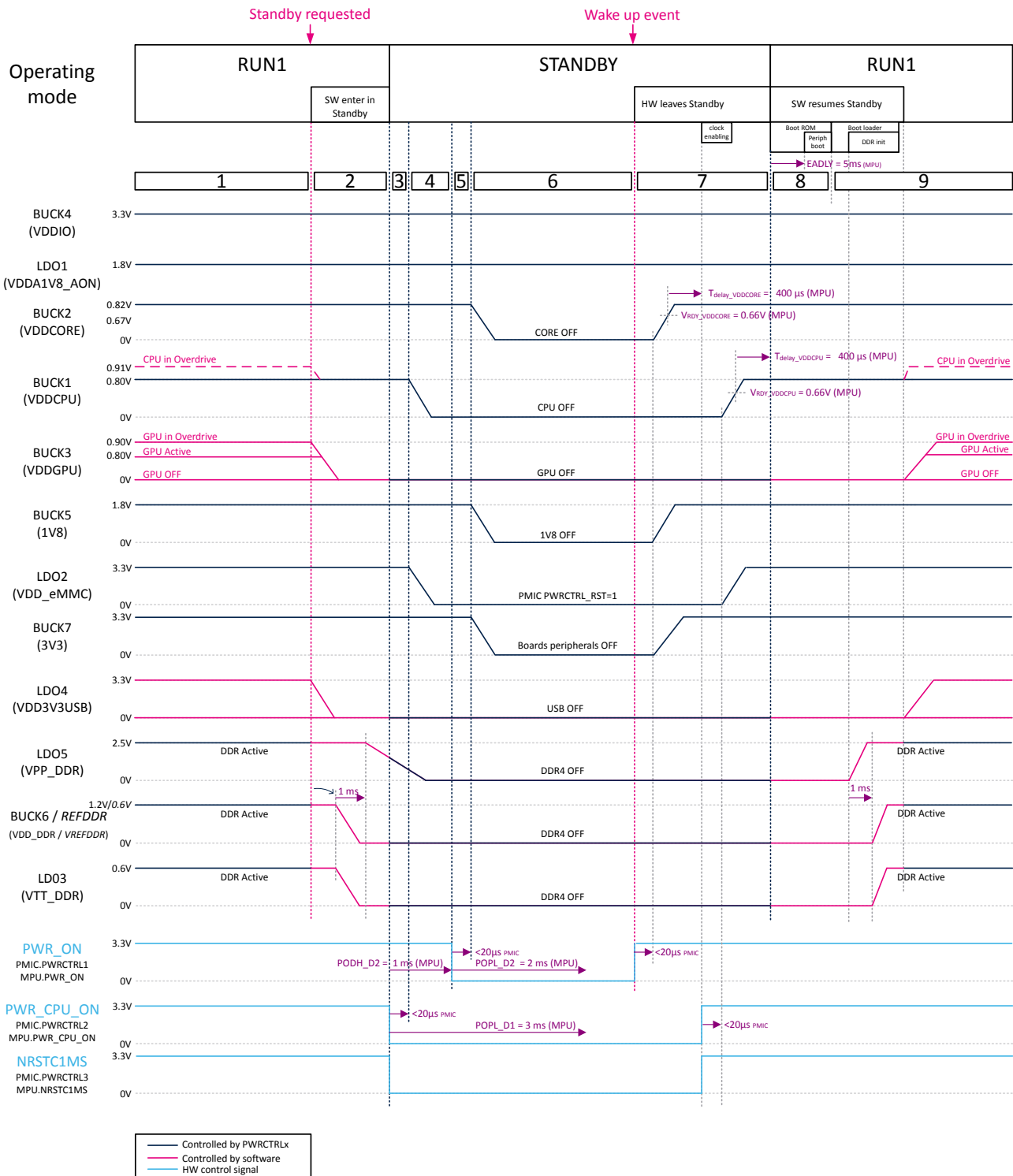
**Figure 12. Standby (DDR OFF) sequence**

## 5.4 System and CPU1 crash recovery management

The MPU can recover from several levels of crash. A crash could occur on the entire system or only to CPU1. These are described in the following list:

- A system crash: the complete application requires reset (system reset).
- A CPU1 crash: the crash is limited to the dual Arm® Cortex®-A35 platform (CPU1 is in the D1 domain). So, only the dual Arm® Cortex®-A35 and associated peripherals need to be reset.

### 5.4.1 System crash recovery management

As introduced in the [RSTn pin](#) section, the MPU, and the PMIC both have interconnected bidirectional low reset pins (see [Figure 1](#) NRST signal).

A system crash occurs when one or several of the following fail:

- MPU D1, D2, or D3 domain crash through watchdogs elapsing:
  - iwdg1\_out\_rst
  - iwdg2\_out\_rst
  - iwdg3\_out\_rst
  - iwdg4\_out\_rst
  - iwdg5\_out\_rst.
- System reset: such as the assertion of NRST by an external source by pressing on the reset button.
- PMIC hard-fault (see [Section 6: Safety management](#))

If a STM32MP25x crash occurs, the MPU generates a reset pulse on the NRST signal.

The reset pulse triggers the PMIC to produce an immediate power cycle sequence. This power cycling is recommended to ensure a correct reset and restart of the peripherals following a global application reset (NRST). This is specifically for peripherals that do not have a reset input signal such as eMMC and so on.

In this application, the power cycling is not performed on the PMIC [BUCK4 \(VDDIO\)](#), neither on the [LDO1 \(VDDA1V8\\_AON\)](#) due to the mask reset option. With this option, the regulators need to be kept enable during reset (see [Section 5.1.3: PMIC mask-reset option](#) for details).

The diagram in [Figure 13](#) illustrates a crash recovery or a system reset sequence according to the application shown in [Figure 1](#). For example, the crash is triggered by a IWDG reset occurring in Run mode, or the system reset is triggered by a user pushing the reset button.

**Note:** *An IWDG reset can occur in all low-power modes.*

1. The application is powered up and is in Run mode.
  2. A crash occurs when one of the MPU watchdogs elapses, or the user presses the reset button generating a pulse on the NRST signal. The PMIC detects the reset assertion (NRST pulse low) and starts a uninterruptible power cycle: The PMIC performs a power-down sequence:
    - a. The PMIC asserts the RSTn, asserting the MPU NRST signal and the MPU NRSTC1MS signal.
    - b. RANK0 (1.5 ms): The [BUCK3 \(VDDGPU\)](#), the [LDO7 \(VDD\\_SDCARD\)](#), the [LDO8 \(VDDIO\\_SDCARD\)](#), the [LDO5 \(VPP\\_DDR\)](#), [BUCK6 \(VDD\\_DDR\)](#), [REFDDR \(VREF\\_DDR\)](#), and [LDO3 \(VTT\\_DDR\)](#) are disabled.
    - c. RANK5 (1.5 ms): The [LDO4 \(VDD3V3\\_USB\)](#).
    - d. RANK4 (1.5 ms): The [BUCK7 \(3V3\)](#) and the [LDO2 \(VDD\\_eMMC\)](#) are disabled
- Note:** *If STPMIC25D is used, it disables the [LDO7 \(VDD\\_SDCARD\)](#) and the [LDO8 \(VDDIO\\_SDCARD\)](#). See [Section 4.1.8: SD-Card power domains \(VDD\\_SDCARD, VDDIO\\_SDCARD\)](#).*
- e. RANK3 (1.5 ms): The [BUCK1 \(VDDCPU\)](#) and the [BUCK5 \(1V8\)](#) are disabled.
  - f. RANK2 (1.5 ms): The [BUCK2 \(VDDCORE\)](#) is disabled. Once the [VDDCORE](#) voltage is below MPU [VRDY\\_VDDCORE](#) falling threshold, the MPU [PWR\\_CPU\\_ON](#) signals goes low.
  - g. RANK1 (1.5 ms): The [BUCK4 \(VDDIO\)](#) and the [LDO1 \(VDDA1V8\\_AON\)](#) are keep enabled as they are masked in reset sequence (See [Section 5.1.3: PMIC mask-reset option](#) for details).
3. Once the PMIC ends the power down sequence, it goes in *CHECK&LOAD* state to prepare the power-up sequence and to check if power-up conditions are fulfilled.

4. Once the *CHECK&LOAD* states ends, the PMIC starts a power-up sequence. The STPMIC25A regulators follow the power-up sequence predefined in its NVM:
  - a. RANK1 (1.5 ms): The **BUCK4** ( $V_{DDIO}$ ) is already enabled at 3.3 V and the **LDO1** ( $V_{DDA1V8\_AON}$ ) is already enabled at 1.8 V.

*Note:* *NRST signal is kept low as the PMIC asserts the NRST signal until the end of the power-up sequence*

- b. RANK2 (1.5 ms): The **BUCK2** ( $V_{DDCORE}$ ) is enabled at 0.82 V. Once  $V_{DDCORE}$  voltage is above MPU  $V_{RDY\_VDDCORE}$  threshold (0.66 V), a MPU  $T_{delay\_VDDCORE}$  (400  $\mu$ s typ.) delay is started to wait for  $V_{DDCORE}$  voltage to reach minimum operating voltage. Once  $T_{delay\_VDDCORE}$  elapses, the MPU starts hardware initialization such as: starting the HSI oscillator and so on, and the **PWR\_CPU\_ON** signal goes high.
- c. RANK3 (1.5 ms): The **BUCK1** ( $V_{DDCPU}$ ) is enabled at 0.80 V and the **BUCK5** (1V8) is enabled at 1.8 V. Once  $V_{DDCPU}$  voltage is above MPU  $V_{RDY\_VDDCPU}$  threshold (0.66 V), a MPU  $T_{delay\_VDDCPU}$  (400  $\mu$ s typ.) delay is started to wait for  $V_{DDCPU}$  voltage to reach minimum operating voltage. Once  $T_{delay\_VDDCPU}$  elapses, the MPU is ready to boot but it keeps in reset until the PMIC releases the NRST signal.
- d. RANK4 (1.5 ms): the **BUCK7** (3V3) and **LDO2** ( $V_{DD\_eMMC}$ ) are enabled at 3.3 V.

*Note:* *If the STPMIC25D used, it enables the LDO7 ( $V_{DD\_SDCARD}$ ) and the LDO8 ( $V_{DDIO\_SDCARD}$ ) in bypass mode allowing to boot over SD-Card UHS-I. See Section 4.1.8: SD-Card power domains ( $V_{DD\_SDCARD}$ ,  $V_{DDIO\_SDCARD}$ ).*

- e. RANK5 (1.5 ms): **LDO4** ( $V_{DD3V3\_USB}$ ) is enabled.
  - f. Once RANK5 is ended, the PMIC releases the RSTn that releases MPU NRST.
5. Once the NRST is released, the MPU enters in Run mode:
    - a. The MPU releases the NRSTC1MS signal.
    - b. The D1 CPU starts to execute the boot ROM: **EADLY** timer starts.
    - c. Once **EADLY** elapses, the boot ROM reads, verifies, and executes the bootloader from the external flash memory (eMMC).
  6. The bootloader software performs initializations, then loads and executes the application software:
    - a. The software enable **LDO5** ( $V_{PP\_DDR}$ ) at 2.5 V.
    - b. The software waits for 1 ms.
    - c. The software enables the following once the delay has elapsed:
      - **REFDDR** ( $V_{REF\_DDR}$ )
      - **LDO3** ( $V_{TT\_DDR}$ ) in sink-source mode
      - **BUCK6** ( $V_{DD\_DDR}$ ) at 1.2 V.
    - d. The software waits for 1 ms.
    - e. The MPU software initializes the DDR4 controller and DDR memory ICs.
    - f. The bootloader loads the application software into DDR4 and executes it. The kernel initializes.
    - g. The system is now running. The application software can enable the GPU (**BUCK3** ( $V_{DDGPU}$ )) and the SD-Card (**LDO7** ( $V_{DD\_SDCARD}$ ) and the **LDO8** ( $V_{DDIO\_SDCARD}$ )).

Figure 13. System crash recovery sequence

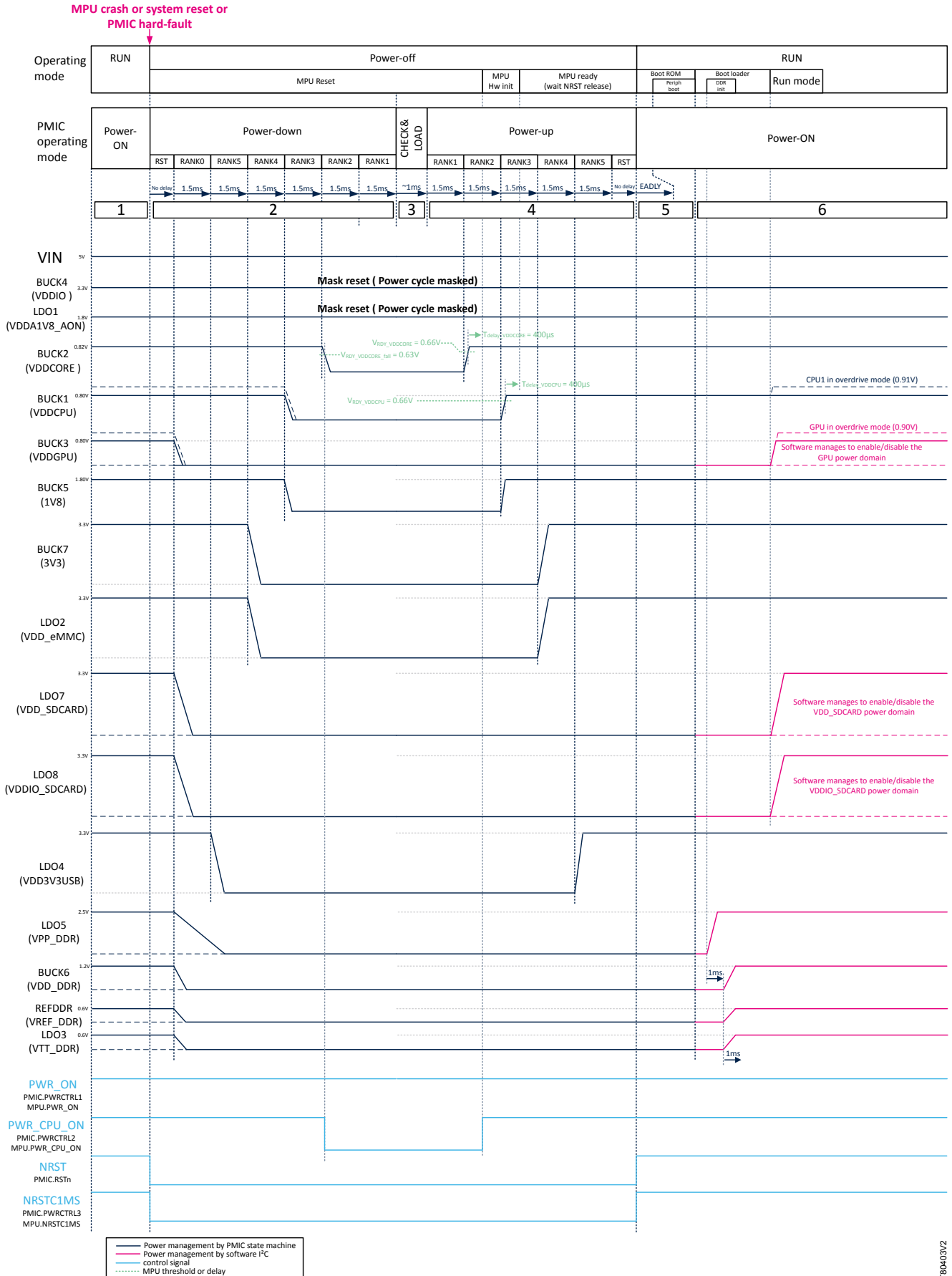

### 5.4.2 CPU1 crash recovery management

As introduced in the [PWRCTRL1](#), [PWRCTRL2](#), [PWRCTRL3](#) section, the NRSTC1MS pin is dedicated to reset peripherals associated with the CPU1, specifically for the flash memory boot device.

If a crash occurs on CPU1, only D1 domain is reset; the CPU2 on D2 domain is not affected and continues to run:

1. The application is powered up and is in Run mode.
2. A CPU1 crash occurs, triggered by the watchdog elapsing on CPU1, then the MPU resets the CPU1.
3. Once the MPU releases the CPU1 reset, the CPU1 executes the boot ROM.
4. The boot ROM software generates a pulse on NRSTC1MS (see [C1MSRD timer](#) section):
  - a. The [C1MSRD timer](#) started.
  - b. The NRSTC1MS signal is set low by MPU: the [LDO2](#) ( $V_{DD\_eMMC}$ ), assigned to NRSTC1MS ([PMICPWRCTRL3](#)), is powered OFF.
5. Once [C1MSRD timer](#) timer elapses (2 ms), the NRSTC1MS signal is set high by the MPU:
  - The [LDO2](#) is turned ON with the default voltage set in the PMIC NVM.
6. The boot ROM starts the [EADLY](#) timer (5 ms) to wait for [LDO2](#) ( $V_{DD\_eMMC}$ ) voltage to stabilize and the eMMC flash memory to initialize.
7. Once the [EADLY](#) elapses, the boot ROM reads, verifies, and executes the bootloader from the external flash memory (eMMC).
  - The bootloader software performs the CPU1 initializations, then loads and executes the CPU1 application software.

**Note:** *If a SD-Card (supporting UHS-I mode) is the boot flash memory, use the [STPMIC25D](#) to support the CPU1 crash recovery management. See [Section 4.1.8: SD-Card power domains \( \$V\_{DD\\_SDCARD}\$ ,  \$V\_{DDIO\\_SDCARD}\$ \)](#) for details.*

## 6 Safety management

In this document, the safety management is the concept of implementing mechanisms such as over current protection (OCP), watchdogs, and so on, to maintain the system functional and robust. The objective is to protect the safety and integrity of the application against internal or external errors, or dysfunctions.

The safety management is provided by the MPU software and/or by the PMIC functionalities.

This section focuses on PMIC safety management functionalities. It is based on failure detection (hard fault) and related PMIC behavior such as fail-safe management.

Refer to [2] for more details.

### 6.1 PMIC fail-safe management

Each source of hard fault as defined in [Section 6.2: PMIC hard-faults](#) has a dedicated independent fail-safe counter. This counter, named `xxxx_FLT_CNT` (where `xxxx` is the hard fault source), is incremented each time a hard fault event occurs, in addition to a turn-off condition.

The maximum fault iteration counter, `xxxx_FLT_CNT_MAX` set in PMIC NVM, is used to define the maximum number of the hard fault iterations before the PMIC enters into `FAIL_SAFE_LOCK` state. By default, there is no limit applied any of the hard-fault counter on either the STPMIC25A and STPMIC25D. It means that STPMIC25A and STPMIC25D always restarts after a hard fault event occurs and never enters in `FAIL_SAFE_LOCK` state.

As long as the fail-safe counter `xxxx_FLT_CNT` does not reach the `xxxx_FLT_CNT_MAX` value, the PMIC carries out a power cycle each time a hard fault event occurs. A power cycle is defined by:

1. a power-down sequence
2. waits for `FLT_TMR` (fault timer) to end
3. runs a power-up sequence as defined in [Section 5.4.1: System crash recovery management](#)

Once the number of hard fault iterations exceed the `xxxx_FLT_CNT_MAX` counter, the system is blocked in `FAIL_SAFE_LOCK` state. To exit this state, the PMIC must carry out a main supply removal or a `PONKEYn` long press (a special NVM setting is necessary).

The `RST_FLT_CNT_TMR` reset fault timer may be enabled by NVM to automatically clear all `xxxx_FLT_CNT` fail-safe counters if no hard fault has occurred until `RST_FLT_CNT_TMR` elapses.

The following examples illustrate fail-safe management mechanisms.

#### Example 1: STPMIC25A behavior with a negative voltage glitch on $V_{IN}$

The initial condition is the STPMIC25A NVM has the default value.

The `VIN_FLT_CNT_MAX` counter is configured in the NVM fail-safe shadow register `NVM_FS_SHR1`, to 1111 (infinite hard fault configuration).

##### Description:

A 5 V wall adapter is plugged to the application main supply connector. The  $V_{IN}$  rises above  $V_{INOK\_rise}$  (4 V), the PMIC then powers up the application and the application initializes. A negative voltage glitch occurs on  $V_{IN}$  due to bad contact at main supply connector. This causes a glitch voltage to fall below  $V_{INOK\_fall}$  (3.5 V). The PMIC causes a  $V_{IN}$  hard fault condition that triggers a power-off sequence and the `VIN_FLT_CNT` dedicated fail-safe counter is incremented by one. Once the power-off sequence is completed, the PMIC evaluates the state transition and goes to the power-up sequence as long as  $VIN\_FLT\_CNT \leq VIN\_FLT\_CNT\_MAX$ .

Once the power-up sequence ends, PMIC goes in power-on state and the application initializes and runs.

If several other negative glitches occur on the main supply input ( $V_{IN}$ ) below  $V_{INOK\_fall}$ , the STPMIC25A always restarts as  $VIN\_FLT\_CNT \leq VIN\_FLT\_CNT\_MAX$  is always true.

This behavior is identical for other hard fault sources: the STPMIC25A always restarts.

#### Example 2: STPMIC25A behavior with negative voltage glitch on $V_{IN}$ and tuned fail-safe management in STPMIC25A NVM

The initial condition is the STPMIC25A NVM has been tuned to adjust fail-safe management as follows:

- `VIN_FLT_CNT_MAX[3:0] = 0x0001` programmed in PMIC `NVM_FS_SHR1` NVM. This specifies that one hard fault on  $V_{IN}$  is allowed.
- `RST_FLT_CNT_TMR[1:0] = 0x10` programmed in PMIC `NVM_FS_SHR2` NVM. This specifies that all fault counters are cleared if no hard fault is detected for six min.

### Description

A 5 V wall adapter is plugged to the application main supply connector. The  $V_{IN}$  rises above  $V_{INOK\_rise}$  (4 V), the PMIC then powers up the application and the application initializes. A negative voltage glitch occurs on  $V_{IN}$  due to bad contact at main supply connector. This causes a glitch voltage to fall below  $V_{INOK\_fall}$  (3.5 V). The PMIC causes a  $V_{IN}$  hard fault condition that triggers a power-off sequence. The  $VIN\_FLT\_CNT$  dedicated fail-safe counter is incremented by one. Once the power-off sequence is completed, the PMIC evaluates the state transition and goes to the power-up sequence as  $VIN\_FLT\_CNT \leq VIN\_FLT\_CNT\_MAX$  condition is true. Once the power-up sequence ends, the PMIC goes in power-on state and the application initializes and runs.

- If another negative voltage glitch on  $V_{IN}$  occurs before the  $RST\_FLT\_CNT\_TMR$  elapses, within the following six minutes, the PMIC causes a  $V_{IN}$  hard fault condition that triggers a power-off sequence. The dedicated  $VIN\_FLT\_CNT$  fail-safe counter is incremented by one (the content is two). Once the power-off sequence ends, the PMIC evaluates state transition which states that  $VIN\_FLT\_CNT \leq VIN\_FLT\_CNT\_MAX$  condition is wrong. The PMIC goes in  $FAIL\_SAFE\_LOCK\_STATE$  and is locked in this state until next PMIC POR (main supply removal).
- If another negative voltage glitch on  $V_{IN}$  occurs after the  $RST\_FLT\_CNT\_TMR$  elapses, within the following six minutes, all  $xxx\_FLT\_CNT$  are cleared including the  $VIN\_FLT\_CNT$ . Then, if a new negative glitch on  $V_{IN}$  occurs, the PMIC enters power-off and then it powers up as  $VIN\_FLT\_CNT \leq VIN\_FLT\_CNT\_MAX$  condition is true.

Figure 14. PMIC fail-safe management mechanism

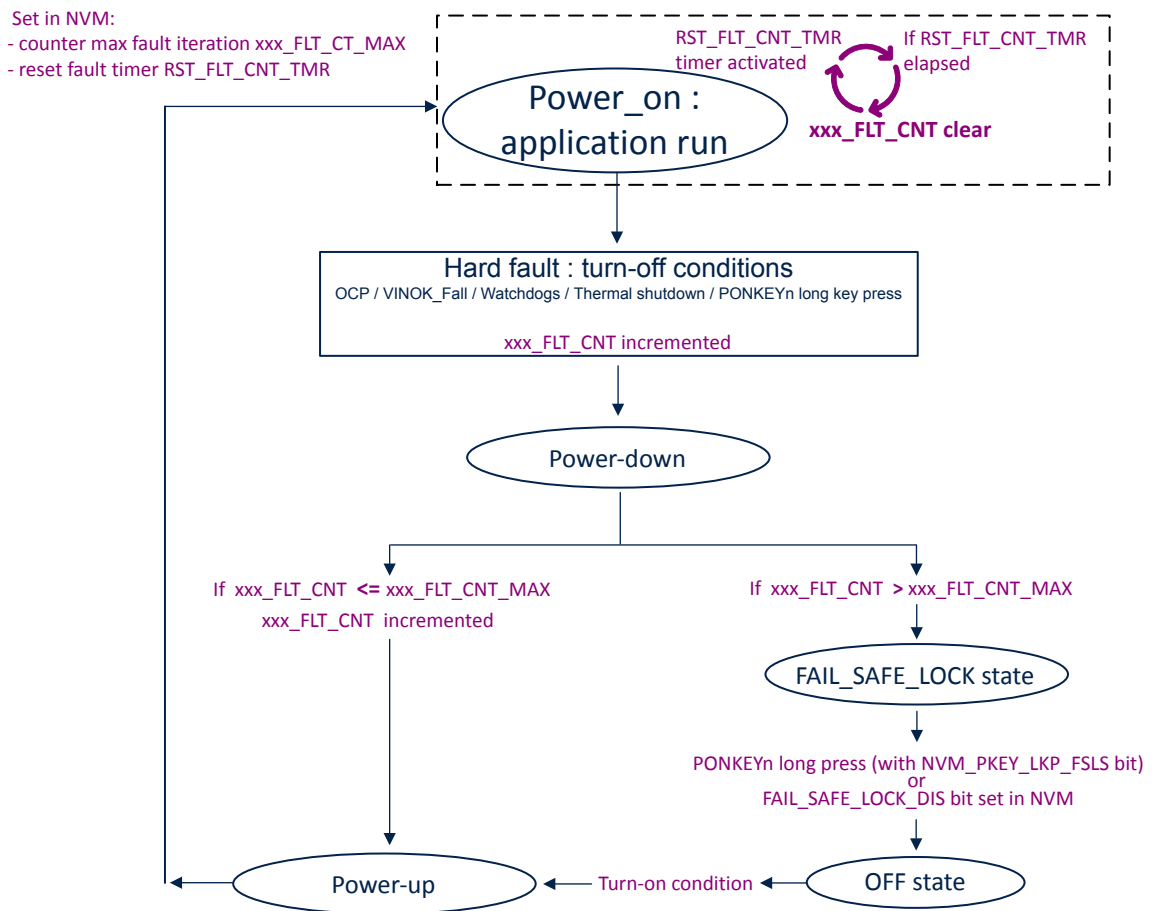

## 6.2 PMIC hard-faults

The PMIC considers five hardware source events as hard-fault conditions:

- **OCP**: Overcurrent protection, including short circuit
- **VIN**: Undervoltage protection where  $V_{IN}$  falls below  $V_{INOK\_fall}$  threshold
- **TSHDN**: Thermal shutdown protection
- **WDG**: Watchdog timer expiration
- **PKEY**: Power on key button long press

Each hard-fault source is managed in the same way:

- A turn-off condition is triggered (see [Turn-off conditions](#) ) followed by PMIC power-down sequence
- Then, depending on fail-safe management settings, the PMIC can:
  - Restart automatically (power-up sequence). This is the default behavior of the STPMIC25A and the STPMIC25D.
  - Not restart automatically: PMIC is kept in FAIL\_SAFE\_LOCK or OFF state until an authorized turn-on condition is issued.

*Note:* It is implied, a hard-fault can occur only when PMIC is in power-on state.

### 6.2.1 OCP overcurrent protection

All the PMIC regulators implement two level of protection against overcurrent or short circuit on their output.

#### HICCUP (level 0)

In case of overcurrent or short-circuit, each PMIC regulator (set in level 0) operates independently in hiccup mode without impacting any other power domain of the application. This level of protection is suitable for non-critical power domains.

Once an OCP occurs, the regulator turns off for the  $t_{HICCUP\_DLY}$  timer to elapse. This delay is predefined in NVM, and then restarts.

Accordingly, the regulator restarts infinitely until the overcurrent/short-circuit disappears.

#### OCP hard-fault management (Level 1)

In case of overcurrent or short-circuit, a PMIC regulator set in level 1 triggers an OCP hard fault turn-off condition. This implies that the PMIC enters power-off state, and then power-on state (depending on fail-safe settings). This level of protection is suitable for the critical power domain, such as MPU  $V_{DDCORE}$ , DDR4 regulators, where it is mandatory to restart the application completely in case of overcurrent or short-circuit.

[Section 6.3: OCP management in the application](#) illustrates the STPMIC25A OCP settings based on the application in [Figure 1](#).

### 6.2.2 $V_{IN}$ undervoltage protection ( $V_{IN} < V_{INOK\_Fail}$ )

The PMIC embeds an undervoltage protection to prevent the MPU or peripherals from crashing in case the PMIC regulators are unable to maintain the correct regulation due to  $V_{IN}$  input voltage being too low.

Once the main  $V_{IN}$  supply goes below  $V_{INOK\_fall}$  threshold, even for a very short duration, such as a voltage glitch, generates a hard fault condition. This results in following steps:

1. the  $V_{IN}$  fail-safe counter ( $VIN\_FLT\_CNT$ ) is incremented
2. the PMIC powers down.

If the  $VIN\_FLT\_CNT$  counter is higher than the  $VIN\_FLT\_CNT\_MAX$  when power-down ends, the PMIC enters in FAIL\_SAFE\_LOCK state.

If the  $VIN\_FLT\_CNT$  counter does not exceed the  $VIN\_FLT\_CNT\_MAX$  when power-down ends, the PMIC waits for  $FLT\_TMR$  fault timer to elapse, where  $t_{VINOK\_Fail} = 100$  ms. The PMIC enters power-up and then goes to power-on. The application then initializes and runs.

### 6.2.3 TSHDN: thermal shutdown protection

The PMIC embeds a thermal protection to avoid any damage from the part overheating.

Two levels of thermal protection are available:

- First level, an interruption is sent to the MPU:  
Once the PMIC junction temperature goes higher than or below temperature thresholds (respectively  $T_{WRN\_Rise}$  or  $T_{WRN\_Fall}$ ), the PMIC generates an interrupt to be caught and managed by the MPU.
- Second level, hard fault condition is generated:  
Once the PMIC junction temperature exceeds the  $T_{SHDN\_Rise}$  temperature thresholds:
  1. a hard-fault condition is generated
  2. the thermal fail-safe counter (TSHDN\_FLT\_CNT) is incremented
  3. the PMIC enters power-down.
 If the TSHDN\_FLT\_CNT counter is higher than the TSHDN\_FLT\_CNT\_MAX when power-down ends, the PMIC enters in FAIL\_SAFE\_LOCK state.  
 If the TSHDN\_FLT\_CNT counter does not exceed the TSHDN\_FLT\_CNT\_MAX when power-down ends, the PMIC waits for:
  - FLT\_TMR fault timer to elapse, where  $t_{SHDN\_DLY} = 3$  s
  - PMIC junction temperature goes below  $T_{SHDN\_Fall}$  threshold

The PMIC enters power-up, and then goes to power-on. The application then initializes and runs.

### 6.2.4 WDG: watchdog timer expiration

The PMIC embeds a programmable watchdog that can be enabled at runtime by the software, or enabled by default at power-up (NVM setting):

- WDG\_TMR\_SET: watchdog timer duration value setting.
- WDG\_TMR\_CNT: watchdog timer down-counter.
- WDG\_EN: watchdog enable bit.
- WDG\_RST: watchdog clear bit. This bit must be periodically set by the MPU software to reset the watchdog timer.

*Note:* The PMIC PWRCTRLx input can be used to suspend the watchdog, typically in low-power mode. When the PWRCTRL is asserted in low-power mode, the watchdog timer is suspended. When this PWRCTRL is desasserted, the watchdog timer is resumed.

If the MPU software fails to clear the PMIC watchdog timer (WDG\_RST) bit, the watchdog timer elapses.

Once the PMIC watchdog timer elapses, a hard fault condition is generated:

- the watchdog fault counter (WDG\_FLT\_CNT) is incremented
- the PMIC enters power-down.

If the WDG\_FLT\_CNT counter is higher than the WDG\_FLT\_CNT\_MAX when power-down ends, the PMIC enters in FAIL\_SAFE\_LOCK state.

If the WDG\_FLT\_CNT counter does not exceed the WDG\_FLT\_CNT\_MAX when power-down ends, the PMIC enters power-up, then goes to power-on. The application then initializes and runs.

### 6.2.5 PKEY: power on key user button long press

A long press on the PONKEYn user button enables the PMIC hard fault condition to be triggered. It is similar to a system reset except that PMIC performs a power cycle in addition to asserting the reset signal.

The long press duration is set to 10 seconds by default with STPMIC25A and STPMIC25D. The NVM can be reprogrammed with one of the following configurations:

- Adjust the duration by modifying NVM\_PKEY\_LKP\_TMR bit
- Disable this feature by setting NVM\_PKEY\_LKP\_OFF bit.

Once the long key press PONKEYn timer elapses, by default set to 10 s, a hard fault condition is generated: the PKEY fail-safe counter (PKEY\_FLT\_CNT) is incremented and the PMIC enters power-down.

If the PKEY\_FLT\_CNT counter is higher than the PKEY\_FLT\_CNT\_MAX when power-down ends, the PMIC enters in FAIL\_SAFE\_LOCK state.

If the PKEY\_FLT\_CNT counter does not exceed the PKEY\_FLT\_CNT\_MAX when power-down ends, the PMIC enters power-up, and then goes to power-on. The application then initializes and runs.

### 6.3 OCP management in the application

In the application illustrated in Figure 1, the two levels of protection are applied on the regulators as follows:

- All critical regulators needed for the application are managed in OCP fail-safe (level 1), else in HICCUP (level 0).
- These settings can be modified by reprogramming the NVM\_FS\_OCP\_SHRx registers in PMIC NVM according to Table 16.

**Table 16. OCP management application**

Regulator	HICCUP	Fail Safe
BUCK1 (V <sub>DDCPU</sub> )	-	YES
BUCK2 (V <sub>DDCORE</sub> )	-	YES
BUCK3 (V <sub>DDGPU</sub> )	YES	-
BUCK4 (V <sub>DDIO</sub> )	-	YES
BUCK5 (1V8)	-	YES
BUCK6 (V <sub>DD_DDR</sub> )	-	YES
BUCK7 (3V3)	YES	-
V <sub>REF_DDR</sub>	-	YES
LDO1 (V <sub>DDA1V8_AON</sub> )	-	YES
LDO2 (V <sub>DD_eMMC</sub> )	YES	-
LDO3 (V <sub>TT_DDR</sub> )	-	YES
LDO4 (V <sub>DD3V3_USB</sub> )	YES	-
LDO5 (V <sub>PP_DDR</sub> )	-	YES
LDO6 (Free)	YES	-
LDO7 (V <sub>DD_SDCARD</sub> )	YES	-
LDO8 (V <sub>DDIO_SDCARD</sub> )	YES	-

*Note:* The table above applies to both STPMIC25A and STPMIC25D

## Revision history

Table 17. Document revision history

Date	Version	Changes
24-Sep-2025	1	Initial release.
05-Jan-2026	2	Document completely restructured
29-Apr-2026	3	Updated: <ul style="list-style-type: none"> <li>• Document title</li> <li>• Introduction</li> <li>• Section 1: General information</li> <li>• Section 2: Overview</li> <li>• Section 2.1: Reference documents</li> <li>• Section 4.1.5: V<sub>DD3V3_USB</sub> power domain</li> <li>• Section 4.1.6: DDR power domain (V<sub>DD_DDR</sub>, V<sub>TT_DDR</sub>, V<sub>PP_DDR</sub>, V<sub>REF_DDR</sub>)</li> <li>• Section 4.1.9: 1V8 power domain</li> <li>• Section 4.1.10: MPU backup domain and retention domain</li> <li>• Section 4.1.11: 3V3 external peripherals power domain</li> <li>• Section 4.2: Control signals between STPMIC25 and STM32MP25x</li> <li>• Section 4.2.1: STPMIC25A and STPMIC25D default behavior with STM32MP25x</li> <li>• Section 4.2.2: PMIC digital control interface</li> <li>• Section 5.1: Operating modes               <ul style="list-style-type: none"> <li>– Table 5. Operating modes</li> </ul> </li> <li>• Section 5.1.1: Application turn-on/turn-off conditions               <ul style="list-style-type: none"> <li>– Table 6. PMIC turn-on conditions</li> <li>– Table 7. PMIC turn off conditions</li> </ul> </li> <li>• Section 5.2.1: Power-up triggered by main supply (V<sub>IN</sub>) plugin/power-down by software shutdown               <ul style="list-style-type: none"> <li>– Figure 3. Power up and power-down sequence of the MPU with STPMIC25A</li> </ul> </li> <li>• Section 5.2.2: Power-down triggered by fast V<sub>IN</sub> drop               <ul style="list-style-type: none"> <li>– Figure 6. Uncontrolled power down sequence</li> </ul> </li> <li>• Section 5.3: Low power mode management               <ul style="list-style-type: none"> <li>– Table 8. Low power mode supported by the application</li> </ul> </li> <li>• Section 5.3.1: STM32MP25x internal timer for low power mode management</li> <li>• Section 5.3.2: LP-Stop1/LPLV-Stop1 mode               <ul style="list-style-type: none"> <li>– Table 10. PMIC configuration for LP-Stop1 mode</li> <li>– Table 11. PMIC configuration for LPLV-Stop1 mode</li> </ul> </li> <li>• Section 5.3.3: LP-Stop2/LPLV-Stop2 mode               <ul style="list-style-type: none"> <li>– Table 12. PMIC configuration for LP-Stop2</li> <li>– Figure 9. LP-Stop2 sequence</li> <li>– Table 13. PMIC configuration for LPLV-Stop2</li> <li>– Figure 10. LPLV-Stop2 sequence</li> </ul> </li> <li>• Section 5.3.4: Standby mode (DDR4 in self-refresh)               <ul style="list-style-type: none"> <li>– Table 14. PMIC configuration for standby DDR in self-refresh</li> <li>– Figure 11. Standby (DDR in self-refresh) sequence</li> </ul> </li> <li>• Section 5.3.5: Standby mode (DDR4 OFF)               <ul style="list-style-type: none"> <li>– Table 15. PMIC configuration standby DDR OFF</li> <li>– Figure 12. Standby (DDR OFF) sequence</li> </ul> </li> <li>• Figure 13. System crash recovery sequence</li> <li>• Section 6.1: PMIC fail-safe management</li> </ul>

## Contents

<b>1</b>	<b>General information</b> .....	<b>2</b>
<b>2</b>	<b>Overview</b> .....	<b>3</b>
<b>2.1</b>	Reference documents .....	<b>3</b>
<b>3</b>	<b>Glossary</b> .....	<b>4</b>
<b>4</b>	<b>5 V power supply application reference design</b> .....	<b>5</b>
<b>4.1</b>	Power distribution .....	<b>7</b>
<b>4.1.1</b>	V <sub>DDCPU</sub> power domain (800 mV/910 mV) .....	<b>7</b>
<b>4.1.2</b>	V <sub>DDCORE</sub> power domain (670 mV / 820 mV) .....	<b>7</b>
<b>4.1.3</b>	V <sub>DDGPU</sub> power domain (800 mV / 900 mV) .....	<b>8</b>
<b>4.1.4</b>	V <sub>DDIO</sub> and V <sub>DDA1V8_AON</sub> power domains .....	<b>8</b>
<b>4.1.5</b>	V <sub>DD3V3_USB</sub> power domain .....	<b>9</b>
<b>4.1.6</b>	DDR power domain (V <sub>DD_DDR</sub> , V <sub>TT_DDR</sub> , V <sub>PP_DDR</sub> , V <sub>REF_DDR</sub> ) .....	<b>9</b>
<b>4.1.7</b>	V <sub>DD_eMMC</sub> power domain (3.3 V) .....	<b>12</b>
<b>4.1.8</b>	SD-Card power domains (V <sub>DD_SDCARD</sub> , V <sub>DDIO_SDCARD</sub> ) .....	<b>13</b>
<b>4.1.9</b>	1V8 power domain .....	<b>14</b>
<b>4.1.10</b>	MPU backup domain and retention domain .....	<b>15</b>
<b>4.1.11</b>	3V3 external peripherals power domain .....	<b>16</b>
<b>4.2</b>	Control signals between STPMIC25 and STM32MP25x .....	<b>16</b>
<b>4.2.1</b>	STPMIC25A and STPMIC25D default behavior with STM32MP25x .....	<b>16</b>
<b>4.2.2</b>	PMIC digital control interface .....	<b>17</b>
<b>5</b>	<b>Power management</b> .....	<b>20</b>
<b>5.1</b>	Operating modes .....	<b>20</b>
<b>5.1.1</b>	Application turn-on/turn-off conditions .....	<b>22</b>
<b>5.1.2</b>	PMIC power control management (PWRCTRLx) .....	<b>23</b>
<b>5.1.3</b>	PMIC mask-reset option .....	<b>24</b>
<b>5.2</b>	Application Power-up/Power-down sequence .....	<b>24</b>
<b>5.2.1</b>	Power-up triggered by main supply (V <sub>IN</sub> ) plugin/power-down by software shutdown .....	<b>25</b>
<b>5.2.2</b>	Power-down triggered by fast V <sub>IN</sub> drop .....	<b>29</b>
<b>5.3</b>	Low power mode management .....	<b>34</b>
<b>5.3.1</b>	STM32MP25x internal timer for low power mode management .....	<b>35</b>
<b>5.3.2</b>	LP-Stop1/LPLV-Stop1 mode .....	<b>37</b>
<b>5.3.3</b>	LP-Stop2/LPLV-Stop2 mode .....	<b>43</b>
<b>5.3.4</b>	Standby mode (DDR4 in self-refresh) .....	<b>50</b>
<b>5.3.5</b>	Standby mode (DDR4 OFF) .....	<b>53</b>
<b>5.4</b>	System and CPU1 crash recovery management .....	<b>58</b>

---

5.4.1	System crash recovery management .....	58
5.4.2	CPU1 crash recovery management .....	61
<b>6</b>	<b>Safety management.....</b>	<b>62</b>
6.1	PMIC fail-safe management .....	62
6.2	PMIC hard-faults .....	64
6.2.1	OCP overcurrent protection.....	64
6.2.2	$V_{IN}$ undervoltage protection ( $V_{IN} < V_{INOK\_Fail}$ ).....	64
6.2.3	TSHDN: thermal shutdown protection .....	65
6.2.4	WDG: watchdog timer expiration.....	65
6.2.5	PKEY: power on key user button long press .....	65
6.3	OCP management in the application .....	66
	<b>Revision history .....</b>	<b>67</b>
	<b>List of figures.....</b>	<b>70</b>
	<b>List of tables .....</b>	<b>71</b>

## List of figures

<b>Figure 1.</b>	STM32MP25x and STPMIC25A with 2xDDR4, eMMC, SD-card . . . . .	6
<b>Figure 2.</b>	Backup and retention domain . . . . .	16
<b>Figure 3.</b>	Power up and power-down sequence of the MPU with STPMIC25A . . . . .	27
<b>Figure 4.</b>	Application PWR_ON and PWR_CPU_ON behavior during the power-up sequence . . . . .	28
<b>Figure 5.</b>	Application PWR_ON and PWR_CPU_ON behavior during power down sequence . . . . .	29
<b>Figure 6.</b>	Uncontrolled power down sequence . . . . .	33
<b>Figure 7.</b>	LP-Stop1 sequence. . . . .	39
<b>Figure 8.</b>	LPLV-Stop1 sequence . . . . .	42
<b>Figure 9.</b>	LP-Stop2 sequence. . . . .	46
<b>Figure 10.</b>	LPLV-Stop2 sequence . . . . .	49
<b>Figure 11.</b>	Standby (DDR in self-refresh) sequence . . . . .	53
<b>Figure 12.</b>	Standby (DDR OFF) sequence . . . . .	57
<b>Figure 13.</b>	System crash recovery sequence . . . . .	60
<b>Figure 14.</b>	PMIC fail-safe management mechanism . . . . .	63

## List of tables

<b>Table 1.</b>	Applicable products . . . . .	1
<b>Table 2.</b>	Reference documents . . . . .	3
<b>Table 3.</b>	Glossary . . . . .	4
<b>Table 4.</b>	Default STPMIC25A NVM configuration . . . . .	17
<b>Table 5.</b>	Operating modes . . . . .	20
<b>Table 6.</b>	PMIC turn-on conditions . . . . .	22
<b>Table 7.</b>	PMIC turn off conditions . . . . .	23
<b>Table 8.</b>	Low power mode supported by the application. . . . .	34
<b>Table 9.</b>	Power control signal connection. . . . .	34
<b>Table 10.</b>	PMIC configuration for LP-Stop1 mode. . . . .	38
<b>Table 11.</b>	PMIC configuration for LPLV-Stop1 mode . . . . .	41
<b>Table 12.</b>	PMIC configuration for LP-Stop2 . . . . .	45
<b>Table 13.</b>	PMIC configuration for LPLV-Stop2 . . . . .	48
<b>Table 14.</b>	PMIC configuration for standby DDR in self-refresh . . . . .	52
<b>Table 15.</b>	PMIC configuration standby DDR OFF . . . . .	56
<b>Table 16.</b>	OCP management application . . . . .	66
<b>Table 17.</b>	Document revision history . . . . .	67

**IMPORTANT NOTICE – READ CAREFULLY**

STMicroelectronics NV and its subsidiaries (“ST”) reserve the right to make changes, corrections, enhancements, modifications, and improvements to ST products and/or to this document at any time without notice.

In the event of any conflict between the provisions of this document and the provisions of any contractual arrangement in force between the purchasers and ST, the provisions of such contractual arrangement shall prevail.

The purchasers should obtain the latest relevant information on ST products before placing orders. ST products are sold pursuant to ST’s terms and conditions of sale in place at the time of order acknowledgment.

The purchasers are solely responsible for the choice, selection, and use of ST products and ST assumes no liability for application assistance or the design of the purchasers’ products.

No license, express or implied, to any intellectual property right is granted by ST herein.

Resale of ST products with provisions different from the information set forth herein shall void any warranty granted by ST for such product.

If the purchasers identify an ST product that meets their functional and performance requirements but that is not designated for the purchasers’ market segment, the purchasers shall contact ST for more information.

ST and the ST logo are trademarks of ST. For additional information about ST trademarks, refer to [www.st.com/trademarks](http://www.st.com/trademarks). All other product or service names are the property of their respective owners.

Information in this document supersedes and replaces information previously supplied in any prior versions of this document.

© 2026 STMicroelectronics – All rights reserved