

Using the VL53L3CX under ultralow-power mode

Introduction

This application note describes how to use the VL53L3CX sensor with an ultralow-power (ULP) driver, via the STSW-IMG033. This document describes how to:

- Achieve the lowest power consumption possible using the ULP driver
- Program the VL53L3CX sensor for ULP target detection

To achieve the lowest power consumption possible, the ULP driver effectively allows the VL53L3CX sensor to become a proximity detector. It does so using Time-of-Flight (ToF) technology. In such cases, the settings and ranging flows of the sensor are especially designed to reduce power consumption. For example, the current consumption is reduced down to 55 μA at 1 Hz ranging frequency, with a 2V8 power supply. All the processing is fully embedded into the sensor firmware. In addition, the sensor does not output traditional data such as distance, signal, and single-photon avalanche diode (SPAD) number. The implemented mechanism raises an interrupt to the host when a target is detected in the field of view (FoV).

Programming the sensor for ULP target detection is an additional feature. It is not part of the VL53L3CX standard bare driver (via the STSW-IMG015). This application note describes the main driver flow, the functions to program the device, and output results.

The VL53L3CX can also be configured in its traditional ranging mode using the standard bare driver. In this mode, the sensor is able to range up to 5 m using ST histogram algorithms. This allows cover glass crosstalk immunity beyond 80 cm and dynamic smudge compensation.

Both drivers (ULP and standard) can be used independently or together. When used together, the VL53L3CX acts as a low-power proximity detector, then it becomes an accurate ranging sensor when an interrupt is raised.

Applications

- Battery operated devices
- User detection
- System activation
- Touchless switch

Figure 1. VL53L3CX module



References:

- VL53L3CX datasheet (DS13204)
- VL53L3CX maximum ranging distance improvement (AN5561)

1 Acronyms and abbreviations

The main acronyms and abbreviations used in this document are listed below.

Table 1. Acronyms and abbreviations

Acronym/abbreviation	Definition
cps	Count per second
FoV	field of view
HW	hardware
IR	Infrared
MCU	microcontroller unit
refspad	calibration for ranging
ROI	region of interest
SPAD	Single photon avalanche diode
ToF	Time-of-Flight
ULD	ultralite driver
ULP	ultralow-power

2 Functional description

2.1 System overview

The VL53L3CX system is composed of a hardware module and the ultralite driver software. The system is dedicated for ultralow-power use on a host (see figure below). The hardware module contains the ToF sensor. ST delivers the software driver, which is referred to in this document as "the driver". This document describes the functions of the driver, which are accessible to the host. These functions allow the user to control the sensor, change the settings, and start/stop measurements.

Figure 2. VL53L3CX ultralow-power system overview

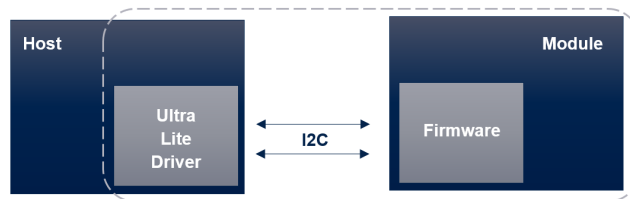

2.2 Schematics and I2C configuration

Communication between the driver and firmware is handled by the I2C. The I2C can operate up to 1 MHz. Implementation requires pull-ups on the SCL and SDA lines. Refer to the VL53L3CX datasheet for more information.

The VL53L3CX device has a default I2C address of 0x52. However, it is possible to change the default address to avoid conflict with other devices. It is also possible to add multiple VL53L3CX modules to the system for an improved system FoV. The I2C address can be reprogrammed using the function `VL53L3CX_ULP_SetI2CAddress()`.

The host hardware must allow the sensor's XSHUT pins to be controlled individually. Each XSHUT pin must be connected to a GPIO pin on the host microcontroller unit (MCU).

To change the I2C address, the host must:

1. Put the device in HW standby by setting the XSHUT pin low on all VL53L3CX devices
2. Raise the XSHUT pin of one of the VL53L3CX devices (example, `current_tof`)
3. Call `VL53L3CX_ULP_SetI2CAddress(current_tof, newAddress)` to program the new address
4. Repeat the steps from [2 to 3] to change the address of all ToFs.

Figure 3. Multiple sensors on the I2C bus shows the required connection to have multiple sensors on a single I2C bus. For the schematics, refer to the VL53L3CX datasheet.

Figure 3. Multiple sensors on the I2C bus

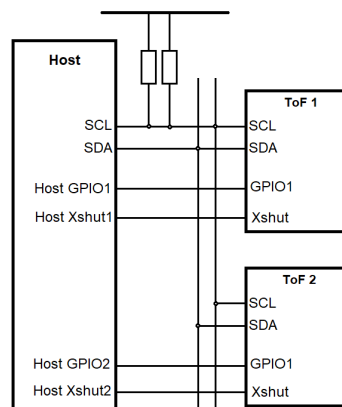

3 Driver architecture and content

3.1 Driver architecture and content

The VL53L3CX ULP package is composed of four folders. They are shown in [Figure 4. Driver architecture](#).

Figure 4. Driver architecture

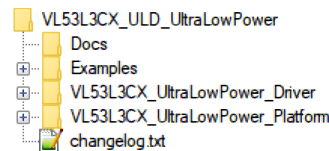

The user needs to implement two files, which are located in the /VL53L3CX_UltraLowPower_Platform folder. The proposed platform is an empty dummy. It must be filled with dedicated functions.

3.2 Compatibility with VL53L3CX bare driver

The ULP driver is compatible with the standard bare driver. The former is used to configure the VL53L3CX as a proximity detector. The latter enables the VL53L3CX as a full-feature ranging sensor. A dedicated example showing the usage of both drivers is available in the ULP delivery folder.

3.3 Calibrations

The VL53L3CX ULP driver does not require calibration. The refspad and offset data are automatically calibrated in ST factories. They are then stored in the VL53L3CX module.

When a cover glass is used, the detection distance may be affected when the target is far from the sensor. For example, a target located at 800 mm from the sensor may be detected by the algorithm at 750 mm. This effect is particularly visible using small macroperiods (see [Section 4.3 Macroperiod](#)).

If the user wants to filter these measurements, ST recommends:

- Increasing the signal threshold, and
- Reducing the sigma threshold

This improves the accuracy of the system. The direct effect of this tuning is a reduction of the maximum detection distance. The value of this tuning depends on the cover glass quality and the application. More information is available in [Section 4.4 Sigma and signal thresholds](#).

3.4 Ranging flow

Figure 5. Ranging flow

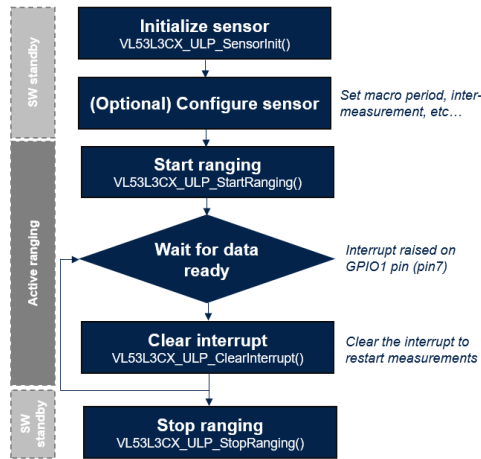

4 Available features

The VL53L3CX ULP driver contains several functions used to program and tune the sensor. All the functions available in the driver are described in the sections below.

4.1 Initialization

An "initialization" step is required to use the device and driver together. Initialization performs a boot routine, and prepares the sensor for use with the driver. It involves powering on the sensor and calling the function `VL53L3CX_ULP_SensorInit()`. A typical initialization time is 25 ms.

4.2 Intermeasurement period

The intermeasurement period allows the time between two consecutive measurements to be defined. The value can be programmed between 20 ms and 60000 ms. The default value is 1000 ms. A lower intermeasurement period allows a reduction of the power consumption, but it also reduces the framerate.

4.3 Macroperiod

The macroperiod is a value proportional to the integration time. It corresponds to the total time during which the VCSEL is pulsing. A high macroperiod allows the maximum detection distance to be increased, but it also increases the power consumption. Evolution of performances over the macroperiod is described in [Section 5 Current consumption performances](#).

The macroperiod value can be changed using the function `VL53L3CX_ULP_SetMacroPeriod()`. The value can be programmed between 1 and 255. The default value is 1.

4.4 Sigma and signal thresholds

Two thresholds (sigma and signal) can be used to monitor if a target is valid.

The sigma threshold corresponds with the standard deviation of the returned pulse. It is used to flag a target detection as valid or invalid. If the computed sigma is above the programmed value, the range status returns an error of 1 instead of a valid value of 0. The value can be changed using the function `VL53L3CX_ULP_SetSigmaThreshold()`. The default value is 45 mm, the minimum value is 1 mm, and the maximum value is 16383 mm.

The signal threshold corresponds with the minimum number of photons reflected by the target back to the sensor, which considers a valid detection. It is used to flag a target detection as valid or invalid. If the computed signal is below the programmed value, the range status returns an error of 2 instead of a valid value of 0. The value can be changed using the function `VL53L3CX_ULP_SetSignalThreshold()`. The default value is 1500 kcps, the minimum value is 1 kcps, and the maximum value is 16383 kcps.

Using a low sigma and high signal threshold allows the maximum power consumption to be saved. This avoids detecting false targets (false positives) which are actually not before the sensor. Unfortunately, a low sigma and high signal threshold also reduces the maximum ranging distance. The benefits of low sigma and high signal thresholds are shown in [Table 2. Sigma and signal threshold effects](#). Examples of thresholds and results are given in [Table 5. Maximum ranging capabilities for 90% detection rate at 0 klux \(dark\)](#) and [Table 6. Maximum ranging capabilities for 90% detection rate at 5 klux \(ambient light\)](#)

Table 2. Sigma and signal threshold effects

Threshold	Action	Effect on power consumption and false-positives	Effect on maximum ranging distance
Sigma	Increase threshold	—	+
	Decrease threshold	+	—
Signal	Increase threshold	+	—
	Decrease threshold	—	+

4.5 Region of interest (ROI)

The ROI function allows some of the SPADs to be disabled. A high SPAD number allows the maximum ranging distance to be increased, but it also increases power consumption. Changing the SPAD number has no effect on the field of view (FoV).

ST recommends changing the number of SPADs only if the user wants to reach a current consumption below 75 μA . Using the minimum ROI, the current consumption during ranging is typically reduced by -10 μA . The impact on maximum ranging distance depends on the reflectance, ambient light, and macroperiod. In some conditions, using the minimum ROI can reduce the maximum ranging distance by -50%. Some measurement examples are given in [Section 6 Ranging performances](#).

The ROI can be changed using the function `VL53L3CX_ULP_SetROI()`. The minimum value is 4x4, and the maximum value is 16x16. By default, the sensor is programmed in 16x16 mode.

4.6 Interrupt configuration

This dedicated function allows the hardware interrupt on the GPIO1 (pin 7) to be configured. An interrupt is raised which indicates that a new measurement is ready, or that a user is detected within the FoV.

This configuration can be changed using the function `VL53L3CX_ULP_SetInterruptConfiguration()`. There are two possible configurations:

- The interrupt is raised when a new measurement is ready. The period of returned measurements is equal to the intermeasurement period. The interrupt is raised even if the measurement is invalid (when there is no target detection). This option is particularly useful to get debug data, and to tune the sigma/signal thresholds. This is the default driver mode.
- The interrupt raised only when a target is detected (the measurement is valid). The user needs to define a detection distance threshold in millimeters. This option is useful in real world applications, to raise interrupts only when a valid target is detected.

4.7 Debug data for tuning

This feature gets the debug data that contain the internal sensor data. Consequently, it helps the sigma and signal tuning. After clearing the interrupt, the user can call this function `VL53L3CX_ULP_DumpDebugData()`. It extracts the estimated distance, the signal rate, the sigma, the number of SPADs, and the range status. A target is considered as valid if the status is equal to 0.

4.8 Temperature update

Ambient temperature affects ranging. For the sensor to be at its best, ST recommends reinitializing it when the temperature may have changed by more than 8° Celsius. This is done by calling the `VL53L3CX_ULP_SensorInit()` function.

5 Current consumption performances

5.1 Device in standby mode

When the device is in standby mode, the current consumption is the same as stated in the VL53L3CX datasheet (see Table 3. Current consumption when the device is in standby mode).

Table 3. Current consumption when the device is in standby mode

Parameter	Min.	Typ.	Max.	Unit
HW STANDBY	3	5	7	μA
SW STANDBY (2V8)	4	6	9	μA

5.2 Device in ranging mode

When the device is ranging, three main factors can be tuned to reduce the current consumption. They are:

- Intermeasurement period
- Macroperiod 1 to 255
- ROI (4x4 or 16x16)

A full description of these settings is available in [Section 4 Available features](#).

For a fixed intermeasurement period, the user can play on the macroperiod and the ROI. These two settings have a direct impact on the current consumption, but also on the maximum detection distance that can be reached.

The evolution of the current consumption over a macroperiod with a 1000 ms intermeasurement period, in full ROI mode is given in [Figure 6. Typical current consumption over macroperiod for a typical module](#).

Figure 6. Typical current consumption over macroperiod for a typical module

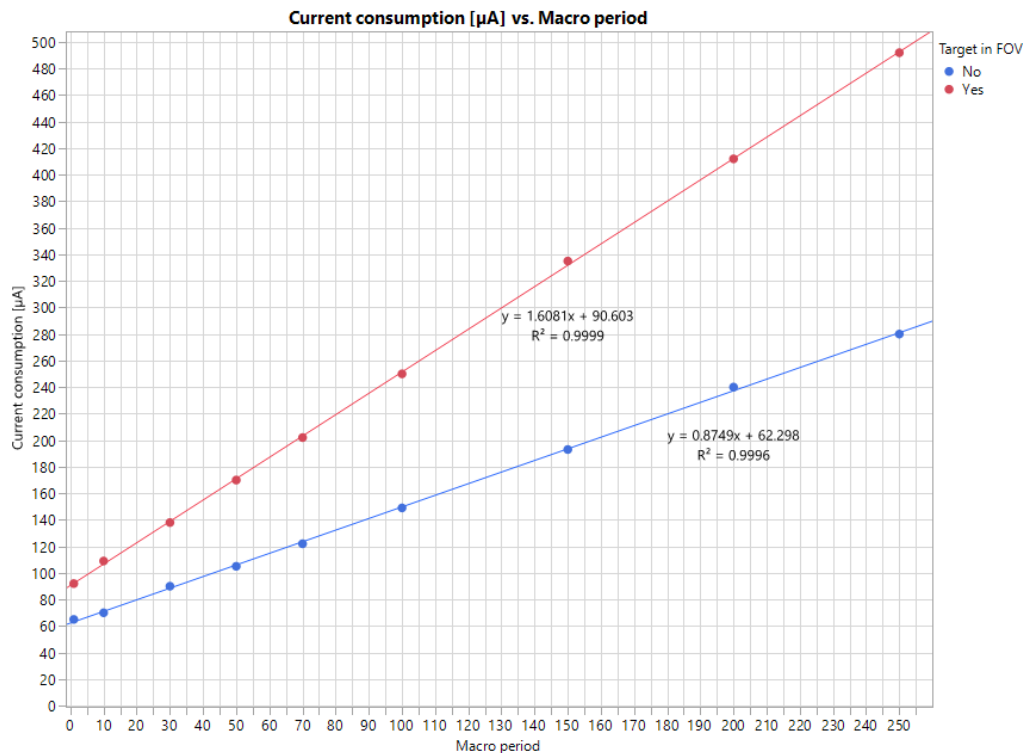

Note: Current consumption is given for the sum of AVDD + AVDDVCSEL at 2V8.

Note: Using the minimum ROI, current consumption is typically reduced by -10 μA.

Coefficients of each graph are given in the table below.

Table 4. Coefficients of current consumption equations

Case	Gain	Offset
No target in FoV	0.8749	62.298
Target in FoV	1.6081	90.503

5.3 Estimation of current consumption

For a known configuration, the current consumption can be estimated using [Figure 6. Typical current consumption over macroperiod for a typical module](#). Such estimation is provided to support customer evaluation and integration. It does not replace real measurements.

In 2V8 power supply, the current consumption can be estimated using the formulas below.

- If no target is detected: $Current [\mu A] = \frac{1000}{Intermeasurement [ms]} \times (0.8749 \times macroperiod + 62.298 - 7)$
(1)
- If a target is detected: $Current [\mu A] = \frac{1000}{Intermeasurement [ms]} \times (1.6081 \times macroperiod + 90.503 - 14)$
(1)

1. This factor needs to be applied only if the smallest ROI is selected (4x4). Otherwise, it can be removed.

These equations are approximations with a typical error of $\pm 8\%$ over the real current consumption.

6 Ranging performances

6.1 Measurement conditions

In all the measurement tables of this document, it is considered that:

1. All ranging performances are measured with the target covering the full FoV.
2. Charts used as targets are:
 - a. gray 17% reflectance (N4.74 Munsell)
 - b. gray 54% reflectance (N8.25 Munsell)
 - c. white 88% reflectance (N9.5 Munsell)
3. Nominal voltage is 2.8 V and temperature is 23°C.
4. Typical samples are used.
5. The device is controlled through the driver using the default settings.
6. Indoor (no IR) means that there is no light contribution in the band 940 nm \pm 30 nm.
7. Outdoor overcast corresponds to an ambient light level of 10 kcps/SPAD for the VL53L3CX module. For reference, this corresponds to a 1.2 W/m² at 940 nm following the AM 1.5G spectrum. This is equivalent to five kLux daylight as reflected by a gray 17% chart at 40 cm.
8. No cover glass is present.
9. Performances are given for 90% detection rate. Detection rate is a statistical value indicating the worst percentage of measurements that return a valid ranging. For example, taking 1000 measurements with 90% detection rate gives 900 valid distances. The 100 other distances may be outside the specification, or flagged with an invalid status.

6.2 Minimum ranging distance

The minimum ranging distance to detect a target is 10 mm.

6.3 Maximum ranging distance in dark conditions

Table 5. Maximum ranging capabilities for 90% detection rate at 0 klux (dark)

Configuration	Typical current consumption	Max. distance, gray 17%	Max. distance, gray 54%	Max. distance, white 88%
Minimum ROI Macro period 1 Signal limit 1500 Sigma limit 40	No target: 55 μ A Target: 80 μ A	>100 mm	>190 mm	>230 mm
Full ROI Macro period 1 Signal limit 6000 Sigma limit 35	No target: 65 μ A Target: 90 μ A	>170 mm	>330 mm	>420 mm
Full ROI Macro period 30 Signal limit 1600 Sigma limit 45	No target: 90 μ A Target: 140 μ A	>290 mm	>640 mm	>760 mm
Full ROI Macro period 100 Signal limit 1600 Sigma limit 60	No target: 150 μ A Target: 250 μ A	>300 mm	>650 mm	>800 mm
Full ROI Macro period 200 Signal limit 1500 Sigma limit 60	No target: 240 μ A Target: 410 μ A	>310 mm	>680 mm	>840 mm

6.4 Maximum ranging distance under ambient light

Table 6. Maximum ranging capabilities for 90% detection rate at 5 klux (ambient light)

Configuration	Typical current consumption	Max. distance, gray 17%	Max. distance, gray 54%	Max. distance, white 88%
Minimum ROI Macro period 1 Signal limit 1500 Sigma limit 40	No target: 75 μ A Target: 100 μ A	Configuration not reliable. Many false-positives.	Configuration not reliable. Many false-positives.	Configuration not reliable. Many false-positives.
Full ROI Macro period 1 Signal limit 6000 Sigma limit 35	No target: 85 μ A Target: 110 μ A	>45 mm	>45 mm	>50 mm
Full ROI Macro period 30 Signal limit 1600 Sigma limit 45	No target: 110 μ A Target: 160 μ A	>180 mm	>180 mm	>190 mm
Full ROI Macro period 100 Signal limit 1600 Sigma limit 60	No target: 170 μ A Target: 270 μ A	>240 mm	>260 mm	>270 mm
Full ROI Macro period 200 Signal limit 1500 Sigma limit 60	No target: 260 μ A Target: 430 μ A	>270 mm	>290 mm	>300 mm

Revision history

Table 7. Document revision history

Date	Version	Changes
15-Feb-2022	1	Initial release
05-May-2022	2	Correct the error numbers stated in Section 4.4 Sigma and signal thresholds

Contents

1	Acronyms and abbreviations	2
2	Functional description	3
2.1	System overview	3
2.2	Schematics and I2C configuration	3
3	Driver architecture and content	4
3.1	Driver architecture and content	4
3.2	Compatibility with VL53L3CX bare driver	4
3.3	Calibrations	4
3.4	Ranging flow	5
4	Available features	6
4.1	Initialization	6
4.2	Intermeasurement period	6
4.3	Macroperiod	6
4.4	Sigma and signal thresholds	6
4.5	Region of interest (ROI)	7
4.6	Interrupt configuration	7
4.7	Debug data for tuning	7
4.8	Temperature update	7
5	Current consumption performances	8
5.1	Device in standby mode	8
5.2	Device in ranging mode	8
5.3	Estimation of current consumption	9
6	Ranging performances	10
6.1	Measurement conditions	10
6.2	Minimum ranging distance	10
6.3	Maximum ranging distance in dark conditions	11
6.4	Maximum ranging distance under ambient light	12
	Revision history	13
	Contents	14

IMPORTANT NOTICE – READ CAREFULLY

STMicroelectronics NV and its subsidiaries (“ST”) reserve the right to make changes, corrections, enhancements, modifications, and improvements to ST products and/or to this document at any time without notice. Purchasers should obtain the latest relevant information on ST products before placing orders. ST products are sold pursuant to ST’s terms and conditions of sale in place at the time of order acknowledgment.

Purchasers are solely responsible for the choice, selection, and use of ST products and ST assumes no liability for application assistance or the design of purchasers’ products.

No license, express or implied, to any intellectual property right is granted by ST herein.

Resale of ST products with provisions different from the information set forth herein shall void any warranty granted by ST for such product.

ST and the ST logo are trademarks of ST. For additional information about ST trademarks, refer to www.st.com/trademarks. All other product or service names are the property of their respective owners.

Information in this document supersedes and replaces information previously supplied in any prior versions of this document.

© 2022 STMicroelectronics – All rights reserved