Guidelines for the cover glass of the VL53L8 Time-of-Flight (ToF) multizone sensor family

Introduction

The aim of this application note is to provide guidelines for industrial design and how to assess cover glass quality. It details STMicroelectronics' recommendations on cover glass selection and design requirements for minimizing the crosstalk and optimizing the system.

This application note covers all multizone sensors of the VL53L8 family, whatever the suffix (example: VL53L8CX and VL53L8CH).

Figure 1. VL53L8 ranging sensor module



1 Acronyms and abbreviations

Table 1. Acronyms and abbreviations

Acronym/abbreviation	Definition
AFC	antifingerprint coating
ARC	antireflective coating
cps	photon count per second
FoV	field of view
FWHM	full width at half maximum
IR	infrared
PMMA	poly methyl methacrylate
Rx	receiver
SPAD	single photon avalanche diode
ToF	Time-of-Flight
Tx	transmitter
VCSEL	vertical-cavity surface-emitting laser

2 General information

The cover glass is normally an opaque window with a coating layer that presents apertures to allow the emission and reception of IR light. The apertures can be either one oval aperture or two circular apertures. Often cover glasses are coated with filter film that is generally deposited on the underside of the window.

The cover glass serves two main purposes:

- Physical protection of the device, including dust ingress prevention
- Optical filtering

The cover glass may also be used for aesthetic purposes. For this reason, on the coating layer, it is possible to create two equal-sized holes, placed on the top of the transmitter and the receiver. However, the receiver hole can be made smaller if required (see [Section 5 Cover glass mechanical guidelines](#) for more details).

The [Figure 2. Crosstalk critical paths](#) presents the VL53L8 system in a typical application. The cover glass is placed on the top of the module and a space is left between the two. This space is generally called the air gap and is measured in mm.

Experimental data shows that increasing the air gap size leads to an increase of:

- Crosstalk signal
- Signal loss

2.1 System crosstalk

The VL53L8 family sensors are devices with a wide FoV that allows high signal reception coming from the target. At the same time, a crosstalk signal is present in the receiver array.

The crosstalk is defined as light coming from the module emitter and not reflected by the target, but that follows alternative, undesirable paths to reach the receiver. For this reason, the crosstalk signal does not bring any useful information from the target (such as distance and reflectance), and must be minimized.

The crosstalk optical path is short, so the crosstalk pulse appears close to zero distance/delay. The amount of crosstalk depends on the optical setup, cover glass geometry, and properties. Crosstalk can also vary during the life of the product due to scratches or dirt on the cover glass.

Figure 2. Crosstalk critical paths

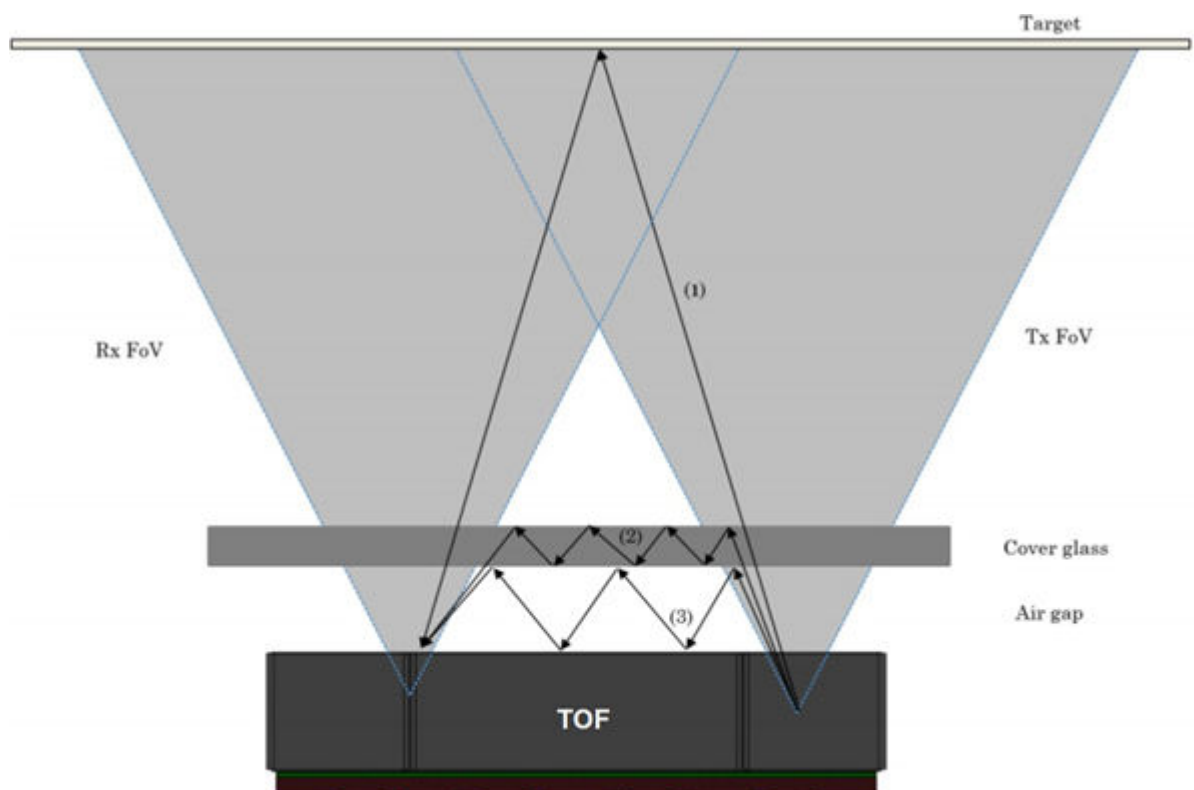

The figure above highlights the typical optical paths that the light, shot by the emitter, may follow before reaching the receiver array.

The main paths represented are:

- Target signal path, marked as (1) in the figure above
- The crosstalk signal path inside the cover glass, marked as (2) in the figure above
- The crosstalk signal path inside the air gap, marked as (3) in the figure above

The aim of the final application design is to minimize the crosstalk signals and maximize the target signal avoiding any obstacles or attenuation along its path.

In general, the crosstalk signal increases with the thickness of the cover glass. To minimize the crosstalk signal, it is recommended to use the thinnest cover glass choice available. To break the crosstalk path propagating through the cover glass, it is recommended to use a light-blocker as shown in the figure below.

The crosstalk signal decreases when the air gap size is reduced, see [Section 7 Conclusion and summary table](#) for more details. Therefore, it is recommended to have the smallest air gap possible.

To break the crosstalk path propagating through the air gap, it is recommended to use a gasket. Specific dark material like neoprene can be placed in the middle of the air gap space to break the crosstalk light path (Yoder, P.R., *Opto-Mechanical Systems Design, 3rd Ed.*, CRC Press, 2006 and Harris, D.C., *Materials for Infrared glass and Domes, Properties and Performance*, SPIE Press, Bellingham, 1999).

For air gaps >0.7 mm, a gasket is recommended to ensure that the crosstalk signal level is kept below the maximum recommended limit of 300 kcps/SPAD.

The crosstalk effect has several negative impacts, such as an increase in:

- Signal loss
- Ranging nonlinearity
- Ranging standard deviation

Moreover, the crosstalk signal is temperature dependent as well as the target signal. In general, the crosstalk signal increases with the temperature rise.

Figure 3. Final application configuration with a VL53L8 module

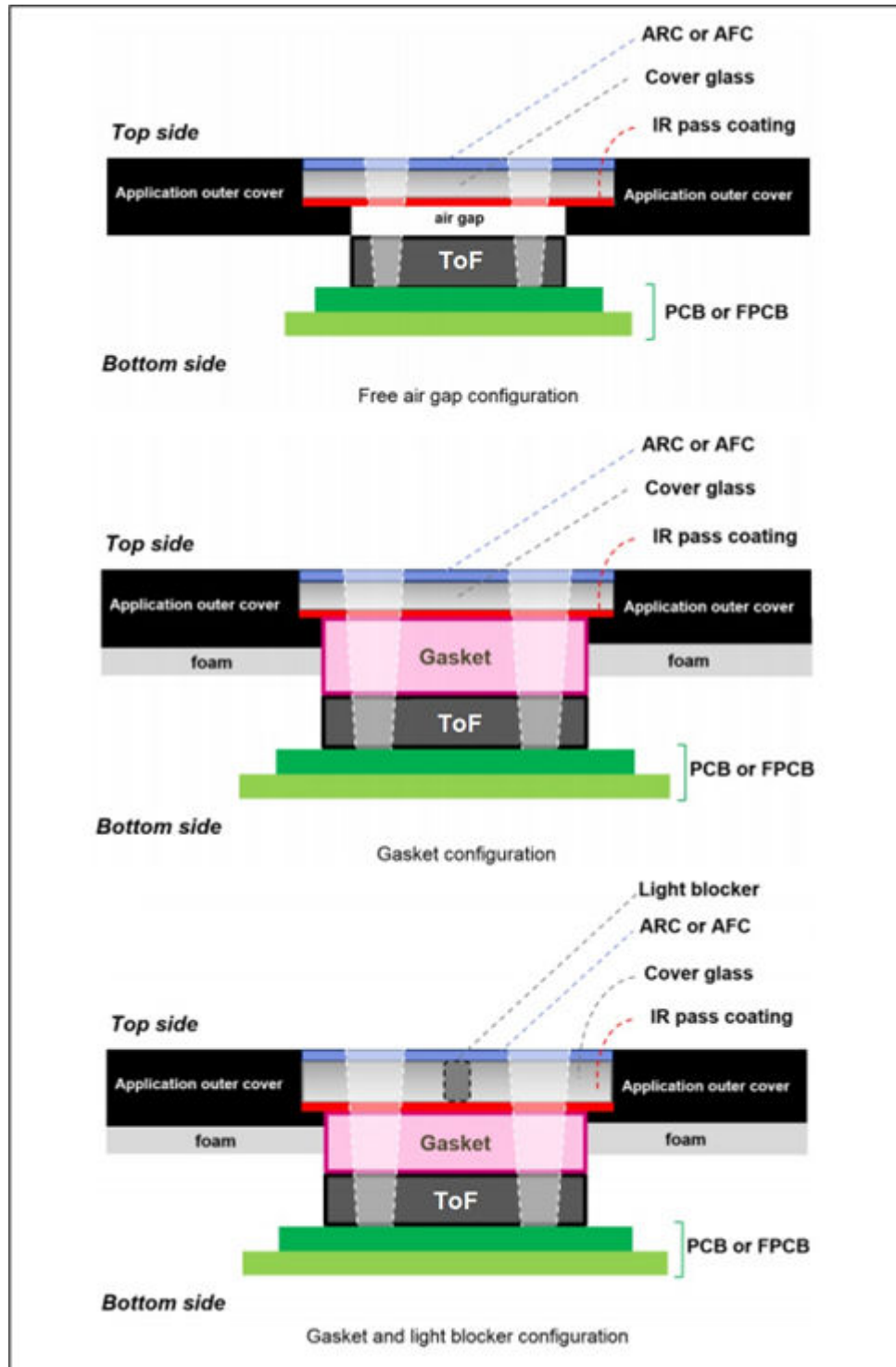

3 Crosstalk immunity of the VL53L8 sensors

To benefit from the device's full performance, the VL53L8 driver includes a calibration function dedicated to crosstalk compensation. The crosstalk calibration must be run once at the customer production line. This calibration procedure must be run to compensate the part-to-part cover glass spread that may affect device performances. Calibration data stored in the host must be loaded into the VL53L8 module at each startup to apply the crosstalk compensation to the measurements acquired. Calibration data can only be loaded onto the VL53L8 module by using the dedicated driver function.

4 Cover glass design

The crosstalk signal is very sensitive to the cover glass design and structure. The manufacturing properties of the cover glass affect the light scattering phenomena and consequently the crosstalk as shown in the figure below.

For instance, particles and crystal defects embedded inside the cover glass increase light scattering. Similarly, the cover glass surface topography and the surface roughness affect crosstalk.

In order to avoid the light scattering effect and reduce the crosstalk signal, the cover glass should be manufactured to have:

- No defects in the crystal structure or on the top of the surface layer
- No impurities or dislocation inside the structure
- No smudge or superficial artifacts

Figure 4. Light scattering examples due to internal defects or superficial roughness

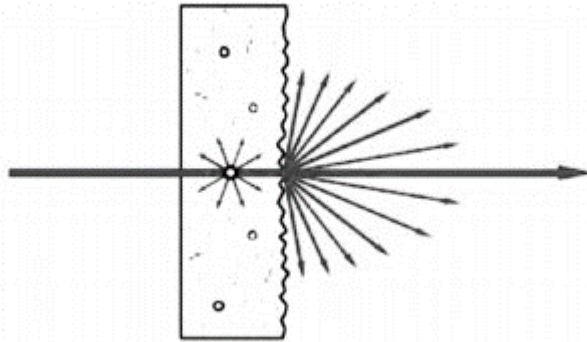

4.1 Optical transmission

From the optical point of view, the cover glass must allow transmission of IR light emitted by the module VCSEL at 940 nm with 1.6 nm at full width at half maximum (FWHM), and received by the SPAD array embedded inside the module. It is required to have the optical transmission of the cover glass higher than 87% in this bandwidth.

The table below shows the estimated evolution of maximum ranging distance over the transmittance.

Table 2. Evolution of maximum ranging distance

Example of 8x8 mode, dark conditions, white 88% target reflectance, 15 Hz ranging frequency, with default driver settings.

Transmittance [%]	Estimated maximum ranging distance [mm]
100	4000 mm
90	3800 mm
80	3600 mm
70	3400 mm
50	3000 mm
20	2400 mm

Note: *All the signals not transmitted by the cover glass are lost or can potentially turn into crosstalk. Loss of signal directly affects the performance of the VL53L8 module, and the maximum ranging distance. It is recommended to have the highest cover glass transmittance possible.*

4.2 Cover glass coating

The cover glasses are normally coated with different material for different purposes.

- Colored ink for aesthetic reasons
- IR filter to cut off all the unwanted light in the IR transmission. Normally the filter coating is deposited on the back side of the window.
- ARC: antireflective coating to reduce the surface reflectance.
- AFC: antifingerprint coating to increase the fingerprint protection.

It is important to note that superficial coating may generate additional crosstalk signals. In fact, any transmissive layer deposited on the cover glass could act as an optical path to guide the crosstalk light from the emitter to the receiver.

Note: Whenever possible, avoid the use of any cover glass coating, at least in the exclusion areas defined in [Section 5 Cover glass mechanical guidelines](#). It is recommended to use outer coatings that do not degrade the immunity to the fingerprint (for example, antifingerprint or antireflective coatings with the antifingerprint feature) in order to reduce a smudge effect or loss of signal.

4.3 Haze

Haze is defined as the percentage of light that, when passing through a certain material, deviates from the incident beam, on average, by an angle greater than 2.5 degrees.

The crosstalk signal does experimentally increase with the square of the haze percentile. It is recommended to have haze less than 2% of the total light emitted (1%, 940 nm IR).

Figure 5. Representation of light haze

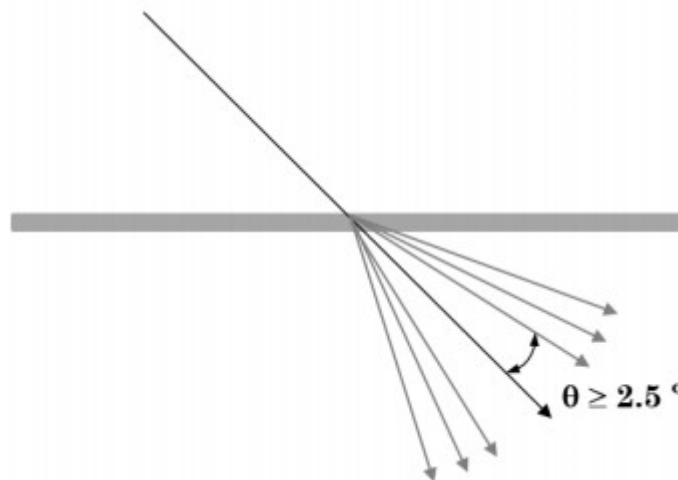

4.4 Cover glass tilt and surface parallelism

The cover glass top and bottom surfaces must both be parallel to the device surface. Ideally, any cover glass tilt must be avoided to reduce the crosstalk signals.

If mechanical constraints require to tilt the device, the user must ensure that the maximum crosstalk is below 300 kcps/SPAD. The recommended maximum tilt is given in [Table 5. Cover glass guidelines and summary table](#).

4.5 Cover glass materials

Single material is recommended for the cover glass design. Multi-materials may alter the performance or increase the internal light scattering effect. Materials suggested are:

- Glass
- Sapphire glass
- Poly methyl methacrylate (PMMA)
- Polycarbonate

5 Cover glass mechanical guidelines

This section provides information on the VL53L8 module geometrical dimensions necessary to calculate the minimal aperture dimensions of the cover glass coating layer. See the figure below.

- The receiver mechanical aperture is circular with diameter 0.51 mm (area 0.4086 mm²).
- The emitter mechanical aperture is rectangular with a width of 0.74 mm and high 0.90 mm (area 0.666 mm²).
- The distance between the optical emitter center and the optical receiver center is 4 mm as reported in the figure below.
- It is optional to have one large cover glass aperture or two separate apertures. The final decision is partly aesthetic, partly functional. Two apertures may offer better crosstalk immunity, particularly in designs with no gasket.

Figure 6. VL53L8 mechanical dimensions

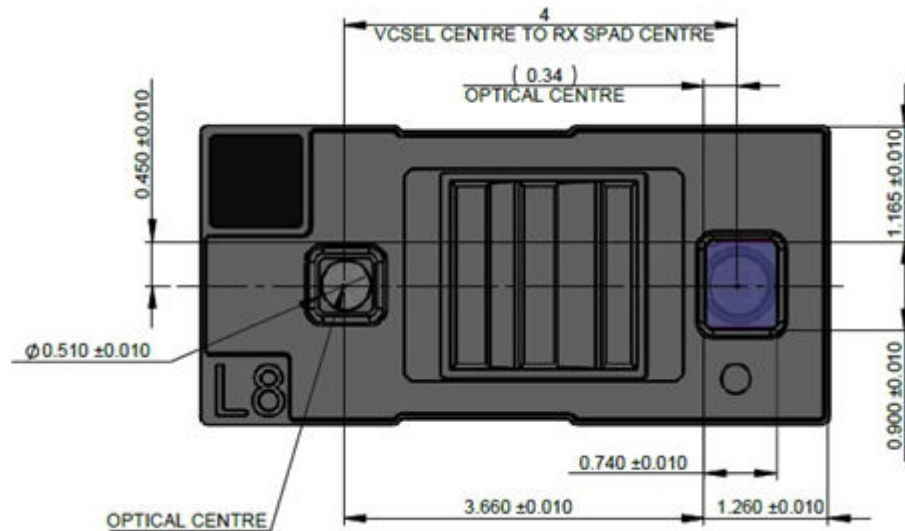

Note: *It is important to align the apertures with the optical centers of the VCSEL, as above. They are not the same as the mechanical centers. Further mechanical details can be found in the datasheet.*

To design the final dimensions, it is initially assumed to have rectangular apertures with sizes here named aR, bR on the receiver side, and aT, bT on the transmitter side. The diagonals of these rectangles represent the diameters, here named dR and dT, of the circular apertures that are created in the cover glass coating. The cover glass coating apertures are aligned with the module apertures concentrically (see the figure below).

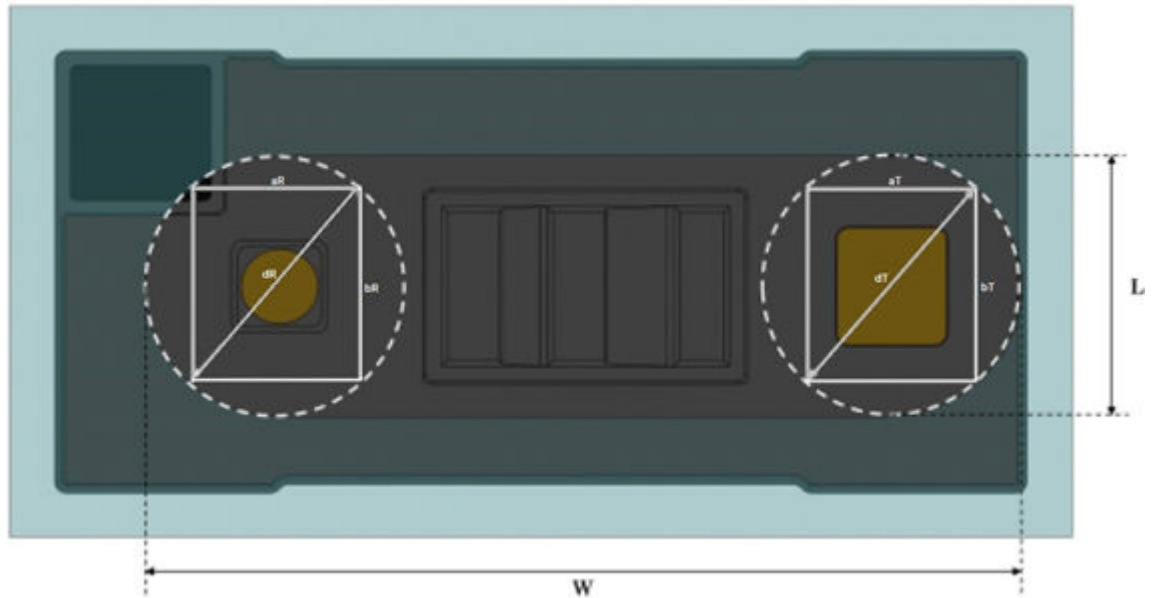
Figure 7. Example of cover glass coating with single aperture

Knowing the collector exclusion cone of the VL53L8 module, 57.9° along the x and y direction (for more details refer to the VL53L8 module outline drawing), it is possible to calculate the minimum apertures of the cover glass using the following formulae. See the figure below as reference for the calculation.

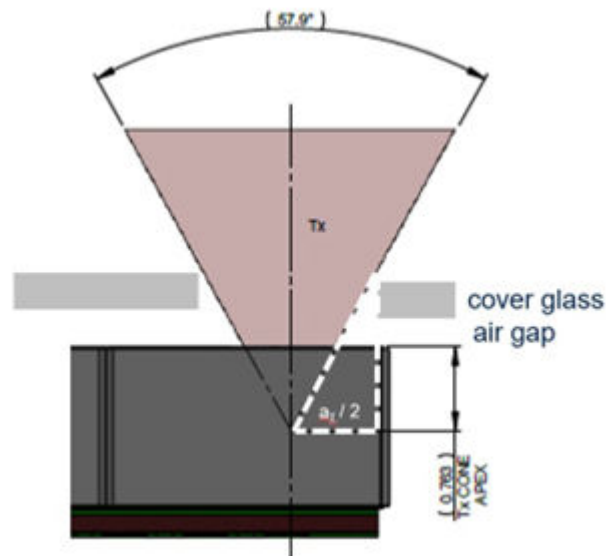
Figure 8. Cover glass Tx aperture

a_T , corresponding to the 57.9° collector exclusion cone, can be calculated with the following formula.

$$a_T = 2 \times [T_{xPyramidApex} + h_{ag} + h_{ac}] \times \tan\left(\frac{57.9^\circ}{2}\right)$$

As the keepout cone is defined as square $a_T = b_T$

The diameter of the circumscribed circle that covers the rectangular aperture in the cover glass can be calculated as:

$$d_T = \sqrt{a^2 + b^2}$$

Similar formulae can be written for the Rx side with the same dimension but a $RxPyramidApex = 0.736$

When using a cover glass with a single aperture (see Figure 7. Example of cover glass coating with single aperture), the two dimensions of the aperture are called W (width) and L (length).

Adding a tolerance of $t = 200 \mu\text{m}$ on each side of the module, it is possible to calculate W as follows.

$$W = 2 \cdot t + \frac{d_T}{2} + 4 + \frac{d_R}{2}$$

Using d_T , because it is bigger than d_R , it is possible to calculate L with the following formula.

$$L = 2 \cdot t + d_T$$

The following table reports all the results calculated using the different air gap dimensions given in the first column.

Table 3. Cover glass dimension calculation

air gap	a_T	b_T	d_T	a_R	b_R	d_R	W	L
0	1.3973	1.3973	1.9761	1.3674	1.3674	1.9338	6.3550	2.3761
0.15	1.5633	1.5633	2.2108	1.5334	1.5334	2.1685	6.5897	2.6108
0.2	1.6186	1.6186	2.2890	1.5887	1.5887	2.2468	6.6679	2.6890
0.3	1.7292	1.7292	2.4455	1.6993	1.6993	2.4032	6.8243	2.8455
0.4	1.8398	1.8398	2.6019	1.8100	1.8100	2.5597	6.9808	3.0019
0.5	1.9505	1.9505	2.7584	1.9206	1.9206	2.7161	7.1373	3.1584
0.8	2.2824	2.2824	3.2278	2.2525	2.2525	3.1855	7.6066	3.6278
1	2.5036	2.5036	3.5407	2.4738	2.4738	3.4984	7.9196	3.9407

Note:

Dimensions assume a cover glass thickness of 0.5 mm and the stated dimension is on the top side of the glass. This calculation includes 2° of angular tolerance ($\theta_{\text{tolerance}}$) in addition to the collector exclusion cone (see figure below), then the calculation results are reported in Table 4. Cover glass calculation with 2° tolerance.

Figure 9. Cover glass Tx aperture with angle tolerance in x direction

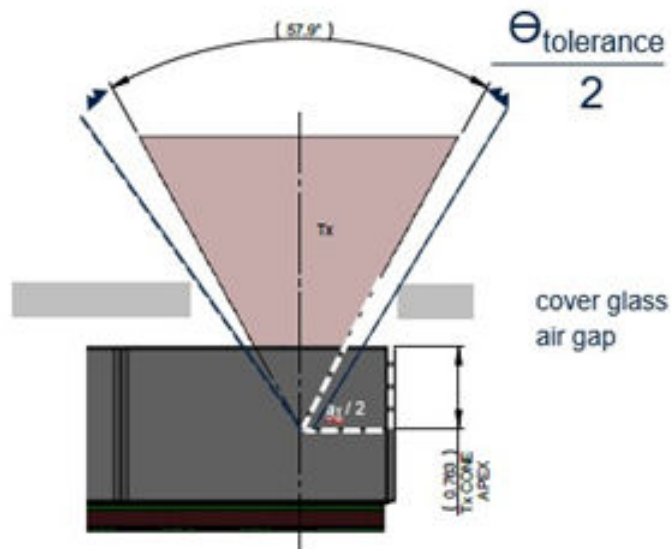
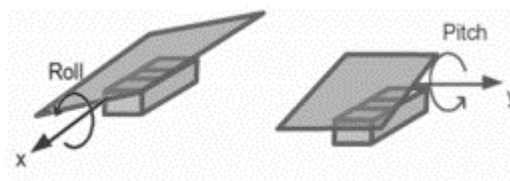

Table 4. Cover glass calculation with 2° tolerance

air gap	a_T	b_T	d_T	a_R	b_R	d_R	W	L
0	1.4554	1.4554	2.0583	1.4243	2.0143	6.4363	2.4583	1.4554
0.15	1.6283	1.6283	2.3028	1.5972	2.2588	6.6808	2.7028	1.6283
0.2	1.6859	1.6859	2.3843	1.6548	2.3403	6.7623	2.7843	1.6859
0.3	1.8012	1.8012	2.5472	1.7700	2.5032	6.9252	2.9472	1.8012
0.4	1.9164	1.9164	2.7102	1.8853	2.6662	7.0882	3.1102	1.9164
0.5	2.0316	2.0316	2.8732	2.0005	2.8292	7.2512	3.2732	2.0316
0.8	2.3773	2.3773	3.3621	2.3462	3.3181	7.7401	3.7621	2.3773
1.0	2.6078	2.6078	3.6880	2.5767	3.6440	8.0660	4.0880	2.6078

Note: Dimensions assume a cover glass thickness of 0.5 mm and the stated dimension is on the top side of the glass. If the cover glass is not parallel to the VL53L8 module surface, then some pitch or roll may occur as shown in the figure below.

Figure 10. Cover glass pitch or roll rotation

In case of pitch and roll rotation of the cover glass, the size and shape of the apertures change as shown below and must be recalculated.

The calculation can be provided in a separate document if required. Contact your ST customer support office for more information.

Figure 11. Aperture shapes with cover glass rotation

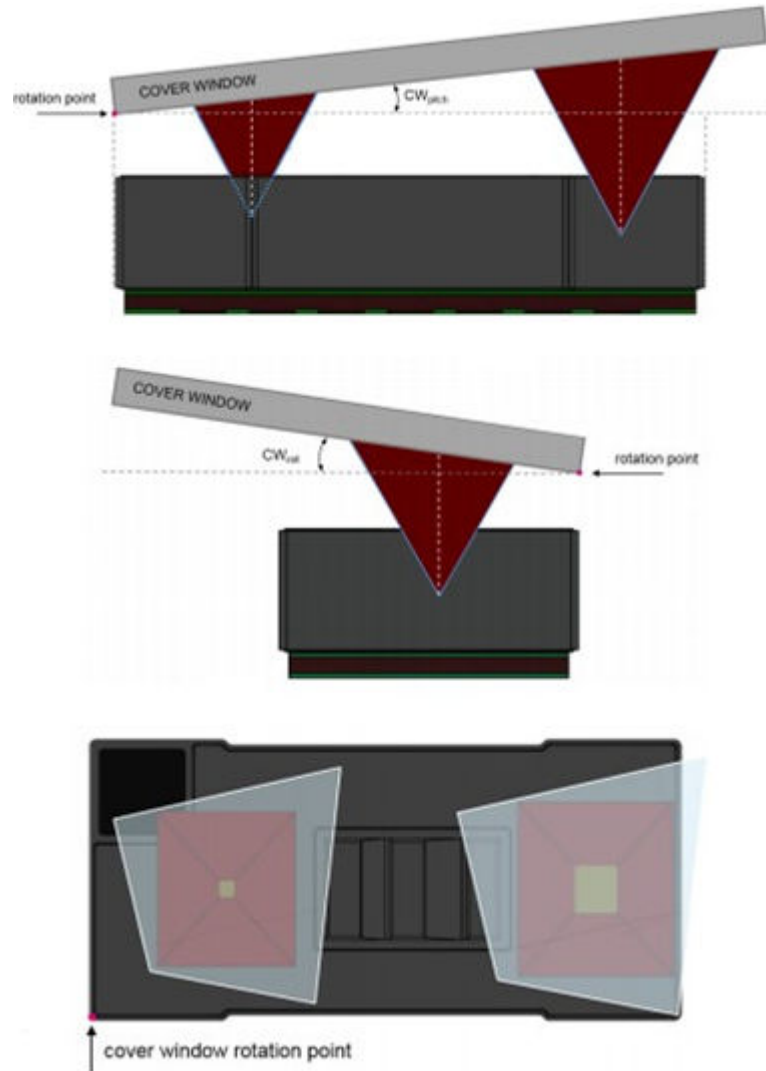

6 Crosstalk compensation

Crosstalk compensation is a feature embedded in the VL53L8 firmware. It allows compensation of the crosstalk effect, based on characterization results and calibration data. The procedure for crosstalk characterization is detailed in the product's user manual.

In general, the lower the crosstalk, the easier it is to compensate. Additionally, the less variation in crosstalk due to smudge or haze, the easier it is to compensate in the field.

A cover glass with poor quality design or manufacture increases the crosstalk level. In the same way, smudge or haze on the top of the cover glass degrade the target vs crosstalk signal ratio.

The figure below shows an example of ranging distance in the case of high levels of crosstalk. The ranging distance is reported vs the real target distance. This means that the dashed line represents the ideal curve where the ranging error is zero. The higher the crosstalk signal, the greater the range linearity is affected at short distance.

Figure 12. Range vs target distance for high level of crosstalk

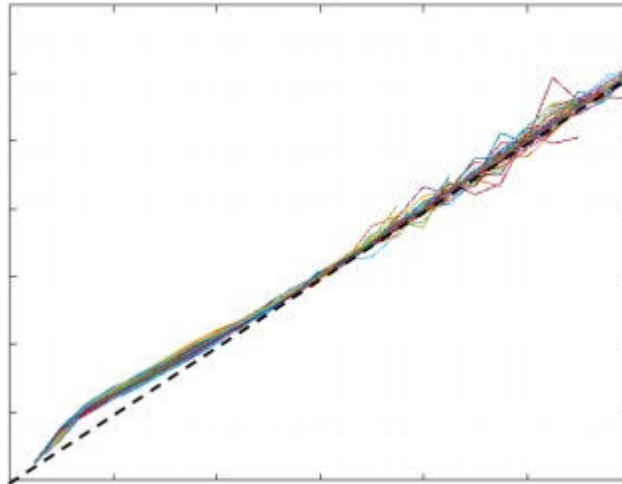

The next figure shows an example of ranging distance in the case of low levels of crosstalk signal. It shows that the crosstalk compensation has less effect on the linearity of the ranging signal in the short distances. The range error falls to zero when the target distance is bigger than the crosstalk immunity distance, which is currently ~600 mm for the VL53L8 module.

Figure 13. Range vs target distance for low level of crosstalk

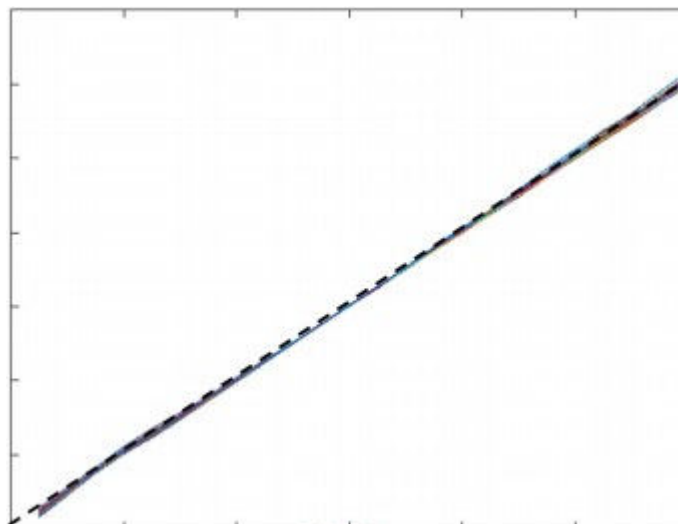

6.1 Gaskets

Gaskets reduce the crosstalk between the true signal and spurious reflections from the transmitted signal. The ideal gasket should be thick enough to fill the full air gap between the device and the cover glass. The gasket should contain two apertures large enough to allow the full Tx or Rx cone to pass through unimpeded, while also forming a light barrier between the Rx and Tx channels. The gasket should cover the maximum area between the Rx and Tx channels possible, without impeding the keepout zones.

7 Conclusion and summary table

Air gap size and cover glass properties influence the level of crosstalk signals.

Experimental results show that < 0.5 mm air gap is recommended. If a larger air gap is used, then a gasket may be required to reduce crosstalk.

Cover glass recommendation details are reported in the summary table below.

Table 5. Cover glass guidelines and summary table

Values in this table are for the final cover glass including any coatings applied.

Parameter type	Parameter details	Recommended spec for maximum performances
Optical parameter	Max crosstalk signal level accepted	300 kcps/SPAD (max)
	Transmittance at 940 nm	>87%
	Transmittance haze (visible)	< 2%
	Transmittance haze (IR)	< 1%
Mechanical parameter	Air gap ⁽¹⁾ Without gasket	< 0.5 mm
	Air gap + cover glass thickness	<1.5 mm
	Cover glass tilt	±5° ⁽²⁾
	Number of cover glass apertures	Two circular holes are preferable to protect the light trap

1. Increased air gap potentially adds crosstalk. The crosstalk may be limited with the use of a gasket. Air gaps <0.4 mm keep crosstalk below the recommended limits. Air gaps >0.7 mm require a gasket to remain within the 300 kcps/SPAD crosstalk limit.

2. Assembly tolerance is ±2°.

Note: For a particular turnkey cover glass made by third party, contact your ST sales office.

Revision history

Table 6. Document revision history

Date	Version	Changes
26-May-2023	1	Initial release
17-Oct-2023	2	Modified references to kcps to kcps/SPAD.

Contents

1	Acronyms and abbreviations	2
2	General information	3
2.1	System crosstalk	3
3	Crosstalk immunity of the VL53L8 sensors	6
4	Cover glass design	7
4.1	Optical transmission	7
4.2	Cover glass coating	8
4.3	Haze	8
4.4	Cover glass tilt and surface parallelism	8
4.5	Cover glass materials	8
5	Cover glass mechanical guidelines	9
6	Crosstalk compensation	14
6.1	Gaskets	15
7	Conclusion and summary table	16
	Revision history	17

IMPORTANT NOTICE – READ CAREFULLY

STMicroelectronics NV and its subsidiaries (“ST”) reserve the right to make changes, corrections, enhancements, modifications, and improvements to ST products and/or to this document at any time without notice. Purchasers should obtain the latest relevant information on ST products before placing orders. ST products are sold pursuant to ST’s terms and conditions of sale in place at the time of order acknowledgment.

Purchasers are solely responsible for the choice, selection, and use of ST products and ST assumes no liability for application assistance or the design of purchasers’ products.

No license, express or implied, to any intellectual property right is granted by ST herein.

Resale of ST products with provisions different from the information set forth herein shall void any warranty granted by ST for such product.

ST and the ST logo are trademarks of ST. For additional information about ST trademarks, refer to www.st.com/trademarks. All other product or service names are the property of their respective owners.

Information in this document supersedes and replaces information previously supplied in any prior versions of this document.

© 2023 STMicroelectronics – All rights reserved