



TRIAC CONTROL BY PULSE TRANSFORMER

INTRODUCTION

Among the many ways to drive a triac the pulse transformer is one of the easiest. By applying some simple rules it can be used to design an efficient triac triggering circuit without reduction of the commutation capability of the triac.

WHY USE A PULSE TRANSFORMER?

The use of pulse transformers in triac triggering circuits offers many advantages:

- Galvanic insulation between the power and gate drive circuit (a few kV).
- Gate drive circuit with a few components.
- Choice of the gate current polarity (triggering in the 2nd and 3rd quadrants for SNUBBERLESS triacs).
- Optimization of gate signal (single pulse or train of pulses).
- Possibility to drive several triacs with only one drive circuit

THE PULSE TRANSFORMER

To optimize the triac and the pulse transformer in the application it is necessary to know the main characteristics of the transformer:

The transformer ratio

It is the N_2/N_1 ratio, where N_1 corresponds to the primary winding and N_2 to the secondary.

The L_p inductance

The primary winding inductance measured at a given frequency.

The R_p resistance

The primary winding resistance.

The area of the output pulse

For a given magnetic material the voltage.time product $V_o.t_o$ of the output pulse is constant. For each type of transformer the manufacturer gives the maximum voltage.time product under no load operation which corresponds to the Figure 1.

Figure 1. Voltage across the secondary winding for a rectangular pulse across the primary

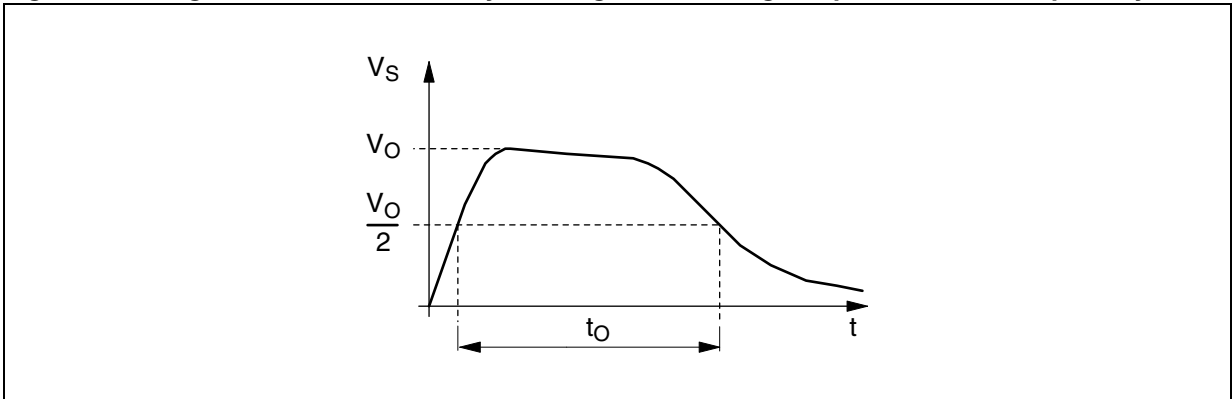

The rise time t_r

This parameter t_r defines the rise time of the output pulse as shown in Figure 2.

Figure 2. Specification of the rise time at the output of the transformer

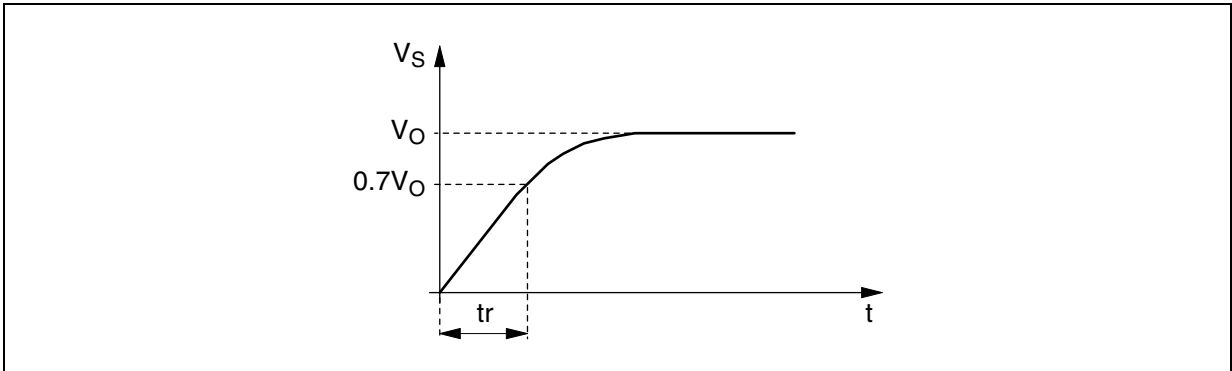
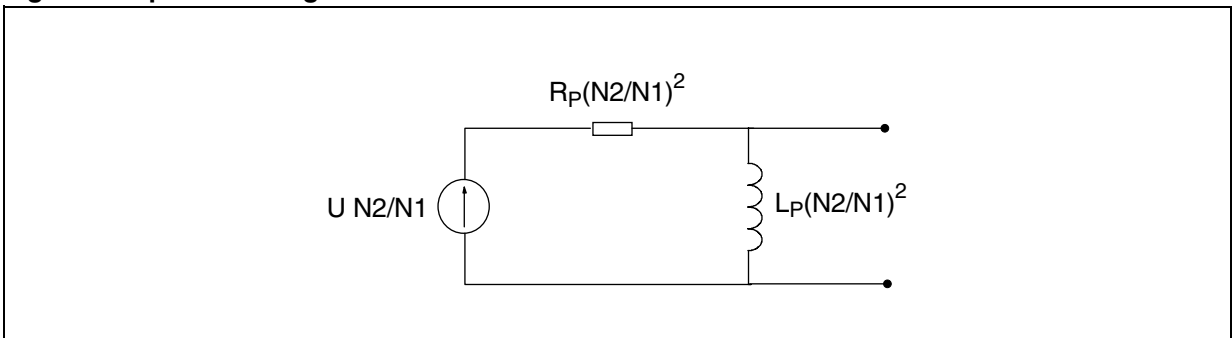

Figure 3 shows the diagram of the secondary of the transformer.

Figure 3. Equivalent diagram of the transformer



GATE PULSE

Peak value

The transformer ratio and the power supply of the primary winding define the secondary voltage. With the equivalent diagram and triac gate characteristics it is possible to determine the output current. This has to

be higher than the specified gate triggering current (I_{GT}). To have an efficient triggering it is suitable to use a safety coefficient of 2:

$$I_G > 2 I_{GT}$$

Duration

The $V_o.t_o$ product defines the maximum pulse duration at the output of the transformer. The anode current has to be higher than the specified latching current (I_L) at the end of the gate pulse.

For drives with a pulse train we can sometimes use very short pulses (for example $t_p = 10\mu s$ with a $15\mu s$ cycle).

For proper triac triggering the gate current rise time is very important in a circuit with very high di/dt ($>20 A/\mu s$): case of resistive load.

THE COMMUTATION

The use of a triac with a pulse transformer needs some precautions in order not to decrease the commutation capability.

The commutation

Review: during the conduction a certain quantity of charges is injected into the triac.

During the fall of the current most of them disappear by recombination. If the current decreases too fast the charges do not have time to recombine and some charge stays in the gate area. This can provoke a spurious firing.

The parameter which characterizes the commutation is the anode current slope $(di/dt)_c$, that is to say the slope of current before zero crossing.

The specified value in the data sheet is the critical $(di/dt)_c$. Above this value the triac is liable to fire spuriously. Figure 5 shows the spurious firing due to $(di/dt)_c$.

Case of a triac triggered by a transformer

When the triac is on, a voltage of about 0.6V appears across the gate and cathode. This voltage is either positive or negative depending on the anode current polarity. A current i can flow through the secondary winding of the transformer (see Figure 4).

Figure 4. Use of a triac with a pulse transformer: when the Triac is on a current flows through the gate

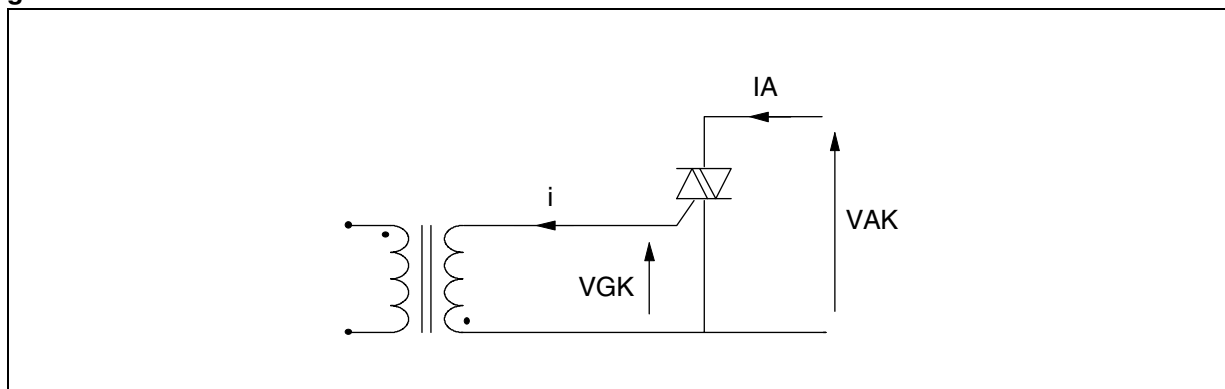

Due to the inductance of the transformer, at the end of the half wave the current i continues to flow in the gate and increases the risk of spurious firing at the next cycle (see Figure 5).

AN436 APPLICATION NOTE

Figure 5. spurious firing of the triac

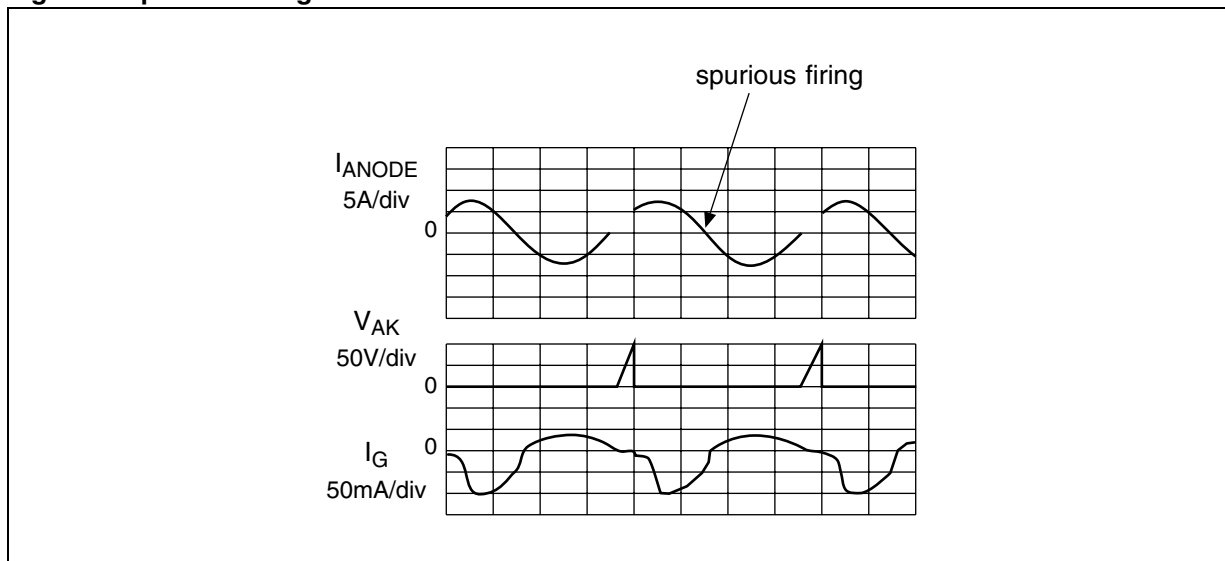

The influence of the transformer can be estimated by measuring the critical $(di/dt)_c$ of the triac with and without the transformer.

Example: BTA06-400CW

The specified $(di/dt)_c$ of this triac is:

$$3.5A/ms \text{ min at } T_j = 125^\circ C$$

Measurement of a sample without transformer:

$$(di/dt)_c = 6A/ms$$

Measurement with transformer:

$$(di/dt)_c = 3A/ms \rightarrow \text{on this sample the commutation capability is divided by 2!}$$

It is necessary to consider this phenomena and to take some safety margin (in some cases the critical $(di/dt)_c$ of the triac + transformer can be lower than the specified $(di/dt)_c$ of the triac as shown in the previous example). This is very important in the case of transient currents higher than the nominal value, as is the case with the cold filament of incandescent lamp, load dispersion, etc...

One has to take into account the maximum $(di/dt)_c$ in the application in all cases, especially in the transient state where $(di/dt)_c$ can be higher than it is in the steady state. The following example shows values for an incandescent lamp and universal motor.

Table 1. Maximum $(di/dt)_c$ in the application

	INCANDESCENT LAMP	UNIVERSAL MOTOR
NOMINAL CURRENT I_{RMS}	1.35A	3.8A
STEADY STATE $(di/dt)_c$	0.6A/ms	1.7A/ms
TRANSIENT STATE $(di/dt)_c$	2.6A/ms	5A/ms

THE SOLUTION

To avoid the reinjected current through the transformer it is necessary to connect a diode in series with the gate (see Figure 6).

Figure 6. Bearing of the commutation capability

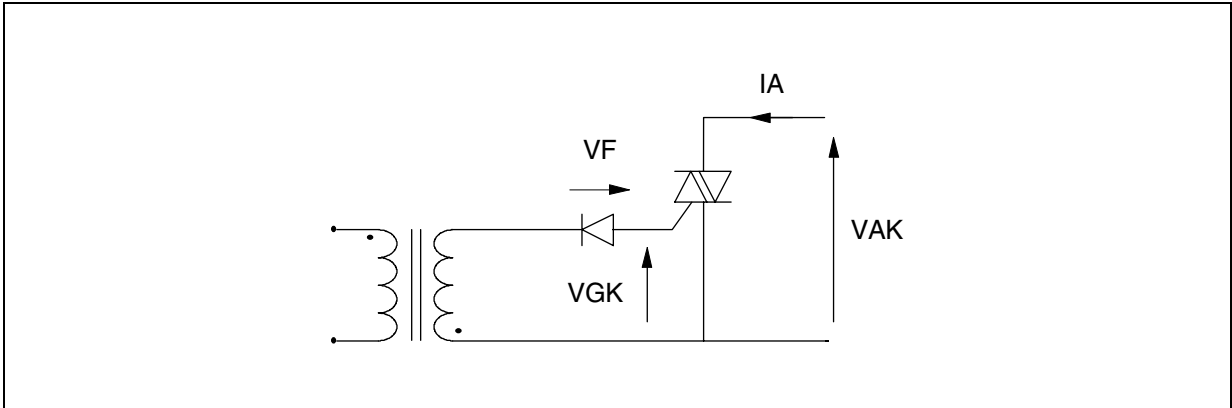

The drop voltage V_F of the diode avoid the reinjected current. The triac is triggering in the 2nd and 3rd quadrants (see Figure 7).

Figure 7. Correct running with diode

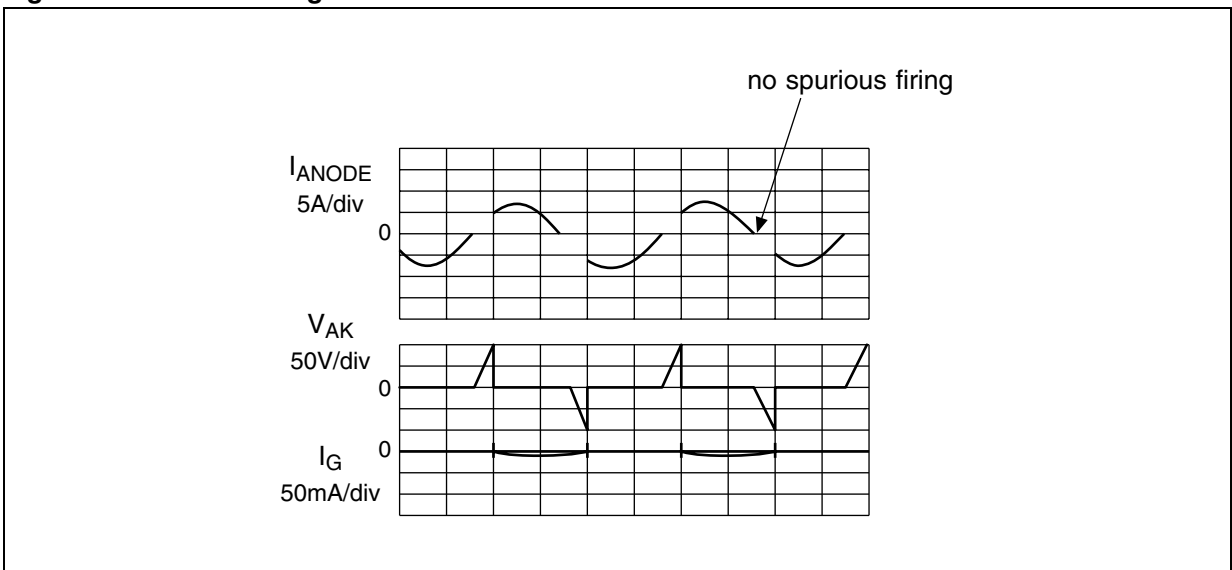

AN436 APPLICATION NOTE

TYPICAL APPLICATION EXAMPLE

Figure 8. Typical application diagram.

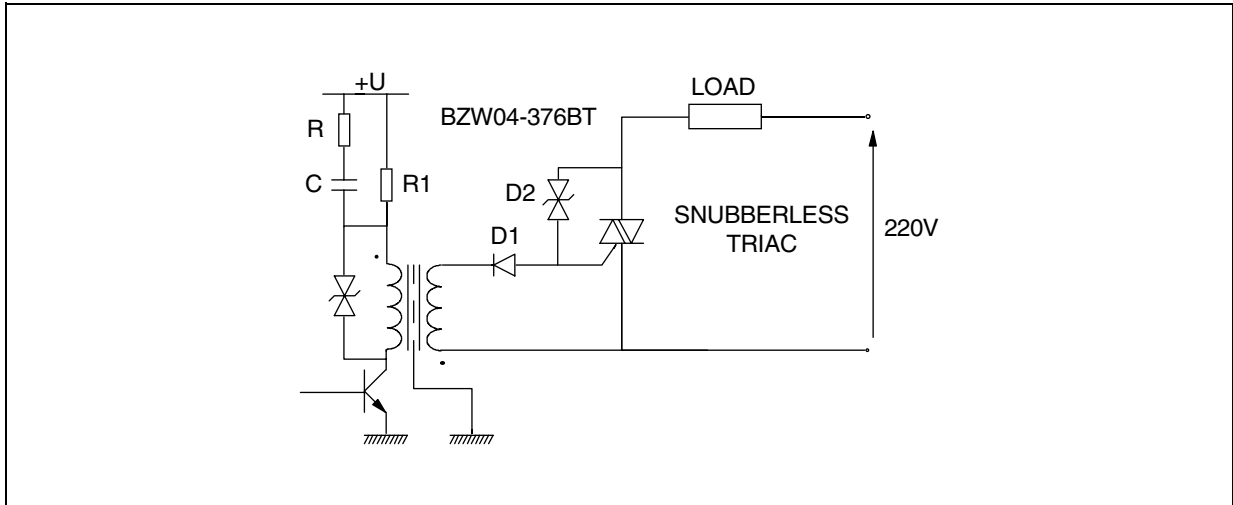

The D2 transil diode protects the triac against overvoltages (see "Protection of triacs and their control circuits" in the "Thyristors and Triacs Application manual").

The RC circuit across R1 allows an increase in the current in the transformer at the beginning of the pulse. When C is charged the resistance R1 limits the current through the transistor.

The gate current is given by the following formula (without RC).

Figure 9. Equivalent diagram

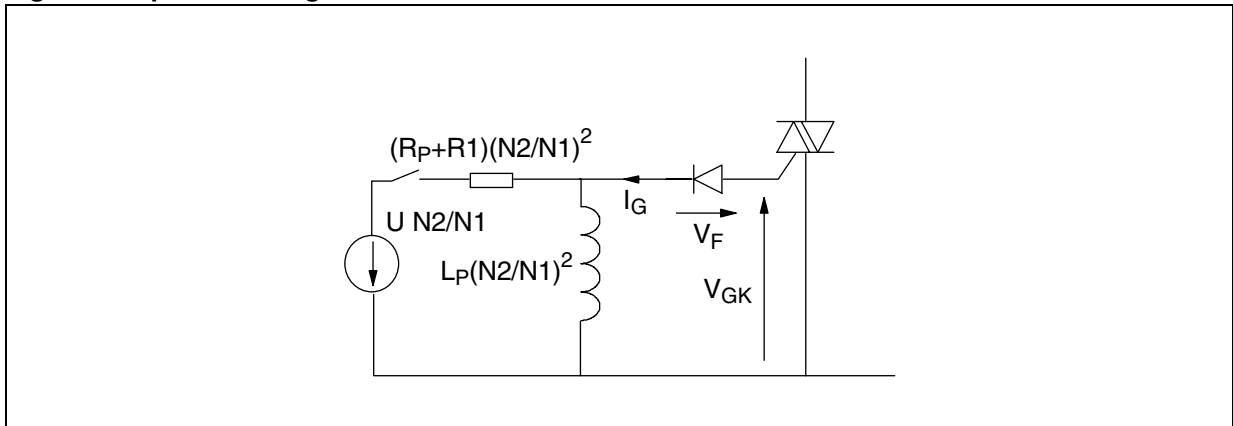

$$I_G = \frac{(V_{GK} - V_F)tp}{L_P \left(\frac{N_2}{N_1}\right)^2} + \frac{V_{GK} - V_F + U \left(\frac{N_2}{N_1}\right)^2}{(R_P + R_1) \left(\frac{N_2}{N_1}\right)^2}$$

Where: tp is the pulse duration.

Keep in mind that V_{GK} is negative because the triac is triggering in the 2nd and 3rd quadrants.

In practice the area of the pulse has to be lower than 60 or 70% of the maximum voltage.time product $V_{o.to}$.

The maximum pulse duration in the output is:

$$t_P = \frac{0.7V_{o.to}}{V_F - V_{GK}}$$

These two formulæ allow us to define the pulse transformer according to the triac sensitivity.

Example: Numerical application with a transformer having the following characteristics:

$$N_2/N_1 = 1$$

$$R_P = 0.6\Omega$$

$$L_P = 2.5mH$$

$$V_{o.to} = 250V\mu s$$

Triac: BTA08-700CW

$$I_{GT} = 35mA; V_{GK} = -2V \text{ at } I_G = 2I_{GT} \text{ (quadrants II and III)}$$

diode: $V_F = 0.7V$

Power supply:

$$U = 12V; R_1 = 100\Omega; t_p \text{ max} = 65\mu s; I_G = 70mA; t = 21\mu s$$

We have measured:

$$I_G = 85 \text{ mA at } t = 21\mu s$$

CONCLUSION

The pulse transformer provides an excellent method to trigger a triac when galvanic insulation is required. This system is appropriate to microprocessor systems.

Nevertheless it needs some precautions to avoid a decrease of the triac commutation behavior.

This precaution is achieved by adding a diode in series with the gate.

AN436 APPLICATION NOTE

REVISION HISTORY

Table 2. Revision History

Date	Revision	Description of Changes
May-1992	1	First Issue
23-Apr-2004	2	Stylesheet update. No content change.

Information furnished is believed to be accurate and reliable. However, STMicroelectronics assumes no responsibility for the consequences of use of such information nor for any infringement of patents or other rights of third parties which may result from its use. No license is granted by implication or otherwise under any patent or patent rights of STMicroelectronics. Specifications mentioned in this publication are subject to change without notice. This publication supersedes and replaces all information previously supplied. STMicroelectronics products are not authorized for use as critical components in life support devices or systems without express written approval of STMicroelectronics.

The ST logo is a registered trademark of STMicroelectronics.
All other names are the property of their respective owners

© 2004 STMicroelectronics - All rights reserved

STMicroelectronics GROUP OF COMPANIES

Australia - Belgium - Brazil - Canada - China - Czech Republic - Finland - France - Germany - Hong Kong - India - Israel - Italy - Japan -
Malaysia - Malta - Morocco - Singapore - Spain - Sweden - Switzerland - United Kingdom - United States

www.st.com