

DIMMING OF SUPER HIGH BRIGHTNESS LEDs WITH L6902D

1 Introduction

Thanks to the high efficiency and reliability, super high brightness LEDs are becoming more and more important when compared to conventional light sources. Although LEDs can be supplied directly from a simple voltage source (like battery with resistor), for most applications it is better to use a switching current source to get not even higher efficiency but also to get a better light output. This paper will focus on a L6902D based DC/DC converter with dimming interface. For more details about other converters and applications for LEDs available from STMicroelectronics please refer to other application notes ([1] and [2]).

2 Dimming Concepts

There are two basic principles how the light output of the LED can be controlled. Since the light brightness is proportional to the current, both methods are dealing with current regulation. The first and the easiest way is to control the LED current itself, with the principal sketch in Figure 1, where current is changed proportionally with the dimming signal. Disadvantage of this analog control is that there can be a significant change of color (wavelength difference could be several nanometers) in deep dimming (less than 10%). This potential disadvantage is compensated by a very simple control circuit (usually a simple potentiometer is enough).

Figure 1. Analog current control

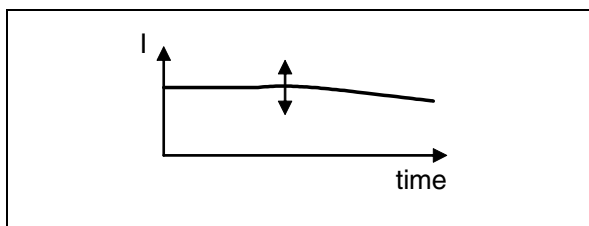
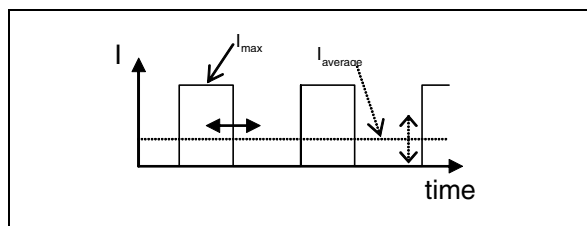

Figure 2. Average current control by PWM



The second method is based on an average current control (digital control) as can be seen in Figure 2. The current is switched between zero and the nominal current with a frequency higher than 100Hz (to avoid flickering). The change of duty cycle and hence the average current change will be seen as a brightness change, because human eye reaction is slow enough to "integrate" the light output and it will not be noticed as a blinking.

This method avoids the color change problem, but on the other hand it needs more sophisticated control circuits (usually a microcontroller or another simple PWM generator).

3 L6902D DC/DC Converter

The L6902D is a complete and simple step down switching regulator with adjustable current and voltage feedback. Thanks to its current control loop with external sense resistor it is able to work in a constant current mode, providing up to 1A output current with an accuracy of 5%. Among other features there can be also found general purpose 3.3Volts precise (2%) reference voltage or 2.5A (typical value) internal current limit for short circuit protection.

In Figure 3 is the internal structure of the L6902D converter, the datasheet [3] should be referred for more details.

Figure 3. L6902D Block diagram (see [3] for details)

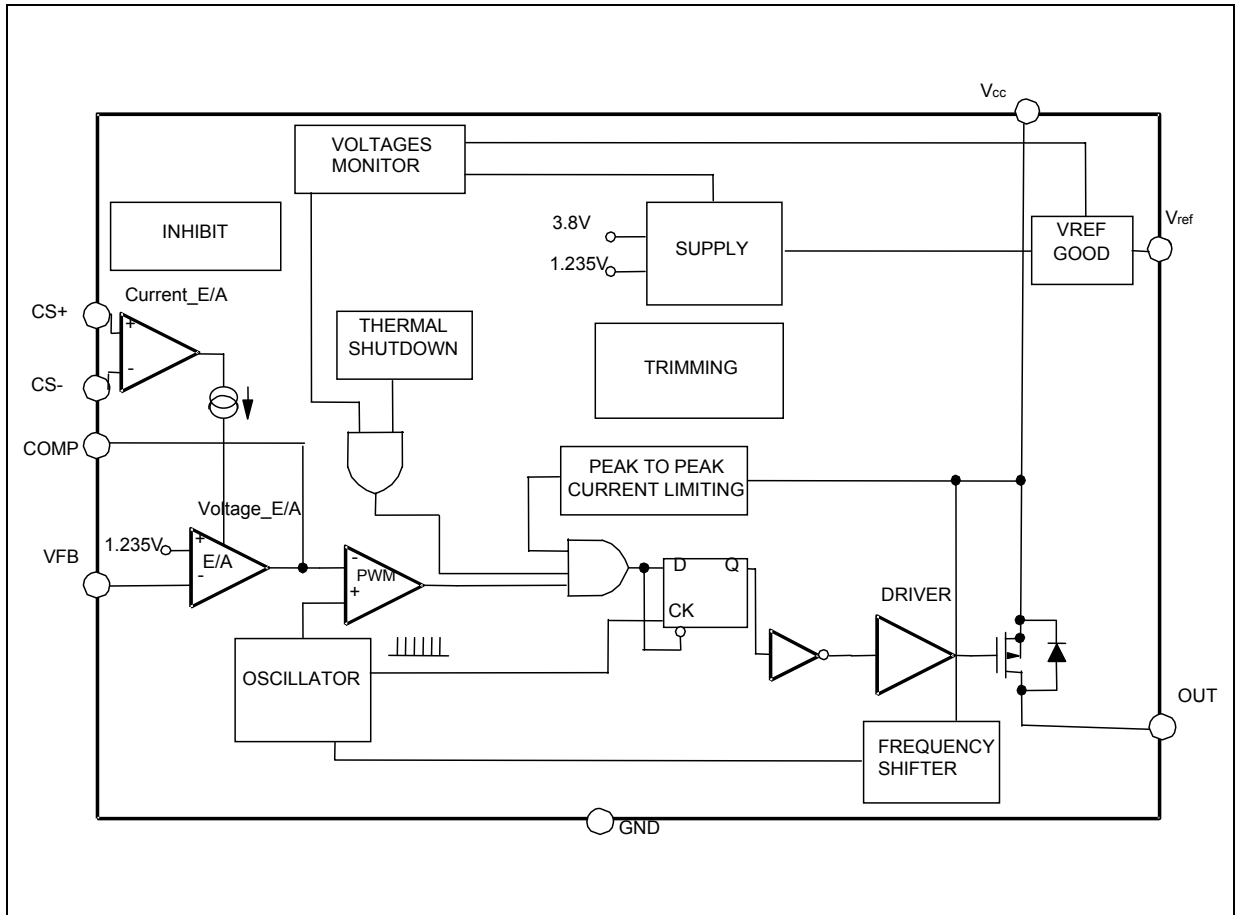

4 Application Board

An application board using the dimming principles described above has been designed and its schematic is in Figure 5. There is only a single dimming input connector on the board; usable for both dimming methods (either analog or PWM control can be used, as preferred). There were made some changes compared to the application circuit presented in datasheet [3] allowing this dimming. First of all, the sense resistor has been moved from higher voltage path (coil output) to the lower one (output ground). Then three resistors were added (R4, R5 and R6) for modifying the current sense feedback.

A signal between 0 and 3.3V should be used for analog (peak current) dimming. When the dimming pin is grounded (0V) the maximum output current is provided (350mA) and vice versa when 3.3V is applied to the pin, the current provided is zero and so the LED is off. There are two more pins on the board: 3.3V reference voltage pin and ground pin (a jumper can be used to connect the dimming pin to the ground pin for the maximum output). For the easiest way of dimming just connect the 10kΩ potentiometer between 3.3V and ground pins. The potentiometer slider should be connected to the dimming pin (as it can be seen in Figure 4).

Figure 4. Connecting the potentiometer for analog dimming

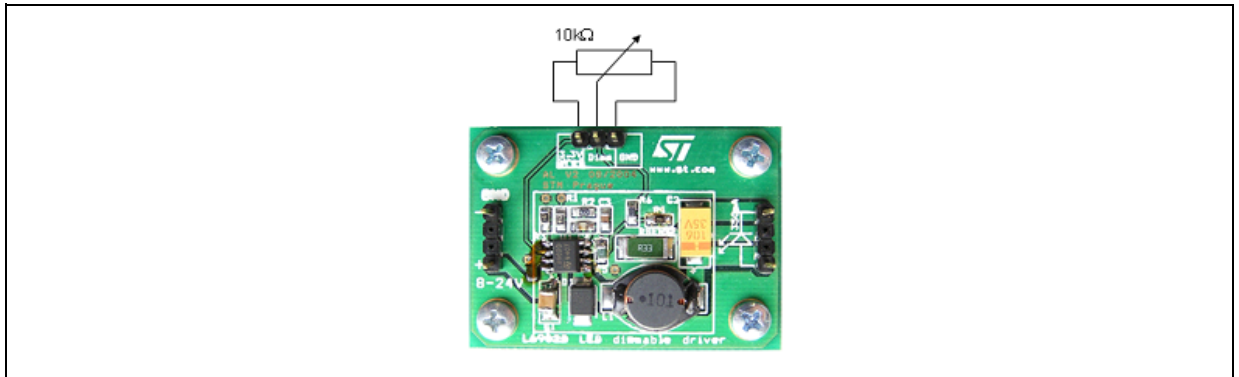

The second dimming method implemented on this board is a PWM control of average LED current. This control needs a digital PWM signal (amplitude can be either 3.3V or 5V) between dimming pin and ground pin. Then varying the duty cycle will change the LED brightness (100% means LED off and 0% means LED fully on).

With the closer look on the application (Figure 5) it is noticeable that cathode of the LED must not be connected to the ground of the circuit, because there is a sense resistor between cathode and the ground. If by any accident, LED cathode is grounded, the current feedback loop will be inactivated and the L6902D will set the maximum output voltage (as set by the voltage divider R1 and R3) regardless the current which can eventually destroy the LED. Also care must be taken on input voltage polarity together with output LED polarity. If the input polarity is twisted, the whole IC could be damaged. While with the output polarity reversed, the board itself cannot be damaged, but the LED will see the maximum voltage (as limited by the voltage divider R1 and R3) in reverse direction.

Figure 5. Board schematic (order code STLEDDDIM-EVAL1)

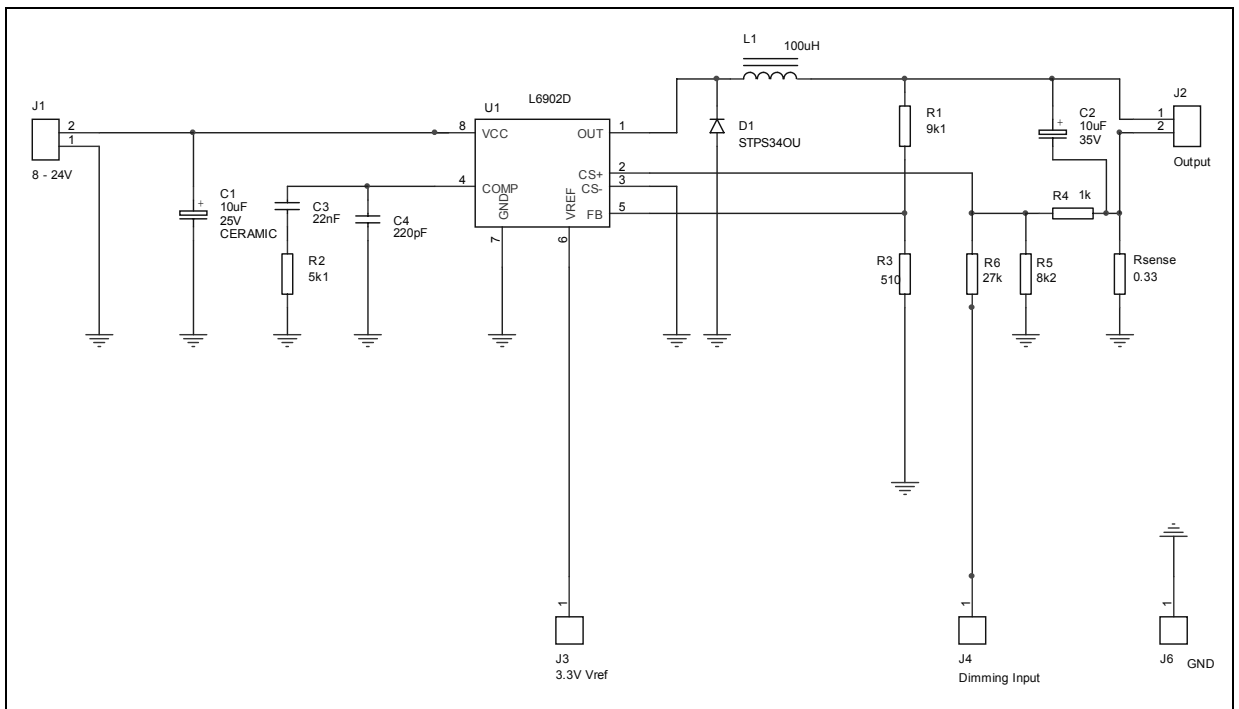

Figure 6. PCB layout

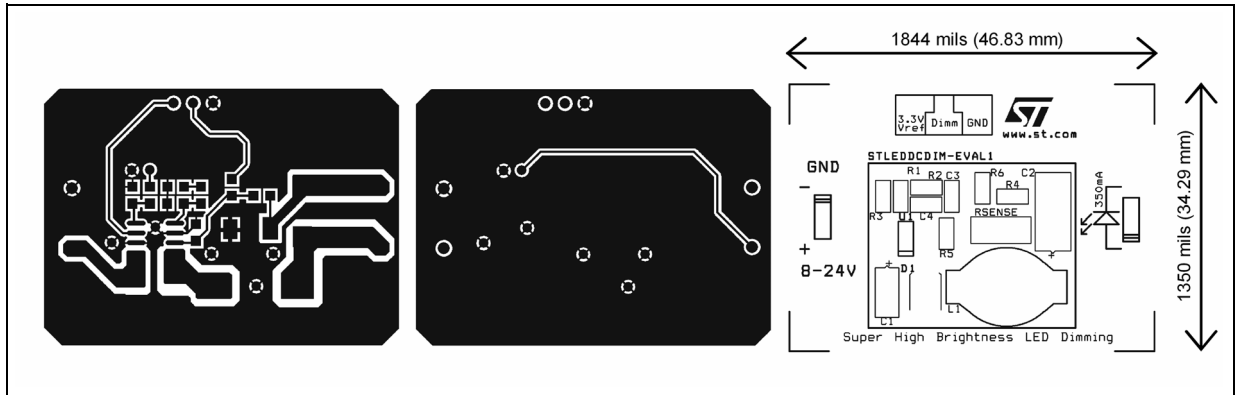

Table 1. Bill of materials

Type	Reference	Part	Supplier Order Code
Ceramic Capacitor	C1	10uF	N/A
Tantal Capacitor	C2	10µF; 35V	N/A
Capacitor SMD 0805	C3	22nF	N/A
Capacitor SMD 0805	C4	220pF	N/A
Schotky Diode	D1	STPS340U	STMicroelectronics
Connector	J1	8 -24V	N/A
Connector	J2	Output	N/A
Connector	J3	3.3V Vref	N/A
Connector	J4	Dimming Input	N/A
Connector	J6	GND	N/A
Coil	L1	100µH; 1.2A; 0.33Ω	Würth Elektronik 744 562 0
Resistor SMD 2010	Rsense	0.33	N/A
Resistor SMD 0805	R1	9k1	N/A
Resistor SMD 0805	R2	5k1	N/A
Resistor SMD 0805	R3	510	N/A
Resistor SMD 0805	R4	1k	N/A
Resistor SMD 0805	R5	8k2	N/A
Resistor SMD 0805	R6	27k	N/A
Converter	U1	L6902D	STMicroelectronics

The calculation of the resistor current feedback network can look relatively complicated, but with few simplifications it becomes easy to take in. First assumption is that all the current flows only through the R_{sense} (i.e. neglecting voltage drop on the resistors R4, R5 and R6); the value of R_{sense} is defined by the output current and the threshold voltage on CS+ pin (100mV). Unfortunately this calculation will give uncommon values (e.g. for 350mA it gives 0.2857Ω) thus the nearest higher standard (e.g. E24 series) value for R_{sense} should be selected (e.g. 0.33Ω) and then the difference between ideal and standard value is compensated by R4, R5 and R6 to receive precise output current.

The application is shifting between two limit states with dimming; maximum current (zero dimming voltage) and zero current (full dimming voltage). In Figure 7, the dimming network with grounded dimming input (Equation 1 describes the circuit) is shown, it means when the current flowing through the LED is on its maximum (i.e. 350mA on this board).

Figure 7. Dimming network with zero dimming voltage (maximum current)

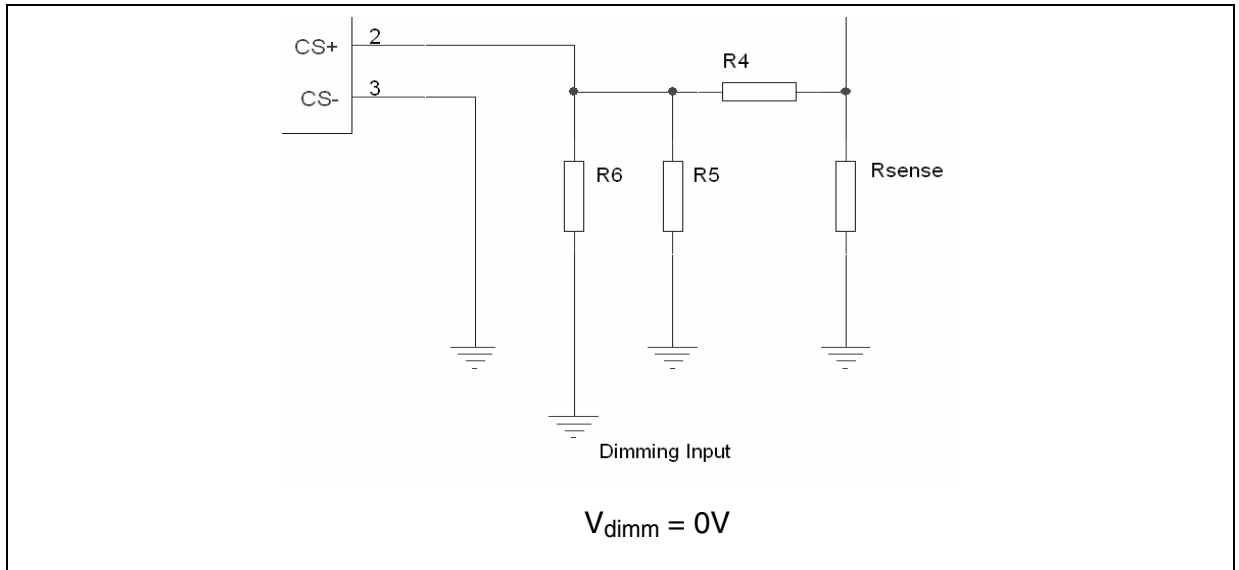

$$100mV = \frac{R5 \cdot R6 \cdot I_{LED} \cdot R_{sense}}{R4 \cdot R5 + R4 \cdot R6 + R5 \cdot R6} \quad \text{Eq 1}$$

The second limit state is depicted in Figure 8. In this case the current through the Rsense is zero (LED is off) and thus on point A there is a zero voltage (i.e. ground). The Equation 2 shows the calculation for this state.

Figure 8. Dimming network with maximum dimming voltage (zero output current)

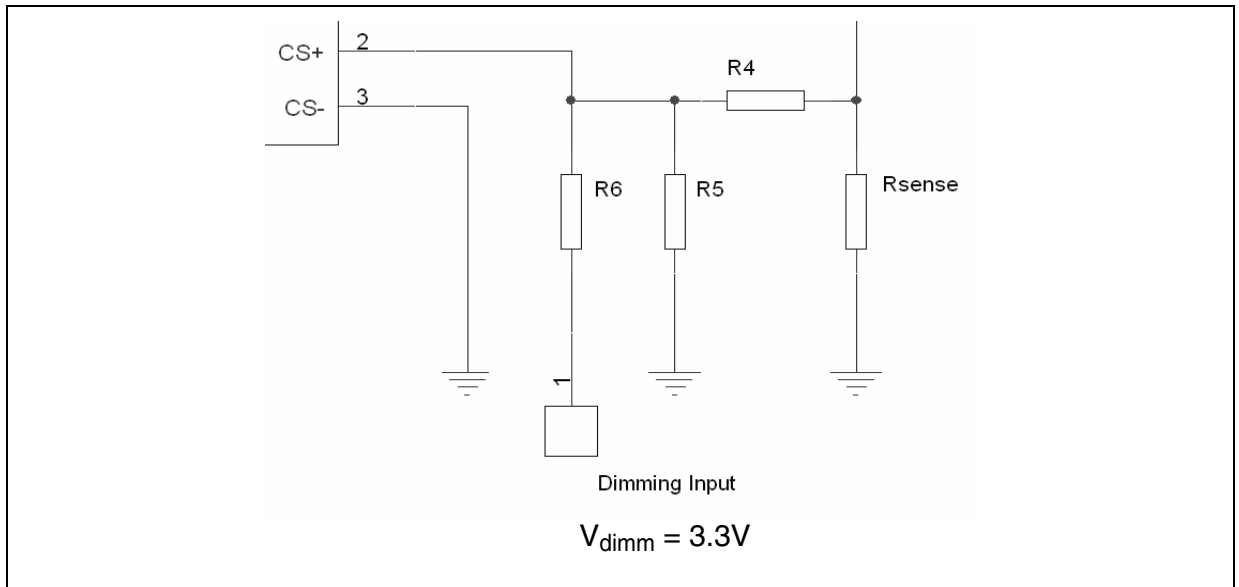

$$100mV = V_{dimMAX} \frac{R4 \cdot R5}{R4 \cdot R5 + R4 \cdot R6 + R5 \cdot R6} \quad \text{Eq 2}$$

Both equations (Equation 1 and Equation 2) must be valid together, i.e. two equations for three variables (I_{LED} , R_{sense} and V_{dimMAX} should be selected before). One resistor must be chosen before and than the other resistors calculated from the equations mentioned. This process should be iterative (calculated for different chosen resistors) to get resistor values as close to the industrial standard values as possible. The Table 2 can help for work simplification, because it contains resistor values for the most common super high brightness LEDs.

Table 2. Pre-calculated standard values for feedback loop

I_{LED} [mA]*	V_{dimMAX} [V]**	R_{sense} [mΩ]	$R4$ [Ω]	$R5$ [Ω]	$R6$ [Ω]
350	3.3	330	1000	8200	27000
700	3.3	200	910	2400	20000
1000	3.3	120	910	5600	24000

* I_{LED} is a nominal LED current obtained with minimum dimming voltage ($V_{dim}=0V$)
 ** V_{dimMAX} means dimming voltage for maximum dimming i.e. zero output current ($I_{LED}=0A$)

5 Measurement

A couple of measurements have been performed on the board; the results are on the graphs below. One up to six LEDs in serial string have been used as load (Golden Dragon LW W5SG from OSRAM)

In Figure 9 there is a LED current waveform during dimming with PWM signal at 100Hz frequency. It could be noticed a waveform rounding during turning-on and off, which is caused by charging the output capacitor C2. If the sharper on and off edges are needed a smaller capacitor should be used (e.g. 1μF), but on the other side it must be taken in account that it will rise the current ripple.

Figure 9. PWM dimming (50%)

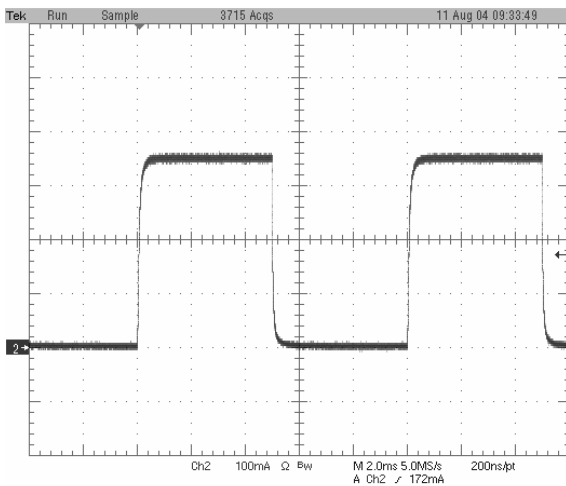
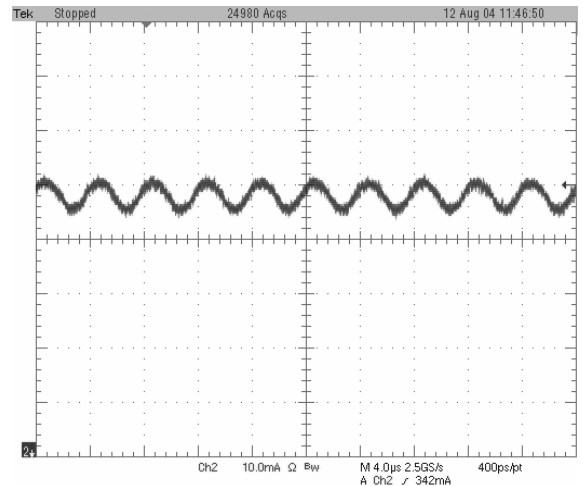

Figure 10. Current ripple (1 LED, 15V input, 0% dimming)



In Figure 10 the detail of output current is depicted, where the ripple during all the measurement stayed below $\pm 5\text{mA}$, (i.e. less than 2%). And as mentioned above, if a less wavy output is needed, bigger output capacitor should be used, but then a slower on and off edges will appear.

Efficiency of the converter is processed in Figure 11 and Figure 12, where it is showed that more difference between input and output voltage or lower load current, causes lower efficiency. For six LEDs in one serial string (voltage drop around 20Volts) and input voltage 25V the efficiency was measured above 93%.

Figure 11. Efficiency vs. input voltage (@ 350mA output current)

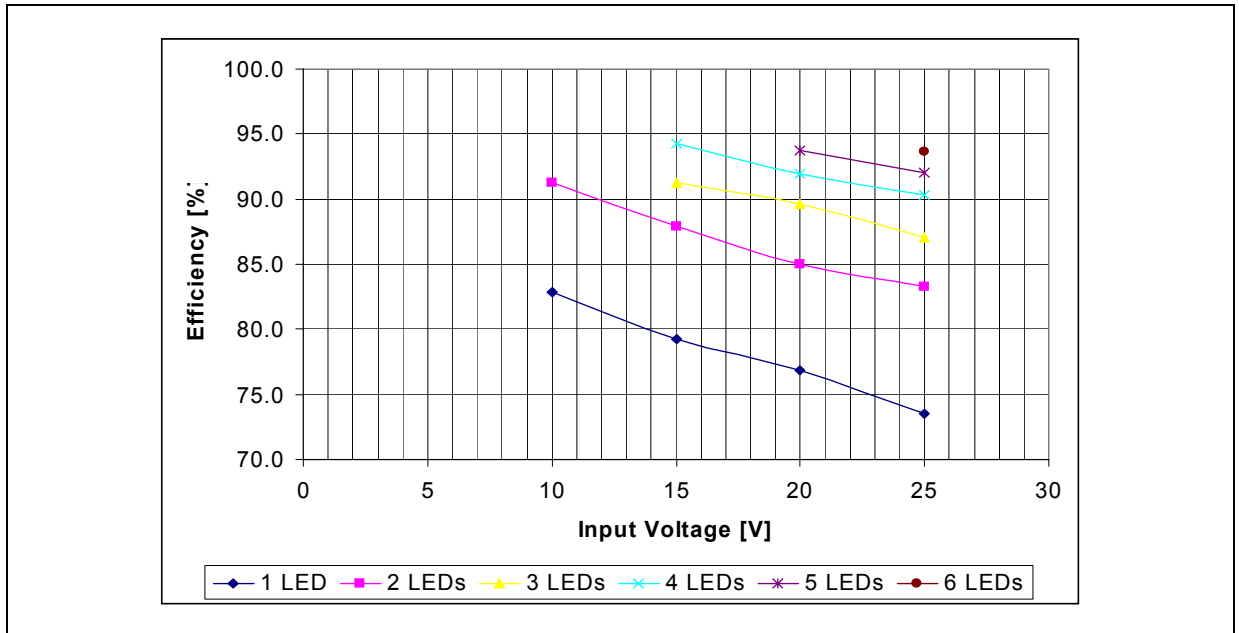

Figure 12. Efficiency vs. number of LEDs @ 25V

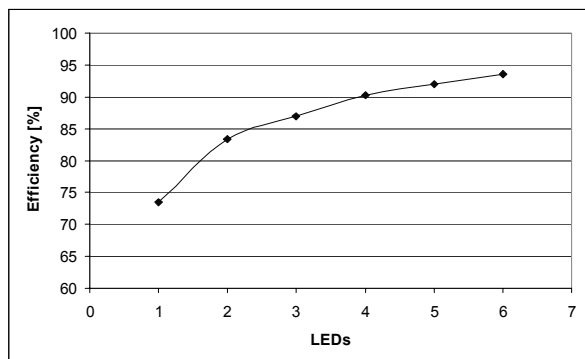
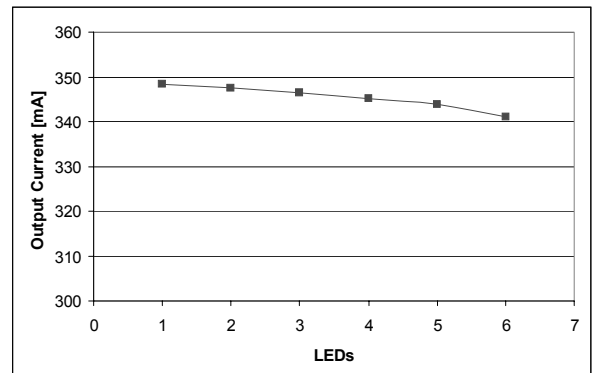

Figure 13. Output current variation



Increasing the number of LEDs in series in one string (on Figure 13) a lower output current can be observed (for six LEDs it is 341mA instead of 350mA). That means less than 3% difference, what should be still acceptable especially considering 5% precision of the current sensing amplifier in L6902D.

The average value of the output current during dimming is depicted in Figure 14 and Figure 15. Almost ideal dimming curve can be observed during digital control (Figure 15). On the analog dimming curve (Figure 14) it can be seen that current is already zero for 3.1V in place of 3.3V. This behavior is caused by the use of industrial resistances (E24 values) instead of the exact values calculated from Equation 1 and Equation 2 and it allows to have LED safely off when maximum dimming voltage is applied.

Figure 14. Output Current during analog dimming

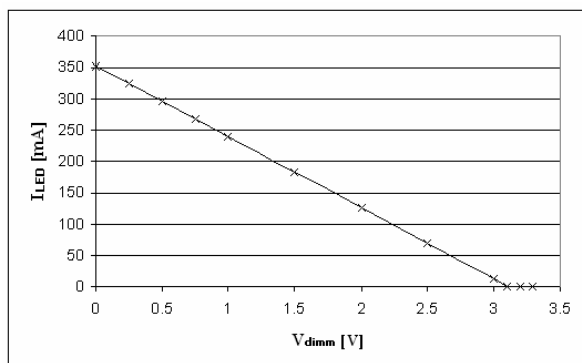
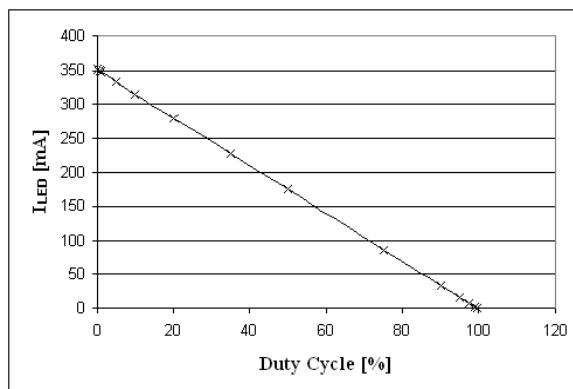

Figure 15. Output current during digital dimming



6 References and Related Materials

- [1] AN1891 - Application ideas: Driving LEDs using L497x, L597x, L692x DC-DC converters families
- [2] AN1941 - Low voltage LED driver using L6920D, L4971 and L6902D
- [3] L6902D Datasheet

7 Revision History

Table 3. Revision History

Date	Revision	Description of Changes
02-Mar-2005	1	First Issue
05-Jul-2005	2	Corrected the Eq. 2 to page 5/9

The present note which is for guidance only, aims at providing customers with information regarding their products in order for them to save time. As a result, STMicroelectronics shall not be held liable for any direct, indirect or consequential damages with respect to any claims arising from the content of such a note and/or the use made by customers of the information contained herein in connection with their products.

Information furnished is believed to be accurate and reliable. However, STMicroelectronics assumes no responsibility for the consequences of use of such information nor for any infringement of patents or other rights of third parties which may result from its use. No license is granted by implication or otherwise under any patent or patent rights of STMicroelectronics. Specifications mentioned in this publication are subject to change without notice. This publication supersedes and replaces all information previously supplied. STMicroelectronics products are not authorized for use as critical components in life support devices or systems without express written approval of STMicroelectronics.

The ST logo is a registered trademark of STMicroelectronics.
All other names are the property of their respective owners

© 2005 STMicroelectronics - All rights reserved

STMicroelectronics group of companies

Australia - Belgium - Brazil - Canada - China - Czech Republic - Finland - France - Germany - Hong Kong - India - Israel - Italy - Japan - Malaysia - Malta - Morocco - Singapore - Spain - Sweden - Switzerland - United Kingdom - United States of America

www.st.com